

## CoolSET™ SiP System in Package ICE1 Family - 100LM series

### Features

- Integrated 800 V and 950 V avalanche rugged CoolMOS™ P7
- Fast startup with integrated 950 V startup-cell
- Integrated synchronous rectification (SR) driver with typical 10 V output
- Integrated reinforced isolated communication from secondary to primary side
- Novel zero voltage switching (ZVS) flyback operation for lowest switching losses and low electromagnetic interference (EMI) signature
- Reliable pulse width modulation (PWM) switching operation by synchronized timing of primary and secondary side SR switch
- Supports primary side wide VCC operating range up to 29 V
- Optimized low supply currents for hysteretic mode operation to reach stand-by power < 30 mW
- Built-in secondary side feedback control loop with error amplifier
- Multi-mode control for optimized efficiency across the entire load range
- Auto-restart mode protection for VCC over/undervoltage, overload/open-loop, line/output overvoltage, overtemperature

### Potential applications

- Auxiliary power supply for home appliances
- Auxiliary power supply for telecom/server
- General SMPS

### Product validation

- Qualified for industrial applications according to the relevant tests of JEDEC JESD47, JESD22, and J-STD-020.
- Pending reinforced isolation certification according to IEC 60747-17 (VDE 0884-17), UL 1577, CQC (GB4943.1) to meet IEC 62368-1, IEC 61010-1, IEC 60355-1, CQC isolation requirements

### Description

The CoolSET SiP 100LM series (ICE1xxLM-Vxxx) enables effective reduction of system complexity. A high amount of discrete system components can be removed due to system forward integration. Beside the integration of the high voltage power switch and control on primary side, also the secondary side SR control and regulation loop is integrated. The timings of primary side power switch control and secondary side SR control are matched and enable reliable and robust operation under all switching conditions. The used coreless transformer technology (CT-Link) provides reinforced and safe isolated communication between primary and secondary side. Advanced PWM switching pattern forces a quasi-resonant ZVS flyback operation, reducing the turn-on switching losses and optimizing EMI signature. An advanced set of protection features supports ease of design-in.

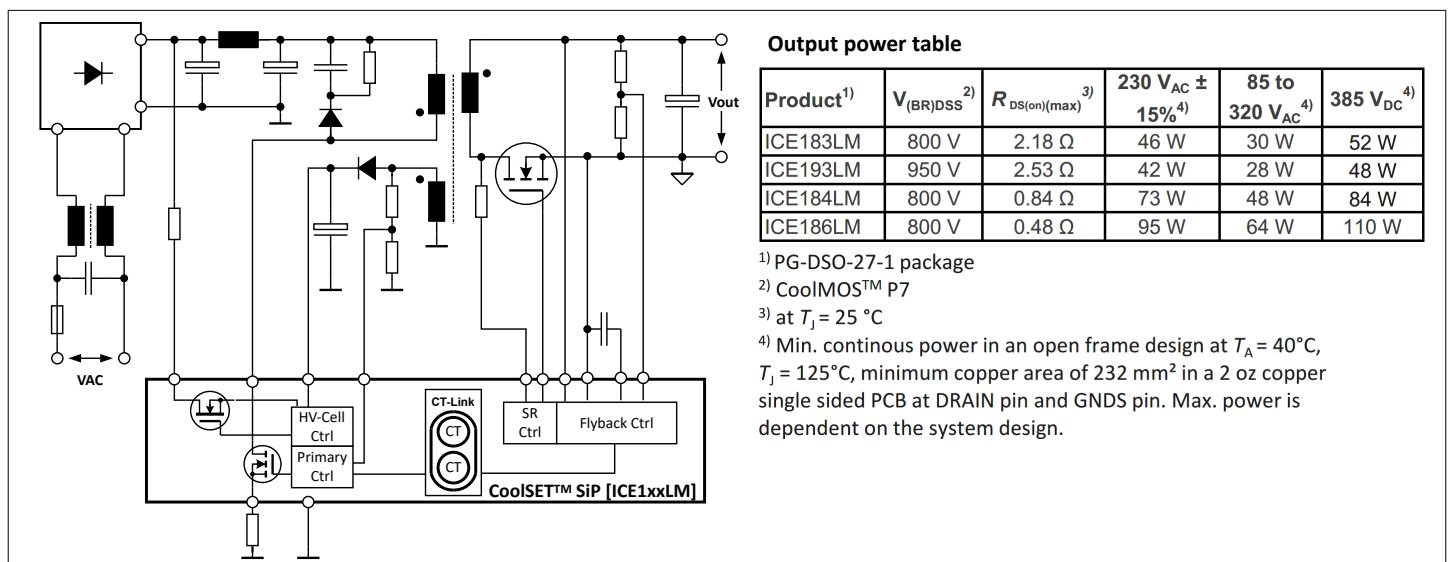

Output power table

Product <sup>1)</sup>	$V_{(BR)DSS}$ <sup>2)</sup>	$R_{DS(on)(max)}$ <sup>3)</sup>	230 V <sub>AC</sub> ± 15% <sup>4)</sup>	85 to 320 V <sub>AC</sub> <sup>4)</sup>	385 V <sub>DC</sub> <sup>4)</sup>
ICE183LM	800 V	2.18 Ω	46 W	30 W	52 W
ICE193LM	950 V	2.53 Ω	42 W	28 W	48 W
ICE184LM	800 V	0.84 Ω	73 W	48 W	84 W
ICE186LM	800 V	0.48 Ω	95 W	64 W	110 W

<sup>1)</sup> PG-DSO-27-1 package

<sup>2)</sup> CoolMOS™ P7

<sup>3)</sup> at  $T_J = 25\text{ °C}$

<sup>4)</sup> Min. continuous power in an open frame design at  $T_A = 40\text{ °C}$ ,  $T_J = 125\text{ °C}$ , minimum copper area of 232 mm<sup>2</sup> in a 2 oz copper single sided PCB at DRAIN pin and GNDS pin. Max. power is dependent on the system design.

Typical application

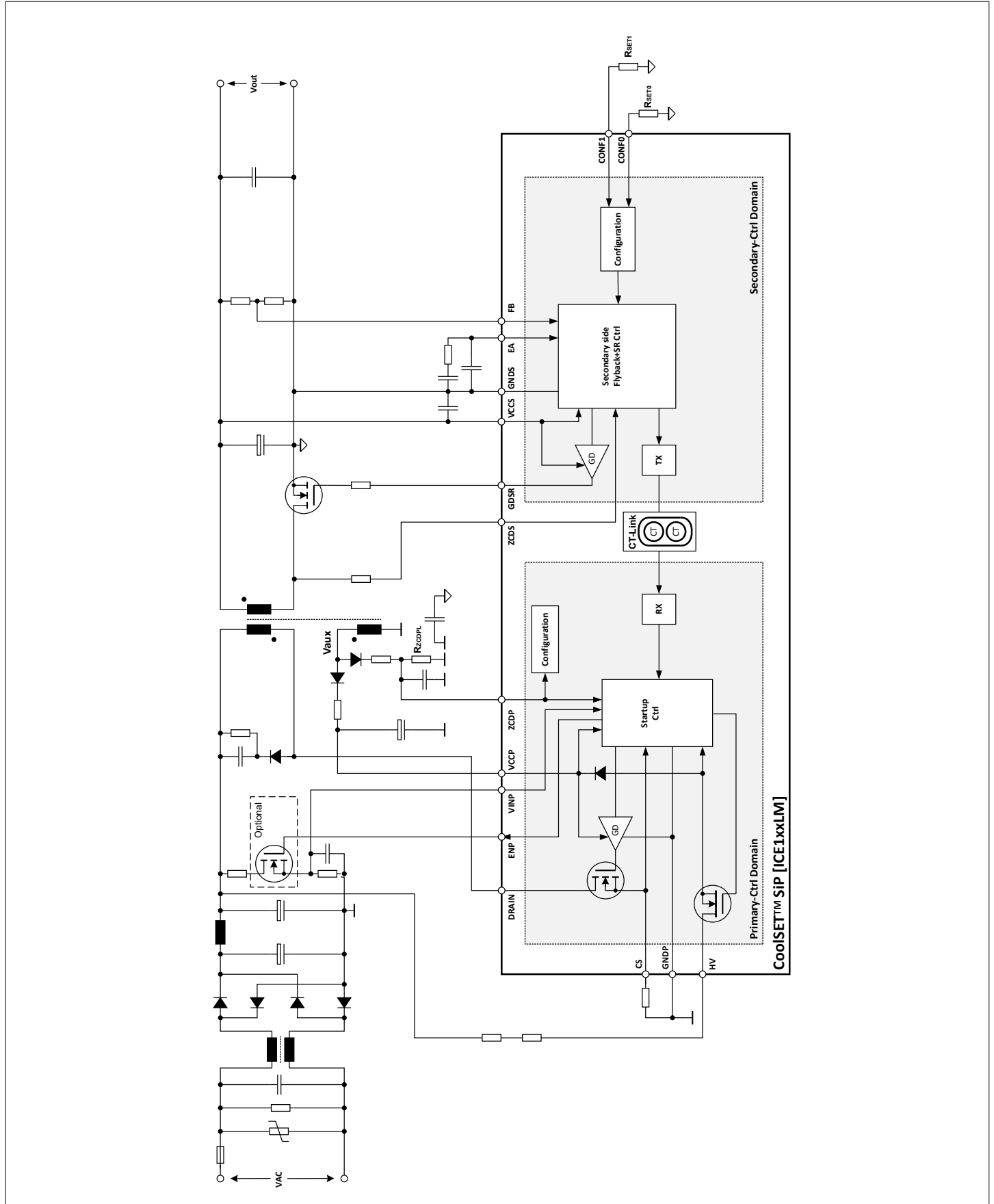

Typical application for  $V_{IN} = 400 V_{DC}$  with ICE1xxLM-V101

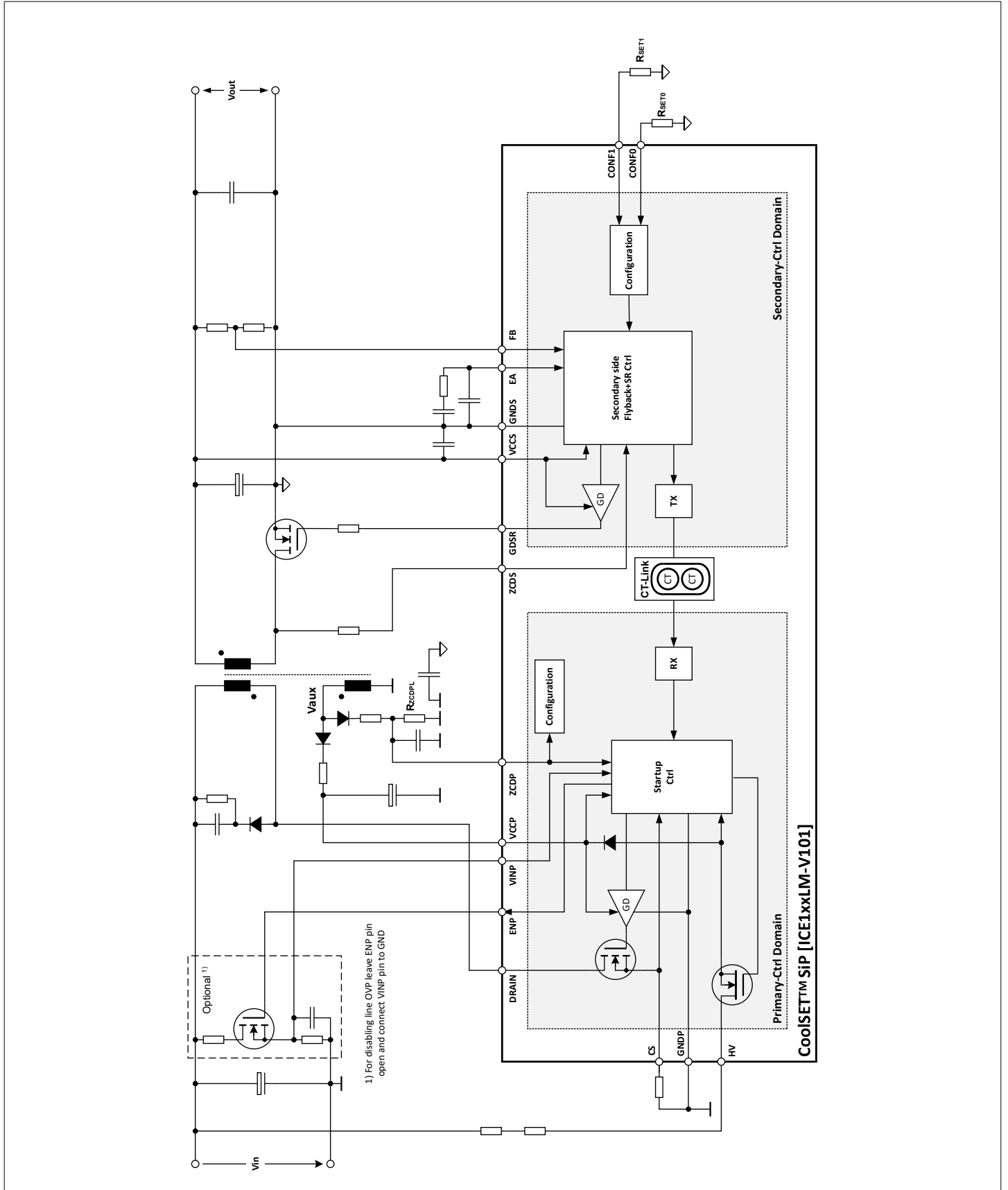

## Table of contents

	<b>Table of contents</b> .....	4
<b>1</b>	<b>Pin configuration and functionality</b> .....	6
<b>2</b>	<b>Representative block diagram</b> .....	8
<b>3</b>	<b>Functional description</b> .....	9
3.1	Introduction .....	9
3.2	Power supply management .....	9
3.2.1	Primary VCCP capacitor charge-up and startup sequence .....	9
3.2.2	Secondary VCCS startup sequence .....	9
3.3	Control features .....	9
3.3.1	High voltage sensing via HV startup-cell at HV pin .....	9
3.3.2	HV sensing via VINP pin .....	10
3.3.3	Primary current sensing at CS pin .....	10
3.3.4	Primary ZCDP sensing .....	10
3.3.5	Primary soft-start control .....	11
3.3.6	Normal operation .....	12
3.3.6.1	Secondary take-over of control .....	12
3.3.6.2	Secondary ZCDS sensing .....	12
3.3.6.3	Synchronous rectifier .....	12
3.3.6.4	Self-adapting current injection for zero voltage switching .....	12
3.3.6.5	Closed loop operation .....	13
3.3.7	Multi-mode operation .....	13
3.3.7.1	QR operation with frequency limits .....	13
3.3.7.2	Skip operation .....	14
3.3.7.3	Hysteretic mode operation .....	14
3.3.8	Enable output signal .....	17
3.4	Protection features .....	17
3.4.1	Primary side protection features .....	18
3.4.1.1	Primary VCCP overvoltage and undervoltage protection .....	18
3.4.1.2	Primary VCCP short to GND protection .....	18
3.4.1.3	Primary maximum peak current limitation (OCP1max) .....	18
3.4.1.4	Primary maximum power limitation .....	19
3.4.1.5	Primary 2nd level overcurrent (OCP2) protection .....	19
3.4.1.6	Primary CS floating protection .....	19
3.4.1.7	Primary overtemperature protection .....	19
3.4.1.8	Primary brownin and brownout protection .....	19
3.4.1.9	Primary line overvoltage protection .....	19
3.4.1.10	Primary output overvoltage protection .....	19
3.4.1.11	Primary output undervoltage protection .....	19
3.4.1.12	Primary ZCDP short to GNDP protection .....	20

3.4.1.13	Primary close-loop timeout protection .....	20
3.4.2	Secondary side protection functions .....	20
3.4.2.1	Secondary VCCS undervoltage and overvoltage protection .....	20
3.4.2.2	Secondary output overvoltage protection .....	20
3.4.2.3	Secondary open-loop protection .....	20
3.5	Hardware configuration by external resistor setting .....	20
3.5.1	Primary side configuration .....	20
3.5.2	Secondary side configuration .....	21
<b>4</b>	<b>Characteristics</b> .....	<b>23</b>
4.1	Absolute maximum ratings .....	23
4.2	Package characteristics .....	24
4.3	Operating conditions .....	25
4.4	Electrical characteristics .....	26
4.4.1	Power supply primary (VCCP pin) .....	26
4.4.2	High voltage (HV pin) .....	27
4.4.3	Current sensing primary (CS pin) .....	28
4.4.4	Primary zero-crossing detection and output voltage measurement (ZCDP pin) .....	29
4.4.5	Bus voltage sensing primary (VINP pin) .....	29
4.4.6	Primary output enable control (ENP pin) .....	30
4.4.7	Power switch .....	30
4.4.8	Power supply secondary (VCCS pin) .....	31
4.4.9	Feedback (FB pin) .....	32
4.4.10	Multi-mode and error amplifier output (EA pin) .....	32
4.4.11	Jitter function .....	34
4.4.12	Zero-crossing detection secondary (ZCDS pin) .....	34
4.4.13	SR gate driver (GDSR pin) .....	35
4.4.14	Secondary side configuration (CONF0 and CONF1 pins) .....	36
4.4.15	Primary overtemperature sensing .....	36
4.4.16	Common mode transient immunity (CMTI) .....	36
4.4.17	Isolation specifications .....	37
4.4.18	Safety supply power .....	39
<b>5</b>	<b>Package information</b> .....	<b>40</b>
5.1	Outline dimensions and footprint .....	40
5.2	Marking .....	41
5.3	Green product (RoHS compliant) .....	42
<b>6</b>	<b>Part ordering information</b> .....	<b>43</b>
<b>7</b>	<b>Revision history</b> .....	<b>44</b>
	<b>Disclaimer</b> .....	<b>45</b>

## 1 Pin configuration and functionality

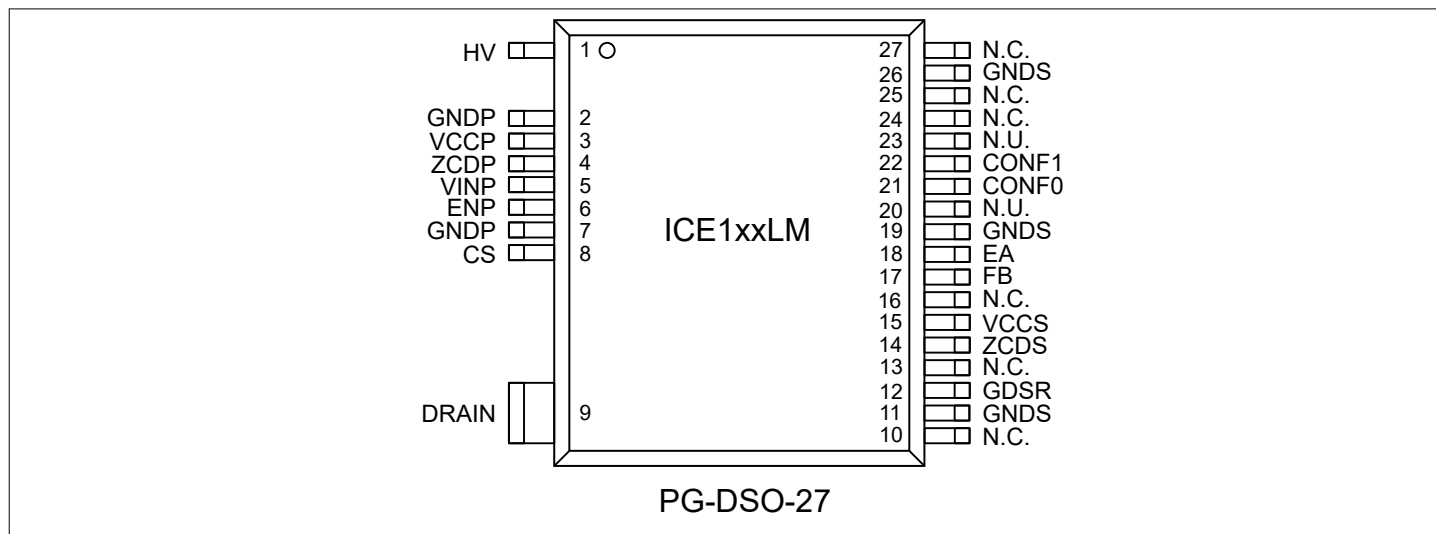

**Figure 1** Pin configuration

**Table 1** Pin functionality

Symbol	Pin	Type	Function
HV	1	I	<b>High voltage</b> HV pin is connected via a series resistor to VIN node.
GNDP	2	O	<b>Ground primary side</b> Power and signal ground.
VCCP	3	IO	<b>Voltage supply primary side</b> Primary side power supply.
ZCDP	4	I	<b>Zero-crossing detection primary side</b> ZCDP pin is connected to the auxiliary winding of the transformer via a resistor divider and diode.
VINP	5	I	<b>Input voltage sensing primary side</b> VINP pin is connected to a resistor divider for measuring the voltage at the bulk capacitor.
ENP	6	O	<b>Enable signal primary side</b> ENP pin is used to enable/disable the resistor divider at VINP pin during hysteretic stand-by operation.
GNDP	7	O	<b>Ground primary side</b> Power and signal ground.
CS	8	IO	<b>Current sensing primary side</b> CS pin is connected to a shunt resistor for measuring the primary side current ramp during turn-on phase.
DRAIN	9	I	<b>Drain</b> DRAIN of internal high voltage power switch.

(table continues...)

1 Pin configuration and functionality

**Table 1** (continued) Pin functionality

Symbol	Pin	Type	Function
N.C.	10	-	Keep open, must be not connected to ensure minimum creepage distance between primary and secondary side > 8 mm.
GNDS	11	O	<b>Ground secondary side</b> Power and signal ground.
GDSR	12	O	<b>SR gate driver</b> GDSR pin is connected to the gate of the SR power switch.
N.C.	13	-	Not connected. Connect to GNDS.
ZCDS	14	I	<b>Zero-crossing detection secondary side</b> ZCDS pin is connected to the secondary side output winding of the transformer via a resistor.
VCCS	15	I	<b>Voltage supply secondary side</b> Secondary side power supply
N.C.	16	-	Not connected. Connect to GNDS.
FB	17	I	<b>Feedback</b> FB pin is connected via resistor divider to the output voltage rail.
EA	18	IO	<b>Error amplifier</b> EA pin is connected to the external compensation network.
GNDS	19	O	<b>Ground secondary side</b> Power and signal ground.
N.U.	20	-	Not used. Connect to GNDS.
CONF0	21	I	<b>Configuration setting 0</b> CONF0 pin is connected to a resistor for setting the transformer winding ratio parameter.
CONF1	22	I	<b>Configuration setting 1</b> CONF1 pin is connected to a resistor for setting the target parameter table.
N.U.	23	-	Not used. Connect to GNDS.
N.C.	24, 25	-	Not connected. Connect to GNDS.
GNDS	26	O	<b>Ground secondary side</b> Power and signal ground.
N.C.	27	-	Keep open, must not be connected to ensure minimum creepage distance between primary and secondary side > 8 mm.

## 2 Representative block diagram

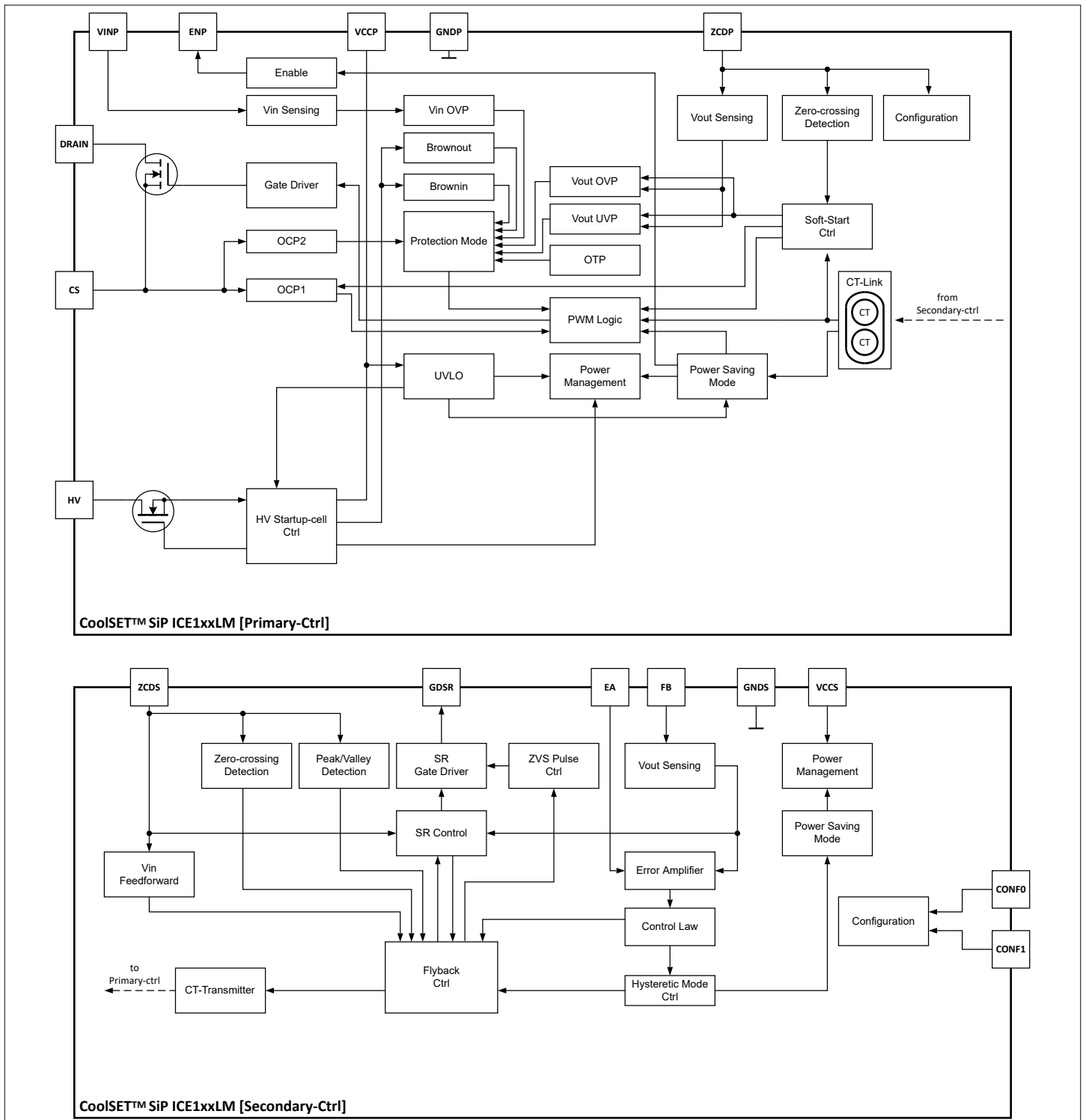

Figure 2 Block diagram CoolSET™ SiP ICE1xxLM

### 3 Functional description

The functional description gives an overview about the integrated functions and features and their relationship. The numerical values of the mentioned parameters are shown in [Chapter 4](#).

#### 3.1 Introduction

The CoolSET™-SiP ICE1 product enables significant system forward integration for a flyback topology based switching mode power supply (SMPS). In one package it integrates the primary side control, the primary side power switch, the secondary side control for feedback loop and synchronous rectification (SR). Furthermore, the HV startup-cell is providing a switchable high voltage low impedance sensing path. The communication from secondary side to primary side is performed via coreless transformer reinforced isolation barrier.

#### 3.2 Power supply management

The power supply management is separated for the primary and secondary side isolated power supply domains (VCCP, GNDP) and (VCCS, GNDS).

##### 3.2.1 Primary VCCP capacitor charge-up and startup sequence

A 950 V HV startup-cell charges up the VCCP capacitor with a two steps constant current source  $I_{VCCPcharge1}$  and  $I_{VCCPcharge2}$ . In phase I, a smaller constant current source  $I_{VCCPcharge1}$  charges the VCCP capacitor until  $V_{VCCP}$  reaches  $V_{VCCPstart}$ . After this phase, the phase II higher constant current source  $I_{VCCPcharge2}$  charges the VCCP capacitor further, until  $V_{VCCP}$  exceeds the turn on threshold  $V_{VCCPon}$ . Once  $V_{VCCP}$  has reached the  $V_{VCCPon}$  level, the primary side controller power management module is powered up and the configuration is loaded according defined hardware configuration in phase II. After phase II, the primary controller starts switching with soft-start if  $V_{IN}$  is higher than the threshold sensed with  $I_{HV\_BI}$  and lower than the threshold  $V_{VINP\_LOVP}$ , and the primary side controller die junction temperature is lower than the overtemperature threshold  $T_{JPOTP}$ .

##### 3.2.2 Secondary VCCS startup sequence

The secondary side controller is supplied by the VCCS pin. When connected to the output voltage, the supply voltage ramps up during the primary side soft-start phase. After  $V_{VCCS}$  exceeds the threshold  $V_{VCCSon}$  and additionally  $V_{FB}$  exceeds the threshold  $V_{FBstart}$ , the secondary side starts to take over the PWM control.

#### 3.3 Control features

This chapter describes the flyback control features for the primary and secondary side.

##### 3.3.1 High voltage sensing via HV startup-cell at HV pin

The controller senses the rectified input voltage through the HV pin using the integrated HV startup-cell and the external HV resistor  $R_{HV}$  connected to the input voltage  $V_{IN}$  as shown in [Figure 3](#). The sensing is based on a periodic sampling instead of continuous sampling to reduce the power loss. The corresponding input voltage to the internal brownin and brownout current thresholds  $I_{HV\_BI}$  and  $I_{HV\_BO}$  can be adjusted via the external HV resistor  $R_{HV}$ .

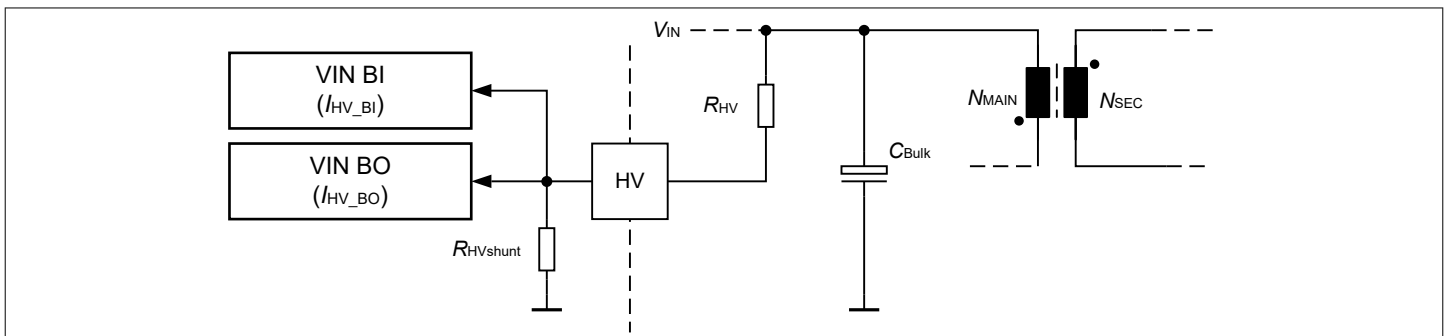

**Figure 3** HV pin sensing for brownin/brownout protection

### 3.3.2 HV sensing via VINP pin

The controller senses the rectified input line voltage via the VINP pin for line overvoltage protection by two resistors,  $R_{VINH}$  and  $R_{VINL}$  as shown in Figure 4.

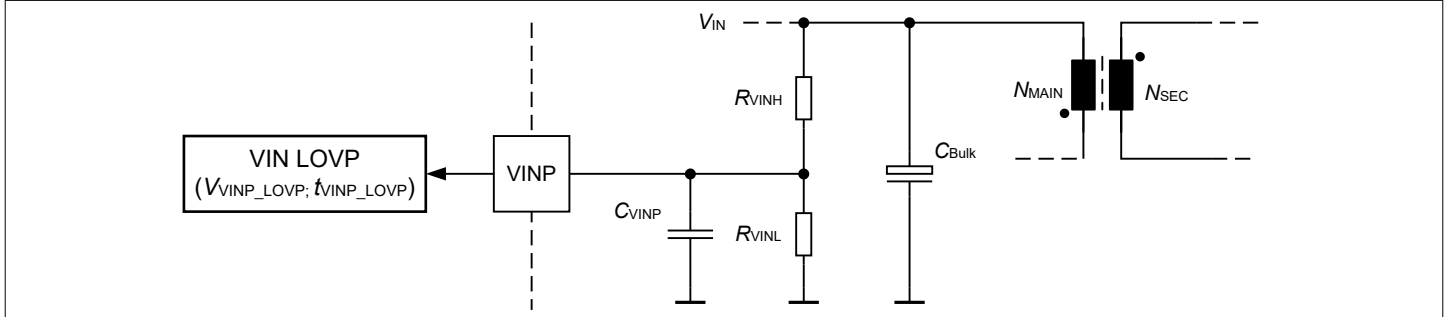

Figure 4 VINP pin sensing

### 3.3.3 Primary current sensing at CS pin

In the primary side controller, the primary transformer winding current is monitored by converting it to a voltage using the external shunt resistor  $R_{CS}$  as shown in Figure 5.

This information is used for the following features:

- Peak current limitation during soft-start
- Maximum peak current limitation OCP1 during normal operation
- Primary overcurrent protection OCP2 during fault condition

To avoid mis-triggering caused by a voltage spike across the external shunt resistor at the turn-on of the primary side power switch, a leading edge blanking (LEB) filter with  $t_{OCP1LEB}$  is integrated.

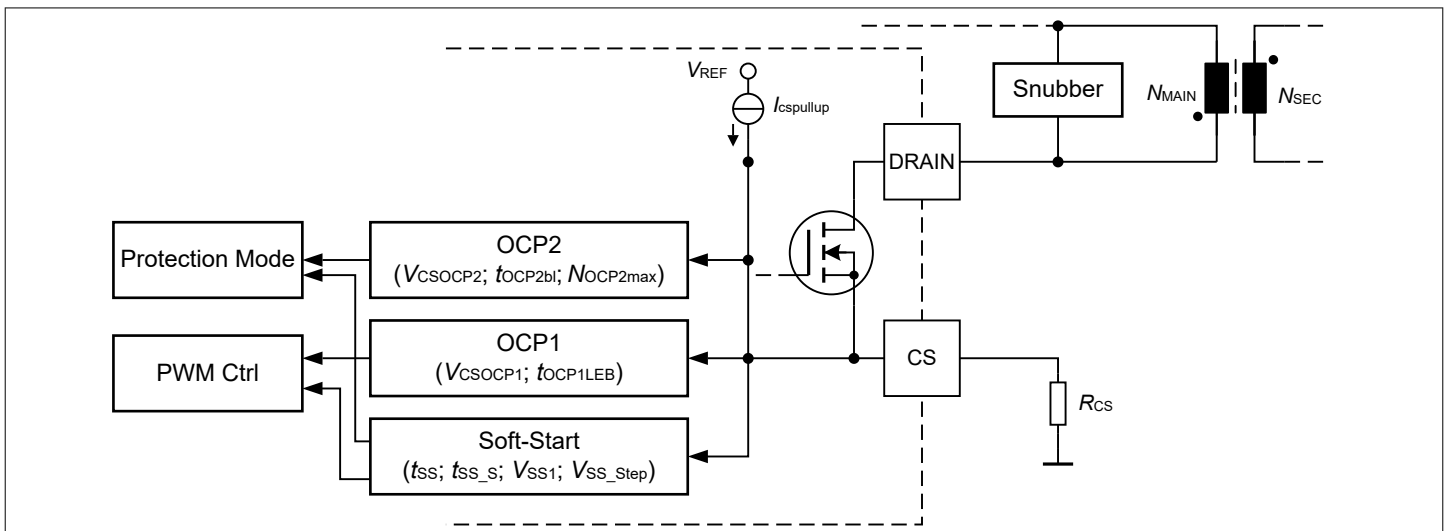

Figure 5 Primary current sensing at CS pin

### 3.3.4 Primary ZCDP sensing

The ZCDP pin enables the detection of zero-crossing during soft-start and also provides reflected output protection sensing via the auxiliary transformer winding (see Figure 6).

In the system, the voltage from the auxiliary winding is applied to the ZCDP pin through an RC network ( $R_{ZCDPH}$ ,  $R_{ZCDPL}$  and  $C_{ZCDP}$ ), which provides a time delay to the voltage from the auxiliary winding. Internally, this pin is connected to a zero-crossing detector, an output over/undervoltage detector and a ringing suppression time controller. The external diode  $D_{AUX}$  is added to block the negative voltage from the auxiliary winding.

During off-time of the primary power switch, the voltage at the ZCDP pin is monitored for output overvoltage and output undervoltage detection. The latter is only enabled after the soft-start. If the voltage is higher than the



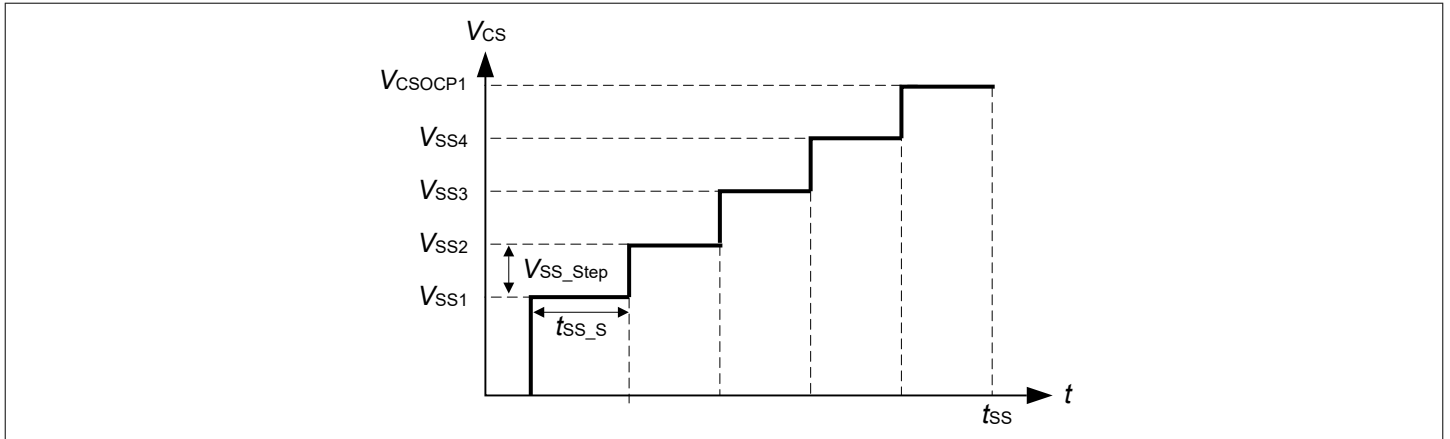

Figure 7 Maximum current sense voltage during soft-start

### 3.3.6 Normal operation

The following chapters describe the normal operation when secondary side has taken over the PWM control. This control is based on sensing the reflected voltage from primary side via the ZCDS pin. The control ensures that the timing of the SR power switch and the primary side power switch is synchronized under all conditions. A current injection function via the SR power switch enables ZVS operation on primary side. The control loop contains the integrated error amplifier and voltage reference together with the external configurable RC-network.

#### 3.3.6.1 Secondary take-over of control

Once the output voltage exceeds the threshold  $V_{VCCS_{on}}$ , the secondary side controller starts monitoring the voltage at the FB pin. As soon as the voltage at the FB pin exceeds a level of  $V_{FB_{start}}$ , the secondary side controller takes over control from the primary side controller. This is done in two steps:

- The secondary side controller signals to the primary side to stop switching.
- After a timeout of  $t_{ho}$ , the secondary side starts the closed loop operation.

#### 3.3.6.2 Secondary ZCDS sensing

The controller senses the ZCDS pin for SR operation as well as for valley and peak detection.

During the primary side turn-on phase, the controller clamps the ZCDS pin to the voltage at the VCCS pin. As a consequence, the flowing current represents only the reflected input voltage and is determined by the external resistor in this sensing path. This information is used for a feedforward compensation of the input voltage variation by adjusting the on-time for fast line transient response during the turn-on phase.

#### 3.3.6.3 Synchronous rectifier

The controller integrates a synchronous rectifier (SR) controller, which senses the voltage across the secondary side external switch at drain via the ZCDS pin. The sensed signal is compared with two threshold voltages to turn on at  $V_{NSN}$  and turn off at  $V_{ZCDS\_SROFF_{low}}$  the external switch to achieve optimum efficiency.

In hysteric mode, the SR operation is disabled.

#### 3.3.6.4 Self-adapting current injection for zero voltage switching

An additional SR turn-on pulse before turning on the primary side power switch is introduced, to inject current into the transformer for achieving ZVS condition at the primary switch. This occurs when the reflected input voltage on the secondary side is higher than  $V_{ZCDS\_mid}$  at the ZCDS pin. The controller activates the SR gate driver close to the target valley on the secondary side to insert a ZVS pulse. After the ZVS pulse, the transformer voltage swings to the opposite side.

The controller turns on the primary switch close to the lowest point of the primary drain voltage.

### 3.3.6.5 Closed loop operation

The controller senses the output voltage via the FB pin and compares it to an internal reference voltage  $V_{FBref}$ . An integrated operational transconductance amplifier (OTA) amplifies the error signal for external compensation at the EA pin.

In closed loop operation, the controller creates a primary gate pulse with a duration based on the EA voltage. The pulse generated uses a feedforward-path from the reflected input voltage, which is sensed at the ZCDS pin, to compensate for the effect of a varying input voltage on the pulse width.

### 3.3.7 Multi-mode operation

The controller optimizes efficiency by multiple operation modes. During normal operation, continuous switching is taking place according to the QR control law. The QR switching is limited by frequency limits for specific operating conditions (for example very high and very low loads). At light-load skip operation is introduced first before the hysteretic mode is entered.

#### 3.3.7.1 QR operation with frequency limits

During normal QR operation, the controller works with a digital signal processing circuit composing a target valley counter, a valley counter and a comparator, and an analog circuit composing a PWM generation unit. The three digital parts are key to implement a digital frequency reduction with decreasing load. The switch-on and -off time points are each determined by the digital circuit and the analog circuit, respectively. The input information of the zero-crossing signal and the target valley are needed to determine the switch-on while the error amplifier signal  $V_{EA}$  is necessary for the switch-off determination.

##### Target valley determination

The target valley number determines when to initiate a new switching cycle. This value depends on the error amplifier voltage  $V_{EA}$ , which represents the output power. A high output power results in a high  $V_{EA}$ , and a low output power leads to a low  $V_{EA}$ . Hence, according to  $V_{EA}$ , the target valley is changed to vary the off-time according to the output power.

The voltage  $V_{EA}$  is compared with three threshold voltages  $V_{EA\_LHC}$ ,  $V_{EA\_HLC}$  and  $V_{EA\_R}$  at each clock period of  $t_{valleyupdate}$ . The target valley is increased by one, is kept unchanged or is decreased by one, as shown in the table below.

**Table 2 Update of target valley**

$V_{EA}$	Target valley action
Always lower than $V_{EA\_LHC}$	Increase by one till $N_{valley\_max\_lowline}$ (low-line) or $N_{valley\_max\_highline}$ (high-line)
Once higher than $V_{EA\_LHC}$ , but always lower than $V_{EA\_HLC}$	Stop counting, no value changing
Once higher than $V_{EA\_HLC}$ , but always lower than $V_{EA\_R}$	Decrease by one till 1 (low-line) or $N_{valley\_min\_highline}$ (high-line)
Once higher than $V_{EA\_R}$	Set target valley immediately to 1 (low-line) or $N_{valley\_min\_highline}$ (high-line)

The target valley is limited to minimum and maximum values and therefore, the counter varies between 1 to  $N_{valley\_max\_lowline}$  (for low-line) or  $N_{valley\_min\_highline}$  to  $N_{valley\_max\_highline}$  (for high-line). When  $V_{EA}$  exceeds  $V_{EA\_R}$  voltage, the target valley is reset to the lowest possible value (with respect to line voltage) to allow the system to react rapidly to a sudden load increase. The target valley is also reset to the lowest possible value (with respect to line voltage) at the startup time to ensure an efficient maximum load startup. The use of two different thresholds  $V_{EA\_LHC}$  and  $V_{EA\_HLC}$  to count upward or downward is to prevent frequency jittering when the error amplifier voltage is close to a threshold.

##### Minimum target valley determination

To reduce the switching frequency difference between low- and high-line, a minimum valley is implemented. The minimum valley is set to 1 if the ZCDS current during the primary side pulse is below  $I_{ZCDS\_mid} - \Delta I_{ZCDS\_mid}$ , which represents low-line. For high-line, the minimum valley is set to  $N_{valley\_min\_highline}$  after the ZCDS current during the

primary side pulse is above  $I_{ZCDS\_mid} \cdot \Delta I_{ZCDS\_mid}$  determines a hysteresis with certain blanking time  $t_{ZCDS\_mid}$  to ensure stable AC line selection between low- and high-line.

### Valley counting

The controller senses peaks and valleys at the secondary side at the ZCDS pin:

- If ZVS is disabled, the valley counter is increased with every secondary side peak
- If ZVS is enabled, the valley counter is increased with every secondary side valley

### Initiation of a new switching cycle

A new switching cycle is initiated when the valley of the valley counter is equal to the target valley number. If the oscillation damps very quickly and the controller cannot detect any further valley, an internal timer generates internal events to increase the valley counter to achieve a frequency foldback.

### Avoidance of audible noise

Audible noise is avoided especially at light-load operation and overload condition by limiting the pulse width modulation (PWM) for minimum switching frequency  $f_{sw\_min}$ . During valley-switching operation, the frequency is foldback by increasing the number of valleys before triggering the next primary turn-on switching cycle.

A new switching cycle is started at the latest when the minimum switching frequency  $f_{sw\_min}$  is reached, regardless of the valley counter and  $V_{ZCDS}$ .

When operating at heavy load, the switching frequency is getting reduced by increasing the demagnetization time. If a maximum period of  $t_{CCMperiod}$  is hit, immediately the SR gate driver is turned off and a next primary switch turn-on cycle is triggered.

Both methods ensure that, for both light and heavy loads, the switching frequency stays above the defined level to avoid audible noise.

### Maximum switching frequency limitation

The maximum allowable switching frequency is limited internally. If the switching frequency is higher than  $f_{sw\_max}$ , the primary side PWM gate is only allowed to turn on at the next valley.

### Frequency jittering

The frequency jittering function helps to reduce conducted electromagnetic interference (EMI). When the soft-start period is over and the controller enters normal mode operation, the frequency jittering is enabled by superimposing a frequency jitter on the switching period.

The frequency jittering function is determined by the jitter repetition frequency  $f_{JITper}$ , considered as fraction of the switching frequency, and the amplitude in delta frequency change  $\Delta f_{JITamp}$ , considered as percentage number in relation to the operating switching frequency.

### 3.3.7.2 Skip operation

When the error amplifier voltage drops below  $V_{EA\_skip}$ , both primary side and SR switches remain in off-state. Switching resumes when the error amplifier voltage rises above  $V_{EA\_skip}$  again.

### 3.3.7.3 Hysteretic mode operation

At continuous light-load condition, the controller enters hysteretic mode (HM) to minimize the average power consumption. The hysteretic mode entry level is targeted for low range of output power. For determination of entering hysteretic mode, three conditions apply (see [Figure 8](#)):

- The error amplifier voltage is lower than the threshold of  $V_{EA\_EHM}$
- The target valley is  $N_{valley\_max\_lowline}$  for low-line or  $N_{valley\_max\_highline}$  for high-line
- The above two conditions remain after a certain blanking time  $t_{HM}$

After having entered the hysteretic mode, the error amplifier voltage rises as  $V_{out}$  starts to decrease due to the inactive PWM section. If the level  $V_{EA\_HMOn}$  is exceeded, one comparator observes the error amplifier voltage. In this case, the internal circuit is powered to resume switching. The turn-on of the primary side power MOSFET is triggered by the valley counter with a fixed target valley of  $N_{valley\_max\_lowline}$  for low-line and  $N_{valley\_max\_highline}$  for high-line. The turn-off is time-based with an input voltage compensation. If the output load is still low, the error amplifier voltage decreases as the switching transfers power from primary to secondary side. When the error amplifier voltage reaches the low threshold  $V_{EA\_HMOff}$ , the internal circuit is reset again and switching is disabled until the next

---

3 Functional description

time  $V_{EA}$  increases beyond the  $V_{EA\_HMon}$  threshold. In hysteretic mode, the error amplifier voltage is changing like a saw tooth between  $V_{EA\_HMOff}$  and  $V_{EA\_HMon}$ .

The error amplifier voltage immediately increases after a high load jump occurs. This is observed by a comparator with threshold  $V_{EA\_LHM}$ . As the voltage level for primary pulse generation is fixed to  $V_{EA\_PWM\_HM}$  during hysteretic mode operation, a certain load is needed that the error amplifier voltage can exceed  $V_{EA\_LHM}$ . After leaving hysteretic mode, continuous switching with regulation through  $V_{EA}$  is re-activated. In addition, the target valley is initialized to  $N_{valley\_max\_lowhline}$  (low-line) or  $N_{valley\_max\_highline}$  (high-line) immediately after leaving hysteretic mode.

If the load step increases, the error amplifier voltage even above  $V_{EA\_R}$ , the target valley is immediately changed to 1 (low-line) or  $N_{valley\_min\_highline}$  (high-line).

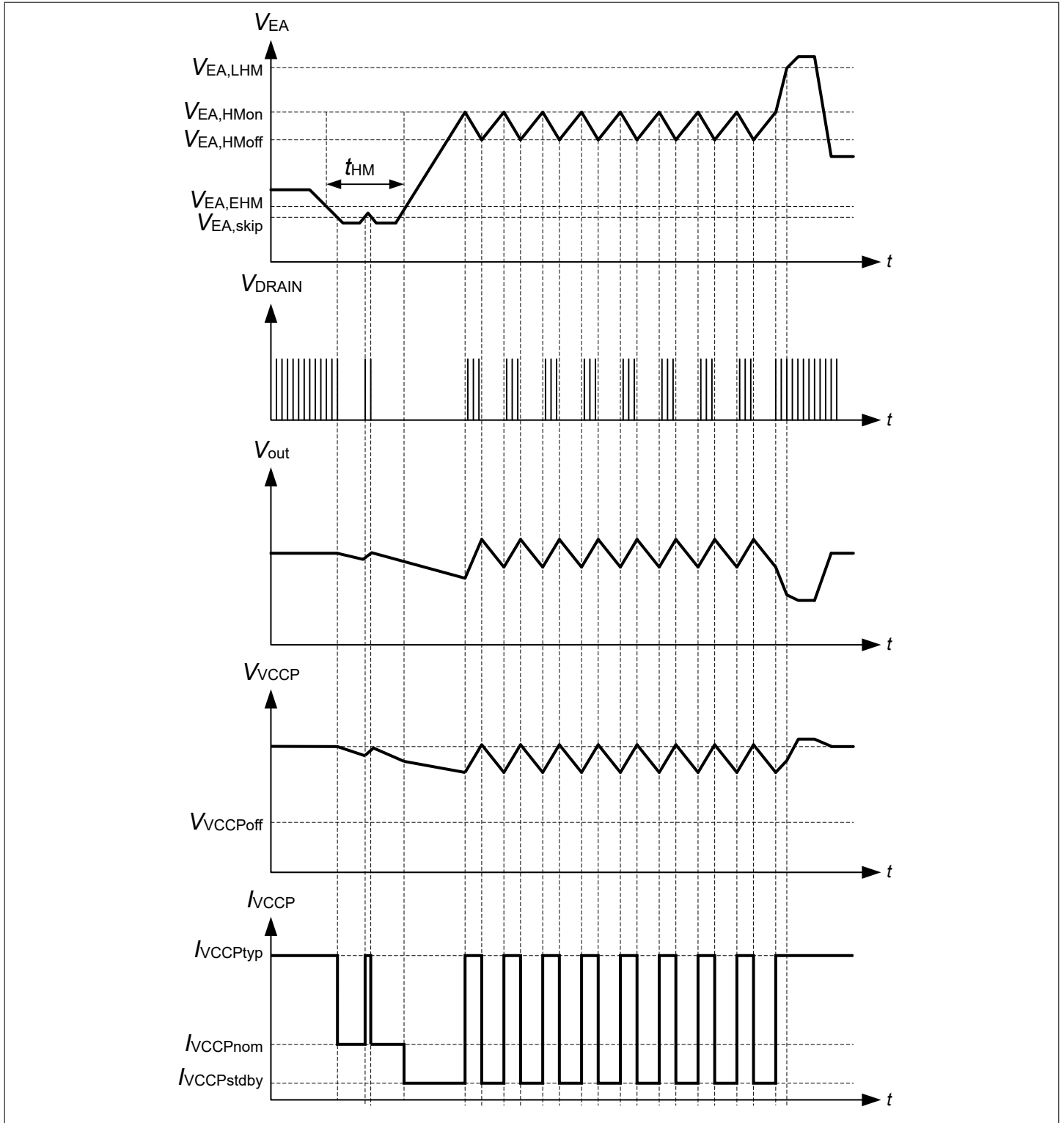

**Figure 8** Typical signals for entering, during and exiting hysteretic mode

### 3.3.8 Enable output signal

This feature supports the ability to reduce system power consumption by disabling the VINP sensing path during non-switching activity.

The following logic is used:

1. ENP logic = 1 if VINP sensing is enabled
2. ENP logic = 0 if
  - VINP sensing is disabled or
  - Controller is off due to low VCCP or protection trigger

### 3.4 Protection features

All protection features are forcing an auto-restart with a new soft-start sequence. After a protection is triggered, three different auto-restart modes apply.

#### 1) Non-switch auto-restart mode

The non-switch auto-restart mode provides no switching activity during the auto-restart phase, when fault detection is again enabled. After fault detection, the controller stops operation and enters a power saving mode. In this inactive mode, the  $V_{VCCP}$  is toggling between the  $V_{VCCPoff}$  and  $V_{VCCPon}$  thresholds controlled by the VCCP charging via the HV startup-cell. Every time when  $V_{VCCPon}$  threshold is exceeded, fault detection is triggered. If no further fault condition is detected, the controller starts with a soft-start sequence.

#### 2) Auto-restart mode

The auto-restart mode activates a soft-start sequence when the  $V_{VCCPon}$  threshold is exceeded and starts detecting for fault conditions. The soft-start switching is then stopped immediately if the fault conditions is still detected.

#### 3) Eight-skip auto-restart mode

The eight-skip auto-restart mode prolongs the inactive switching phase of the auto-restart mode by  $V_{VCCP}$  toggling eight times between the  $V_{VCCPoff}$  and  $V_{VCCPon}$  thresholds before initiating a soft-start and detecting for fault conditions.

The protection features and assigned auto-restart modes are summarized in the following table.

**Table 3 Protection features**

Protection features	Startup phase	Continuous switching	Hysteretic mode		Protection mode
	(Open-loop operation)	(Closed-loop operation)	Switching	Non-switching	
Primary VCCP overvoltage and undervoltage protection	√	√	√	√ <sup>1)</sup>	Auto-restart
Primary VCCP short to GNDP protection	√	√	√	n.a	No status
Primary maximum peak current limitation (OCP1max)	√	√	√	n.a	HW reset state
Primary 2nd level overcurrent (OCP2) protection	√	√	√	n.a	Eight-skip auto-restart
Primary overtemperature protection	√	√	√	n.a	Non-switch auto-restart

**(table continues...)**

**Table 3 (continued) Protection features**

Primary brownin and brownout protection	√	√	√	n.a	Non-switch auto-restart
Primary line overvoltage protection	√	√	√	n.a	Non-switch auto-restart
Primary output overvoltage protection	√	√	√	n.a	Eight-skip auto-restart
Primary output undervoltage protection	√	n.a	n.a	n.a	Eight-skip auto-restart
Primary ZCDP short to GNDP protection	√	n.a	n.a	n.a	Auto-restart
Primary closed-loop timeout protection	√	n.a	n.a	n.a	Eight-skip auto-restart
Secondary VCCS overvoltage	n.a	√	√	n.a	Auto-restart
Secondary VCCS undervoltage	n.a	√	√	n.a	Auto-restart
Secondary VCCS UVLO detection	√	√	√	√	Secondary side off/ powered down
Secondary overload / open-loop (EA pin overvoltage)	n.a	√	n.a	n.a	Auto-restart
Secondary output overvoltage (at FB pin) <sup>2)</sup>	n.a	√	√	wake-up	Auto-restart

1) Only VCCP undervoltage protection.

2) Activated only for corresponding product versions, see [Chapter 3.5.2](#)

### 3.4.1 Primary side protection features

#### 3.4.1.1 Primary VCCP overvoltage and undervoltage protection

During operation, if  $V_{VCCP}$  is either below  $V_{VCCPoff}$  for  $t_{VCCPoff}$  or above  $V_{VCCP\_OVP}$  for  $t_{VCCP\_OVP\_B}$ , the primary side power MOSFET is kept off. After the VCCP voltage falls below the threshold  $V_{VCCPoff}$ , a new startup sequence is activated.

#### 3.4.1.2 Primary VCCP short to GND protection

To limit the power dissipation of the startup circuit at  $V_{VCCP}$  short to GNDP condition, the  $V_{VCCP}$  charging current is limited to a lower level of  $I_{VCCPCharge1}$ . With such a low current, the power loss of the controller is limited.

#### 3.4.1.3 Primary maximum peak current limitation (OCP1max)

A current limit comparator provides a cycle by cycle OCP1 maximum peak current limitation on primary side. The source current of the internal switch is measured via the external shunt resistor  $R_{CS}$  connected at the CS pin. If the voltage  $V_{CS}$  exceeds an internal dynamic voltage limit  $V_{CSOCP1}(t)$ , the comparator immediately turns off the primary

side switch. The dynamic voltage threshold  $V_{CSOCP1}(t)$  provides a propagation delay compensation by avoiding a higher limited maximum peak current at high-line condition.

#### 3.4.1.4 Primary maximum power limitation

The minimum target valley increases for high-line condition to  $N_{valley\_min\_highline}$ , to reduce the delta between limiting the maximum power at low-line and high-line conditions.

#### 3.4.1.5 Primary 2nd level overcurrent (OCP2) protection

A further comparator  $V_{CSOCP2}$  is implemented at the CS pin to detect an extremely high primary switch current, which can occur if transformer windings are shorted or if the secondary side is shorted. To avoid an accidental trigger, a spike blanking time  $t_{OCP2bl}$  is implemented.

A counter counts the number of occurrences of the short winding condition. If there is  $N_{OCP2max}$  consecutive occurrence, the short winding condition is asserted, and the system enters the OCP2 protection mode.

#### 3.4.1.6 Primary CS floating protection

If the CS pin is floating, the internal CS pull up current source  $I_{CSpullup}$  charges up the CS pin and trigger the OCP2 protection.

#### 3.4.1.7 Primary overtemperature protection

If the junction temperature of primary side controller exceeds  $T_{JPOTP}$ , the controller enters overtemperature protection (OTP) auto-restart mode. The controller can only recover from OTP if the controller's junction temperature drops below the overtemperature hysteresis trip point determined by  $T_{JPOTP\_hys}$  lower than the overtemperature trigger point.

#### 3.4.1.8 Primary brownin and brownout protection

When the controller is activated, the brownin monitoring is enabled at the HV pin. In addition, the primary side controller is checked for  $T_{JPOTP}$  condition. When the  $T_j$  temperature is below  $T_{JPOTP}$ , the HV startup-cell turns on comparing the current  $I_{HV}$  at the HV pin with the current threshold  $I_{HV\_BI}$ . If one of two conditions is not met, the internal primary side power switch is not activated, and the primary side controller activates another round of auto-restart. This process continues until both conditions are met.

When the controller enters active mode, the  $V_{IN}$  voltage is sensed periodically with a sampling period  $t_{DCHVsmp}$ . The depletion cell is then activated for a fixed sampling time  $t_{DCHVsmt}$ .

If  $I_{HV}$  is less than the HV brownout current threshold  $I_{HV\_BO}$  during sampling time, a brownout event is considered to be occurred. If the event occurs consecutively for  $N_{HVBO}$  times, the protection triggers auto-restart mode.

#### 3.4.1.9 Primary line overvoltage protection

The AC line overvoltage protection (LOVP) is detected by the sensing bus capacitor voltage through the VINP pin via the voltage divider resistors,  $R_{VINH}$  and  $R_{VINL}$ . When the  $V_{VINP}$  voltage is higher than the line overvoltage threshold  $V_{VINP\_LOVP}$ , the controller enters protection mode until  $V_{VINP}$  is lower than  $V_{VINP\_LOVP}$ . This protection can be disabled by connecting the VINP pin to GNDP.

#### 3.4.1.10 Primary output overvoltage protection

If the secondary side controller does not take over control, the primary side controller stops switching at an overvoltage of the reflected output voltage at  $V_{ZCDP\_OVP}$  and triggers an auto-restart mode.

This protection is disabled once the secondary side controller has taken over control successfully.

#### 3.4.1.11 Primary output undervoltage protection

The primary output undervoltage protection is enabled after the soft-start time and stops the primary side controller switching for an undervoltage of the reflected output voltage exceeding  $V_{ZCDP\_UVP}$ . After  $N_{ZCDPUVP}$  consecutive switching cycles with detecting undervoltage conditions, an auto-restart is triggered.

This protection is disabled once the secondary side controller has taken over control successfully.

### 3.4.1.12 Primary ZCDP short to GNDP protection

When the primary side controller is powered, the ZCDP pin is sensed for any short. During the system configuration phase, if ZCDP is less than the ZCDP short to GNDP threshold  $V_{ZCDP\_short}$ , auto-restart mode is triggered. This protection is disabled after the primary side controller configuration loading is completed.

### 3.4.1.13 Primary close-loop timeout protection

After the primary side controller starts its open-loop operation, it starts the close-loop timeout  $t_{pto}$  counter. If no handshaking is detected from the secondary side controller at the end of the timeout, the primary side controller triggers eight-skip auto-restart mode.

## 3.4.2 Secondary side protection functions

### 3.4.2.1 Secondary VCCS undervoltage and overvoltage protection

When  $V_{VCCS}$  is below  $V_{VCCS\_UVP}$  for  $t_{VCCS\_UVP\_B}$  or exceeding  $V_{VCCS\_OVP}$  for  $t_{VCCS\_OVP\_B}$ , an eight-skip auto-restart is initiated.

### 3.4.2.2 Secondary output overvoltage protection

When the feedback pin exceeds the threshold  $V_{FBOVP}$  for longer than the filter time  $t_{FBOVPfil}$ , the controller enters eight-skip auto-restart.

**Note:** The overvoltage protection at FB pin is only activated only for corresponding product versions, see [Chapter 3.5.2](#).

### 3.4.2.3 Secondary open-loop protection

If there is an open control loop or an output overload, the error amplifier voltage is pulled up. When  $V_{EA}$  exceeds  $V_{EA\_OLP}$  after a blanking time of  $t_{EA\_OLP\_B}$ , the controller enters eight-skip auto-restart mode.

## 3.5 Hardware configuration by external resistor setting

The controller provides hardware (HW) configuration of the primary and secondary side via the readout of external resistors. After initial start, when the voltage at the VCCP pin and VCCS pin are exceeding the UVLO on-thresholds, the readout is performed on the primary side at the ZCDP pin and on the secondary side at the CONF0 and CONF1 pin.

### 3.5.1 Primary side configuration

**Table 4 Primary side configuration options**

Option	$[R_{ZCDL(min)} ; R_{ZCDL(max)}]$	VINP brownin threshold	VINP brownout threshold
1	[1.00 kΩ ; 1.05 kΩ]	$V_{VINP\_BI\_OPT0}$	$V_{VINP\_BO\_OPT0}$
2	[1.87 kΩ ; 2.70 kΩ]	$V_{VINP\_BI\_OPT1}$	$V_{VINP\_BO\_OPT1}$
3	[4.30 kΩ ; 5.00 kΩ]	$V_{VINP\_BI\_OPT2}$	$V_{VINP\_BO\_OPT2}$
4	[9.20 kΩ ; 9.50 kΩ]	$V_{VINP\_BI\_OPT3}$	$V_{VINP\_BO\_OPT3}$

On primary side, the thresholds for brownin protection and brownout protection are configured by the resistor  $R_{ZCDPL}$  at the ZCDP pin. Four configurable options are supported for the paired brownin (BI) and brownout (BO) threshold.

BI and BO are observed by turning on the integrated HV startup-cell at the HV pin. The external HV startup resistor at the HV pin is then connected to the internal shunt resistor  $R_{HVshunt}$  and building a resistor divider ( see [Figure 3](#)).

The different thresholds for BI and BO on system level are set by adjusting  $R_{HVshunt}$ .

The following table shows the options that can be set by  $R_{ZCDL}$  connected between the ZCDP pin and ground.

**Table 5 Primary side configuration options**

Option	$[R_{ZCDL(min)} ; R_{ZCDL(max)}]$	Brownin current threshold	Brownout current threshold	Internal $R_{HVshunt}$ for HV sensing
1	[1.00 kΩ ; 1.05 kΩ]	2.00 mA	1.40 mA	0.50 kΩ
2	[1.87 kΩ ; 2.70 kΩ]	1.00 mA	0.70 mA	1.00 kΩ
3	[4.30 kΩ ; 5.00 kΩ]	0.67 mA	0.47 mA	1.50 kΩ
4	[9.20 kΩ ; 9.50 kΩ]	0.50 mA	0.35 mA	2.00 kΩ

### 3.5.2 Secondary side configuration

The secondary side controller is configured using two resistors at the CONF0 and CONF1 pins.

**Note:** If the CONFx pin is short circuit or left open, auto-restart protection mode is entered. A connected capacitor should be < 100 pF.

#### Hardware configuration for CONF0 pin

The CONF0 pin provides the configuration of six options depending on the connected resistor  $R_{SET0}$  for the transformer turns ratio  $N_{MAIN} / N_{SEC}$  between the main primary side input winding and the main secondary side output winding. This information is used for measuring the reflected input voltage via the ZCDS pin.

#### Hardware configuration for CONF1 pin

The CONF1 pin provides the configuration of six options depending on the connected resistor  $R_{SET1}$  for different parameter settings.

The following table shows the supported options for the resistor  $R_{SETx}$  at the CONFx pin:

**Table 6 Options for  $R_{SET0}$  and  $R_{SET1}$**

Option	$R_{SETx}$	Turns ratio $N_{MAIN} / N_{SEC}$ ( $R_{SET0}$ )	Parameter set ( $R_{SET1}$ )
1	3.9 kΩ	5	RSET1_1
2	6.8 kΩ	6	RSET1_2
3	12.0 kΩ	7	RSET1_3
4	18.0 kΩ	8	RSET1_4
5	27.0 kΩ	9	RSET1_5
6	39.0 kΩ	10	RSET1_6

Following parameter settings can be configured based on the part number with specific feature code (see Table 31):

**Table 7 RSET1\_x parameter settings for feature code LM-V001**

Parameter	Symbol	RSET1_1	RSET1_2	RSET1_3	RSET1_4	RSET1_5	RSET1_6
Minimum valley for high-line	$N_{valley\_min\_highline}$	3	3	3	3	3	3
Minimum valley for low-line	$N_{valley\_min\_lowline}$	1	1	1	1	1	1
Maximum valley for high-line	$N_{valley\_max\_highline}$	10	10	10	10	10	10

(table continues...)

**Table 7 (continued) RSET1\_x parameter settings for feature code LM-V001**

Parameter	Symbol	RSET1_1	RSET1_2	RSET1_3	RSET1_4	RSET1_5	RSET1_6
Maximum valley for low-line	$N_{\text{valley\_max\_lowline}}$	8	8	8	8	8	8
EA threshold to enter hysteretic mode	$V_{\text{EA\_EHM}}$	0.586 V	0.586 V	0.605 V	0.605 V	0.624 V	0.624 V
EA voltage for wakeup in hysteretic mode	$V_{\text{EA\_HMOon}}$	1.20 V	1.20 V	1.20 V	1.25 V	1.20 V	1.25 V
EA voltage for off-phase in hysteretic mode	$V_{\text{EA\_HMOff}}$	0.9 V	0.9 V	0.9 V	0.8 V	0.9 V	0.8 V
EA voltage during hysteretic mode	$V_{\text{EA\_PWM\_HM}}$	0.8 V	0.9 V	0.9 V	0.8 V	0.9 V	0.8 V
FB overvoltage protection mode	PM_FB_OVP	Disabled	Disabled	Disabled	Disabled	Disabled	Disabled

**Table 8 RSET1\_x parameter settings for feature code LM-V101**

Parameter	Symbol	RSET1_1	RSET1_2	RSET1_3	RSET1_4	RSET1_5	RSET1_6
Minimum valley for high-line and low-line	$N_{\text{valley\_min\_highline}}$	1	1	1	1	1	1
	$N_{\text{valley\_min\_lowline}}$						
Maximum valley for high-line and low-line	$N_{\text{valley\_max\_highline}}$	11	10	9	8	12	13
	$N_{\text{valley\_max\_lowline}}$						
EA threshold to enter hysteretic mode	$V_{\text{EA\_EHM}}$	0.586 V	0.586 V	0.567 V	0.567 V	0.605 V	0.624 V
EA voltage for wakeup in hysteretic mode	$V_{\text{EA\_HMOon}}$	1.20 V	1.20 V	1.20 V	1.20 V	1.20 V	1.20 V
EA voltage for off-phase in hysteretic mode	$V_{\text{EA\_HMOff}}$	0.9 V	0.9 V	0.9 V	0.8 V	0.9 V	0.8 V
EA threshold to enter skip mode	$V_{\text{EA\_skip}}$	0.5 V	0.5 V	0.45 V	0.45 V	0.5 V	0.5 V
EA voltage during hysteretic mode	$V_{\text{EA\_PWM\_HM}}$	0.8 V	0.8 V	0.7 V	0.7 V	0.9 V	0.9 V
FB overvoltage protection mode	PM_FB_OVP	Enabled	Enabled	Enabled	Enabled	Enabled	Enabled

## 4 Characteristics

All signals are measured with respect to the GNDP or GNDS pin, respectively. The voltage levels are valid if other ratings are not violated.

### 4.1 Absolute maximum ratings

Stresses above the values listed below may cause permanent damage to the device. Exposure to absolute maximum rating conditions for given periods may affect device reliability. Maximum ratings are absolute ratings; exceeding anyone of these values may cause irreversible damage to the device.

**Table 9 Absolute maximum ratings**

Parameter	Symbol	Values			Unit	Note or condition
		Min.	Typ.	Max.		
Drain voltage (ICE18xx)	$V_{DRAIN}$	–	–	800	V	$T_J = 25\text{ °C}$
Drain voltage (ICE19xx)	$V_{DRAIN}$	–	–	950	V	$T_J = 25\text{ °C}$
Voltage at HV pin	$V_{HV}$	-0.5	–	950	V	Permanently applied as DC value
Current at HV pin	$I_{HV}$	–	–	10	mA	Internally limited by HV startup-cell
Voltage at VCCP pin	$V_{VCCP}$	-0.3	–	32	V	–
Voltage at VINP pin	$V_{VINP}$	-0.3	–	5.5	V	Permanently applied as DC value
Voltage at ZCDP pin	$V_{ZCDP}$	-0.3	–	5	V	Permanently applied as DC value
Voltage at ENP pin	$V_{ENP}$	-0.3	–	$V_{VCCP} + 0.3$	V	Permanently applied as DC value
Voltage at CS pin	$V_{CS}$	-0.3	–	3.6	V	Permanently applied as DC value
Current at CS pin	$-I_{CSclp}$	–	–	1.3	mA	Permanently applied as DC value. $V_{CS} = -0.45\text{ V}$
Voltage at VCCS pin	$V_{VCCS}$	-0.3	–	27	V	Permanently applied as DC value
Voltage at ZCDS pin	$V_{ZCDS}$	-0.3	–	17	V	Permanently applied as DC value
Current at ZCDS pin	$I_{ZCDS}$	–	–	8	mA	–
Voltage at GDSR pin	$V_{GDSR}$	-0.3	–	$V_{VCCS} + 0.3$	V	Permanently applied as DC value
Voltage at FB pin	$V_{FB}$	-0.3	–	5	V	Permanently applied as DC value
Voltage at EA pin	$V_{EA}$	-0.3	–	5	V	Permanently applied as DC value
Voltage at CONF0 pin	$V_{CONF0}$	-0.3	–	3.6	V	Permanently applied as DC value
Voltage at CONF1 pin	$V_{CONF1}$	-0.3	–	3.6	V	Permanently applied as DC value
Maximum DC current at any pins except for DRAIN and CS pin	–	-10	–	10	mA	–
Junction temperature	$T_J$	-40	–	150	°C	–
Storage temperature	$T_{STORE}$	-55	–	150	°C	–

(table continues...)

**Table 9** (continued) Absolute maximum ratings

Parameter	Symbol	Values			Unit	Note or condition
		Min.	Typ.	Max.		
Soldering temperature	$T_{\text{Sold}}$	–	–	260	°C	Pb-free reflow soldering according to IPC/JEDEC J-STD-020
ESD HBM capability	$V_{\text{HBM}}$	–	–	2	kV	Human body model according to ANSI/ESDA/JEDEC JS-001-2012
ESD CDM capability	$V_{\text{CDM}}$	–	–	500	V	Charged device model according to JESD22-C101F
Latch-up capability	$I_{\text{LU}}$	–	–	100	mA	According to JESD78D, 125 °C (Class II) temperature

## 4.2 Package characteristics

**Table 10** Package characteristics

Parameter	Symbol	Values			Unit	Note or condition
		Min.	Typ.	Max.		
Thermal resistance from junction to ambient	$R_{\text{thJA1}}$	–	84.7	–	K/W	Setup according to the JEDEC standard JESD51 and using minimum drain pin copper area in a 2 oz copper single sided PCB. $T_{\text{A}} = 50 \text{ °C}$ , $T_{\text{J}} = 125 \text{ °C}$ for power switch
Thermal resistance from junction to ambient	$R_{\text{thJA2}}$	–	66.9	–	K/W	Setup according to the JEDEC standard JESD51 and soldering to 232 mm <sup>2</sup> (0.36 sq) drain pin copper area in a 2 oz copper single sided PCB. $T_{\text{A}} = 50 \text{ °C}$ , $T_{\text{J}} = 125 \text{ °C}$ for power switch
Creepage distance between HV to GNDP-related pins	$CRP_{\text{HV\_GNDP}}$	1.57	–	–	mm	–
Creepage distance between DRAIN to GNDP-related pins	$CRP_{\text{DRAIN\_GN DP}}$	3.52	–	–	mm	–
Creepage distance between isolated primary to secondary related pins	$CRP_{\text{PSiso}}$	8.19	–	–	mm	Pin 10 and pin 27 not connected

### 4.3 Operating conditions

The table below shows the operating range, in which the electrical characteristics shown in the next chapter are valid.

**Table 11** Operating conditions

Parameter	Symbol	Values			Unit	Note or condition
		Min.	Typ.	Max.		
Junction temperature	$T_J$	-40	–	125	°C	–
Supply voltage at VCCP pin	$V_{VCCP}$	$V_{VCCPoff(max)}$	–	$V_{VCCP\_OV}$ P(min)	V	–
Supply Voltage at VCCS pin	$V_{VCCS}$	$V_{VCCS\_UV}$ P(max)	–	$V_{VCCS\_OV}$ P(min)	V	–
Voltage at HV pin	$V_{HV}$	-0.3	–	855	V	–
Voltage at CS pin	$V_{CS}$	-0.3	–	$V_{CSOCP2(max)}$	V	$V_{CSOCP1} = 0.8$ V, negative voltage lower needs to respect the negative maximum clamping current $-I_{CSclp}$
Clamp current of CS pin	$-I_{CSclp}$	–	–	2.5	mA	Permanently applied as DC value
Voltage at ENP pin	$V_{ENP}$	-0.3	–	13	V	–
Voltage at ZCDS pin	$V_{ZCDS}$	-0.3	–	$V_{VCCS\_OV}$ P(min) + 0.7 V	V	–
Voltage at GDSR pin	$V_{GDSR}$	-0.3	$V_{GDSRclm}$ P	11	V	–
Voltage at all the pins except for DRAIN, HV, VCCP, VCCS, CS, ENP, ZCDS, and GDSR pin	–	-0.3	–	3.3	V	–
External capacitance at ZCDP pin	$C_{ZCDPL}$	–	–	100	pF	–
External bottom resistor tolerance at ZCDP pin	$\Delta R_{ZCDPL}$	-5	–	+5	%	–
Current into ZCDS pin	$I_{ZCDS}$	0.8	–	6.0	mA	Clamp current during primary side pulse while $V_{ZCDS} > V_{VCCS}$
External capacitance at CONFx pin	$C_{CONFx}$	–	–	100	pF	–
External resistor tolerance at CONFx pin	$\Delta R_{SETx}$	-1	–	+1	%	–
Flyback resonant period	$t_{DCM}$	600	–	5000	ns	–

## 4.4 Electrical characteristics

The electrical characteristics involve the spread of values given within the specified supply voltage and junction temperature range  $T_J$  from  $-40\text{ °C}$  to  $125\text{ °C}$ . Typical values represent the median values related to  $T_J = 25\text{ °C}$ . All primary side voltages refer to GNDDP, and the assumed supply voltage is  $V_{VCCP} = 14\text{ V}$  if not otherwise specified. All secondary side voltages refer to GNDS, and the assumed supply voltage is  $V_{VCCS} = 12\text{ V}$  if not otherwise specified.

### 4.4.1 Power supply primary (VCCP pin)

**Table 12** Electrical characteristics of power supply (VCCP pin)

Parameter	Symbol	Values			Unit	Note or condition
		Min.	Typ.	Max.		
VCCP turn-on threshold	$V_{VCCPon}$	19	20	21	V	$dV_{VCCP} / dt = 0.2\text{ V/ms}$
VCCP turn-off threshold	$V_{VCCPoff}$	8.55	9.00	9.45	V	$dV_{VCCP} / dt = -0.2\text{ V/ms}$
VCCP turn-off blanking time	$t_{VCCPoff}$	30	50	70	$\mu\text{s}$	<sup>1)</sup> , 1 V overdrive
VCCP off-state quiescent current	$I_{VCCPoff}$	–	165	340	$\mu\text{A}$	$V_{VCCP} < V_{VCCPon(min)} - 0.3\text{ V}$
VCCP supply current without gate drive	$I_{VCCPnom}$	–	1.4	–	mA	<sup>1)</sup> , IC self supply excluding gate drive currents
VCCP supply current in typical operation (ICE183xx)	$I_{VCCPtyp}$	–	2.50	2.90	mA	<sup>1)</sup> , $f_{swGDx} = 100\text{ kHz}$
VCCP supply current in typical operation (ICE184xx)	$I_{VCCPtyp}$	–	3.20	3.60	mA	<sup>1)</sup> , $f_{swGDx} = 100\text{ kHz}$
VCCP supply current in typical operation (ICE186xx)	$I_{VCCPtyp}$	–	3.54	3.94	mA	<sup>1)</sup> , $f_{swGDx} = 100\text{ kHz}$
VCCP supply current in typical operation (ICE193xx)	$I_{VCCPtyp}$	–	2.60	3.0	mA	<sup>1)</sup> , $f_{swGDx} = 100\text{ kHz}$
VCCP supply current in stand-by mode with ENP high	$I_{VCCPstdbyENP}$	–	380	450	$\mu\text{A}$	<sup>1)</sup> , $V_{ENS} > V_{ENS\_H}$ , Sleep phase, $T_J < 50\text{ °C}$
VCCP supply current in stand-by mode	$I_{VCCPstdby}$	–	210	250	$\mu\text{A}$	<sup>1)</sup> , Sleep phase, $T_J < 50\text{ °C}$
VCCP supply current in auto-restart mode (ARM)	$I_{VCCParm}$	–	200	500	$\mu\text{A}$	Sleep phase, $T_J < 50\text{ °C}$
VCCP overvoltage threshold	$V_{VCCP\_OVP}$	28.9	30.4	31.9	V	–
VCCP overvoltage blanking time	$t_{VCCP\_OVP\_B}$	36	60	84	$\mu\text{s}$	<sup>1)</sup>

4 Characteristics

1) Not subject to production test - verified by design/characterization

### 4.4.2 High voltage (HV pin)

**Table 13** Electrical characteristics of HV pin

Parameter	Symbol	Values			Unit	Note or condition
		Min.	Typ.	Max.		
Leakage current at HV pin	$I_{HVLK}$	–	–	10	μA	$V_{HV} = 800\text{ V}$ , HV startup-cell disabled
DC high voltage sampling time	$t_{DCHVsmt}$	18	20	22	μs	1)
DC high voltage sampling period	$t_{DCHVsmp}$	900	1000	1100	μs	1), During active phase
VCCP threshold for safe VCCP charging without short-circuit	$V_{VCCPstart}$	–	–	1.8	V	–
Initial VCCP charge current	$I_{VCCPCharge1}$	0.33	0.78	1.65	mA	$V_{VCCP} < V_{VCCPstart}$
Clamped VCCP charge current	$I_{VCCPCharge2}$	2.3	5.0	9.0	mA	$V_{VCCP} > V_{VCCPstart}$ , $R_{HV} = 50\text{ k}\Omega$ , $V_{IN} = 600\text{ V}$
HV Brownin current threshold	$I_{HV\_BI}$	1.88	2.00	2.12	mA	2), Option 1
HV Brownout current threshold	$I_{HV\_BO}$	1.31	1.40	1.49	mA	2), Option 1
HV Brownin current threshold	$I_{HV\_BI}$	0.94	1.00	1.06	mA	2), Option 2
HV Brownout current threshold	$I_{HV\_BO}$	0.65	0.70	0.75	mA	2), Option 2
HV Brownin current threshold	$I_{HV\_BI}$	0.63	0.67	0.71	mA	2), Option 3
HV Brownout current threshold	$I_{HV\_BO}$	0.44	0.47	0.50	mA	2), Option 3
HV Brownin current threshold	$I_{HV\_BI}$	0.47	0.50	0.54	mA	2), Option 4
HV Brownout current threshold	$I_{HV\_BO}$	0.33	0.35	0.38	mA	2), Option 4
HV Brownout detection blanking	$N_{HVBO}$	–	4	–	cycle	3), Consecutive sampling cycles to trigger brownout protection

1) Not subject to production test - verified by design/characterization

2) Configurable, see [Table 5](#)

3) Not subject to production test - verified by design/characterization

### 4.4.3 Current sensing primary (CS pin)

**Table 14** Electrical characteristics of CS pin

Parameter	Symbol	Values			Unit	Note or condition
		Min.	Typ.	Max.		
CS pin pull-up current	$I_{CSpullup}$	0.8	1.0	1.2	uA	–
OCP1 maximum peak current limitation	$V_{CSOCP1}$	0.70	0.76	0.82	V	–
Leading edge blanking time	$t_{OCP1LEB}$	154	220	286	ns	–
OCP2 turn-off threshold	$V_{CSOCP2}$	1.04	1.10	1.16	V	–
OCP2 blanking time	$t_{OCP2bl}$	28	40	52	ns	1)
Max allowable OCP2 consecutive switching cycles	$N_{OCP2max}$	–	3	–	–	1)
Abnormal CS voltage sample period	$t_{CS\_STG\_SAM}$	4.5	5	5.5	μs	1)
Number of pulses used for CS pin short protection	$N_{CS\_STG}$	–	3	–	–	1)
Soft-start time	$t_{ss}$	10.8	12.0	13.2	ms	1)
Soft-start time step	$t_{ss\_s}$	2.7	3.0	3.3	ms	1)
Internal regulation voltage at CS pin for the first step	$V_{SS1}$	0.27	0.30	0.33	V	–
Internal regulation voltage step at CS pin for soft-start	$V_{SS\_Step}$	0.135	0.150	0.165	V	–
Maximum on-time during open-loop operation	$t_{OnMax}$	31.5	35.0	38.5	μs	1)
Maximum off-time during open-loop operation	$t_{OffMax}$	38.2	42.5	46.8	μs	1)
Close-loop timeout time	$t_{pto}$	36	40	44	ms	1)

1) Not subject to production test - verified by design/characterization

#### 4.4.4 Primary zero-crossing detection and output voltage measurement (ZCDP pin)

**Table 15** Electrical characteristics of ZCDP pin

Parameter	Symbol	Values			Unit	Note or condition
		Min.	Typ.	Max.		
ZCDP zero-crossing threshold	$V_{ZCDPthr}$	70	100	130	mV	Falling edge
ZCDP long ringing suppression threshold	$V_{ZCDPRS}$	0.27	0.30	0.33	V	–
ZCDP ringing suppression time	$t_{ZCDPrs}$	1700	2000	2300	ns	1), $V_{ZCDP} > V_{ZCDPRS}$
ZCDP long ringing suppression time	$t_{ZCDPrs\_SS}$	22.5	25.0	27.5	μs	1), $V_{ZCDP} < V_{ZCDPRS}$
ZCDP output overvoltage threshold	$V_{ZCDP\_OVP}$	2.05	2.20	2.35	V	–
ZCDP output overvoltage blanking	$N_{ZCDPovp}$	–	3	–	cycle	1)
ZCDP output undervoltage threshold	$V_{ZCDP\_UVP}$	0.45	0.50	0.55	V	–
ZCDP output undervoltage blanking	$N_{ZCDPuvp}$	–	3	–	cycle	1)
ZCDP short to GNDP threshold	$V_{ZCDP\_short}$	70	100	130	mV	

1) Not subject to production test - verified by design/characterization

#### 4.4.5 Bus voltage sensing primary (VINP pin)

**Table 16** Electrical characteristics of VINP pin

Parameter	Symbol	Values			Unit	Note or condition
		Min.	Typ.	Max.		
Line overvoltage threshold	$V_{VINP\_LOVP}$	2.68	2.80	2.92	V	–
Line overvoltage blanking	$t_{VINP\_LOVP}$	225	250	275	μs	1)
VINP Input leakage current	$I_{VINPLK}$	-200	–	200	nA	–

1) Not subject to production test - verified by design/characterization

#### 4.4.6 Primary output enable control (ENP pin)

**Table 17** Electrical characteristics of ENP pin

Parameter	Symbol	Values			Unit	Note or condition
		Min.	Typ.	Max.		
ENP output voltage level (High)	$V_{ENP\_H}$	7.9	10.0	13.0	V	To on/off bus voltage sensing resistor ladder <b>1.</b> $V_{VCCP} > 9\text{ V}$ <b>2.</b> $R_{load} = 2.5\text{ k}\Omega$
ENP source current	$I_{ENPsrc}$	3.7	6.0	8.4	mA	$V_{ENP} = 5\text{ V}$ , $V_{VCCP} = 7.6\text{ V to }32\text{ V}$

#### 4.4.7 Power switch

**Table 18** Electrical characteristics of power switch

Parameter	Symbol	Values			Unit	Note or condition
		Min.	Typ.	Max.		
DRAIN to CS breakdown voltage (ICE18xx)	$V_{(BR)DSS}$	800	–	–	V	$T_J = 25\text{ }^\circ\text{C}$
DRAIN to CS breakdown voltage (ICE19xx)	$V_{(BR)DSS}$	950	–	–	V	$T_J = 25\text{ }^\circ\text{C}$
DRAIN leakage current	$I_{DSS}$	–	–	1	$\mu\text{A}$	$V_{DRAIN} = 800\text{ V}$ , $T_J = 25\text{ }^\circ\text{C}$
DRAIN leakage current	$I_{DSS}$	–	10	–	$\mu\text{A}$	<sup>1)</sup> $V_{DRAIN} = 800\text{ V}$ , $T_J = 150\text{ }^\circ\text{C}$
DRAIN to CS on-resistance (ICE183xx)	$R_{DS(on)}$	–	1.92	2.18	$\Omega$	$T_J = 25\text{ }^\circ\text{C}$ , $I_D = 1.4\text{ A}$
DRAIN to CS on-resistance (ICE183xx)	$R_{DS(on)}$	–	3.67	–	$\Omega$	$T_J = 125\text{ }^\circ\text{C}$ , $I_D = 1.4\text{ A}$
DRAIN to CS on-resistance (ICE184xx)	$R_{DS(on)}$	–	0.70	0.84	$\Omega$	$T_J = 25\text{ }^\circ\text{C}$ , $I_D = 1.6\text{ A}$
DRAIN to CS on-resistance (ICE184xx)	$R_{DS(on)}$	–	1.48	–	$\Omega$	$T_J = 125\text{ }^\circ\text{C}$ , $I_D = 1.6\text{ A}$
DRAIN to CS on-resistance (ICE186xx)	$R_{DS(on)}$	–	0.39	0.48	$\Omega$	$T_J = 25\text{ }^\circ\text{C}$ , $I_D = 2.0\text{ A}$
DRAIN to CS on-resistance (ICE186xx)	$R_{DS(on)}$	–	0.80	–	$\Omega$	$T_J = 125\text{ }^\circ\text{C}$ , $I_D = 2.0\text{ A}$
DRAIN to CS on-resistance (ICE193xx)	$R_{DS(on)}$	–	2.07	2.53	$\Omega$	$T_J = 25\text{ }^\circ\text{C}$ , $I_D = 1.4\text{ A}$
DRAIN to CS on-resistance (ICE193xx)	$R_{DS(on)}$	–	3.91	–	$\Omega$	$T_J = 125\text{ }^\circ\text{C}$ , $I_D = 1.4\text{ A}$

**(table continues...)**

**Table 18** (continued) Electrical characteristics of power switch

Parameter	Symbol	Values			Unit	Note or condition
		Min.	Typ.	Max.		
Effective output capacitance, energy related (ICE183xx)	$C_{oer}$	–	7	–	pF	1), $V_{DRAIN} = 0\text{ V to }500\text{ V}$
Effective output capacitance, energy related (ICE184xx)	$C_{oer}$	–	12	–	pF	1), $V_{DRAIN} = 0\text{ V to }500\text{ V}$
Effective output capacitance, energy related (ICE186xx)	$C_{oer}$	–	20	–	pF	1), $V_{DRAIN} = 0\text{ V to }500\text{ V}$
Effective output capacitance, energy related (ICE193xx)	$C_{oer}$	–	8	–	pF	1), $V_{DRAIN} = 0\text{ V to }400\text{ V}$
Minimum on-time in closed loop	$t_{ONmin\_CL}$	302	336	370	ns	1)
Maximum on-time in closed loop	$t_{OnMax\_CL}$	31.5	35.0	38.5	μs	1)

1) Not subject to production test - verified by design/characterization

#### 4.4.8 Power supply secondary (VCCS pin)

**Table 19** Electrical characteristics of power supply (VCCS pin)

Parameter	Symbol	Values			Unit	Note or condition
		Min.	Typ.	Max.		
VCCS turn-on threshold	$V_{VCCS_{on}}$	–	–	5.7	V	–
VCCS HW reset hysteresis below turn-on threshold	$V_{VCCS_{res}}$	350	–	1050	mV	–
VCCS undervoltage protection threshold	$V_{VCCS\_UVP}$	6.6	7.0	7.4	V	1)
VCCS undervoltage protection blanking time	$t_{VCCS\_UVP\_B}$	40	–	–	μs	1)
VCCS overvoltage protection threshold	$V_{VCCS\_OVP}$	14.6	15.5	–	V	1)
VCCS overvoltage protection blanking time	$t_{VCCS\_OVP\_B}$	40	–	–	μs	1), 1 V overdrive

**(table continues...)**

4 Characteristics

**Table 19** (continued) Electrical characteristics of power supply (VCCS pin)

Parameter	Symbol	Values			Unit	Note or condition
		Min.	Typ.	Max.		
VCCS supply current in normal mode without gate drive	$I_{VCCSnom}$	–	4.3	–	mA	1)
VCCS supply current during stand-by mode	$I_{VCCSstdby}$	–	360	600	μA	During non-switching time, $T_J < 50\text{ °C}$
VCCS supply current during protection mode	$I_{VCCSoff}$	–	4.3	–	mA	Protection mode entered

1) Not subject to production test - verified by design/characterization

#### 4.4.9 Feedback (FB pin)

**Table 20** Electrical characteristics of FB pin

Parameter	Symbol	Values			Unit	Note or condition
		Min.	Typ.	Max.		
FB leakage current	$I_{FBLK}$	–	–	500	nA	$1.0\text{ V} < V_{FB} < 2.4\text{ V}$
FB reference voltage	$V_{FBref}$	1.176	1.200	1.224	V	–
FB startup voltage	$V_{FBstart}$	–	1.14	–	V	1)
FB overvoltage protection threshold	$V_{FBOVP}$	1.41	1.50	1.59	V	1), 2)
FB overvoltage protection filter time	$t_{FBOVPfil}$	50	–	–	μs	1), 2)

1) Not subject to production test - verified by design/characterization

2) Activated only for corresponding product versions, see [Chapter 3.5.2](#)

#### 4.4.10 Multi-mode and error amplifier output (EA pin)

**Table 21** Electrical characteristics of multi-mode and EA pin

Parameter	Symbol	Values			Unit	Note or condition
		Min.	Typ.	Max.		
EA voltage maximum clamp	$V_{EA\_maxclamp}$	2.2	2.3	2.4	V	–
EA voltage for maximum pulse width	$V_{PWM\_hclamp}$	2.0	2.1	2.2	V	–
EA voltage offset for PWM generation	$V_{PWM\_lclamp}$	0.35	0.40	0.45	V	–

(table continues...)

**Table 21** (continued) Electrical characteristics of multi-mode and EA pin

Parameter	Symbol	Values			Unit	Note or condition
		Min.	Typ.	Max.		
Update interval for target valley	$t_{\text{valleyupdate}}$	45.6	48.0	50.4	ms	1)
Minimum valley for high-line	$N_{\text{valley\_min\_highline}}$	–	2)	–	–	1), Applies if $I_{\text{ZCDS\_clamp}} > I_{\text{ZCDS\_mid}}$
Minimum valley for low-line	$N_{\text{valley\_min\_lowline}}$	–	2)	–	–	1), Applies if $I_{\text{ZCDS\_clamp}} < I_{\text{ZCDS\_mid}} - \Delta I_{\text{ZCDS\_mid}}$
Maximum valley for high-line	$N_{\text{valley\_max\_highline}}$	–	2)	–	–	1), Applies if $I_{\text{ZCDS\_clamp}} > I_{\text{ZCDS\_mid}}$
Maximum valley for low-line	$N_{\text{valley\_max\_lowline}}$	–	2)	–	–	1), Applies if $I_{\text{ZCDS\_clamp}} < I_{\text{ZCDS\_mid}} - \Delta I_{\text{ZCDS\_mid}}$
EA voltage for immediate minimum target valley	$V_{\text{EA\_R}}$	1.72	1.80	1.88	V	–
EA voltage for valley decrease	$V_{\text{EA\_HLC}}$	1.15	1.20	1.25	V	1)
EA voltage for valley increase	$V_{\text{EA\_LHC}}$	0.95	1.00	1.05	V	1)
DCM minimum switching frequency	$f_{\text{sw\_min}}$	24	25	26	kHz	1)
CCM fixed maximum period	$t_{\text{CCMperiod}}$	36	40	44	μs	1)
EA voltage skip threshold tolerance	$\Delta V_{\text{EA\_skip}}$	-10	–	10	%	2)
EA voltage skip threshold	$V_{\text{EA\_skip}}$	–	0.50	–	V	–
EA hysteretic mode entry threshold tolerance	$\Delta V_{\text{EA\_EHM}}$	-7	–	7	%	1), 2)
Hysteretic operation entry blanking time	$t_{\text{HM}}$	18	20	22	ms	1)
EA voltage hysteretic mode on threshold tolerance	$\Delta V_{\text{EA\_HMon}}$	-9	–	9	%	2)
EA voltage hysteretic mode off threshold tolerance	$\Delta V_{\text{EA\_HMOff}}$	-7	–	7	%	2)
EA voltage for pulses during hysteretic mode tolerance	$\Delta V_{\text{EA\_PWM\_HM}}$	-7	–	7	%	2)

(table continues...)

**Table 21** (continued) Electrical characteristics of multi-mode and EA pin

Parameter	Symbol	Values			Unit	Note or condition
		Min.	Typ.	Max.		
Target valley during hysteretic mode	$N_{\text{valley\_HM}}$	–	$N_{\text{valley\_max}}$	–	–	<sup>1)</sup> , Hysteretic mode operation
Wakeup time in hysteretic operation	$t_{\text{wkHM}}$	–	–	80	μs	<sup>1)</sup> , From EA voltage crossing $V_{\text{EA\_HMon}}$ until primary switch turn-on
EA voltage hysteretic mode exit threshold	$V_{\text{EA\_LHM}}$	1.53	1.60	1.67	V	–
EA open-loop threshold	$V_{\text{EA\_OLP}}$	–	$V_{\text{EA\_maxclamp}}$	–	V	–
EA open-loop protection blanking time	$t_{\text{EA\_OLP\_B}}$	20	–	–	ms	<sup>1)</sup>
Maximum switching frequency limitation	$f_{\text{sw\_max}}$	–	–	150	kHz	<sup>1)</sup>

1) Not subject to production test - verified by design/characterization

2) Configurable, see [Chapter 3.5.2](#)

#### 4.4.11 Jitter function

**Table 22** Electrical characteristics of jitter function

Parameter	Symbol	Values			Unit	Note or condition
		Min.	Typ.	Max.		
Jitter repetition frequency	$f_{\text{JITper}}$	3.6	4.0	4.4	kHz	<sup>1)</sup> , Normal mode, $f_{\text{sw}} = 64$ kHz
Jitter frequency amplitude	$\Delta f_{\text{JITamp}}$	3.6	4.0	4.4	%	<sup>1)</sup> , Normal mode

1) Not subject to production test - verified by design/characterization

#### 4.4.12 Zero-crossing detection secondary (ZCDS pin)

**Table 23** Electrical characteristics of ZCDS pin

Parameter	Symbol	Values			Unit	Note or condition
		Min.	Typ.	Max.		
ZCDS clamped voltage level	$V_{\text{ZCDSclamp}}$	–	$V_{\text{VCCS}}$	–	V	$V_{\text{VCCS}} = 12$ V
ZCDS line voltage threshold for valley selection and ZVS enabling	$I_{\text{ZCDS\_mid}}$	1.79	1.99	2.19	mA	<sup>1)</sup> , $N_{\text{MAIN}} / N_{\text{SEC}} = 8$ , $R_{\text{ZCDS}} = 15$ kΩ

(table continues...)

**Table 23** (continued) Electrical characteristics of ZCDS pin

Parameter	Symbol	Values			Unit	Note or condition
		Min.	Typ.	Max.		
ZCDS line voltage hysteresis for valley selection and ZVS enabling	$\Delta I_{ZCDS\_mid}$	242	269	296	$\mu A$	<sup>1)</sup> , $N_{MAIN} / N_{SEC} = 8$ , $R_{ZCDS} = 15 \text{ k}\Omega$
ZCDS line voltage blanking time for valley selection and ZVS enabling	$t_{ZCDS\_mid}$	14.4	16.0	17.6	ms	<sup>1)</sup>
ZCDS SR turn-on threshold	$V_{NSN}$	75	100	125	mV	Falling edge
ZCDS SR turn-on propagation delay	$t_{SRONdel}$	–	100	130	ns	<sup>1)</sup> , From $V_{ZCDS}$ crossing $V_{NSN}$ to GDSR reaching 2 V
ZCDS SR slow turn-off threshold	$V_{ZCDS\_SROFFslow}$	-13	-4	0	mV	Rising slope
ZCDS SR slow turn-off propagation delay	$t_{SROFFslow\_Delay}$	–	300	350	ns	<sup>1)</sup> , From $V_{ZCDS}$ to GDSR reaching 2 V

<sup>1)</sup> Not subject to production test - verified by design/characterization

#### 4.4.13 SR gate driver (GDSR pin)

**Table 24** Electrical characteristics of GDSR pin

Parameter	Symbol	Values			Unit	Note or condition
		Min.	Typ.	Max.		
GDSR pin clamped gate driver voltage	$V_{GDSRclmp}$	9	10	11	V	$V_{VCCS} = 12 \text{ V}$
GDSR pin gate drive voltage at low VCCS	$V_{GDSRlow}$	8.5	–	–	V	$V_{VCCS} = 10 \text{ V}$
Rise time (20% to 80%) of SR gate driver output for demagnetization period	$t_{GDSR\_demag\_rise}$	–	11	80	ns	<sup>1)</sup> , $C_{GDSR} = 3 \text{ nF}$ , $V_{VCCS} = 12 \text{ V}$
Fall time (80% to 20%) of SR gate driver output for demagnetization period	$t_{GDSR\_demag\_fall}$	–	25	50	ns	<sup>1)</sup> , $C_{GDSR} = 3 \text{ nF}$ , $V_{VCCS} = 12 \text{ V}$
Rise time (20% to 80%) of SR gate driver output for ZVS pulse current injection	$t_{GDSR\_zvs\_rise}$	–	26	90	ns	<sup>1)</sup> , $I_{ZCDS} > I_{ZCDS\_mid}$ , $C_{GDSR} = 3 \text{ nF}$ , $V_{VCCS} = 12 \text{ V}$

(table continues...)

4 Characteristics

**Table 24** (continued) Electrical characteristics of GDSR pin

Parameter	Symbol	Values			Unit	Note or condition
		Min.	Typ.	Max.		
Fall time (80% to 20%) of SR gate driver output for ZVS pulse current injection	$t_{\text{GDSR\_zvs\_fall}}$	–	33	70	ns	<sup>1)</sup> , $I_{\text{ZCDS}} > I_{\text{ZCDS\_mid}}$ , $C_{\text{GDSR}} = 3 \text{ nF}$ , $V_{\text{VCCS}} = 12 \text{ V}$
Minimum GDSR on-time	$t_{\text{on\_GDSR}}$	567	630	693	ns	<sup>1)</sup>

<sup>1)</sup> Not subject to production test - verified by design/characterization

#### 4.4.14 Secondary side configuration (CONF0 and CONF1 pins)

**Table 25** Electrical characteristics of CONF0 and CONF1 pins

Parameter	Symbol	Values			Unit	Note or condition
		Min.	Typ.	Max.		
Sourcing sense current	$I_{\text{CONFx}}$	42.5	50	57.5	μA	–

#### 4.4.15 Primary overtemperature sensing

**Table 26** Electrical characteristics of primary overtemperature sensing

Parameter	Symbol	Values			Unit	Note or condition
		Min.	Typ.	Max.		
Overtemperature threshold	$T_{\text{JPOTP}}$	129	140	150	°C	<sup>1)</sup>
Overtemperature reset hysteresis	$T_{\text{JPOTP\_hys}}$	–	40	–	°C	<sup>1)</sup>
Overtemperature blanking time	$t_{\text{JPOTP}}$	–	48	–	ms	<sup>1)</sup>

<sup>1)</sup> Not subject to production test - verified by design/characterization

#### 4.4.16 Common mode transient immunity (CMTI)

**Table 27** Electrical characteristics for common mode transient immunity

Parameter	Symbol	Values			Unit	Note or condition
		Min.	Typ.	Max.		
Common mode transient immunity	CMTI	50	–	–	V/ns	According to DIN V VDE V0884-17, static and dynamic test

### 4.4.17 Isolation specifications

**Table 28** Isolation specifications

Parameter	Symbol	Value	Unit	Note or condition
External creepage	CRP	> 8	mm	Shortest distance over package surface from any input pin to any output pin according to IEC 60664-17
External clearance	CLR	> 8	mm	Shortest distance in air from any input pin to any output pin according to IEC 60664-1
Comparative tracking index	CTI	> 400	V	According to DIN EN 60112 (VDE 0303-11)
Material group	–	II	–	According to IEC 60112
Pollution degree	–	II	–	According to IEC 60664-1
Overvoltage category (for reinforced isolation)	–	I - IV	–	Rated mains voltage $\leq 150 V_{RMS}$
	–	I - IV	–	Rated mains voltage $\leq 300 V_{RMS}$
	–	I - III	–	Rated mains voltage $\leq 600 V_{RMS}$
Climatic category	–	40/125/2 1	–	

#### Input-to-output isolation according to UL1577

Input-to-output isolation voltage	$V_{ISO}$	5700	$V_{RMS}$	$V_{TEST} = V_{ISO}$ for $t = 60$ s (qualification); $V_{TEST} = 1.2 \times V_{ISO}$ for $t = 1$ s (100 % productive tests)
-----------------------------------	-----------	------	-----------	--

#### Input-to-output isolation according to IEC 60747-17 (VDE 0884-17)

Maximum impulse voltage	$V_{IMP}$	8000	$V_{pk}$	According to IEC 60664-1
Maximum rated transient isolation voltage	$V_{IOTM}$	8000	$V_{pk}$	$V_{TEST} = V_{IOTM}$ for $t_{ini} = 60$ s (type test and sample test) $V_{TEST} = 1.2 \times V_{IOTM}$ for $t_{ini} = 1$ s (routine test)
Maximum rated repetitive peak isolation voltage (ICE18xxx)	$V_{IORM}$	800	$V_{pk}$	According to time dependent dielectric breakdown (TDDB) test for reinforced isolation
Maximum rated repetitive peak isolation voltage (ICE19xxx)	$V_{IORM}$	950	$V_{pk}$	According to time dependent dielectric breakdown (TDDB) test for reinforced isolation
Apparent charge	$q_{PD}$	< 5	pC	Method (b1) $V_{ini,b1} = 1.2 \times V_{IOTM}$ (routine test) $V_{ini,b1} = V_{IOTM}$ for $t_{ini} = 1$ s (type test preconditioning) $V_{PD(m)} = 1.875 \times V_{IORM}$ for $t_m = 1$ s Method (a) (type test, subgroup 1 final measurements) $V_{ini,a} = V_{IOTM}$ for $t_{ini} = 60$ s $V_{PD(m)} = 1.6 \times V_{IORM}$ for $t_m = 10$ s Method (a) (type test, subgroup 2, 3 final measurements) $V_{ini,a} = V_{IOTM}$ for $t_{ini} = 60$ s $V_{PD(m)} = 1.2 \times V_{IORM}$ for $t_m = 10$ s

(table continues...)

**Table 28** (continued) Isolation specifications

Parameter	Symbol	Value	Unit	Note or condition
Maximum surge isolation voltage	$V_{IOSM}$	11000	$V_{pk}$	$V_{TEST} = 11 \text{ kV}_{pk} \geq 1.3 \times V_{IMP}$ for reinforced isolation according IEC 60747-17
Isolation resistance	$R_{IO}$	$> 10^{12}$	$\Omega$	$V_{IO} = 500 \text{ V}_{dc}$ for $t = 60 \text{ s}$ , $T_A = 25 \text{ }^\circ\text{C}$
		$> 10^{11}$	$\Omega$	$V_{IO} = 500 \text{ V}_{dc}$ for $t = 60 \text{ s}$ , $T_A = 125 \text{ }^\circ\text{C}$
		$> 10^9$	$\Omega$	$V_{IO} = 500 \text{ V}_{dc}$ for $t = 60 \text{ s}$ , $T_S = T_A = 150 \text{ }^\circ\text{C}$
Isolation capacitance	$C_{IO}$	$< 2$	pF	$f = 1 \text{ MHz}$

#### 4.4.18 Safety supply power

**Table 29 Reinforced isolation safety-limiting values as outlined in IEC 60747-17 (VDE 0884-17)**

Parameter	Side	Value	Unit	Note or condition
Primary side power switch safe DC current (ICE193xM)	Power switch chip	0.46	A	Average current of PWM switching cycle, $T_J = 140\text{ °C}$
Primary side power switch safe DC current (ICE183xM)	Power switch chip	0.50	A	Average current of PWM switching cycle, $T_J = 140\text{ °C}$
Primary side power switch safe DC current (ICE184xM)	Power switch chip	0.82	A	Average current of PWM switching cycle, $T_J = 140\text{ °C}$
Primary side power switch safe DC current (ICE186xM)	Power switch chip	1.10	A	Average current of PWM switching cycle, $T_J = 140\text{ °C}$
Safety supply currents	Primary chip	12	mA	$R_{thja(max)} = 66,9\text{ K/W}$ , $V_{CCP} = 20\text{ V}$ , $T_A = 25\text{ °C}$ , $T_J = 125\text{ °C}$ (Overtemperature protected)
	Secondary chip	20	mA	$R_{thja(max)} = 66,9\text{ K/W}$ , $V_{CCS} = 12\text{ V}$ , $T_A = 25\text{ °C}$ , $T_J = 125\text{ °C}$
Safety power supply	Primary chip	0.24	W	$R_{thja(max)} = 66,9\text{ K/W}$ , $T_A = 25\text{ °C}$ , $T_J = 125\text{ °C}$ (Overtemperature protected)
	Power switch chip	1.27	W	$R_{thja(max)} = 66,9\text{ K/W}$ , $T_A = 25\text{ °C}$ , $T_J = 140\text{ °C}$
	Secondary chip	0.24	W	$R_{thja(max)} = 66,9\text{ K/W}$ , $T_A = 25\text{ °C}$ , $T_J = 125\text{ °C}$

5 Package information

5.1 Outline dimensions and footprint

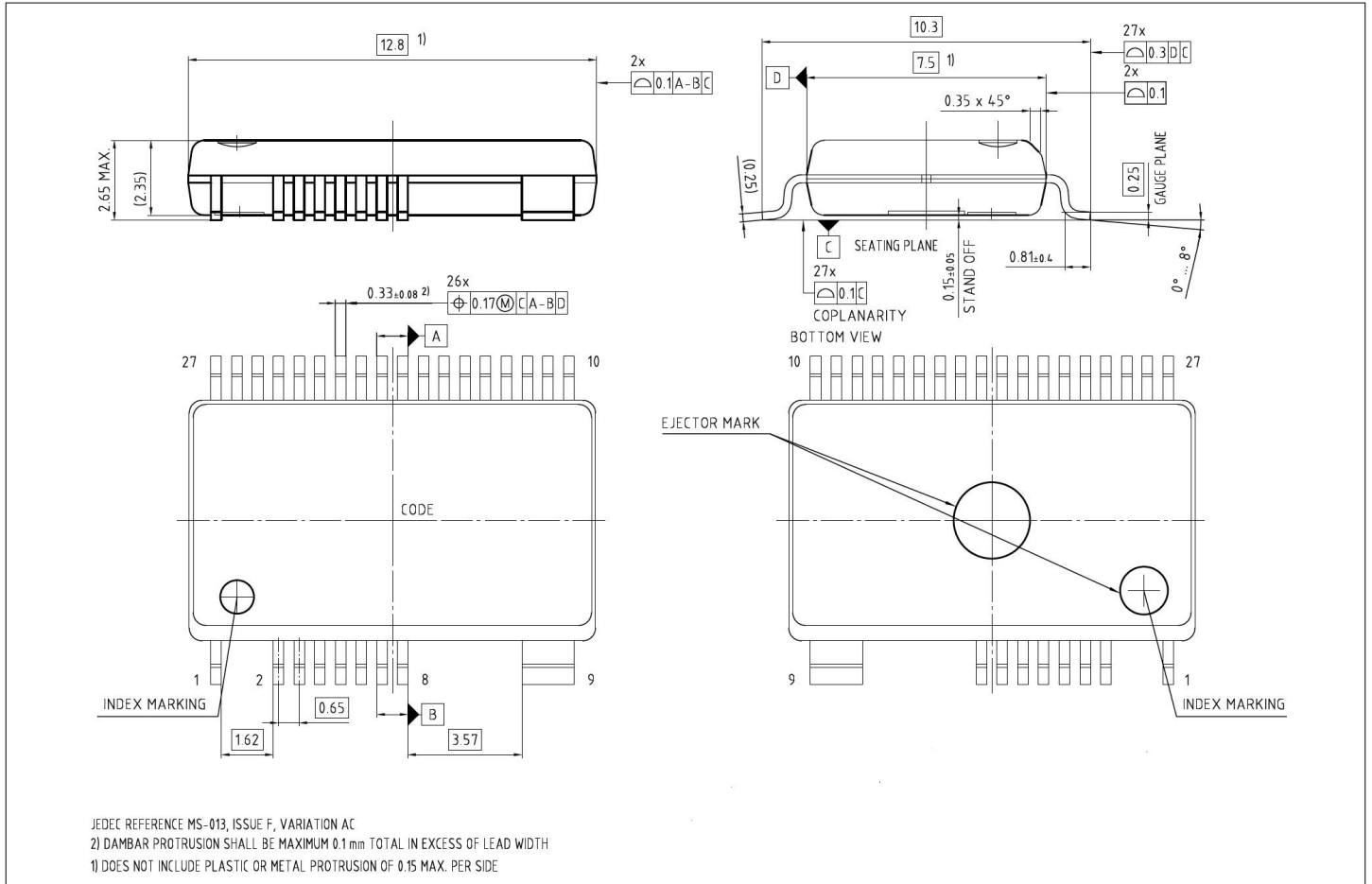

Figure 9 Outline dimensions PG-DSO-27-1

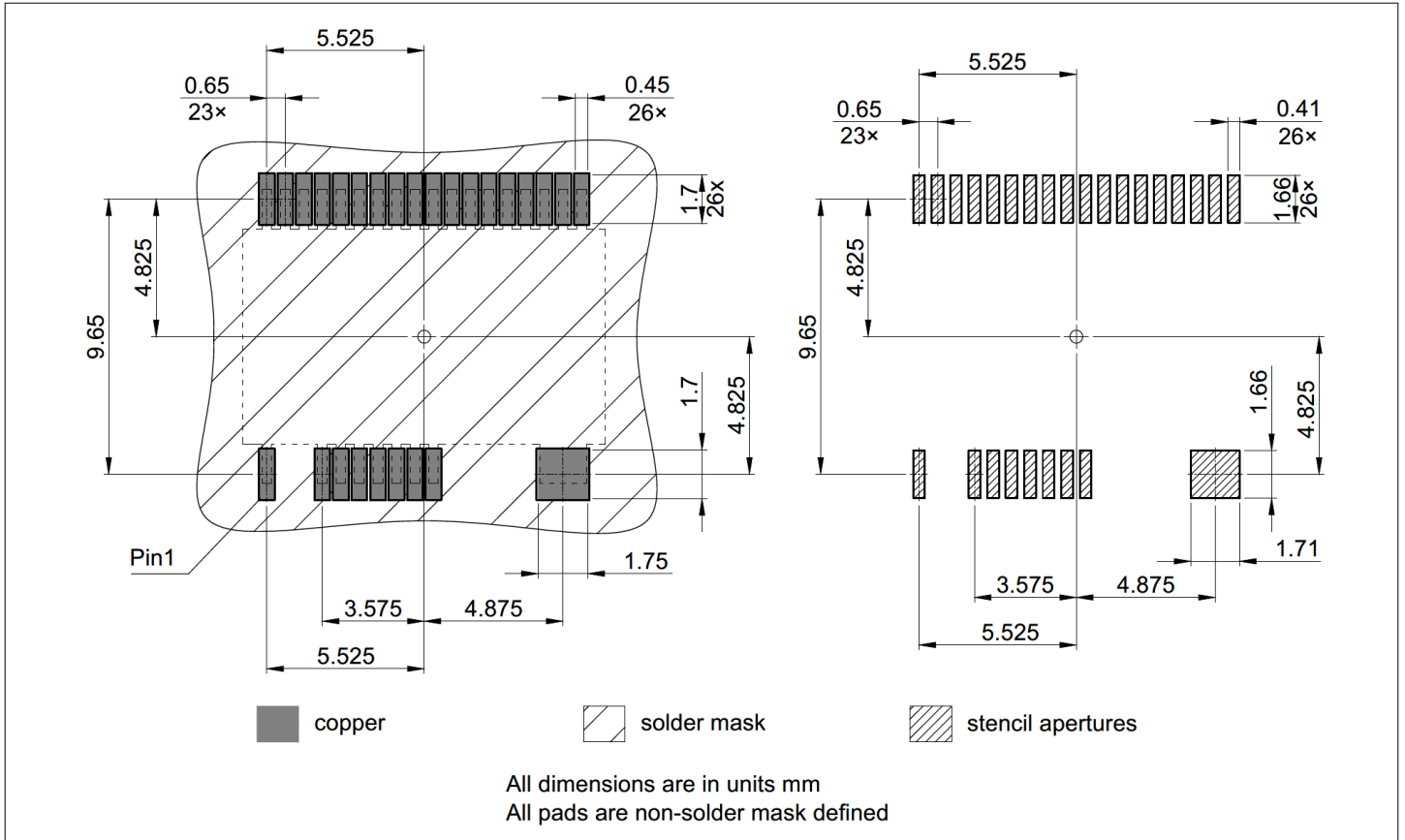

Figure 10 Footprint

## 5.2 Marking

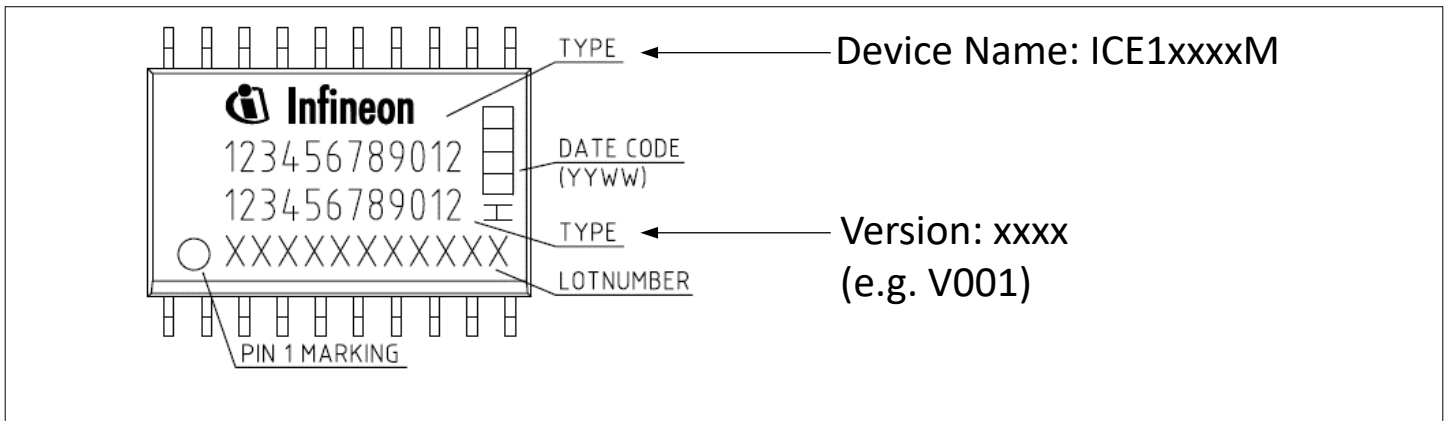

Figure 11

### 5.3 Green product (RoHS compliant)

**Table 30 Green product and RoHS compliant**

<b>Package compliance</b>	<b>Description</b>
Green product	For minimum environmental impact and compliance with government regulations, the package of the device fulfills the requirements of a green product. Green products are RoHS-compliant (Pb-free finish on leads and suitable for Pb-free soldering according to IPC/JEDEC J-STD-020).
RoHS	The package of the device is RoHS-compliant.

## 6 Part ordering information

**Table 31** Feature code table

Features	LM-V001	LM-V101
Parameter setting table	Table 7	Table 8

Part number	Ordering code	Package	Power FET	$R_{DS(on)}(max)^1$
ICE183LM-V001	SP006172811	PG-DSO-27-1	800 V CoolMOS™ P7	2.18 Ω
ICE193LM-V001	SP006172852	PG-DSO-27-1	950 V CoolMOS™ P7	2.53 Ω
ICE184LM-V001	SP006172799	PG-DSO-27-1	800 V CoolMOS™ P7	0.84 Ω
ICE186LM-V001	SP006172839	PG-DSO-27-1	800 V CoolMOS™ P7	0.48 Ω
ICE186LM-V101	SP006138229	PG-DSO-27-1	800 V CoolMOS™ P7	0.48 Ω

<sup>1)</sup> at  $T_J = 25\text{ °C}$

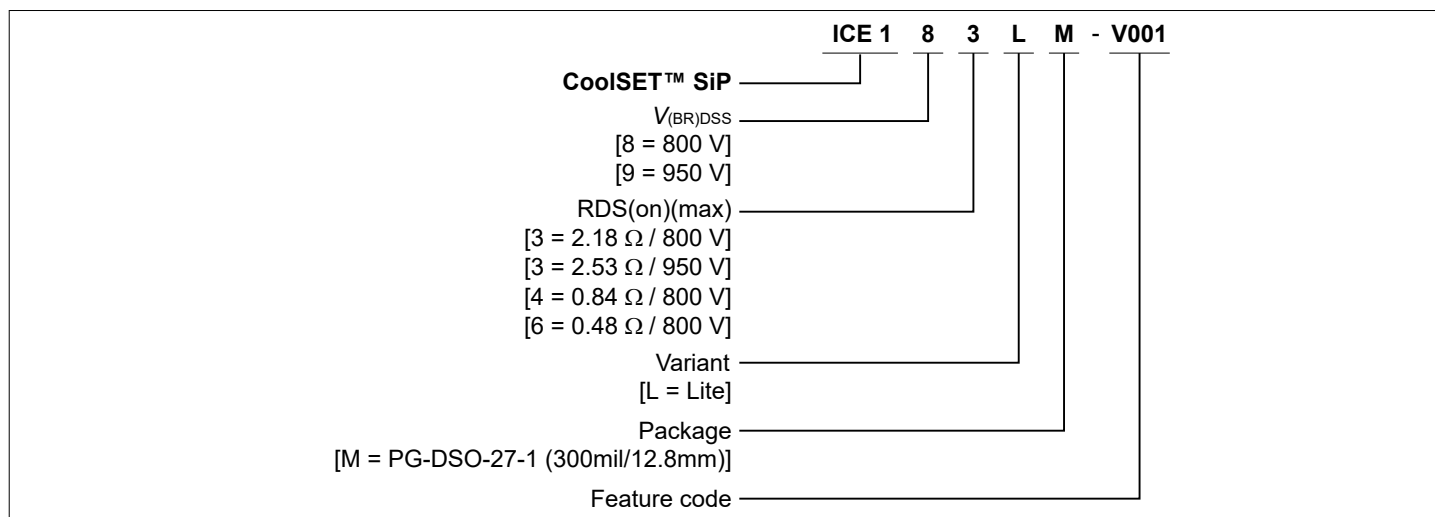

**Figure 12** Part ordering information

## 7 Revision history

<b>Document version</b>	<b>Date of release</b>	<b>Description of changes</b>
Rev 1.0	2025-11-26	Initial release
Rev 1.1	2026-01-13	<ul style="list-style-type: none"><li>• Updated protection feature table 3 on page 18</li><li>• Updated part ordering information on page 43</li></ul>

## Trademarks

All referenced product or service names and trademarks are the property of their respective owners.

**Edition 2026-01-13**

**Published by**

**Infineon Technologies AG**

**81726 Munich, Germany**

**© 2026 Infineon Technologies AG**

**All Rights Reserved.**

**Do you have a question about any aspect of this document?**

**Email: [erratum@infineon.com](mailto:erratum@infineon.com)**

**Document reference**

**IFX-htk1739882223712**

## Important notice

The information given in this document shall in no event be regarded as a guarantee of conditions or characteristics ("Beschaffheitsgarantie").

With respect to any examples, hints or any typical values stated herein and/or any information regarding the application of the product, Infineon Technologies hereby disclaims any and all warranties and liabilities of any kind, including without limitation warranties of non-infringement of intellectual property rights of any third party.

In addition, any information given in this document is subject to customer's compliance with its obligations stated in this document and any applicable legal requirements, norms and standards concerning customer's products and any use of the product of Infineon Technologies in customer's applications.

The data contained in this document is exclusively intended for technically trained staff. It is the responsibility of customer's technical departments to evaluate the suitability of the product for the intended application and the completeness of the product information given in this document with respect to such application.

## Warnings

Due to technical requirements products may contain dangerous substances. For information on the types in question please contact your nearest Infineon Technologies office.

Except as otherwise explicitly approved by Infineon Technologies in a written document signed by authorized representatives of Infineon Technologies, Infineon Technologies' products may not be used in any applications where a failure of the product or any consequences of the use thereof can reasonably be expected to result in personal injury.