

# 30CNKCQ100

PD-98002A

## Schottky Rectifier High Efficiency Series Surface Mount (SMD-0.5e Ceramic Lid) 100V, 30A

### Features

- Hermetically sealed
- Center tap
- Low forward voltage drops
- High frequency operation
- Guard ring for enhanced ruggedness and long term reliability
- Surface mount
- Light weight
- ESD rating: Class 3B per MIL-STD-750, Method 1020

### Potential Applications

- DC-DC converter
- Protection circuits

### Product Validation

Fully qualified according to MIL-PRF-19500 for space applications

### Description

The 30CNKCQ100 center tap Schottky rectifier has been expressly designed to meet the rigorous requirements of high reliability environments. It is packaged in the hermetic surface mount SMD-0.5e ceramic package. The device's forward voltage drop and reverse leakage current are optimized for the lowest power loss and the highest circuit efficiency for typical high frequency switching power supplies and resonant power converters. Full MIL-PRF-19500 quality conformance testing is available on source control drawings to S quality levels.

### Ordering Information

**Table 1** Ordering options

Part number	Package	Screening Level
30CNKCQ100	SMD-0.5e (Ceramic Lid)	COTS
30CNKCQ100SCS	SMD-0.5e (Ceramic Lid)	S-level

### Product Summary

- $V_{RRM}$ : 100V
- $I_{F(AV)}$ : 30A
- $V_F @ 30A_{pk}, T_J = 125^\circ C$ : 0.95V
- $I_{FSM} @ t_p = 8.3ms \text{ half-sine}$ : 100A



**Table of contents**

**Table of contents**

<b>Features .....</b>	<b>1</b>
<b>Potential Applications.....</b>	<b>1</b>
<b>Product Validation.....</b>	<b>1</b>
<b>Description .....</b>	<b>1</b>
<b>Ordering Information.....</b>	<b>1</b>
<b>Table of contents.....</b>	<b>2</b>
<b>1 Absolute Maximum Ratings .....</b>	<b>3</b>
<b>2 Device Characteristics .....</b>	<b>4</b>
2.1 Electrical Characteristics .....	4
2.2 Thermal-Mechanical Specifications .....	4
<b>3 Electrical Characteristics Curves.....</b>	<b>5</b>
<b>4 Package Outline.....</b>	<b>7</b>
<b>Revision history.....</b>	<b>8</b>

## Absolute Maximum Ratings

# 1 Absolute Maximum Ratings

Table 2 Absolute Maximum Ratings

Symbol	Parameter	Value	Unit
$V_R$	DC reverse voltage (per leg)	100	V
$V_{RWM}$	Working peak reverse voltage (per leg)	100	V
$I_{F(AV)}$	Max. average forward current (per package) <sup>1</sup> - Refer to Fig. 5	30	A
$I_{FSM}$	Max. peak one cycle non-repetitive surge current (per leg) <sup>2</sup>	100	A
$T_J$ $T_{STG}$	Operating Junction and Storage Temperature Range	-65 to 150	°C
	Weight	1.0 (Typical)	g

---

<sup>1</sup> 50% duty cycle @  $T_c = 83^\circ\text{C}$ , square waveform

<sup>2</sup>  $t_p = 8.3$  ms half-sine

## Device Characteristics

## 2 Device Characteristics

### 2.1 Electrical Characteristics

Table 3 Electrical Characteristics

Symbol	Parameter	Max.	Unit	Test Conditions					
V <sub>F</sub>	Forward Voltage Drop (Per Leg) See Fig. 1 <sup>1</sup>	0.95	V	@5.0A	T <sub>J</sub> = -55°C				
		1.18	V	@15A					
		1.43	V	@30A					
				0.77	V	@5.0A	T <sub>J</sub> = 25°C		
				1.03	V	@15A			
				1.27	V	@30A			
						0.65	V	@5.0A	T <sub>J</sub> = 125°C
						0.77	V	@15A	
						0.95	V	@30A	
I <sub>R</sub>	Reverse Leakage Current (Per Leg) See Fig. 2 <sup>1</sup>	0.01	mA	T <sub>J</sub> = 25°C	V <sub>R</sub> = rated V <sub>R</sub>				
		1.19	mA	T <sub>J</sub> = 100°C					
		5.0	mA	T <sub>J</sub> = 125°C					
C <sub>J</sub>	Junction Capacitance (Per Leg)	275	pF	V <sub>R</sub> = 5V <sub>DC</sub> ( 1MHz, 25°C )					
L <sub>S</sub>	Series Inductance (Per Leg)	4.8(Typical)	nH	Measured from center of cathode pad to center of anode pad					

### 2.2 Thermal-Mechanical Specifications

Table 4 Thermal-Mechanical Specifications

Symbol	Parameter	Max.	Unit	Test Conditions
R <sub>θJC</sub>	Thermal Resistance, Junction to Case (Per Leg)	3.5	°C/W	DC operation See Fig. 4
R <sub>θJC</sub>	Thermal Resistance, Junction to Case (Per Package)	1.75	°C/W	DC operation
	Die Size (Typical)	84 x 84	mils	

<sup>1</sup> Pulse Width < 300μs, Duty Cycle < 2%

### 3 Electrical Characteristics Curves

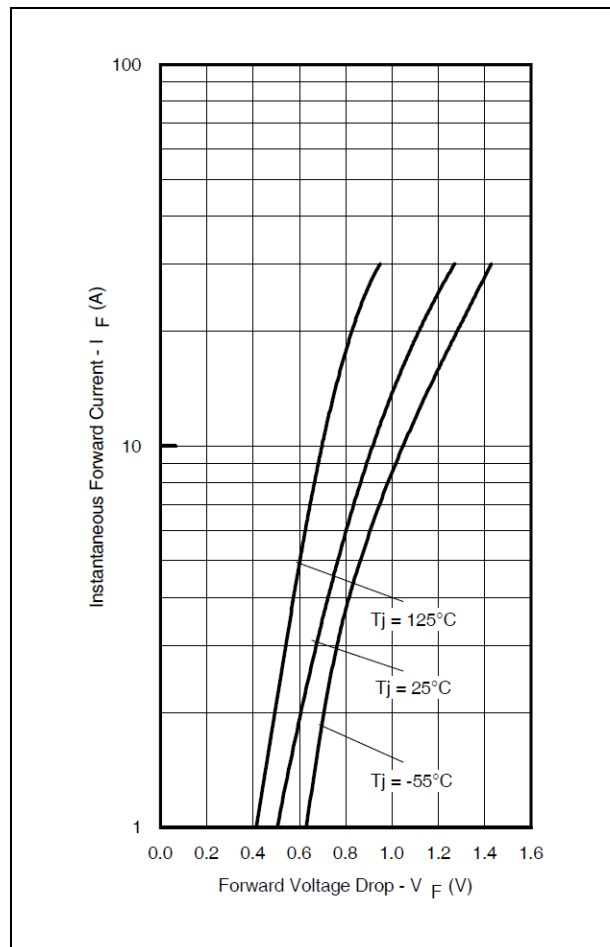

**Figure 1 Maximum Forward Voltage Drop Characteristics (Per Leg)**

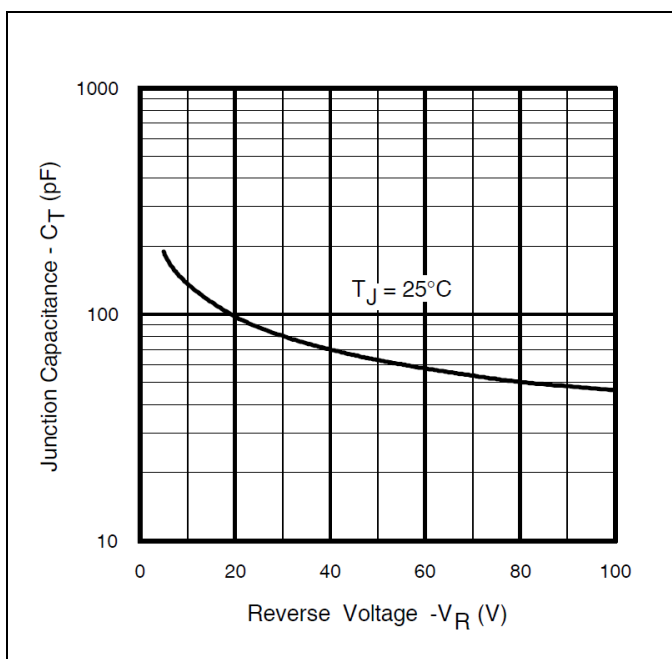

**Figure 2 Typical Values of Reverse Current Vs. Reverse Voltage (Per Leg)**

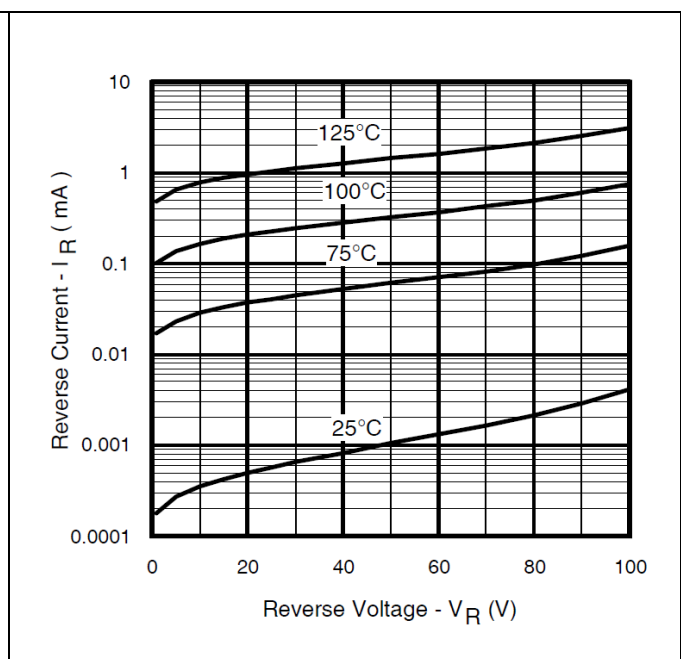

**Figure 3 Typical Junction Capacitance Vs. Reverse Voltage (Per Leg)**

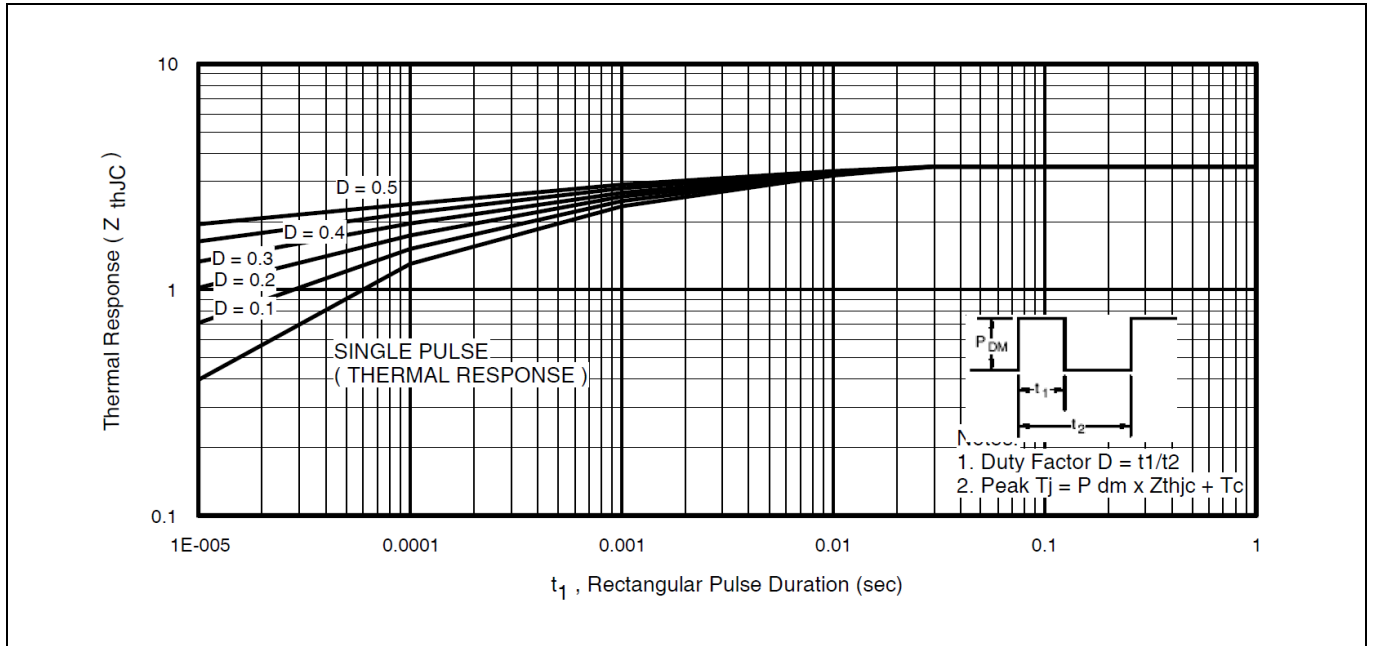

Figure 4 Maximum Thermal Impedance  $Z_{thJC}$  Characteristics (Per Leg)

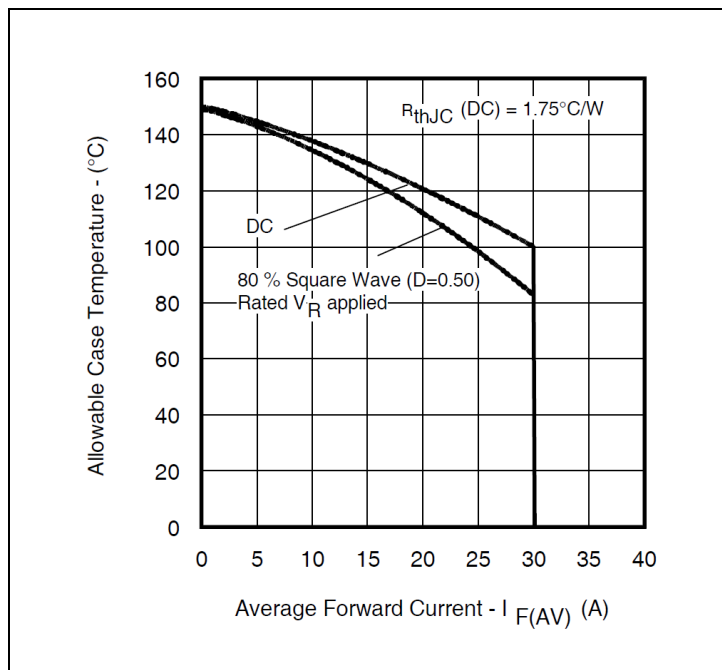

Figure 5 Maximum Allowable Case Temperature Vs. Average Forward Current (Per Package)

# 30CNKCQ100

## Schottky Rectifier High Efficiency Series Surface Mount (SMD-0.5e Ceramic Lid)

### Package Outline

## 4 Package Outline

Note: For the most updated package outline, please see the website: [SMD-0.5e \(Ceramic Lid\)](#)

REV.	DESCRIPTION	ECN	DATE
B	CHANGE PER ECN	1120_09117	5-20-22

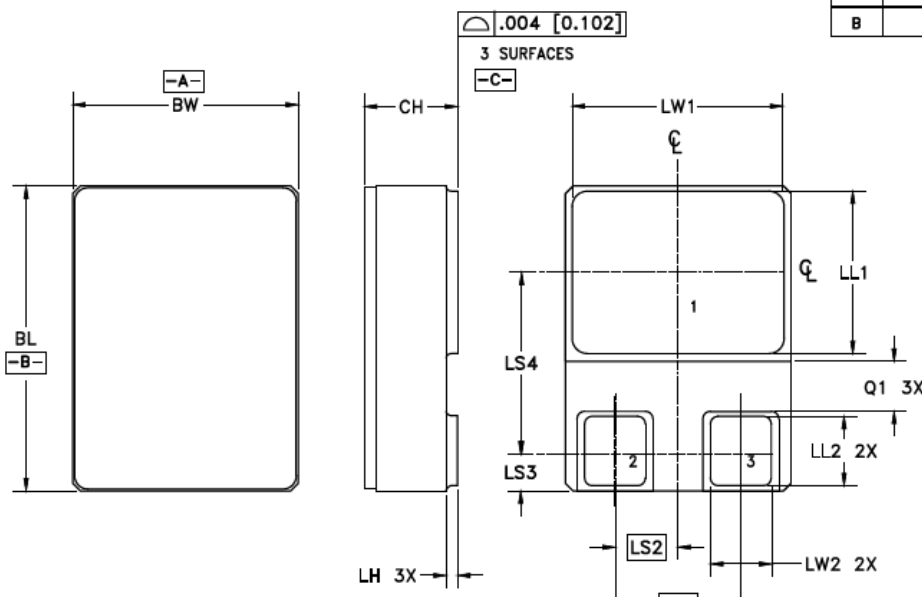

Symbol	Inches		Millimeters	
	Min	Max	Min	Max
BL	0.395	0.405	10.04	10.28
BW	0.291	0.301	7.4	7.64
CH		0.122		3.09
LH	0.008	0.022	0.20	0.55
LW1	0.271	0.281	6.88	7.14
LW2	0.075	0.085	1.91	2.16
LL1	0.208	0.218	5.28	5.54
LL2	0.087	0.097	2.21	2.46
LS1	.165 BSC		4.19 BSC	
LS2	.083 BSC		2.10 BSC	
LS3	.053 BSC		1.35 BSC	
LS4	.234 BSC		5.93 BSC	
Q1	0.06		0.152	
TERM 1	Drain			
TERM 2	Gate			
TERM 3	Source			

NOTES:

- DIMENSIONING & TOLERANCING PER ASME Y14.5M-1994.
- CONTROLLING DIMENSION: INCH.
- DIMENSIONS ARE SHOWN IN INCHES [MILLIMETERS].
- DIMENSION TOLERANCE  $\pm 0.005$ .
- STANDARD FINAL LEAD FINISH IS SOLDER ALLOY 63%Sn 37%Pb.
- DIMENSIONS APPLY BEFORE SOLDER FINISH.

Surface Finish:  $\sqrt{0.004} [0.102]$   
3 SURFACES

Material:  $\text{C} \text{A} \text{M} \text{B} \text{M}$

(ISOLATED BASE)

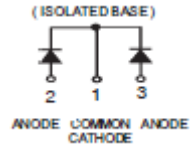

ANODE COMMON ANODE  
CATHODE

TITLE: SMD-0.5e with ceramic lid	
DRAWING NO. D101007G-WEB	REV B

# 30CNKCQ100

## Schottky Rectifier High Efficiency Series Surface Mount (SMD-0.5e Ceramic Lid)

### Revision history

### Revision history

Document version	Date of release	Description of changes
	08/03/2023	Preliminary datasheet with PPD number (PPD-98002)
Rev A	11/02/2023	Final datasheet with PD number

## Trademarks

All referenced product or service names and trademarks are the property of their respective owners.

**Edition 2023-11-02**

### Published by

**International Rectifier HiRel Products,  
Inc.**

**An Infineon Technologies company  
El Segundo, California 90245 USA**

**© 2023 Infineon Technologies AG.  
All Rights Reserved.**

**Do you have a question about this  
document?**

**Email: [erratum@infineon.com](mailto:erratum@infineon.com)**

**Document reference**

## IMPORTANT NOTICE

The information given in this document shall in no event be regarded as a guarantee of conditions or characteristics ("Beschaffenhheitsgarantie").

With respect to any examples, hints or any typical values stated herein and/or any information regarding the application of the product, Infineon Technologies hereby disclaims any and all warranties and liabilities of any kind, including without limitation warranties of non-infringement of intellectual property rights of any third party.

In addition, any information given in this document is subject to customer's compliance with its obligations stated in this document and any applicable legal requirements, norms and standards concerning customer's products and any use of the product of Infineon Technologies in customer's applications.

The data contained in this document is exclusively intended for technically trained staff. It is the responsibility of customer's technical departments to evaluate the suitability of the product for the intended application and the completeness of the product information given in this document with respect to such application.

For further information on the product, technology, delivery terms and conditions and prices please contact your nearest Infineon Technologies office ([www.infineon.com](http://www.infineon.com)).

## WARNINGS

Due to technical requirements components may contain dangerous substances. For information on the types in question please contact your nearest International Rectifier HiRel Products, Inc., an Infineon Technologies company, office.

International Rectifier HiRel Components may only be used in life-support devices or systems with the expressed written approval of International Rectifier HiRel Products, Inc., an Infineon Technologies company, if failure of such components can reasonably be expected to cause the failure of that life-support device or system, or to affect the safety and effectiveness of that device or system.

Technologies, Infineon Technologies' products may not be used in any applications where a failure of the product or any consequences of the use thereof can reasonably be expected to result in personal injury.

Life support devices or systems are intended to be implanted in the human body, or to support and/or maintain and sustain and/or protect human life. If they fail, it is reasonable to assume that the health of the user or other persons may be endangered.