

EiceDRIVER™ 2EDR8259H, 2EDRx259X, 2EDRx258X

Dual-channel isolated gate driver ICs in 300 mil DSO package

EiceDRIVER™ 2EDR8259H, 2EDRx259X, 2EDRx258X is a family of dual-channel isolated gate driver ICs, designed to drive Si and SiC MOSFETs and GaN HEMTs power switches. All products are available in a DSO package with 8 mm input-to-output creepage and provide reinforced isolation by means of on-chip coreless transformer (CT) technology. 2EDRx259X and 2EDRx258X variants in a 14-pin DSO package offer increased channel-to-channel creepage. They are suited for use in applications with higher bus voltage or higher pollution degree and, in general, can ease PCB routing. All versions offer optional shoot-through protection (STP) and dead-time control (DTC) functionality. This allows the operation as dual-channel low-side, dual-channel high-side or half-bridge gate driver with a configurable dead-time. With excellent common-mode transient immunity (CMTI), low part-to-part skew and fast signal propagation, the products are best suited for use in fast-switching power conversion systems.

Features

- 2-channel isolated gate driver for Si and SiC MOSFETs and GaN HEMTs power switches
- 38 ns fast input-to-output propagation with excellent stability (+9/-5 ns)
- 5 A/9 A source/sink capability
- 1.2 V output clamping threshold
- < 2 μs fast UVLO recovery time
- 4 V, 8 V, 12 V and 15 V VDDA/B UVLO options
- > 150 V/ns CMTI
- Available in 16/14-pin 300 mil DSO package

Isolation and safety certificates

- UL1577 with $V_{ISO} = 5700 V_{RMS}$ (certification n. E311313)
- CSA Component acceptance service notice no. 5A
- IEC 60747-17 with $V_{IOTM} = 8000 V_{pk}$, $V_{IORM} = 1767 V_{pk}$, $V_{IOSM} = 11000 V_{pk}$ (certification n. 40055138)
- EN IEC 62368-1 Third edition (certification n. 40055138, appendix 500Z1)
- IEC 62368-1 (certification n. CN67627)
- GB 4943.1-2022 (certification n. CQC23001416209)

Product validation

Fully qualified for industrial applications

Table 1

Portfolio

| Part number | UVLO | EN/DIS | Package |
|-------------|------|--------|--------------|
| 2EDR8259H | 8 V | DIS | DSO16-300mil |
| 2EDR7259X | 4 V | DIS | DSO14-300mil |
| 2EDR8259X | 8 V | DIS | DSO14-300mil |
| 2EDR9259X | 15 V | DIS | DSO14-300mil |
| 2EDR8258X | 8 V | EN | DSO14-300mil |
| 2EDR6258X | 12 V | EN | DSO14-300mil |
| 2EDR9258X | 15 V | EN | DSO14-300mil |

Potential applications

- Server, telecom SMPS
- EV Off-board chargers
- Low-voltage drives and power tools
- Solar micro inverter, solar optimizer
- Industrial power supply (SMPS, Residential UPS)

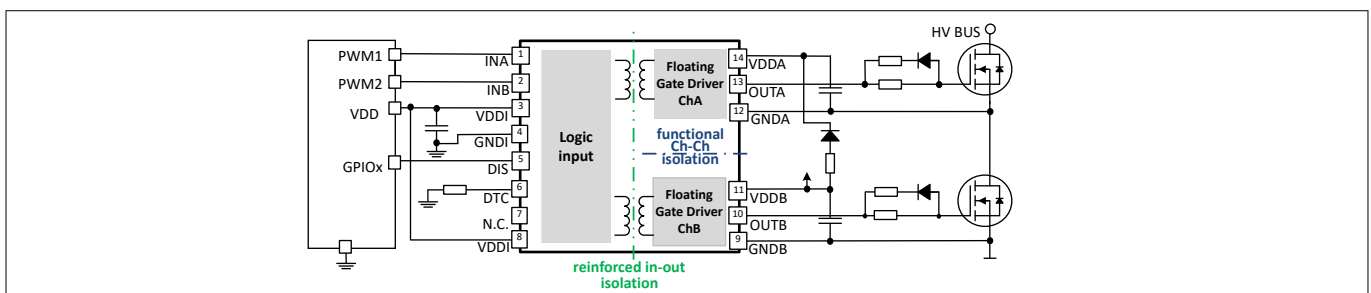

Figure 1 Application diagram

Table of contents

| | | |
|----------|---|----|
| | Table of contents | 2 |
| 1 | Pin configuration and description | 3 |
| 2 | Functional description | 5 |
| 2.1 | Block diagram | 5 |
| 2.2 | Power supply and Undervoltage Lockout (UVLO) | 5 |
| 2.2.1 | Input supply voltage | 5 |
| 2.2.2 | Output supply voltage | 5 |
| 2.3 | Input stage - INA, INB, DISABLE | 6 |
| 2.4 | Shoot-through protection and configurable dead-time - STP/DTC | 8 |
| 2.5 | Gate driver outputs | 9 |
| 2.6 | Fast active output clamping in UVLO conditions | 9 |
| 2.7 | CT communication and input to output data transmission | 9 |
| 3 | Electrical characteristics | 10 |
| 3.1 | Absolute maximum ratings | 10 |
| 3.2 | Thermal characteristics | 11 |
| 3.3 | Operating range | 12 |
| 3.4 | Electrical characteristics | 12 |
| 3.5 | Isolation specifications | 17 |
| 3.5.1 | Safety-limiting values | 19 |
| 4 | Timing diagrams | 20 |
| 5 | Typical characteristics | 23 |
| 6 | Package outline dimensions | 30 |
| 6.1 | Device numbers and markings | 30 |
| 6.2 | Package DSO16-300mil | 30 |
| 6.3 | Package DSO14-300mil | 32 |
| 7 | Revision history | 34 |
| | Disclaimer | 35 |

1 Pin configuration and description

1 Pin configuration and description

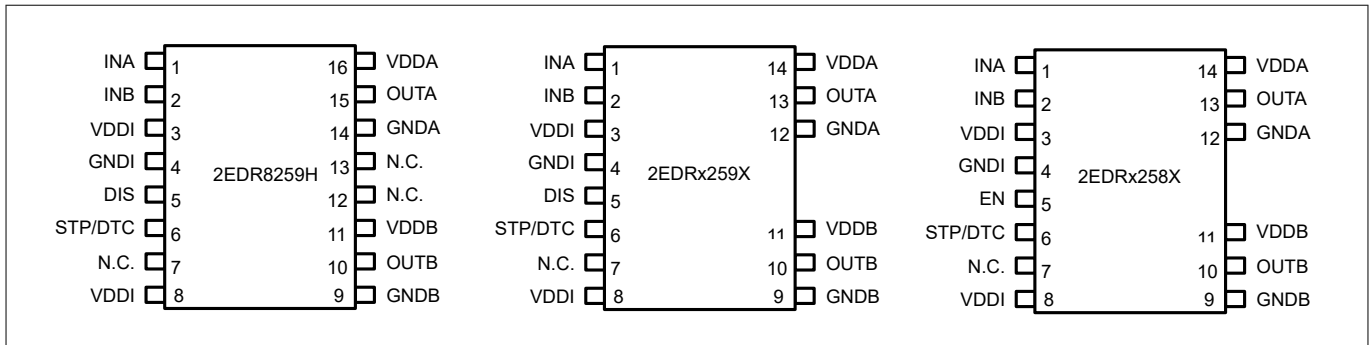

Figure 2 Pin configuration (top side view)

Table 2 Pin description

| Pin 16-pin | Pin 14-pin | Symbol | Description |
|------------|------------|---------|--|
| 1 | 1 | INA | Input signal channel A Logic input with TTL compatible thresholds and internal pull-down resistor |
| 2 | 2 | INB | Input signal channel B Logic input with TTL compatible thresholds and internal pull-down resistor |
| 3,8 | 3,8 | VDDI | Input-side supply voltage (operating range: 3 V to 17 V) |
| 4 | 4 | GNDI | Ground primary-side |
| 5 | 5 | DIS/ EN | Disable input channel A and B (active high) If DIS is low or left open, OUTA/OUTB are controlled by INA/INB DIS high causes OUTA/OUTB low ENABLE input channel A and B (active high) If EN is high, OUTA/OUTB are controlled by INA/INB EN low or left open causes OUTA/OUTB low |
| 6 | 6 | STP/DTC | Shoot-through Protection (STP) and Dead-Time Control (DTC) If STP/DTC is high or left open, OUTA and OUTB can overlap (SPT and DTC disabled). If STP/DTC is connected to GNDI with a resistance R_{DTC} , OUTA and OUTB cannot overlap and a “safe dead-time” can be configured: $t_{dt} [ns] = 10 \times R_{DTC} [k\Omega]$ If STP/DTC is connected to GNDI, OUTA and OUTB cannot overlap (STP only enabled) Connecting capacitors to the DTC pin must be avoided. |
| 7,12,13 | 7 | N.C. | No internal connection |
| 9 | 9 | GNDB | Ground secondary-side channel B |
| 10 | 10 | OUTB | Output secondary-side channel B Low-impedance output with source and sink capability |
| 11 | 11 | VDDB | Supply secondary-side channel B (operating range: UVLO to 20 V) |

(table continues...)

1 Pin configuration and description

Table 2 (continued) **Pin description**

| Pin 16-pin | Pin 14-pin | Symbol | Description |
|-----------------------|-----------------------|---------------|--|
| 14 | 12 | GNDA | Ground secondary-side channel A |
| 15 | 13 | OUTA | Output secondary-side channel A Low-impedance output with source and sink capability |
| 16 | 14 | VDDA | Supply secondary-side channel A (operating range: UVLO to 20 V) |

For package drawing details see [Chapter 6](#).

2 Functional description

2 Functional description

2.1 Block diagram

A simplified functional block diagram for EiceDRIVER™ 2EDR8259H, 2EDRx259X is given in [Figure 3](#).

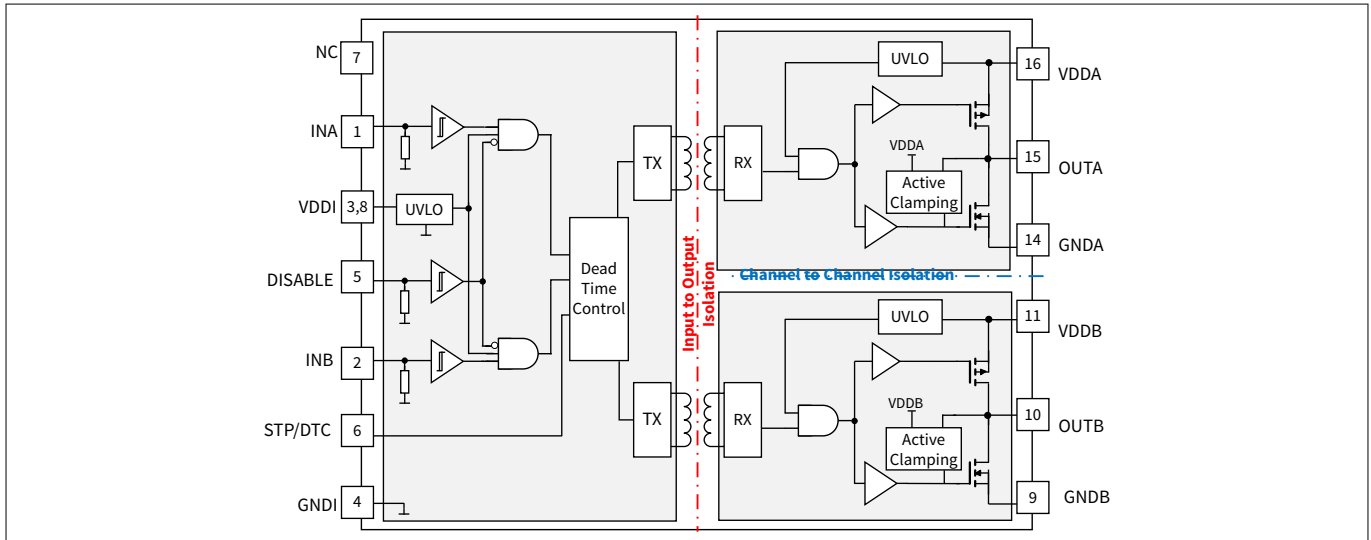

Figure 3 Block diagram

2.2 Power supply and Undervoltage Lockout (UVLO)

Due to the input-to-output and channel-to-channel isolation, three power domains with independent power management are required. Undervoltage Lockout (UVLO) functions for both input and output supplies ensure a defined startup and robust functionality under all operating conditions.

2.2.1 Input supply voltage

The input die is powered via VDDI and supports a wide supply voltage range from 3 V to 17 V. A ceramic bypass capacitor must be placed between VDDI and GNDI in close proximity to the device; a minimum bypass capacitance of 100 nF is recommended.

Power consumption to some extent, depends on switching frequency, as the input signal is converted into a train of repetitive current pulses to drive the coreless transformer. Due to the chosen robust encoding scheme the average repetition rate of these pulses and thus the average supply current depends on the switching frequency, f_{sw} . However, for $f_{sw} < 500$ kHz this effect is very small.

The Undervoltage Lockout function for the input supply V_{DDI} ensures that, as long as V_{DDI} is below UVLO (e.g. in startup), no data is transferred to the output side and the gate driver output is held low (safety Lock-down at startup). When V_{DDI} exceeds the UVLO level, the PWM input signal is transferred to the output side. If the output side is ready (not in UVLO condition), the output reacts according to the logic input.

2.2.2 Output supply voltage

The two output dies are powered via two independent supply voltages V_{DDA} and V_{DDB} (up to 20 V).

Two ceramic bypass capacitors must be placed between VDDA and GNDA and between VDDB and GNDB in close proximity to the device. A minimum capacitance of $20 \times C_{iss}$ (MOSFET input capacitance) is recommended to ensure an acceptable ripple (5% of V_{DDO}) on the supply pin.

The minimum supply voltage is set by the Undervoltage Lockout (UVLO) function. The gate driver output can be switched only if the output supply voltage (V_{DDA} , V_{DDB}) exceeds the output-side UVLO. Thus, it can be guaranteed that the switch transistor is not operated if the driving voltage is too low to achieve a complete and fast transition to the "on" state. Low driving voltage, in fact, could cause the power MOSFET to enter its saturation (ohmic) region with potentially destructive power dissipation; the output UVLO ensures that the

2 Functional description

switch transistor always stays within its Safe Operating Area (SOA). Versions with 4 V, 8 V, 12 V and 15 V UVLO thresholds for the output supply are currently available. [Table 3](#) shows the recommended UVLO levels for different Infineon power switch families.

Table 3 Recommended UVLO levels for typical use-cases

| Inputs | Examples of part number | Recommended driver |
|-----------------------|---------------------------------|---|
| Logic level OptiMOS™ | BSC010N04LS6, BSZ070N08LS5, .. | 2EDR7259 (4 V UVLO) |
| Normal level OptiMOS™ | BSC040N10NS5, BSZ084N08NS5, .. | 2EDR825x (8 V UVLO) |
| CoolMOS™ | IPP60R099C7, IPB60R600P6, .. | 2EDR825x (8 V UVLO) |
| 650 V CoolSiC™ | IMZA65R027M1H, IMW65R107M1H, .. | 2EDR6258/ 2EDR925x (12/15 V UVLO) |
| 650 V CoolGaN™ | IGOT60R070D1, IGLD60R070D1, .. | 2EDR7259 (4 V UVLO for unipolar driving) 2EDR825x (8 V UVLO for bipolar driving) |

2.3 Input stage - INA, INB, DISABLE

The inputs INA and INB control two independent PWM channels. The input signal is transferred non-inverted to the corresponding gate driver outputs OUTA and OUTB. All inputs are compatible with LV-TTL threshold levels and provide a hysteresis of typically 0.8 V. The hysteresis is independent of the supply voltage V_{DDI} .

The PWM inputs are internally pulled down to a logic low voltage level (GNDI). In case the PWM-controller signals have an undefined state during the power-up sequence, the gate driver outputs are forced to the "off"-state (low).

If the DIS/EN input is at high/low state, this unconditionally drives both channel outputs to low state regardless of the state of INA or INB.

[Table 4](#) and [Table 5](#) shows the INA, INB, DIS/EN driver logic in case of sufficiently high supply voltage. Otherwise the outputs of the driver are determined by the Undervoltage Lockout (UVLO) and Output Active Clamping functionalities as shown in [Table 8](#).

Table 4 Logic table in case of sufficient bias power - INA, INB, DIS

| Inputs | | DIS | Supplies | Outputs | | Note |
|-----------|-----------|----------------|---|---------|------|--|
| INA | INB | | V_{DDI} , V_{DDA} , V_{DDB} | OUTA | OUTB | |
| L | L | L or left open | > $UVLO_{VDDx,on}$ (active) | L | L | – |
| L | H | L or left open | | L | H | – |
| H | H | L or left open | | H | H | DTC/STP pin tied to VDDI or left open |
| | | | | L | L | DTC/STP pin tied to GNDI or tied to GNDI via R_{DTC} |
| Left open | Left open | L or left open | | L | L | Input pins internally pulled down |
| x | x | H | | L | L | Outputs disabled via DIS high |

2 Functional description

Table 5 **Logic table in case of sufficient bias power - INA, INB, EN**

| Inputs | | EN | Supplies | Outputs | | Note |
|-----------|-----------|----------------|---|---------|------|--|
| INA | INB | | V_{DDI} , V_{DDA} , V_{DDB} | OUTA | OUTB | |
| L | L | H | > $UVLO_{VDDx,on}$ (active) | L | L | – |
| L | H | H | | L | H | – |
| H | H | H | | H | H | DTC/STP pin tied to VDDI or left open |
| | | | | L | L | DTC/STP pin tied to GNDI via R_{DTC} |
| Left open | Left open | H | | L | L | Input pins internally pulled down |
| x | x | L or left open | | L | L | Outputs disabled via EN low |

2 Functional description

2.4 Shoot-through protection and configurable dead-time - STP/DTC

The shoot-through protection pulls down the outputs OUTA and OUTB when both input signals INA, INB are at high state. Its activation is recommended when the driver is used as half-bridge driver to prevent dangerous shoot-through due to unwanted overlap of INA and INB. A dead-time can be ensured and configured via pin STP/DTC as shown in Table 6.

Table 6 STP/DTC logic table

| Conditions on the STP/DTC pin | Shoot-through protection | Configurable dead-time |
|--|--------------------------|--|
| Tied to VDDI or left open | Disabled | Disabled |
| Connected to GNDI via resistor R_{DTC} | Enabled | Enabled with $t_{dt} [ns] = 10 \times R_{DTC} [k\Omega]$; allowed R_{DTC} range is 1.2k Ω to 100k Ω |
| Connected to GNDI | Enabled | Disabled |

The driver dead-time logic is triggered during the falling edge of an input and delays the rising transition of the other input. The delay is only assigned if the driver configured dead-time is longer than the inputs signals' own dead-time.

The dead-time can be configured by changing the current fed into the STP/DTC pin via an external resistance according to the formula: $t_{dt} [ns] = 10 \times R_{DTC} [k\Omega]$. It is recommended to use resistors with 1% accuracy in the 1.2 k Ω to 100 k Ω range. Using a resistor outside this recommended range disables the shoot-through protection and dead-time control functionality. Connecting capacitors to the DTC pin must be avoided when the dead-time control functionality is used.

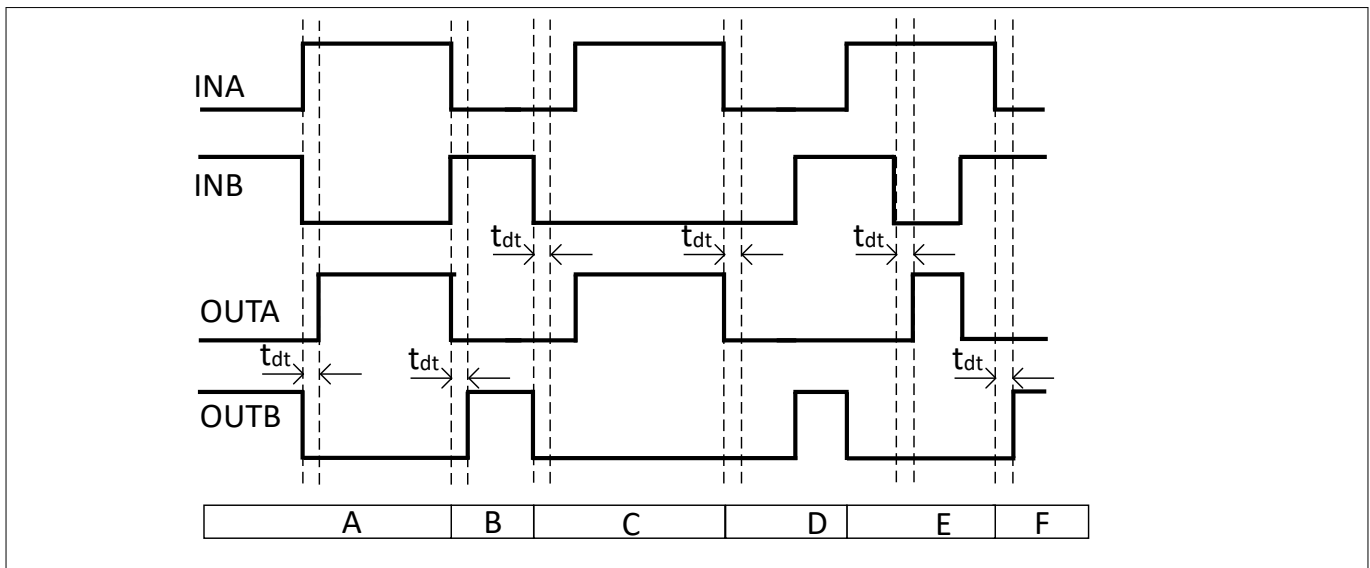

Figure 4 Logic for STP/DTC pin connected to GNDI via resistance R_{DTC}

Table 7 Logic for STP/DTC pin connected to GNDI via resistance R_{DTC}

| Condition | STP/DTC logic |
|-----------|---|
| A, B | The driver logic assigns the configured dead-time since it is longer than the input signals' dead-time |
| C, D | The driver logic does not assign the configured dead-time since it is shorter than the input signals' dead-time |

(table continues...)

2 Functional description

Table 7 (continued) Logic for STP/DTC pin connected to GNDI via resistance R_{DTC}

| Condition | STP/DTC logic |
|-----------|--|
| E, F | The shoot-through protection pulls down the outputs OUTA, OUTB until one of the outputs goes low. At this point, after the configured driver dead-time, the other output is allowed to go high |

2.5 Gate driver outputs

The rail-to-rail output stage realized with complementary MOS transistors is able to provide a typical 5 A sourcing and 9 A sinking peak current. The low on-resistance coming together with high driving current is particularly beneficial for fast switching of very large MOSFETs. With a R_{on} of $\sim 1 \Omega$ for the sourcing pMOS and $\sim 0.5 \Omega$ for the sinking nMOS transistor the driver can in most applications be considered as a nearly ideal switch. The p-channel sourcing transistor enables real rail-to-rail behavior without suffering from the voltage drop unavoidably associated with nMOS source follower stages.

In case of floating inputs or insufficient supply voltage not exceeding the UVLO thresholds, the driver outputs are actively clamped to the "low" level (GNDA, GNDB).

2.6 Fast active output clamping in UVLO conditions

The Undervoltage Lockout (UVLO) ensures that the gate driver output is not operated if the supplies are below the UVLO thresholds. However, this is not sufficient to guarantee that the output of the driver is kept low. Transients or noise in the power stage may pull-up the output node of the driver and the gate voltage causing an unwanted turn-on of the switch; this is particularly critical in system using bootstrapping since, during start-up, the supply of the high-side channel is delayed, while the low-side MOSFET is already switching. In resonant topologies (as LLC), the half-bridge switching node may be pulled up after the turn-off of the low-side switch. When the low-side MOSFET is turned on again, the high-side gate voltage increase induced by dV/dt event cannot be clamped by the driver $R_{DS(on),sink}$ if the bootstrap supply is not yet available.

With a fast output clamping circuit in the output stage, the driver ensures safe operation against output induced overshoots in all UVLO situations. This structure allows fast reaction and effective clamping of the output pins (OUTA, OUTB). The exact reaction time depends on the output supply (V_{DDA} , V_{DDB}) and on the output voltage levels; however, already for very low supply levels (~ 1 V), the active output clamp is able to react in some tens of ns.

Undervoltage Lockout together with the output active clamping ensures that the outputs are actively held low in case of insufficient supply voltages.

Table 8 Logic table in case of insufficient bias power - INA, INB, DISABLE

| Inputs | | DIS | Supplies | | | Outputs | |
|--------|-----|-----|--------------------|--------------------|--------------------|----------------|----------------|
| INA | INB | | V_{DDI} | V_{DDA} | V_{DDB} | OUTA | OUTB |
| X | X | X | $< UVLO_{VDDI,on}$ | X | X | L | L |
| X | X | X | $> UVLO_{VDDI,on}$ | $< UVLO_{VDDA,on}$ | $< UVLO_{VDDB,on}$ | L | L |
| X | X | X | $> UVLO_{VDDI,on}$ | $> UVLO_{VDDA,on}$ | $< UVLO_{VDDB,on}$ | Follows INA | L |
| X | X | X | $> UVLO_{VDDI,on}$ | $< UVLO_{VDDA,on}$ | $> UVLO_{VDDB,on}$ | L | Follows INB |

2.7 CT communication and input to output data transmission

A coreless transformer (CT) based communication module is used for PWM signal transfer between input and output. A proven high-resolution pulse repetition scheme in the transmitter combined with a watchdog timeout at the receiver side enables recovery from communication fails and ensures safe system shut-down in failure cases.

3 Electrical characteristics

3 Electrical characteristics

The absolute maximum ratings are listed in [Table 9](#). Stresses beyond these values may cause permanent damage to the device. Exposure to absolute maximum rating conditions for extended periods may affect device reliability.

3.1 Absolute maximum ratings

Table 9 Absolute maximum ratings

| Parameter | Symbol | Values | | | Unit | Note or condition |
|--|--------------------|---------------|------|-------------------|----------|--|
| | | Min. | Typ. | Max. | | |
| Input supply voltage | V_{DDI} | -0.3 | – | 18 | V | – |
| Output supply voltage at pins VDDA, VDDB | V_{DDA}, V_{DDB} | -0.3 | – | 22 ¹⁾ | V | – |
| Voltage at pins INA, INB, DIS/EN (DC) | V_{IN} | -0.3 | – | 18 | V | – |
| Voltage at pins INA, INB, DIS/EN (transient) | V_{IN} | -5 | – | – | V | transient for 50 ns ³⁾ |
| Voltage at pin DTC | V_{DTC} | ²⁾ | – | $V_{DDI} + 0.3$ | V | – |
| Voltage at pins OUTA, OUTB (DC) | V_{OUT} | -0.3 | – | $V_{DDA/B} + 0.3$ | V | – |
| Voltage at pins OUTA, OUTB (transient) | V_{OUT} | -2 | – | $V_{DDA/B} + 1.5$ | V | transient for 200 ns ³⁾ |
| Reverse current peak at pins OUTA, OUTB | I_{SRC_rev} | -5 | – | – | A_{pk} | transient for 500 ns ³⁾ |
| Reverse current peak at pins OUTA, OUTB | I_{SNK_rev} | – | – | 5 | A_{pk} | transient for 500 ns ³⁾ |
| Junction temperature | T_J | -40 | – | 150 | °C | – |
| Storage temperature | T_{STG} | -65 | – | 150 | °C | – |
| Soldering temperature | T_{SOL} | – | – | 260 | °C | reflow ⁴⁾ |
| ESD capability | V_{ESD_CDM} | – | – | 1 | kV | Charged Device Model (CDM) ⁵⁾ |
| ESD capability | V_{ESD_HBM} | – | – | 2 | kV | Human Body Model (HBM) ⁶⁾ |

- 1) Maximum positive supply voltage already complies with derating guidelines.
- 2) Minimum is given by internal regulation when DTC is operating (DTC pin connected to GND via resistance).
- 3) Not subject to production test - verified by design/characterization.
- 4) According to JEDEC-020E.
- 5) According to ANSI/ESDA/JEDEC JS-002.
- 6) According to ANSI/ESDA/JEDEC JS-001 (discharging 100 pF capacitor through 1.5 kΩ resistor).

3 Electrical characteristics

3.2 Thermal characteristics

Thermal characteristics are obtained from simulation with 65 mW applied to the driver input-side and 200 mW applied to any output channel.

Table 10 Thermal characteristics at $T_A = 25^\circ\text{C}$

| Parameter | Symbol | Value | | Unit | Note or condition |
|---|-----------------|--------------------|--------------------|------|-------------------|
| | | 1s0p ¹⁾ | 2s2p ²⁾ | | |
| Thermal resistance junction-case (top) ³⁾ | R_{thJC} | 46 | 46 | K/W | – |
| Thermal resistance junction ambient ⁴⁾ | R_{thJA25} | 107 | 69 | K/W | – |
| | R_{thJA85} | 95 | 65 | K/W | – |
| Thermal resistance junction board ⁵⁾ | R_{thJB} | – | 27 | K/W | – |
| Characterization parameter junction-top ⁶⁾ | Ψ_{thJT} | 11 | 10 | K/W | – |
| Characterization parameter junction-board ⁶⁾ | Ψ_{thJB25} | 21 | 23 | K/W | – |

1) Two-layer board as specified in JESD51-3 JEDEC-standard: no copper planes and no thermal vias for cooling, "package-alone" parameters

2) High-K board as specified in JESD51-7 JEDEC-standard: four-layers board with 2-oz inner layers copper planes and with no thermal vias for cooling

3) Obtained by simulating a cold plate test on the package top. No specific JEDEC standard exists, but a close description can be found in the ANSI SEMI standard G30-88

4) Obtained by simulating a JEDEC-standard, high-K board, as specified in JESD51-7, in an environment described in JESD51-2

5) Obtained by simulating a JEDEC-standard high-K board, as specified in JESD51-7, in an environment described in JESD51-8 with a ring cold plate fixture to control the PCB temperature

6) Estimates the junction temperature of a device in a real system and is extracted from the simulation data for obtaining R_{th} , using a procedure described in JESD51-2a (sections 6 and 7)

3 Electrical characteristics

3.3 Operating range

Table 11 Operating range

| Parameter | Symbol | Values | | | Unit | Note or condition |
|--|--------------------|---------------|------|-------------------|------|-------------------------------|
| | | Min. | Typ. | Max. | | |
| Input supply voltage at pin VDDI | V_{DDI} | 3 | – | 17 | V | Min. defined by $UVLO_{VDDI}$ |
| Output supply voltage at pin VDDA and VDDB | V_{DDA}, V_{DDB} | 4.5 | – | 20 ¹⁾ | V | 4 V UVLO option |
| Output supply voltage at pin VDDA and VDDB | V_{DDA}, V_{DDB} | 8.5 | – | 20 ¹⁾ | V | 8 V UVLO option |
| Output supply voltage at pin VDDA and VDDB | V_{DDA}, V_{DDB} | 12.9 | – | 20 ¹⁾ | V | 12 V UVLO option |
| Output supply voltage at pin VDDA and VDDB | V_{DDA}, V_{DDB} | 15.6 | – | 20 ¹⁾ | V | 15 V UVLO option |
| Input voltage at pins INA, INB, DIS/EN | V_{IN} | 0 | – | 17 | V | – |
| Input voltage at pin DTC | V_{DTC} | ²⁾ | – | V_{DDI} | V | – |
| Junction temperature | T_J | -40 | – | 150 ³⁾ | °C | |
| Ambient temperature | T_A | -40 | – | 125 | °C | – |

- 1) Maximum positive supply voltage already complies with derating guidelines.
 2) Minimum is given by internal regulation when DTC is operating (DTC pin connected to GND via resistance).
 3) Continuous operation above 125°C may reduce lifetime.

3.4 Electrical characteristics

Unless otherwise noted, the electrical characteristics are given for $V_{DDI} = 3.3$ V, $V_{DDA/B} = 12$ V and no load. Typical values are given at $T_J = 25^\circ\text{C}$ whilst min. and max., instead, are the lower and upper limits, respectively, within the full operating range.

Table 12 Power supply

| Parameter | Symbol | Values | | | Unit | Note or condition |
|---------------------------|---------------|--------|------|------|------|--------------------------------|
| | | Min. | Typ. | Max. | | |
| IVDDI quiescent current | I_{VDDIq} | – | 1.67 | 2.12 | mA | no switching |
| IVDDA/B quiescent current | $I_{VDDA/Bq}$ | – | 0.62 | 0.86 | mA | OUT = low, $V_{DDA/B} = 12$ V |
| IVDDA/B quiescent current | $I_{VDDA/Bq}$ | – | 0.66 | 0.89 | mA | OUT = low, $V_{DDA/B} = 18$ V |
| IVDDA/B quiescent current | $I_{VDDA/Bq}$ | – | 0.76 | 1.0 | mA | OUT = high, $V_{DDA/B} = 12$ V |
| IVDDA/B quiescent current | $I_{VDDA/Bq}$ | – | 0.9 | 1.14 | mA | OUT = high, $V_{DDA/B} = 18$ V |

3 Electrical characteristics

Table 13 Undervoltage Lockout VDDI

| Parameter | Symbol | Values | | | Unit | Note or condition |
|---|--------------------------|--------|------|------|------|-------------------|
| | | Min. | Typ. | Max. | | |
| Undervoltage Lockout (UVLO) turn-on threshold VDDI | UVLO _{VDDI,on} | – | 2.85 | 2.95 | V | – |
| Undervoltage Lockout (UVLO) turn-off threshold VDDI | UVLO _{VDDI,off} | 2.55 | 2.7 | – | V | – |
| UVLO threshold hysteresis VDDI | UVLO _{VDDI,hys} | 0.10 | 0.15 | 0.20 | V | – |

Table 14 Undervoltage Lockout VDDA, VDDB for 4 V UVLO option

| Parameter | Symbol | Values | | | Unit | Note or condition |
|---|--|--------|------|------|------|-------------------|
| | | Min. | Typ. | Max. | | |
| Undervoltage Lockout (UVLO) turn-on threshold VDDA, VDDB | UVLO _{VDDA,on} UVLO _{VDDB,on} | – | 4.2 | 4.4 | V | – |
| Undervoltage Lockout (UVLO) turn-off threshold VDDA, VDDB | UVLO _{VDDA,off} UVLO _{VDDB,off} | 3.7 | 3.9 | – | V | – |
| UVLO threshold hysteresis VDDA, VDDB | UVLO _{VDDA,hys} UVLO _{VDDB,hys} | 0.2 | 0.3 | 0.4 | V | – |

Table 15 Undervoltage Lockout VDDA, VDDB for 8 V UVLO option

| Parameter | Symbol | Values | | | Unit | Note or condition |
|---|--|--------|------|------|------|-------------------|
| | | Min. | Typ. | Max. | | |
| Undervoltage Lockout (UVLO) turn-on threshold VDDA, VDDB | UVLO _{VDDA,on} UVLO _{VDDB,on} | – | 8.0 | 8.5 | V | – |
| Undervoltage Lockout (UVLO) turn-off threshold VDDA, VDDB | UVLO _{VDDA,off} UVLO _{VDDB,off} | 6.6 | 7.0 | – | V | – |
| UVLO threshold hysteresis VDDA, VDDB | UVLO _{VDDA,hys} UVLO _{VDDB,hys} | 0.7 | 1 | 1.3 | V | – |

3 Electrical characteristics

Table 16 Undervoltage Lockout VDDA, VDDB for 12 V UVLO option

| Parameter | Symbol | Values | | | Unit | Note or condition |
|---|--|--------|------|------|------|-------------------|
| | | Min. | Typ. | Max. | | |
| Undervoltage Lockout (UVLO) turn-on threshold VDDA, VDDB | UVLO _{VDDA,on} UVLO _{VDDB,on} | – | 12.2 | 12.8 | V | – |
| Undervoltage Lockout (UVLO) turn-off threshold VDDA, VDDB | UVLO _{VDDA,off} UVLO _{VDDB,off} | 10.8 | 11.5 | – | V | – |
| UVLO threshold hysteresis VDDA, VDDB | UVLO _{VDDA,hys} UVLO _{VDDB,hys} | 0.5 | 0.7 | 0.9 | V | – |

Table 17 Undervoltage Lockout VDDA, VDDB for 15 V UVLO option

| Parameter | Symbol | Values | | | Unit | Note or condition |
|---|--|--------|------|------|------|-------------------|
| | | Min. | Typ. | Max. | | |
| Undervoltage Lockout (UVLO) turn-on threshold VDDA, VDDB | UVLO _{VDDA,on} UVLO _{VDDB,on} | – | 14.9 | 15.5 | V | – |
| Undervoltage Lockout (UVLO) turn-off threshold VDDA, VDDB | UVLO _{VDDA,off} UVLO _{VDDB,off} | 13.7 | 14.4 | – | V | – |
| Duplicate of UVLO threshold hysteresis VDDA, VDDB | UVLO _{VDDA,hys} UVLO _{VDDB,hys} | 0.3 | 0.5 | 0.7 | V | – |

Table 18 Logic inputs INA, INB, DISABLE

| Parameter | Symbol | Values | | | Unit | Note or condition |
|---|---------------------|--------|------|------|------|--------------------------|
| | | Min. | Typ. | Max. | | |
| Input voltage threshold for transition LH | V _{INH} | – | 2.0 | 2.36 | V | – |
| Input voltage threshold for transition HL | V _{INL} | 0.9 | 1.2 | – | V | – |
| Input voltage threshold hysteresis | V _{IN,hys} | 0.38 | 0.8 | 1.2 | V | – |
| High-level input leakage current | I _{IN} | – | 22 | 27 | μA | INA/INB pin tied to VDDI |
| Input pull-down resistor | R _{IN,PD} | – | 150 | – | kΩ | – |

3 Electrical characteristics

Table 19 Dead-time control (DTC) and shoot-through protection (STP)

| Parameter | Symbol | Values | | | Unit | Note or condition |
|---------------------------------------|-----------------------|--------|------|------|------|---|
| | | Min. | Typ. | Max. | | |
| Dead-time | t_{dt} | 85 | 100 | 115 | ns | $R_{DTC} = 10\text{ k}\Omega$ |
| Dead-time | t_{dt} | 255 | 300 | 345 | ns | $R_{DTC} = 30\text{ k}\Omega$ |
| Dead-time | t_{dt} | 800 | 950 | 1100 | ns | $R_{DTC} = 100\text{ k}\Omega$ ¹⁾ |
| Channel-to-channel dead-time mismatch | $\Delta t_{dt,Ch-Ch}$ | 0 | – | 10 | ns | $R_{DTC} = 10\text{ k}\Omega$ |
| Channel-to-channel dead-time mismatch | $\Delta t_{dt,Ch-Ch}$ | 0 | – | 14 | ns | $R_{DTC} = 30\text{ k}\Omega$ |
| Channel-to-channel dead-time mismatch | $\Delta t_{dt,Ch-Ch}$ | 0 | – | 40 | ns | $R_{DTC} = 100\text{ k}\Omega$ ¹⁾ |
| Part-to-part dead-time mismatch | $\Delta t_{dt,p-p}$ | 0 | – | 20 | ns | $R_{DTC} = 10\text{ k}\Omega$ ²⁾ |
| Part-to-part dead-time mismatch | $\Delta t_{dt,p-p}$ | 0 | – | 55 | ns | $R_{DTC} = 30\text{ k}\Omega$ ²⁾ |
| Part-to-part dead-time mismatch | $\Delta t_{dt,p-p}$ | 0 | – | 105 | ns | $R_{DTC} = 100\text{ k}\Omega$ ^{1) 2)} |

1) Not subject to production test - verified by design/characterization.

2) The parameter gives the difference in the dead-time inserted from different samples under the same conditions, including same ambient temperature.

Table 20 Static output characteristics

| Parameter | Symbol | Values | | | Unit | Note or condition |
|---|---------------|--------|------|------|----------|---|
| | | Min. | Typ. | Max. | | |
| High-level (sourcing) output resistance | R_{on_SRC} | 0.6 | 0.95 | 1.5 | Ω | $I_{SRC} = 50\text{ mA}$ |
| Peak sourcing output current | I_{SRC_pk} | – | 5 | – | A | $C_{LOAD} = 22\text{ nF}$ ¹⁾ |
| Low-level (sinking) output resistance | R_{on_SNK} | 0.24 | 0.39 | 0.62 | Ω | $I_{SNK} = 50\text{ mA}$ |
| Peak sinking output current | I_{SNK_pk} | | -9 | – | A | $C_{LOAD} = 22\text{ nF}$ ¹⁾ |

1) Not subject to production test - verified by design/characterization.

Table 21 Dynamic characteristics

| Parameter | Symbol | Values | | | Unit | Note or condition |
|---------------------------------------|----------------|--------|------|------|------|---|
| | | Min. | Typ. | Max. | | |
| INx to OUTx turn-on propagation delay | $t_{pDon,INx}$ | 33 | 38 | 47 | ns | See Figure 5 , Figure 6 |

(table continues...)

3 Electrical characteristics

Table 21 (continued) Dynamic characteristics

| Parameter | Symbol | Values | | | Unit | Note or condition |
|--|----------------------------|--------|------|------|------|--|
| | | Min. | Typ. | Max. | | |
| INx to OUTx turn-off propagation delay | $t_{PDoff,INx}$ | 30 | 36 | 46 | ns | See Figure 5 , Figure 6 |
| Part-to-part turn-on propagation delay mismatch | $\Delta t_{PDon,p-p}$ | 0 | – | 6 | ns | ¹⁾ |
| Part-to-part turn-off propagation delay mismatch | $\Delta t_{PDoff,p-p}$ | 0 | – | 8 | ns | ¹⁾ |
| Channel-to-channel turn-on propagation delay mismatch | $t_{PDon,ChA-ChB}$ | -4 | – | 4 | ns | See Figure 7 ²⁾ |
| Channel-to-channel turn-off propagation delay mismatch | $\Delta t_{PDoff,ChA-ChB}$ | -5.5 | – | 3 | ns | See Figure 7 ²⁾ |
| Pulse width distortion | t_{PWD} | -5 | 2 | 5.5 | ns | See Figure 8 ³⁾ |
| Channel turn-off to channel turn-on propagation delay mismatch | t_{DTD} | -5 | -2 | 1 | ns | See Figure 9 ⁴⁾ ⁵⁾ |
| Rise time | t_{rise} | – | 7.5 | 14 | ns | $C_{LOAD} = 1.8$ nF, see Figure 10 ⁶⁾ |
| Fall time | t_{fall} | – | 6 | 11 | ns | $C_{LOAD} = 1.8$ nF, see Figure 10 ⁶⁾ |
| Minimum input pulse width that changes output state | t_{PW} | 10 | 17 | 25 | ns | See Figure 11 |
| Input-side start-up time | $t_{START,VDDI}$ | – | 3.5 | 5 | μs | See Figure 12 ⁶⁾ |
| Input-side deactivation time | $t_{STOP,VDDI}$ | 600 | 750 | – | ns | See Figure 12 ⁶⁾ |
| Output-side start-up time | $t_{START,VDDA/B}$ | – | 2.5 | 5 | μs | See Figure 13 ⁶⁾ |
| Output-side deactivation time | $t_{STOP,VDDA/B}$ | 500 | 800 | – | ns | See Figure 13 ⁶⁾ |

- 1) The parameter gives the difference in the propagation delay between different samples switching in the same direction under same conditions, including same ambient temperature; therefore, is an indication of the production spread. The limits given are valid for all channels combination: $t_{PD_ChA} - t_{PD_ChA}$, $t_{PD_ChB} - t_{PD_ChB}$, $t_{PD_ChA} - t_{PD_ChB}$, $t_{PD_ChB} - t_{PD_ChA}$.
- 2) The parameter gives the difference in the propagation delay of channel A and channel B switching in the same direction in the same sample.
- 3) The parameter gives the difference between ON and OFF propagation delay in the same channel (ChA or ChB), in the same sample at same ambient temperature.
- 4) The parameter gives the difference between the ON propagation delay of one channel and the OFF propagation delay of the other channel, in the same sample at same room temperature. This parameter represents the distortion of the inputs dead-time only when the driver DTC is not used or not enforced otherwise, please refer to "Dead-time and shoot-through protection" table.

3 Electrical characteristics

- 5) Not subject to production test - verified by characterization.
 6) Not subject to production test - verified by design/characterization.

Table 22 Thermal shutdown

| Parameter | Symbol | Values | | | Unit | Note or condition |
|------------------------------------|------------------|--------|------|------|------|-------------------|
| | | Min. | Typ. | Max. | | |
| Thermal shutdown rising threshold | T_{SHUT_RISE} | – | 172 | – | °C | 1) |
| Thermal shutdown falling threshold | T_{SHUT_FALL} | – | 149 | – | °C | 1) |

1) Not subject to production test - specified by characterization.

Table 23 Common-Mode Transient Immunity (CMTI)

| Parameter | Symbol | Values | | | Unit | Note or condition |
|---------------------------------------|-------------------|--------|------|------|------|--|
| | | Min. | Typ. | Max. | | |
| Static Common-Mode Transient Immunity | $ CM_{Static,H} $ | 150 | – | – | V/ns | $V_{CM} = 1500\text{ V}$; INA, INB tied to V_{DDI} (logic high inputs) 1) |
| Static Common-Mode Transient Immunity | $ CM_{Static,L} $ | 150 | – | – | V/ns | $V_{CM} = 1500\text{ V}$; INA, INB tied to GNDI (logic low inputs) 1) |

1) Minimum slew rate of a common-mode voltage that is able to cause an incorrect output signal

3.5 Isolation specifications

Table 24 Isolation specifications

| Parameter | Symbol | Value | Unit | Note or condition |
|---|--------|---------|------|--|
| External input-to-output creepage 1) | CRP | 8 | mm | Shortest distance over package surface from any input pin to any output pin according to IEC 60664-1 |
| External input-to-output clearance 1) | CLR | 8 | mm | Shortest distance in air from any input pin to any output pin according to IEC 60664-1 |
| Comparative tracking index | CTI | > 400 | V | According to DIN EN 60112 (VDE 0303-11) |
| Material group | – | II | – | According to IEC 60112 |
| Pollution degree | – | II | – | According to IEC 60664-1 |
| Overvoltage category (for reinforced isolation) | – | I - IV | – | Rated mains voltage $\leq 150\text{ V}_{RMS}$ |
| | – | I - IV | – | Rated mains voltage $\leq 300\text{ V}_{RMS}$ |
| | – | I - III | – | Rated mains voltage $\leq 600\text{ V}_{RMS}$ |

Input-to-output isolation according to UL1577 Ed.5 2)
 (table continues...)

3 Electrical characteristics

Table 24 (continued) Isolation specifications

| Parameter | Symbol | Value | Unit | Note or condition |
|---|------------|--------------|-----------------------|--|
| Input-to-output isolation voltage | V_{ISO} | 5700 | V_{RMS} | $V_{TEST} = V_{ISO}$ for $t = 60$ s (qualification); $V_{TEST} = 1.2 \times V_{ISO}$ for $t = 1$ s (100% productive tests) |
| Input-to-output isolation according to DIN VDE V0884-11 and IEC 60747-17^{3) 4)} | | | | |
| Maximum impulse voltage | V_{IMP} | 8000 | V_{pk} | According to IEC 60664-1 |
| Maximum rated transient isolation voltage | V_{IOTM} | 8000 | V_{pk} | $V_{TEST} = V_{IOTM}$ for $t_{ini} = 60$ s (type tests) $V_{TEST} = 1.2 \times V_{IOTM}$ for $t_{ini} = 1$ s (100% productive tests) |
| Maximum rated repetitive isolation voltage | V_{IORM} | 1767 | V_{pk} | According to Time Dependent Dielectric Breakdown (TDDB) Test for reinforced isolation |
| Maximum isolation working voltage | V_{IOWM} | 1767 1250 | V_{DC} V_{RMS} | |
| Apparent charge | q_{PD} | < 5 | pC | $V_{ini,b1} = 1.2 \times V_{IOTM}$ (100% productive tests) and $V_{ini,b1} = V_{IOTM}$ (type tests preconditioning) for $t_{ini} = 1$ s $V_{pd(m)} = 1.875 \times V_{IORM}$ for $t_m = 1$ s ⁵⁾ After subgroup 1 life tests (type test) $V_{ini,a} = V_{IOTM}$ for $t_{ini} = 60$ s $V_{pd(m)} = 1.6 \times V_{IORM}$ for $t_m = 10$ s After subgroup 2, 3 endurance tests (type test) $V_{ini,a} = V_{IOTM}$ for $t_{ini} = 60$ s $V_{pd(m)} = 1.2 \times V_{IORM}$ for $t_m = 10$ s |
| Maximum surge isolation voltage ⁶⁾ | V_{IOSM} | 6875 | V_{pk} | $V_{IOSM_TEST} = 1.6 \times V_{IOSM}$ for reinforced isolation according VDE 0884-11 |
| | | 11000 | V_{pk} | $V_{IOSM_TEST} = 11 \text{ kV}_{pk} \geq 1.3 \times V_{IOSM}$ for reinforced isolation according IEC 60747-17 |
| Isolation resistance input-to-output ⁷⁾ | R_{IO} | 10^{12} | Ω | $V_{IO} = 500 \text{ V}_{dc}$ for $t = 60$ s, $T_A = 25^\circ\text{C}$ (type tests subgroup 1) |
| | | 10^{11} | Ω | $V_{IO} = 500 \text{ V}_{dc}$ for $t = 60$ s, $T_A = 125^\circ\text{C}$ (type tests preconditioning, type test subgroup 4) |
| | | 10^9 | Ω | $V_{IO} = 500 \text{ V}_{dc}$ for $t = 60$ s, $T_A = 25^\circ\text{C}$ (type tests subgroup 1, 2, 3) or $T_A = T_S$ (type tests subgroup 4) |
| Capacitance input-to-output ⁷⁾ | C_{IO} | 2 | pF | $f = 1 \text{ MHz}$ |

1) Creepage and clearance requirements depend on the application and related end-equipment isolation standard. Care should be taken to keep the required creepage and clearance value on printed-circuit-board level.

3 Electrical characteristics

2) See UL 1577 certificate n. E311313.

3) This coupler is suitable for "safe electrical insulation" only within the safety ratings. Compliance with the safety ratings shall be ensured by means of suitable protective circuits.

4) See IEC 60747-17 certificate n. 40055138.

5) The partial discharge voltage VPD(m) applied during production tests is greater ($4411 \text{ Vpk} > 1.875 \times \text{VIORM}$) to include the F4 factor required by end equipment standards IEC 60664-1, IEC 62368-1 ($\text{VPD(m)} = F1 \times F2 \times F3 \times F4 \times \text{VIORM} = 1.875 \times F4 \times \text{VIORM}$).

6) The surge test is performed in insulation oil to determine the intrinsic surge immunity of the insulation barrier.

7) The parameters apply to the product converted in a two terminals device with all terminals on side 1 connected together and all terminals on side 2 connected together.

Table 25 Output channel-to-channel isolation specifications

| Parameter | Symbol | Value | Unit | Note or condition |
|--|-----------------------------|-------|------|--|
| External channel-to-channel creepage ¹⁾ | CRP _{Ch-Ch, 14pin} | 3.3 | mm | Shortest distance over package surface between any output channel A pin and any output channel B pin |
| | CRP _{Ch-Ch, 16pin} | 2.5 | mm | |

1) Creepage and clearance requirements depend on the application and related end-equipment isolation standard. Care should be taken to keep the required creepage and clearance value on printed-circuit-board level

3.5.1 Safety-limiting values

Table 26 Reinforced isolation safety-limiting values as outlined in IEC 60747-17

| Parameter | Side | Value | Unit | Note or condition |
|------------------------|------------|-------|------|---|
| Safety supply power | Input chip | 76 | mW | $R_{thJA} = 69 \text{ K/W}^{1)}$ $T_{amb} = 25^\circ\text{C}$ $T_j = 150^\circ\text{C}$ |
| | Output A | 868 | mW | |
| | Output B | 868 | mW | |
| | Total | 1812 | mW | |
| Safety supply currents | Output A | 72.3 | mA | $R_{thJA} = 69 \text{ K/W}^{1)}$ $V_{DDA}/V_{DDB} = 12 \text{ V}$ $T_{amb} = 25^\circ\text{C}, T_j = 150^\circ\text{C}$ |
| | Output B | 72.3 | mA | |
| | Output A | 43.4 | mA | $R_{thJA} = 69 \text{ K/W}^{1)}$ $V_{DDA}/V_{DDB} = 20 \text{ V}$ $T_{amb} = 25^\circ\text{C}, T_j = 150^\circ\text{C}$ |
| | Output B | 43.4 | mA | |
| Safety temperature | T_s | 150 | °C | $T_s = T_{j,max}$ |

1) RthJA based on high-K board JEDEC-standard as specified in JESD51-7: four-layers board with 2-oz inner layers copper planes and with no thermal vias for cooling (see Table 10)

According to IEC 60747-17 and UL1577, safety-limiting values define the operating conditions under which the isolation barrier can be guaranteed to stay unaffected. This corresponds with the maximum allowed junction temperature, as temperature-induced failures might cause significant overheating and eventually damage the isolation barrier.

4 Timing diagrams

4 Timing diagrams

Figure 5 illustrates the input-to-output propagation delays as observed at the capacitively loaded output.

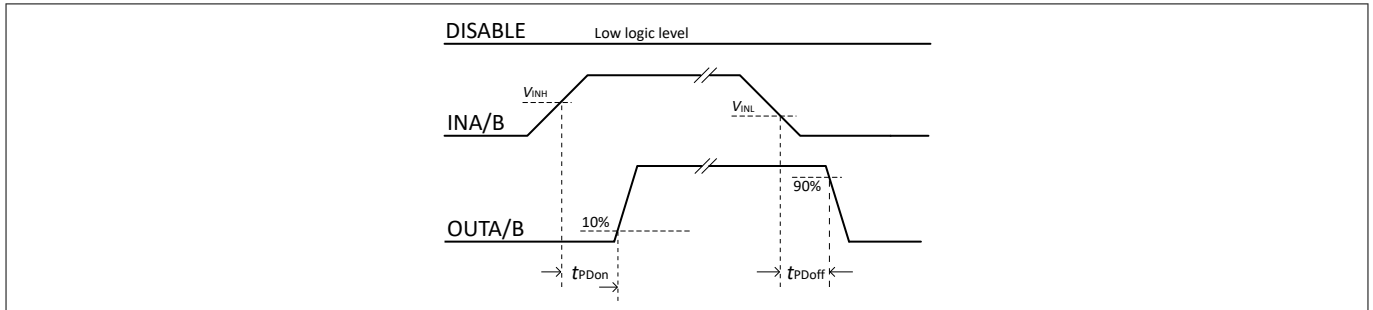

Figure 5 INx to OUTx propagation delays

Figure 6 illustrates the disable-to-output propagation delays as observed at the capacitively loaded output.

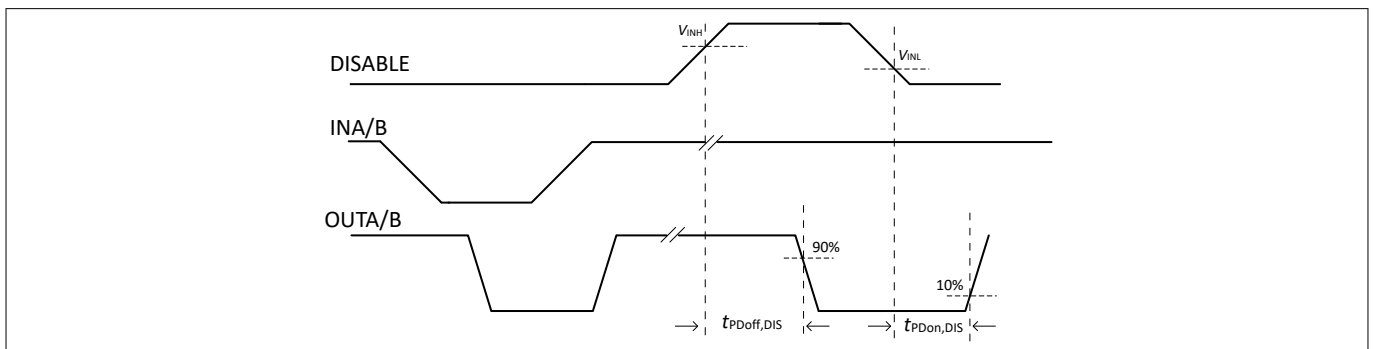

Figure 6 DISABLE to OUTx propagation delays

Figure 7 illustrates the channel-to-channel propagation delay mismatch at the unloaded outputs. This parameter is relevant when the channels drive parallel switches as it represents the delay in the two driving signals.

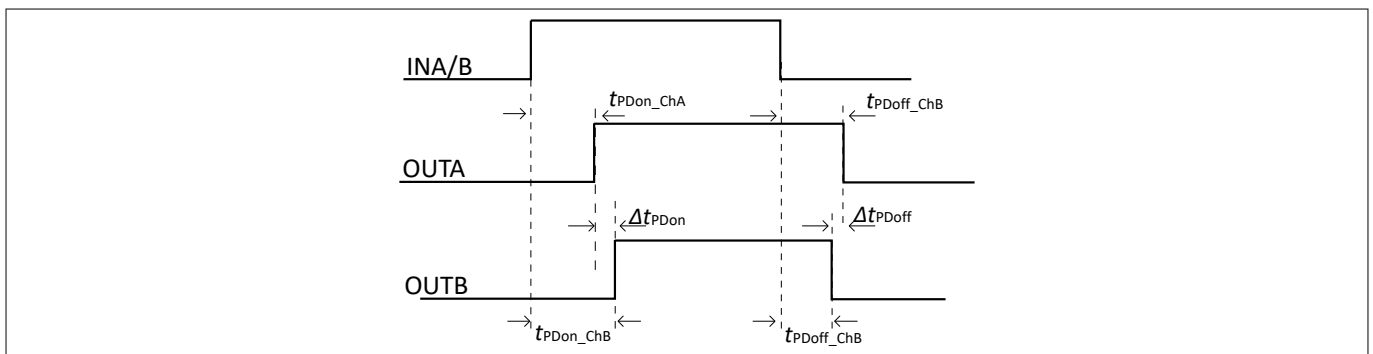

Figure 7 Channel-to-channel propagation delay mismatch

Figure 8 illustrates the pulse width distortion at the unloaded output. Ideally the width of the input pulse (t_{PW_INx}) equals the width of the output pulse (t_{PW_OUTx}); however, the driver introduces an output pulse distortion t_{PW} given by the difference between ON and OFF propagation delay.

4 Timing diagrams

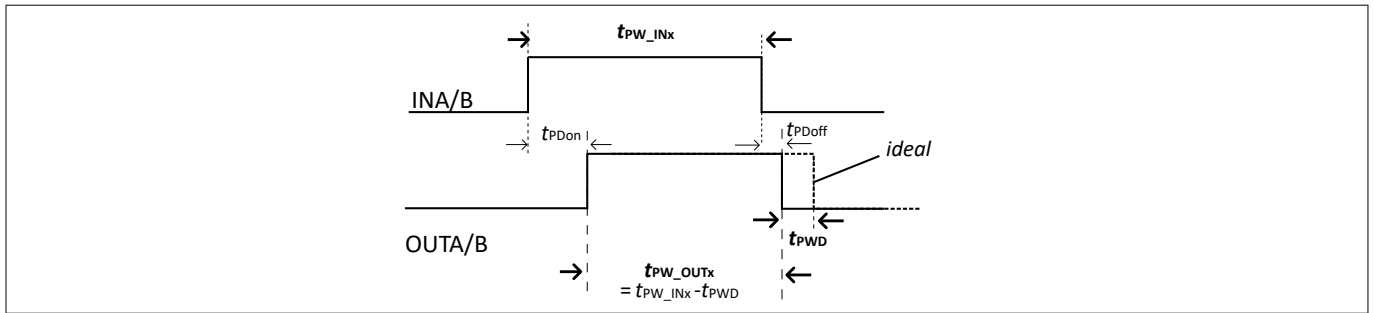

Figure 8 Pulse width distortion

Figure 9 illustrates the dead-time distortion at the unloaded outputs. This parameter is relevant in operation with complementary signals, as for the half-bridge driving when a certain dead-time t_{DT_INx} is set on the inputs INA, INB. Ideally the dead-time on the driver output (t_{DT_OUTx}) equals the input dead-time; however, the driver introduces a distortion t_{DTc} given by the difference between the OFF propagation delay of one channel and the ON propagation delay of the other channel.

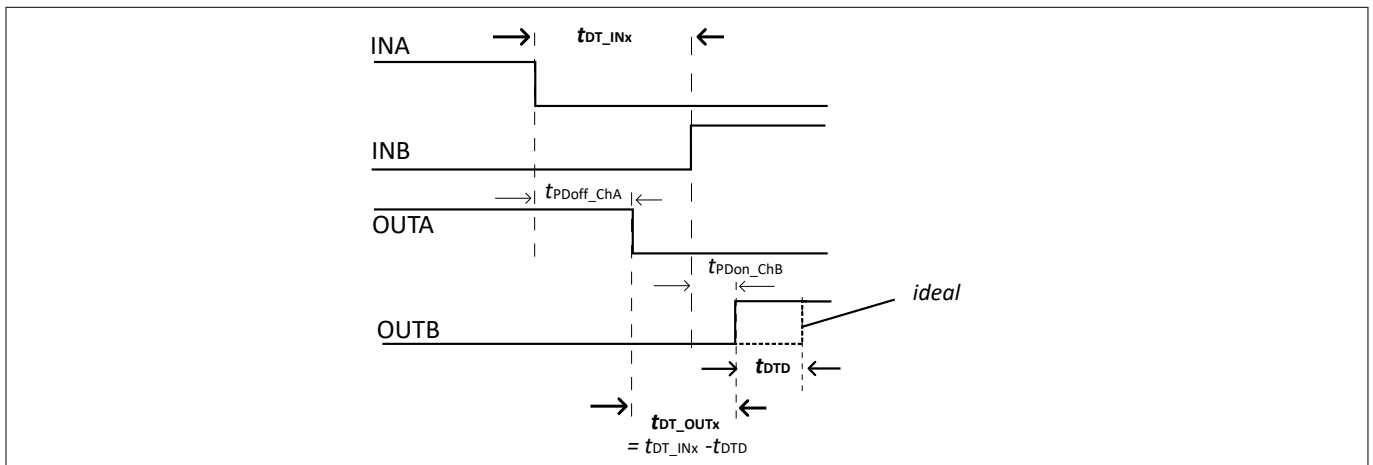

Figure 9 Channel turn-off to channel turn-on propagation delay mismatch

Figure 10 illustrates the rise and fall time as observed at the capacitively loaded output.

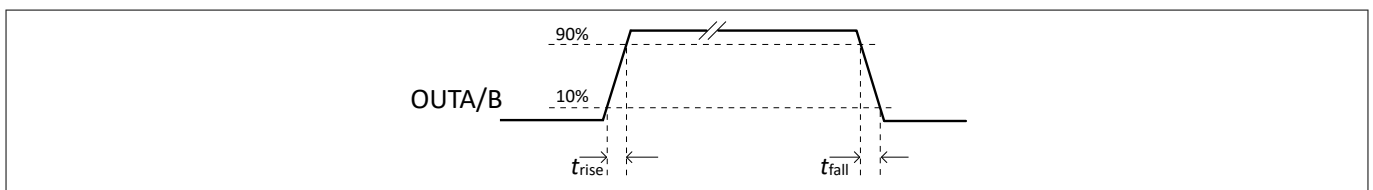

Figure 10 Rise and fall time

Figure 11 illustrates the behavior of the deglitch filter that filters spurious pulses on INA, INB with duration shorter than t_{PWmin} .

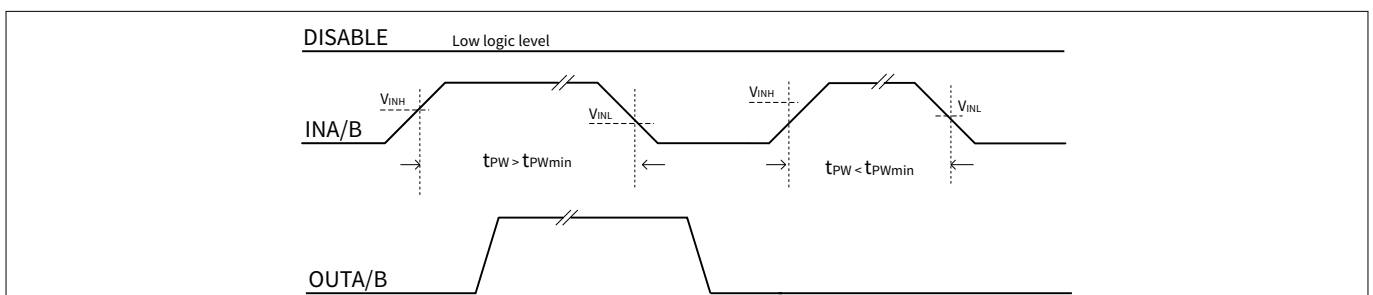

Figure 11 Minimum pulse that changes the output state

4 Timing diagrams

Figure 12 illustrates the input-side supply UVLO behavior. It depicts the reaction time to UVLO events when V_{DDI} crosses the UVLO thresholds during rising or falling transitions (power-up, power-down, supply noise).

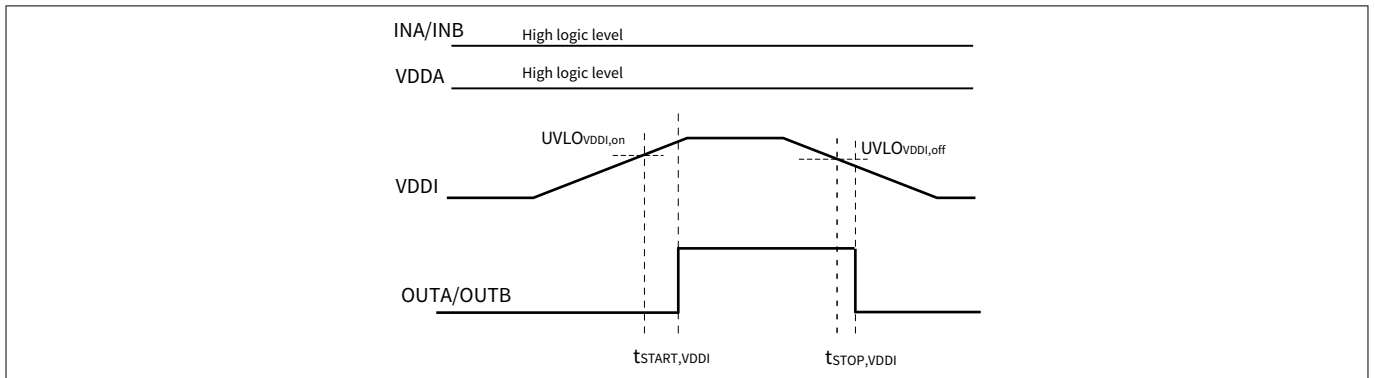

Figure 12 V_{DDI} UVLO behavior, start-up and deactivation time

Figure 13 illustrates the output-side supply UVLO behavior. It depicts the reaction time to UVLO events when $V_{DDA/B}$ crosses the UVLO thresholds during rising or falling transitions (power-up, power-down, supply noise).

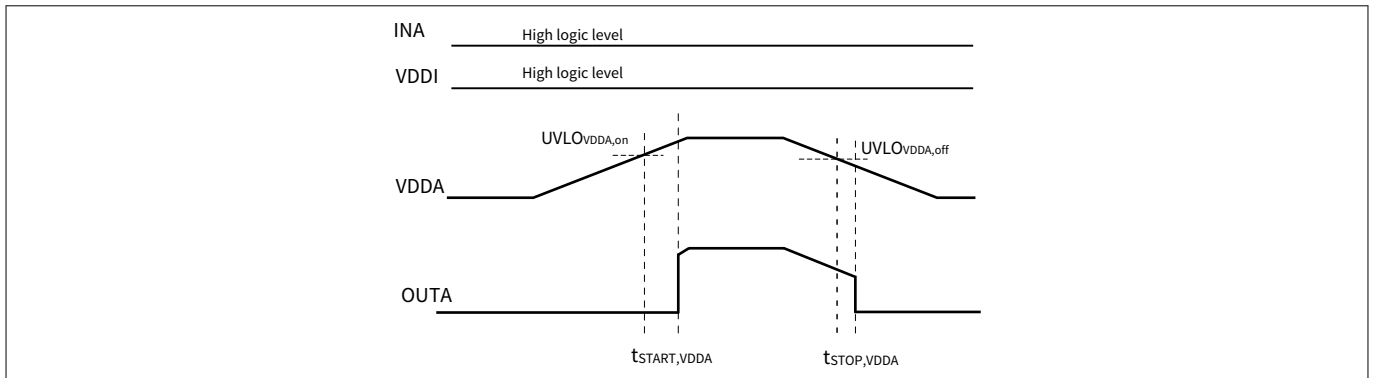

Figure 13 V_{DDA}, V_{DDB} UVLO behavior, start-up and deactivation time

Figure 14 illustrates the shoot-through protection and dead-time logic. When enabled, the dead-time is added on top of the turn-off propagation delay if the driver dead-time is longer than the signals' own dead-time.

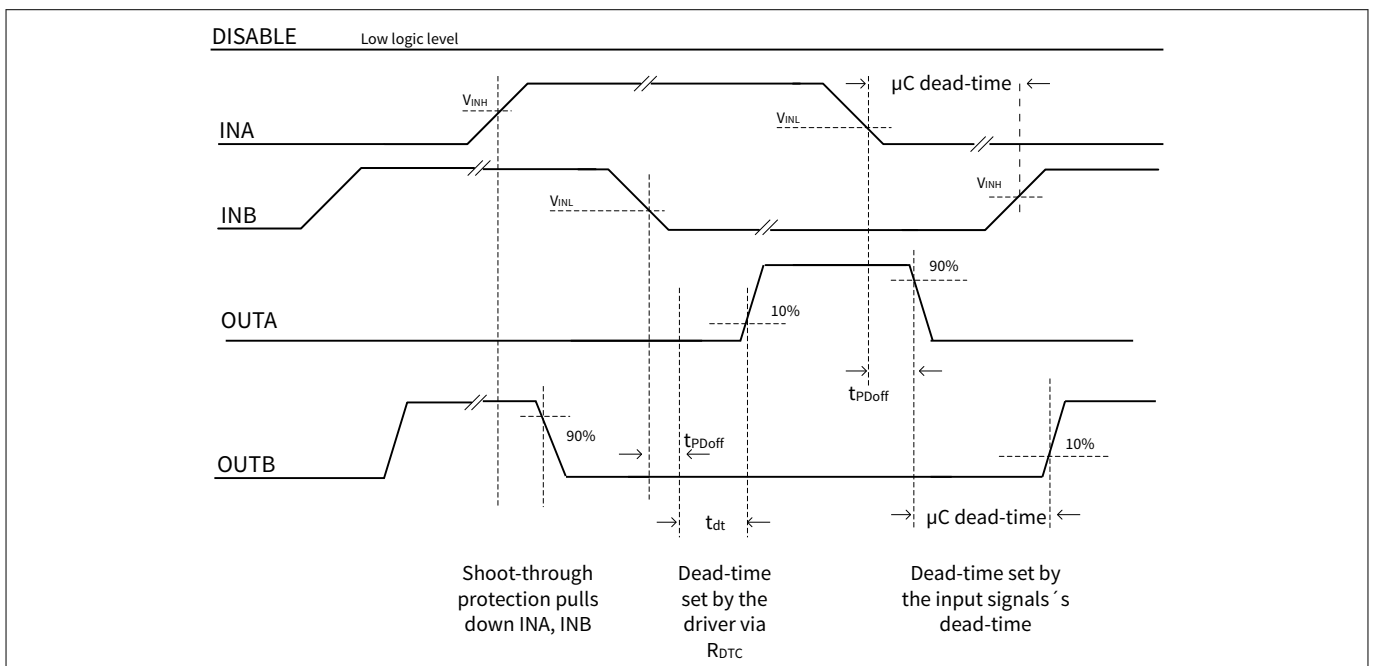

Figure 14 Shoot-through and configurable dead-time

5 Typical characteristics

5 Typical characteristics

$V_{DDI} = 3.3\text{ V}$, $V_{DDA/B} = 12\text{ V}$, $T_A = 25^\circ\text{C}$, $f_{sw} = 1\text{ MHz}$, no load unless otherwise noted

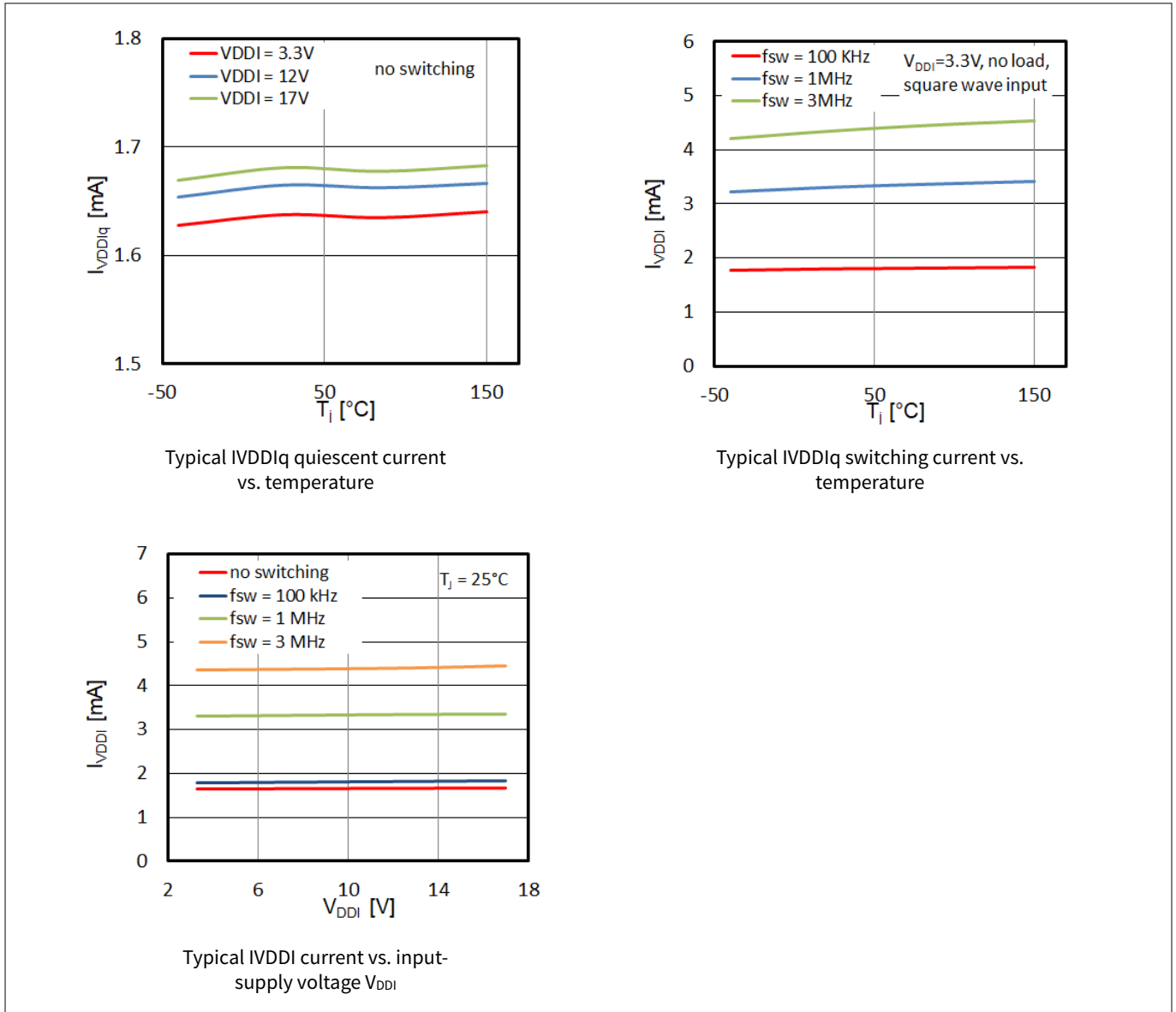

Figure 15 Input-side supply current

5 Typical characteristics

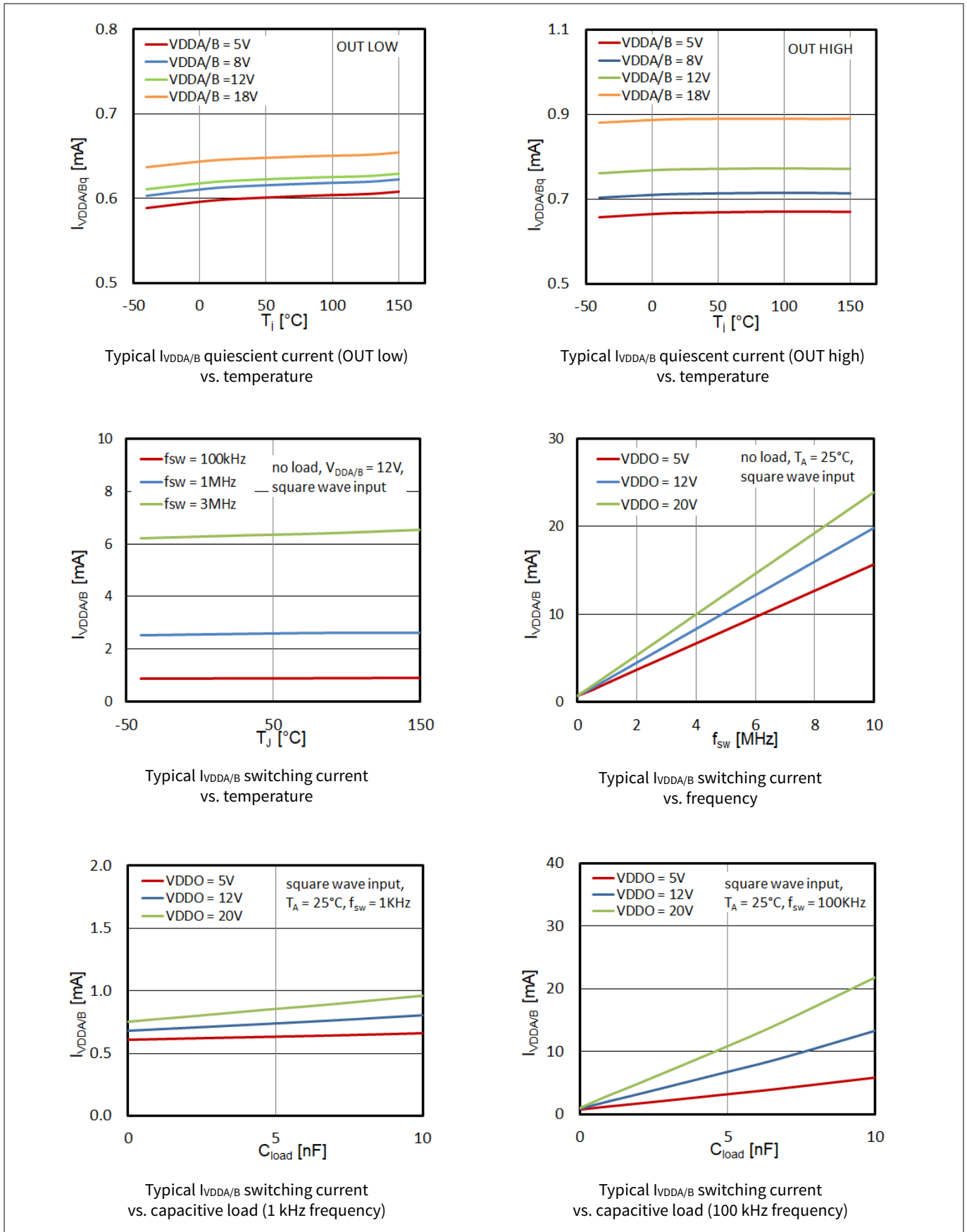

Figure 16 Output-side supply current

5 Typical characteristics

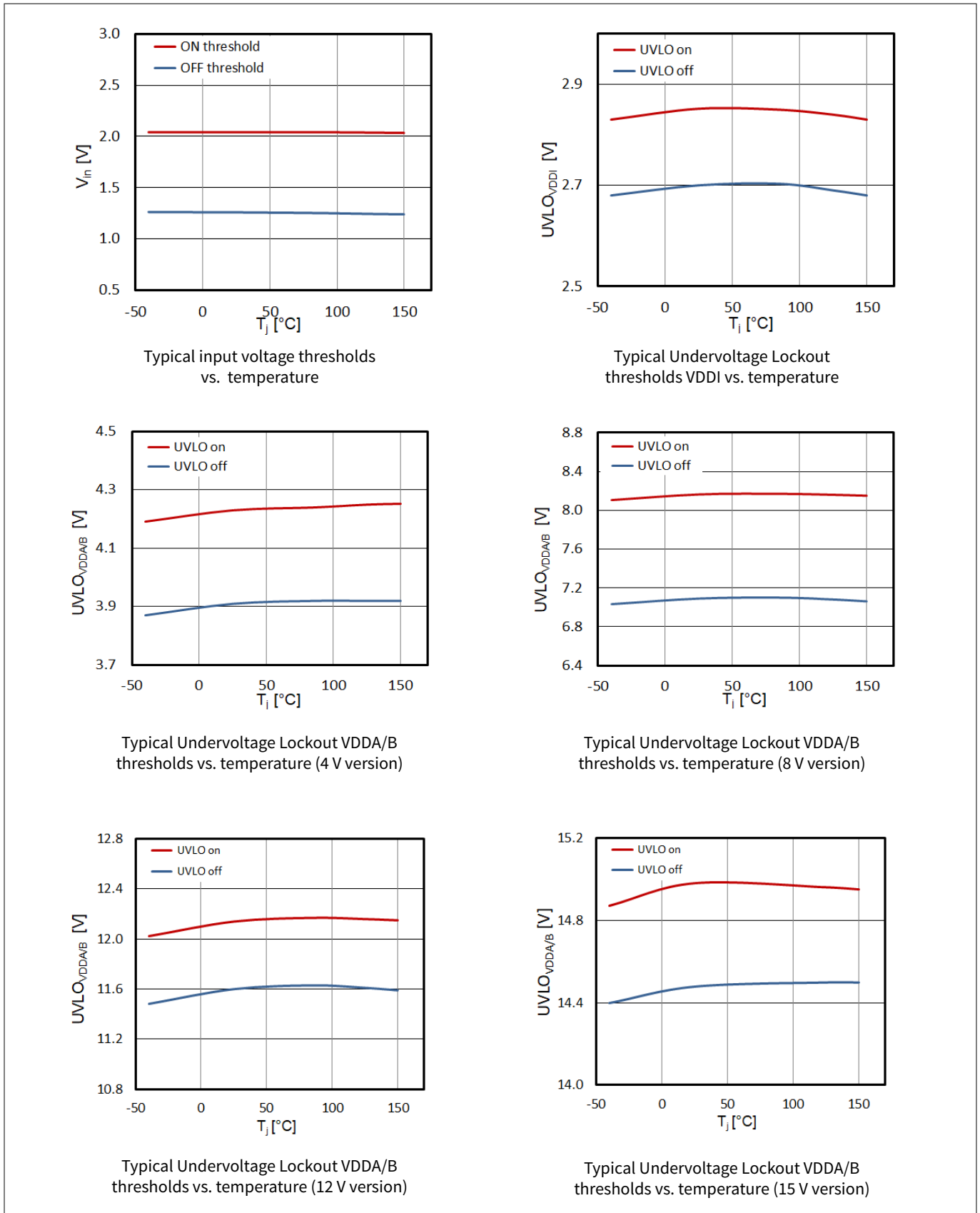

Figure 17 Input voltage thresholds and undervoltage lockout

5 Typical characteristics

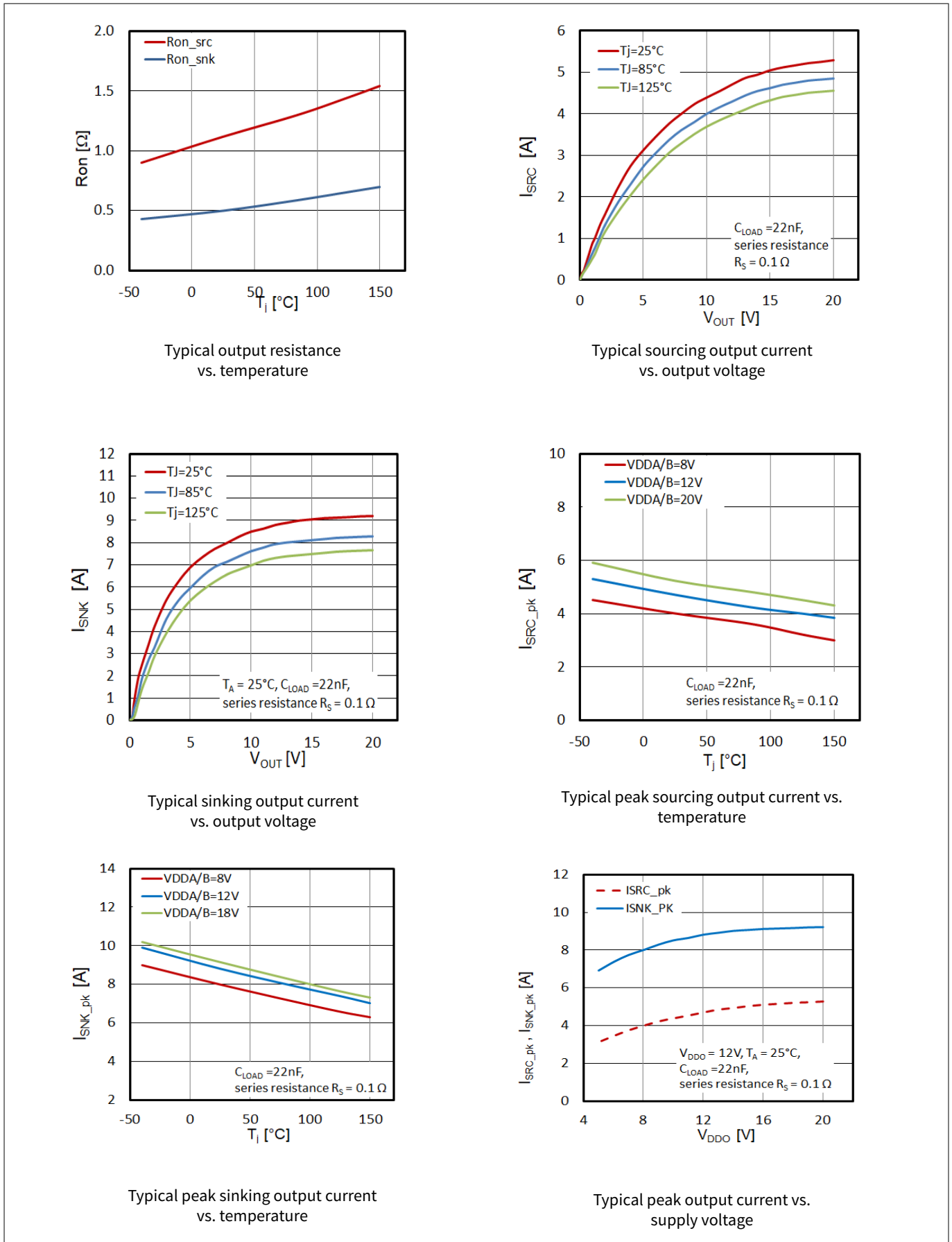

Figure 18 Typical output static characteristics

5 Typical characteristics

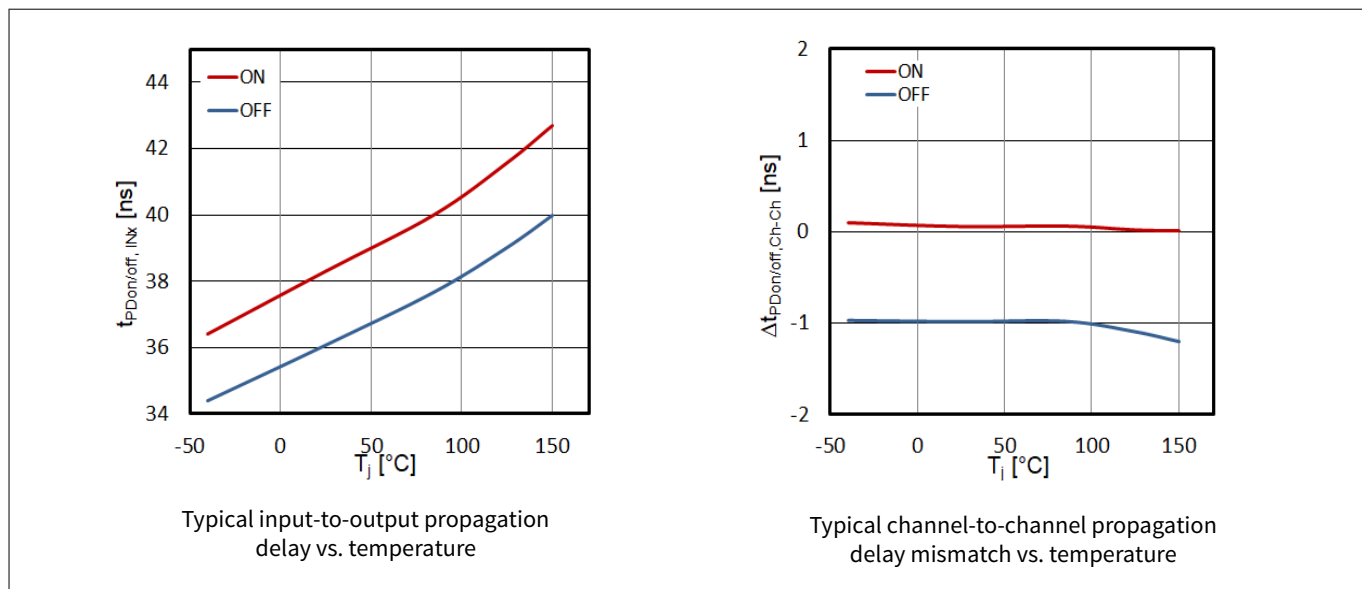

Figure 19 **Typical propagation delays**

5 Typical characteristics

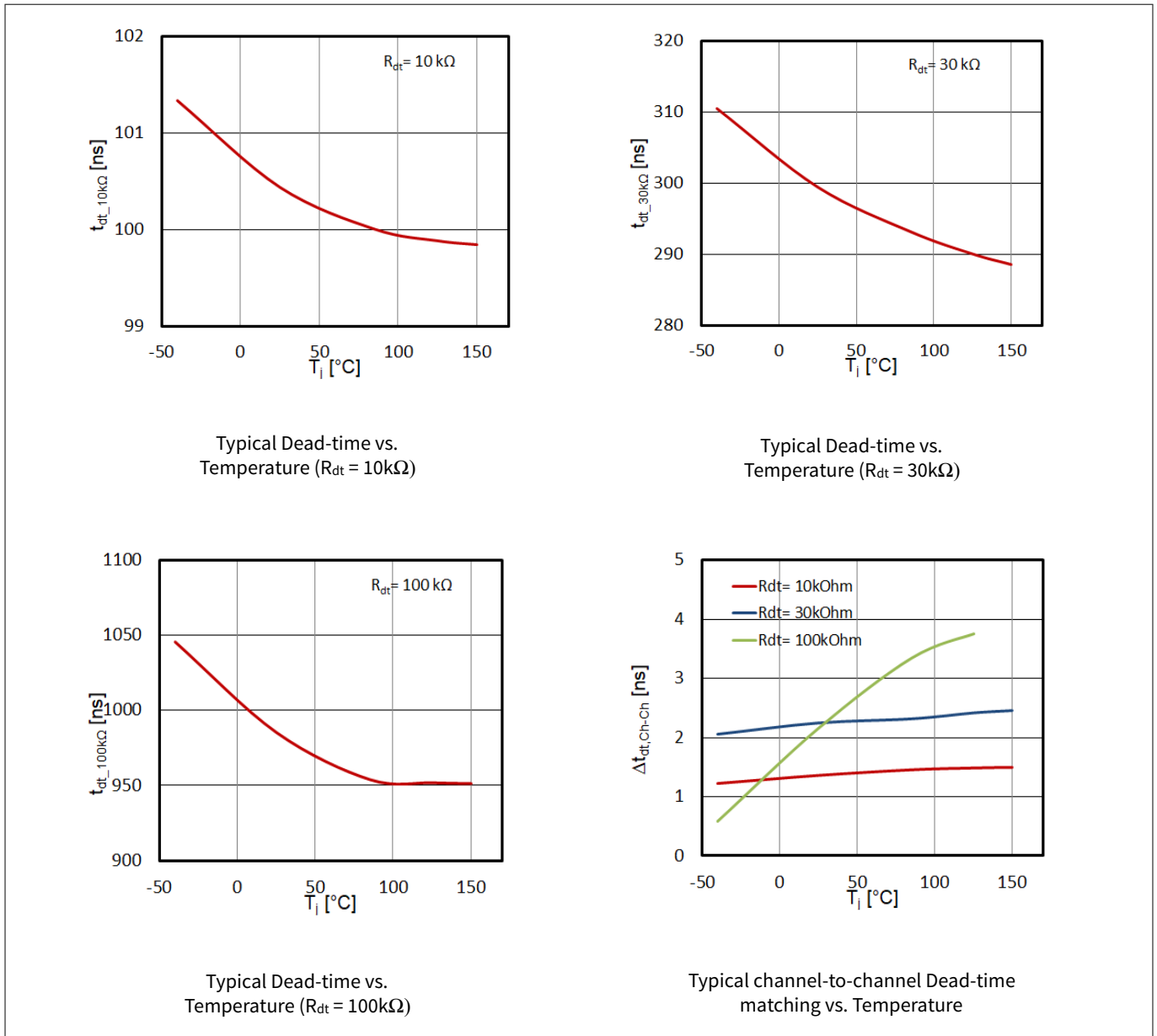

Figure 20 Typical Dead-time

5 Typical characteristics

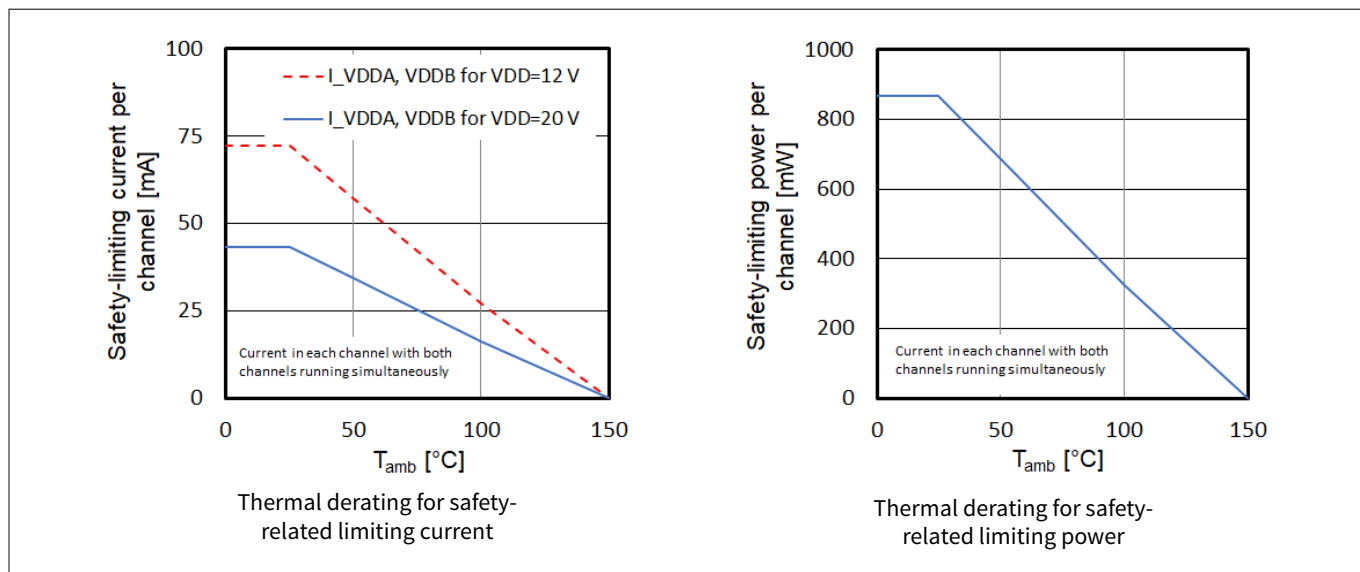

Figure 21 Thermal derating curves

6 Package outline dimensions

6 Package outline dimensions

6.1 Device numbers and markings

Table 27 Device numbers and markings

| Part number | Orderable part number (OPN) | Device marking |
|-------------|-----------------------------|----------------|
| 2EDR8259H | 2EDR8259HXUMA1 | 2R8259B |
| 2EDR7259X | 2EDR7259XXUMA1 | 2R7259B |
| 2EDR8259X | 2EDR8259XXUMA1 | 2R8259B |
| 2EDR9259X | 2EDR9259XXUMA1 | 2R9259B |
| 2EDR6258X | 2EDR6258XXUMA1 | 2R6258B |
| 2EDR8258X | 2EDR8258XXUMA1 | 2R8258B |
| 2EDR9258X | 2EDR9258XXUMA1 | 2R9258B |

6.2 Package DSO16-300mil

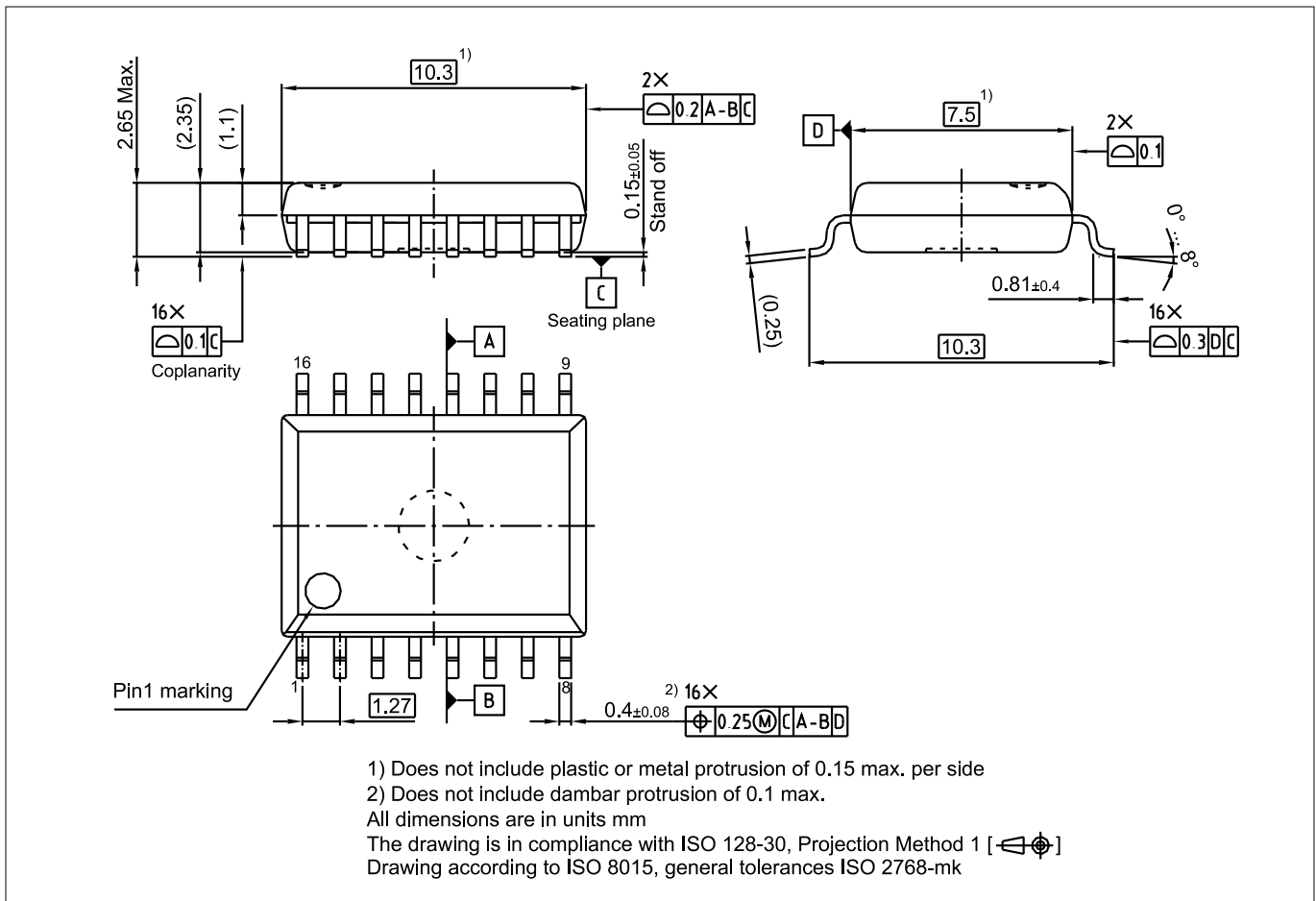

Figure 22 DSO16-300mil outline

6 Package outline dimensions

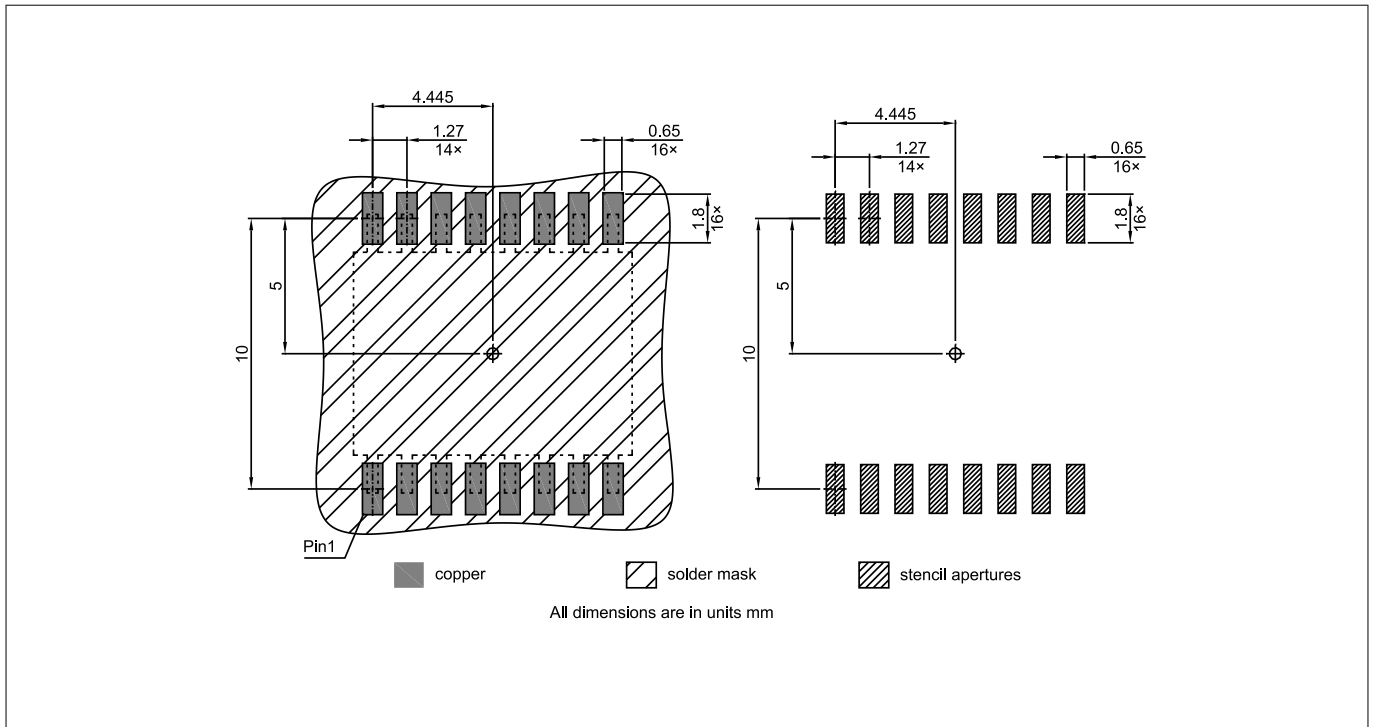

Figure 23 DSO16-300mil footprint

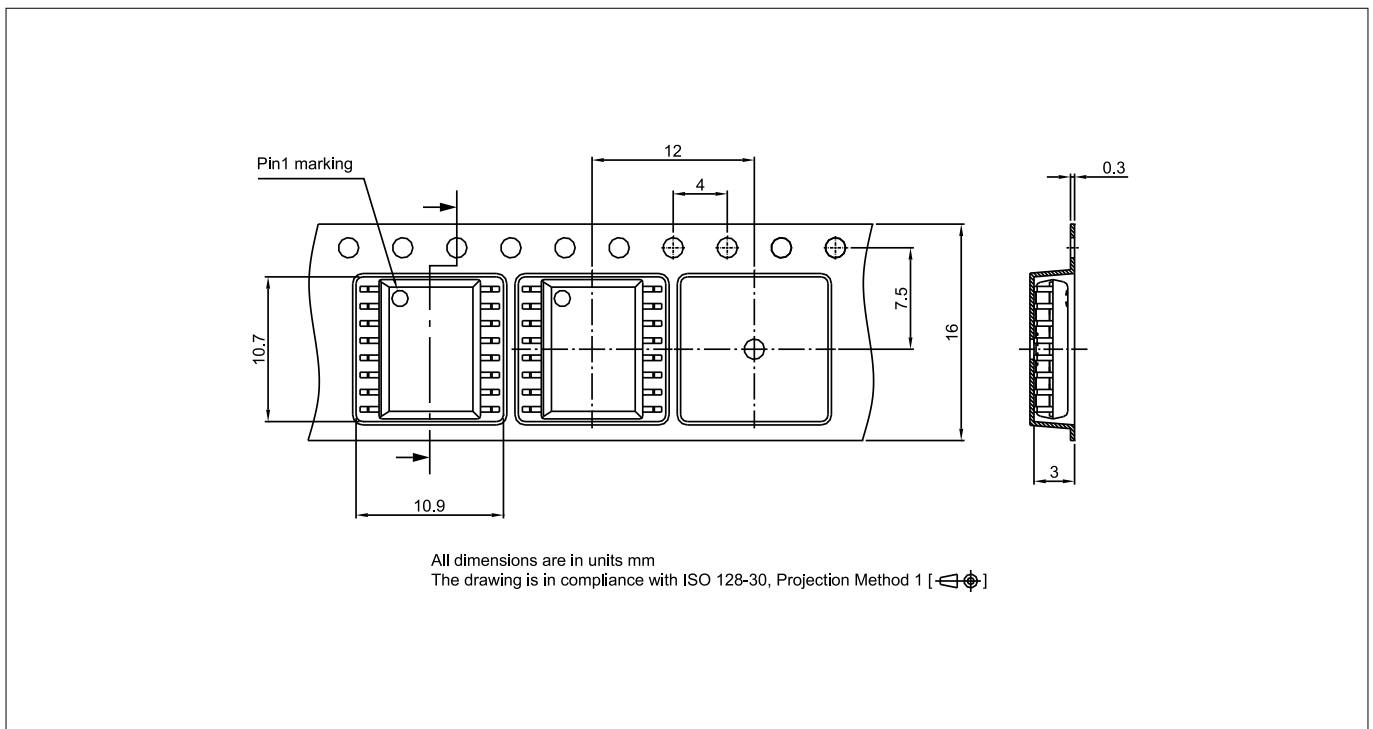

Figure 24 DSO16-300mil packing

Green Product (RoHS compliant)

To meet the worldwide customer requirements for environmentally friendly products and to be compliant with government regulations the device is available as a green product. Green products are RoHS-Compliant (i.e. Pb-free finish on leads and suitable for Pb-free soldering according to IPC/JEDEC J-STD-020). Further information on packages: <https://www.infineon.com/packages>

6 Package outline dimensions

6.3 Package DSO14-300mil

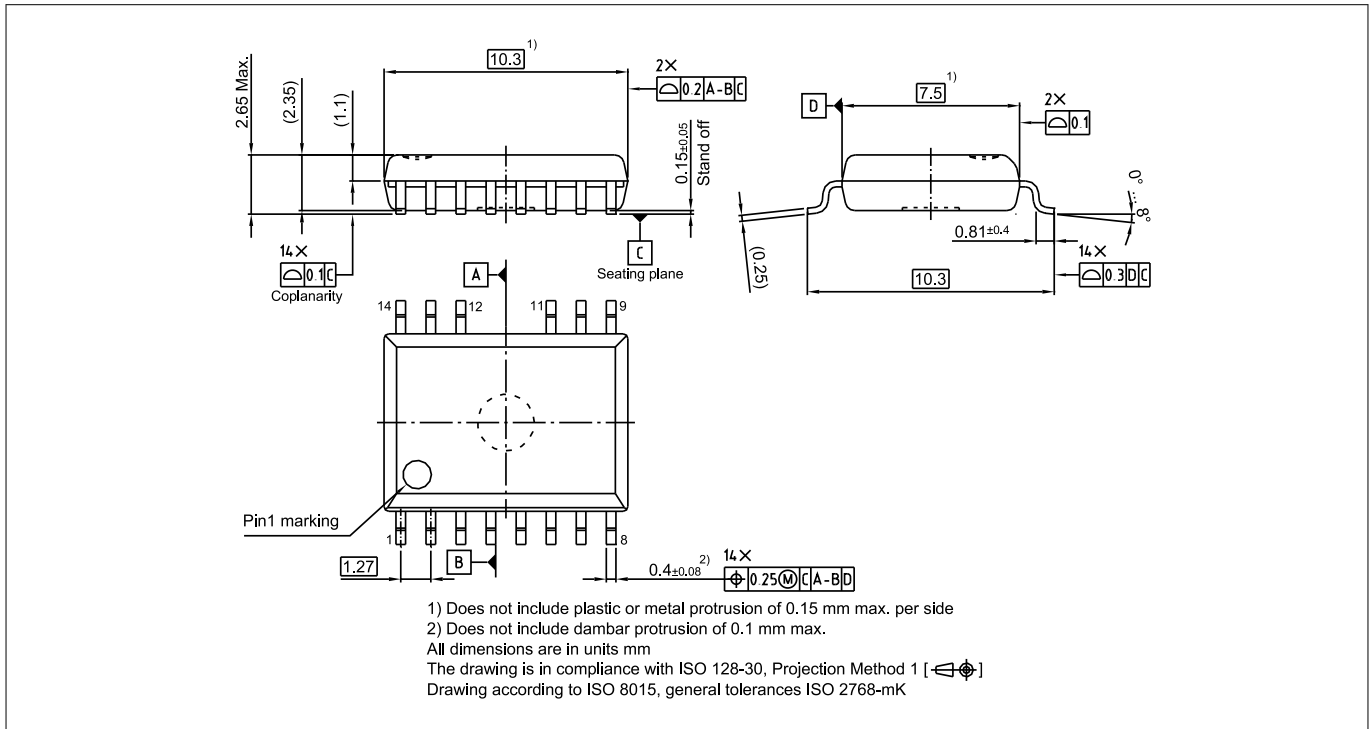

Figure 25 DSO14-300mil outline

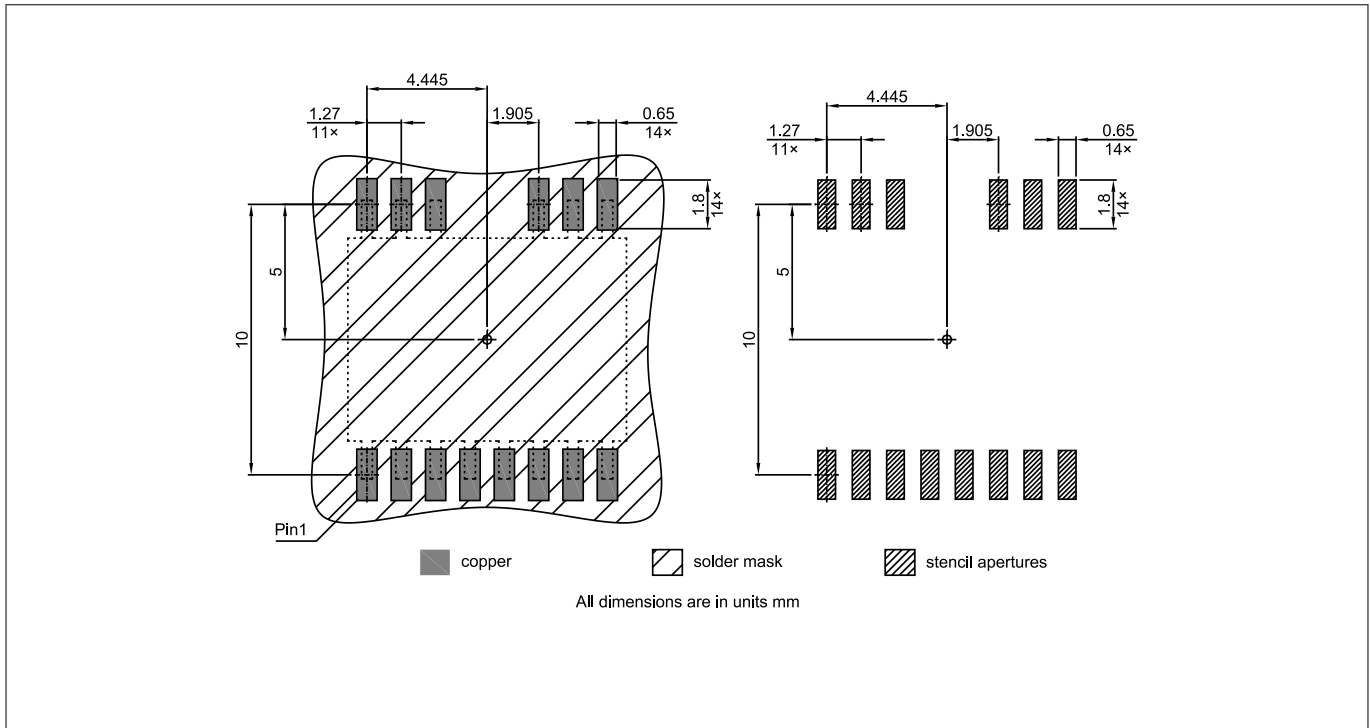

Figure 26 DSO14-300mil footprint

6 Package outline dimensions

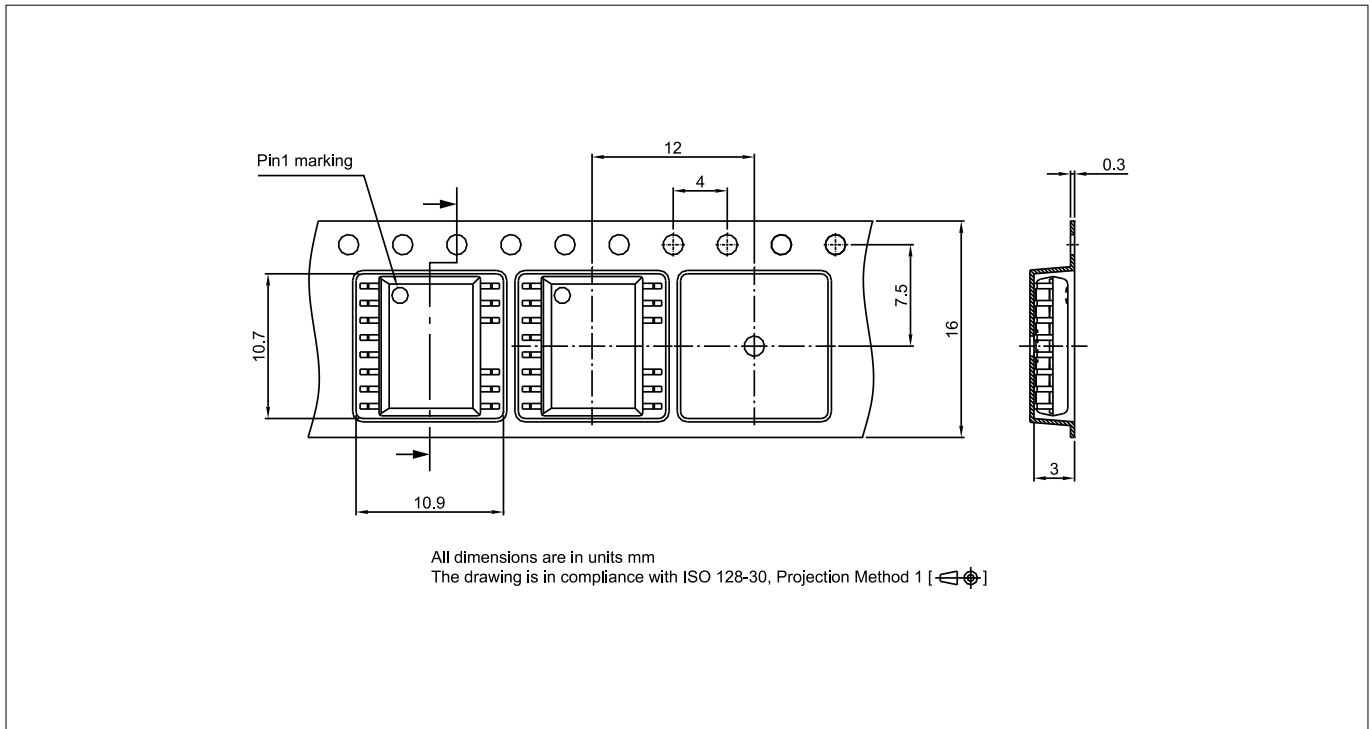

Figure 27 DSO14-300mil packing

Green Product (RoHS compliant)

To meet the worldwide customer requirements for environmentally friendly products and to be compliant with government regulations the device is available as a green product. Green products are RoHS-Compliant (i.e. Pb-free finish on leads and suitable for Pb-free soldering according to IPC/JEDEC J-STD-020). Further information on packages: <https://www.infineon.com/packages>

7 Revision history

7 Revision history

| Revision | Date | Description of changes |
|-----------------|-------------|---|
| Rev 1.6 | 2025-03-31 | <p>Updated STP/DTC feature description</p> <p>Updated footnote #3 in Table 24, added thermal shutdown parameters in Electrical characteristics table</p> <p>Modified features and updated safety certifications in cover page, added V_{IOWM} and modified note or condition for the R_{IO}, V_{IOTM} and q_{PD} in Table 24, added Thermal derating curves in Typical Characteristics section</p> <p>Added climatic category</p> <p>Added safety-limiting values in isolation specifications table</p> |
| Rev 1.5 | 2024-03-04 | <p>Updated device marking</p> <p>Updated typical characteristic curves</p> <p>Added CQC certification in cover page</p> <p>Updated ESD CDM rating</p> |
| Rev 1.4 | 2023-10-30 | Fixed typo in Table 11 : minimum T_A : 40°C → -40°C |
| Rev 1.3 | 2023-02-27 | <p>Added condition "DTC pin connected to ground"</p> <p>Fixed typo in the OPN of Table 27</p> |
| Rev 1.2 | 2023-01-19 | Fixed typo in channel-to-channel propagation delay mismatch |
| Rev 1.1 | 2022-12-12 | <p>Removed watermark "restricted"</p> <p>"Dead-time distortion" renamed as "Channel turn-off to channel turn-on propagation delay mismatch" in Table 21</p> |
| Rev 1.0 | 2022-12-09 | Initial release |

Trademarks

All referenced product or service names and trademarks are the property of their respective owners.

Edition 2025-03-31

Published by

Infineon Technologies AG

81726 Munich, Germany

© 2025 Infineon Technologies AG

All Rights Reserved.

Do you have a question about any aspect of this document?

Email: erratum@infineon.com

Document reference

IFX-jqf1648202404767

Important notice

The information given in this document shall in no event be regarded as a guarantee of conditions or characteristics ("Beschaffheitsgarantie").

With respect to any examples, hints or any typical values stated herein and/or any information regarding the application of the product, Infineon Technologies hereby disclaims any and all warranties and liabilities of any kind, including without limitation warranties of non-infringement of intellectual property rights of any third party.

In addition, any information given in this document is subject to customer's compliance with its obligations stated in this document and any applicable legal requirements, norms and standards concerning customer's products and any use of the product of Infineon Technologies in customer's applications.

The data contained in this document is exclusively intended for technically trained staff. It is the responsibility of customer's technical departments to evaluate the suitability of the product for the intended application and the completeness of the product information given in this document with respect to such application.

Warnings

Due to technical requirements products may contain dangerous substances. For information on the types in question please contact your nearest Infineon Technologies office.

Except as otherwise explicitly approved by Infineon Technologies in a written document signed by authorized representatives of Infineon Technologies, Infineon Technologies' products may not be used in any applications where a failure of the product or any consequences of the use thereof can reasonably be expected to result in personal injury.