

### 2ED314xMC12L (2ED-X3 Compact)

#### Dual-channel isolated gate driver IC with dead-time control

#### Features

- Dual-channel isolated gate driver
- To be used with 600 V/650 V/1200 V/1700 V/2300 V IGBTs, Si, and SiC MOSFETs
- Up to 6.5 A typical peak output current
- 39 ns propagation delay with 5 ns channel-to-channel delay mismatch (skew)
- 35 V absolute maximum output supply voltage
- High common-mode transient immunity, CMTI > 200 kV/μs
- Active shutdown and short circuit clamping
- Galvanically isolated coreless transformer gate driver
- 3.3 V and 5 V input supply voltage
- 8 mm input-to-output and 3.3 mm channel-to-channel creepage and clearance
- Safety certification
  - UL 1577 (File 311313) with  $V_{ISO, test} = 6840$  V (rms) for 1 s,  $V_{ISO} = 5700$  V (rms) for 60 s
  - Reinforced insulation according to IEC 60747-17 (Certificate no. 40055138) with  $V_{IORM} = 1767$  V (peak)



#### Potential applications

- EV charging
- Energy storage systems
- Solar inverters
- Server and telecom switched-mode power supplies (SMPS)
- UPS systems
- AC and brushless DC motor drives
- Commercial air conditioners (CAC)
- High voltage DC-DC converters and DC-AC inverters

#### Product validation

Qualified for industrial applications according to the relevant tests of JEDEC47/20/22.

#### Description

The EiceDRIVER™ 2ED314xMC12L is a family of dual-channel isolated gate driver ICs designed to drive Si MOSFETs, IGBTs, and SiC MOSFETs. All products are available in a 14-pin DSO package with 8 mm input-to-output creepage and provide reinforced isolation. All variants offer dead-time control (DTC) functionality and independent channel operation. This enables the operation as dual-channel low-side driver, dual-channel high-side driver or half-bridge gate driver with a configurable dead-time. With excellent common-mode transient immunity (CMTI), low part-to-part propagation delay mismatch, and fast signal propagation, these products are best suited for fast-switching applications.

### Description

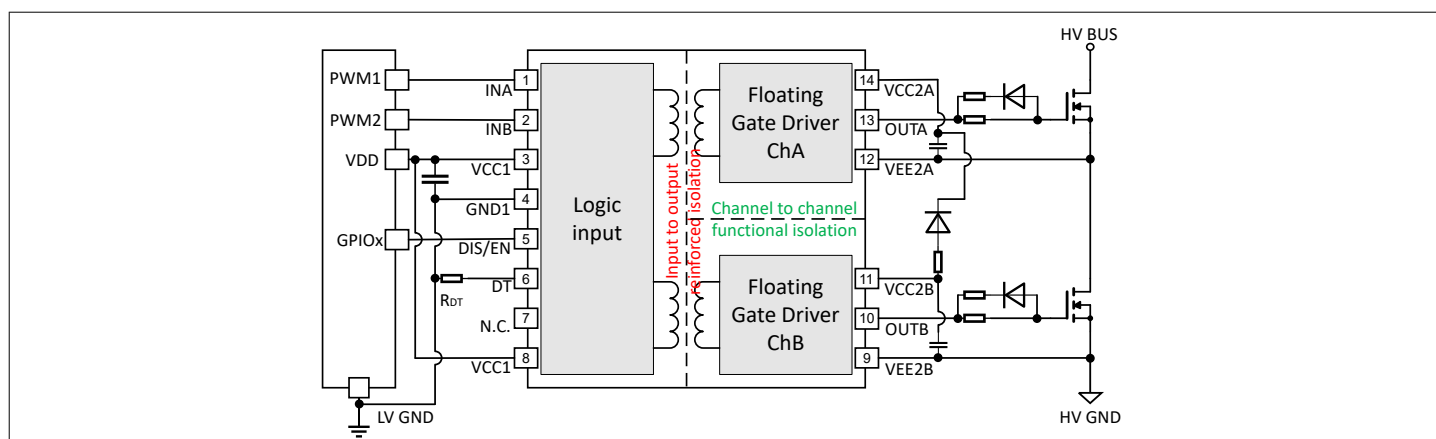

**Typical application diagram using bootstrap biasing**

**Table 1 Ordering information**

| Product type                 | Typical UVLO ( $V_{UVLOL2}/V_{UVLOH2}$ ) | Typical output current source/sink | Functionality | UL 1577 certification (single isolation) | IEC 60747-17 certification (reinforced isolation) | Package marking |
|------------------------------|--|------------------------------------|---------------|--|---|-----------------|
| <a href="#">2ED3140MC12L</a> | 8.5 V / 9.3 V                            | 6 A / 6.5 A                        | DISABLE       | E311313                                  | 40055138  | 2ED3140MC12     |
| <a href="#">2ED3141MC12L</a> | 11 V / 12 V                              | 6 A / 6.5 A                        | DISABLE       | E311313                                  | 40055138  | 2ED3141MC12     |
| <a href="#">2ED3142MC12L</a> | 12.5 V / 13.6 V                          | 6 A / 6.5 A                        | DISABLE       | E311313                                  | 40055138  | 2ED3142MC12     |
| <a href="#">2ED3143MC12L</a> | 14.7 V / 16 V                            | 6 A / 6.5 A                        | DISABLE       | E311313                                  | 40055138  | 2ED3143MC12     |
| <a href="#">2ED3144MC12L</a> | 8.5 V / 9.3 V                            | 6 A / 6.5 A                        | ENABLE        | E311313                                  | 40055138  | 2ED3144MC12     |
| <a href="#">2ED3145MC12L</a> | 11 V / 12 V                              | 6 A / 6.5 A                        | ENABLE        | E311313                                  | 40055138  | 2ED3145MC12     |
| <a href="#">2ED3146MC12L</a> | 12.5 V / 13.6 V                          | 6 A / 6.5 A                        | ENABLE        | E311313                                  | 40055138  | 2ED3146MC12     |
| <a href="#">2ED3147MC12L</a> | 14.7 V / 16 V                            | 6 A / 6.5 A                        | ENABLE        | E311313                                  | 40055138  | 2ED3147MC12     |

**Table 2 Related evaluation boards**

| Board name                            | Gate driver                  | Power transistor               | Short description   |
|---------------------------------------|------------------------------|--------------------------------|---|
| <a href="#">EVAL-2ED3146MC12L-SIC</a> | <a href="#">2ED3146MC12L</a> | <a href="#">IMZA120R020M1H</a> | Half-bridge board with the 2ED3146MC12L gate driver and paired with CoolSiC™ in a PG-TO-247-4 package |

## Table of contents

|          |  |    |
|----------|--|----|
|          | <b>Features</b> .....  | 1  |
|          | <b>Potential applications</b> .....  | 1  |
|          | <b>Product validation</b> .....  | 1  |
|          | <b>Description</b> .....   | 1  |
|          | <b>Table of contents</b> .....   | 3  |
| <b>1</b> | <b>Block diagram reference</b> .....   | 5  |
| <b>2</b> | <b>Pin configuration and description</b> .....                                     | 5  |
| <b>3</b> | <b>Electrical characteristics and parameters</b> .....                             | 7  |
| 3.1      | Absolute Maximum Ratings .....   | 7  |
| 3.2      | Recommended operating conditions .....   | 9  |
| 3.3      | Electrical characteristics .....   | 10 |
| 3.3.1    | Power supply .....   | 10 |
| 3.3.2    | Logic input .....  | 11 |
| 3.3.3    | Gate driver .....  | 11 |
| 3.3.4    | Dead-time and shoot-through protection .....                                       | 11 |
| 3.3.5    | Dynamic characteristics .....  | 12 |
| 3.3.6    | Active shut down .....   | 13 |
| 3.3.7    | Overtemperature protection .....   | 14 |
| <b>4</b> | <b>Insulation characteristics (IEC 60747-17, UL 1577) for DSO-14 package</b> ..... | 15 |
| <b>5</b> | <b>Typical characteristics</b> .....   | 16 |
| <b>6</b> | <b>Parameter measurement</b> .....   | 20 |
| 6.1      | CMTI measurement setup .....   | 20 |
| 6.2      | Undervoltage lockout (UVLO) .....  | 20 |
| 6.3      | Propagation delay, rise and fall time .....  | 21 |
| 6.4      | Deadtime matching, skew, and skew+ .....   | 22 |
| <b>7</b> | <b>Functional description</b> .....  | 24 |
| 7.1      | Input-side functional blocks .....   | 24 |
| 7.1.1    | Input supply undervoltage lockout (UVLO) .....                                     | 24 |
| 7.1.2    | Input signal filters .....   | 25 |
| 7.1.3    | Pull-down resistors .....  | 25 |
| 7.1.4    | Dead-time control .....  | 25 |
| 7.2      | Output-side functional blocks .....  | 27 |
| 7.2.1    | Output-side undervoltage lockout (UVLO) .....                                      | 27 |
| 7.2.2    | Short-circuit clamping .....   | 28 |
| 7.2.3    | Active shutdown .....  | 28 |
| 7.2.4    | Overtemperature protection .....   | 28 |

|           |                                      |    |
|-----------|--------------------------------------|----|
| <b>8</b>  | <b>Application information</b> ..... | 29 |
| 8.1       | Typical application .....            | 29 |
| 8.2       | Power supply recommendations .....   | 30 |
| 8.3       | Gate resistor selection .....        | 30 |
| 8.4       | Dead-time resistor selection .....   | 31 |
| 8.5       | Power dissipation estimation .....   | 31 |
| 8.5.1     | Gate driver .....                    | 31 |
| 8.5.2     | External gate resistor .....         | 32 |
| 8.6       | Layout guidelines .....              | 32 |
| <b>9</b>  | <b>Related products</b> .....        | 34 |
| <b>10</b> | <b>Package dimensions</b> .....      | 35 |
|           | <b>Revision history</b> .....        | 36 |
|           | <b>Disclaimer</b> .....              | 37 |

## 1 Block diagram reference

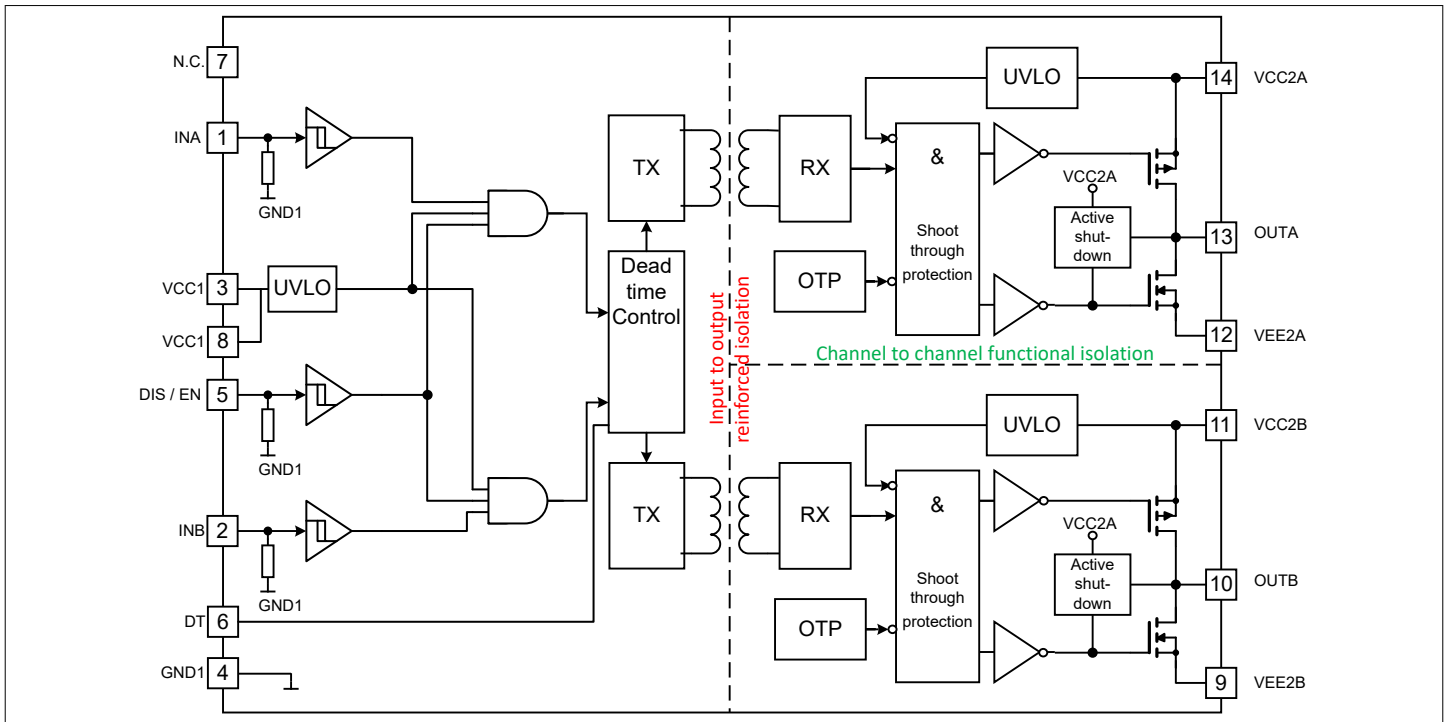

**Figure 2** Block diagram

## 2 Pin configuration and description

### Pin configuration

**Table 3** Pin configuration

| Pin No. | Name  | Function                                    |
|---------|-------|---|
| 1       | INA   | Input signal channel A                      |
| 2       | INB   | Input signal channel B                      |
| 3, 8    | VCC1  | Positive power supply input side            |
| 4       | GND1  | Ground reference input side                 |
| 5       | DIS   | DISABLE input channel A and B (high active) |
| 5       | EN    | ENABLE input channel A and B (high active)  |
| 6       | DT    | Dead-time control                           |
| 7       | N.C.  | No internal connection                      |
| 9       | VEE2B | Ground reference output channel B           |
| 10      | OUTB  | Gate driver output channel B                |
| 11      | VCC2B | Positive power supply output channel B      |
| 12      | VEE2A | Ground reference output channel A           |
| 13      | OUTA  | Gate driver output channel A                |
| 14      | VCC2A | Positive power supply output channel A      |

**2 Pin configuration and description**

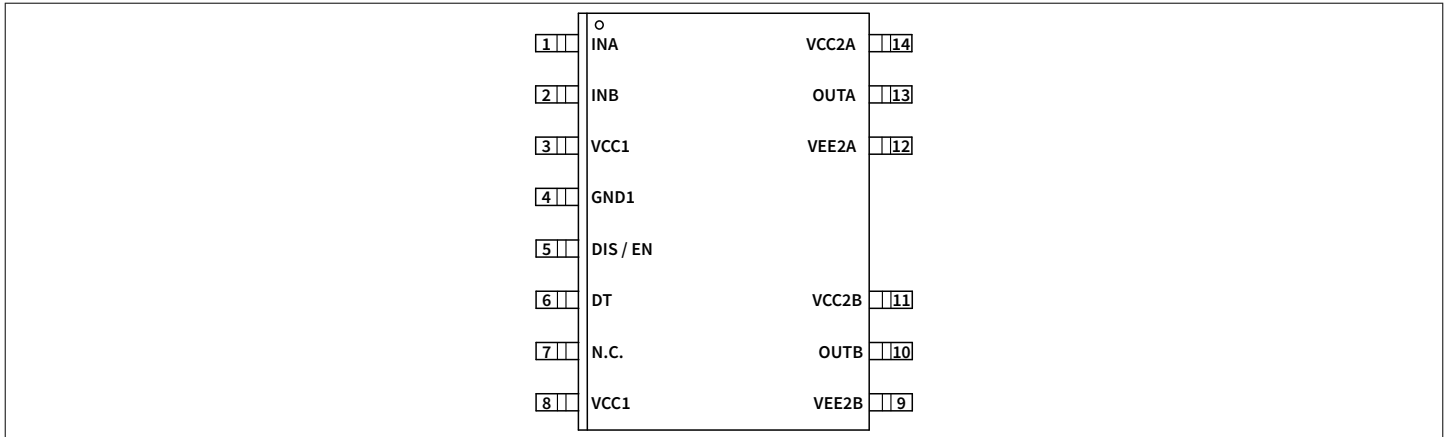

**Figure 3 DSO-14-71 (top view)**

**Pin description**

- **VCC1**: Input supply voltage. Connect to 3.3 V or 5 V and decouple with a capacitor to **GND1**. Use a low ESR and ESL capacitor which is placed as close as possible to the device
- **GND1**: Input ground. All the input side signals, **VCC1**, **IN+** and **IN-** are referenced to this ground
- **INA**: Non-inverted control signal for output channel A. An internal filter provides robustness against noise at **INA**
- **INB**: Non-inverted control signal for output channel B. An internal filter provides robustness against noise at **INB**
- **DIS** (2ED3140-2ED3143): Disable input pin. At logic high, it switches **OUTA** and **OUTB** off, at logic low the output levels are controlled by their individual input pins
- **EN** (2ED3144-2ED3147): Enable input pin. At low, it switches **OUTA** and **OUTB** off, at logic high the output levels are controlled by their individual input pins
- **DT**: Dead-time control. The feature is active if the pin is connected to **GND1** via a resistor, inactive if tied to **VCC1** or left open. Connecting capacitive loads to this pin is not recommended. The configured dead-time should be reasonably smaller than the minimum pulse width
- **VCC2A**: Channel A positive power supply rail. Connect a decoupling capacitor from this pin to **VEE2A**. Use low ESR and ESL capacitors which are placed as close as possible to the device
- **VEE2A**: Channel A output ground. **VCC2A** and **OUTA** are referenced to this ground. In case of a bipolar supply (positive and negative voltage referred to the IGBT emitter or MOSFET source), this pin should be connected to the negative supply voltage
- **OUTA**: Channel A output pin used to charge and discharge the gate of the external transistor (IGBT or MOSFET). During the on-state this output is connected to **VCC2A** and during the off-state to **VEE2A**. This output is controlled by **INA** and is turned off by an UVLO or OTP event
- **VCC2B**: Channel B positive power supply rail. Connect a decoupling capacitor from this pin to **VEE2B**. Use low ESR and ESL capacitors which are placed as close as possible to the device
- **VEE2B**: Channel B output ground. **VCC2B** and **OUTB** are referenced to this ground. In case of a bipolar supply (positive and negative voltage referred to the IGBT emitter or MOSFET source), this pin should be connected to the negative supply voltage
- **OUTB**: Channel B output pin used to charge and discharge the gate of the external transistor (IGBT or MOSFET). During the on-state this output is connected to **VCC2A** and during the off-state to **VEE2B**. This output is controlled by **INB** and is turned off by an UVLO or OTP event

### 3 Electrical characteristics and parameters

#### 3.1 Absolute Maximum Ratings

**Table 4 Absolute Maximum Ratings**

Stresses beyond those listed under *absolute maximum ratings* may cause permanent damage to the device. These are stress ratings only. Operating the device at these or any other conditions beyond those indicated under *recommended operating conditions* is not implied. Device reliability may be affected by exposure to absolute-maximum-rated conditions for extended periods of time.

| Parameter                                       | Symbol          | Values              |      |                     | Unit | Note or condition                                     |
|---|-----------------|---------------------|------|---------------------|------|---|
|   |                 | Min.                | Typ. | Max.                |      |   |
| Power supply input side voltage                 | $V_{VCC1}$      | -0.3                |      | 17                  | V    | $V_{VCC1} - V_{GND1}$                                 |
| Power supply output side voltage                | $V_{VCC2}$      | -0.3                |      | 35                  | V    | $V_{VCC2A} - V_{VEE2A}, V_{VCC2B} - V_{VEE2B}$        |
| Gate driver output voltage                      | $V_{OUT}$       | $V_{VEE2A/B} - 0.3$ |      | $V_{VCC2A/B} + 0.3$ | V    |   |
| Logic input voltages (INA, INB, DIS/EN)         | $V_{IN}$        | -0.3                |      | 17                  | V    |   |
| Dynamic logic input voltages (INA, INB, DIS/EN) | $V_{INDyn}$     | -5                  |      | 17                  | V    | <sup>1)</sup> $t_{IN} < 50$ ns                        |
| Dead time control (DT)                          | $V_{DT}$        | -0.3                |      | $V_{VCC1} + 0.3$    | V    |   |
| Input to output offset voltage                  | $V_{OFFSET}$    |                     |      | 2300                | V    | <sup>2)</sup> $V_{OFFSET} =  V_{VEE2A/B} - V_{GND1} $ |
| Channel-to-channel isolation voltage            | $V_{Ch-Ch}$     |                     |      | 1850                | V    | <sup>1)</sup> $ V_{VEE1} - V_{VEE2} $                 |
| ESD robustness - human body model               | $ V_{ESD,HBM} $ |                     |      | 2                   | kV   | <sup>3)</sup>   |
| ESD robustness - charged device model           | $ESD,CDM$       |                     |      | TC1000              |      | <sup>4)</sup>   |
| Junction temperature                            | $T_J$           | -40                 |      | 150                 | °C   |   |
| Storage temperature                             | $T_{Stg}$       | -65                 |      | 150                 | °C   |   |

#### PG-DSO-14-71 Thermal characteristics

|  |              |  |    |     |     |   |
|--|--------------|--|----|-----|-----|---|
| Power dissipation (input side)         | $P_{D,IN}$   |  |    | 66  | mW  | <sup>5)</sup> $T_A = 85$ °C   |
| Power dissipation (output side)        | $P_{D,OUT}$  |  |    | 900 | mW  | <sup>6) 7)</sup> $T_A = 85$ °C, equally distribute to the output channels |
| Thermal resistance junction-case (top) | $R_{thJC}$   |  | 46 |     | K/W |   |
| Thermal resistance junction ambient    | $R_{thJA25}$ |  | 69 |     | K/W | <sup>8)</sup> $T_A = 25$ °C, 2s2p - no vias, $P_D = 900$ mW               |
| Thermal resistance junction ambient    | $R_{thJA85}$ |  | 65 |     | K/W | <sup>8)</sup> $T_A = 85$ °C, 2s2p - no vias, $P_D = 900$ mW               |
| Thermal resistance junction board      | $R_{thJB}$   |  | 27 |     | K/W | <sup>9)</sup> $T_A = 85$ °C, 2s2p - no vias, $P_D = 450$ mW               |

(table continues...)

**Table 4 (continued) Absolute Maximum Ratings**

Stresses beyond those listed under *absolute maximum ratings* may cause permanent damage to the device. These are stress ratings only. Operating the device at these or any other conditions beyond those indicated under *recommended operating conditions* is not implied. Device reliability may be affected by exposure to absolute-maximum-rated conditions for extended periods of time.

| Parameter                                 | Symbol          | Values |      |      | Unit | Note or condition                   |
|---|-----------------|--------|------|------|------|-------------------------------------|
|   |                 | Min.   | Typ. | Max. |      |                                     |
| Characterization parameter junction-top   | $\Psi_{thJT}$   |        | 12   |      | K/W  | <sup>10)</sup>                      |
| Characterization parameter junction-board | $\Psi_{thJB25}$ |        | 23   |      | K/W  | <sup>10)</sup> $T_A = 25\text{ °C}$ |

- 1) Parameter is not subject to production test - verified by design/characterization
- 2) for functional operation only
- 3) According to ANSI/ESDA/JEDEC-JS-001-2017 (discharging a 100 pF capacitor through a 1.5 k $\Omega$  series resistor).
- 4) According to ANSI/ESDA/JEDEC-JS-002-2014 (TC = test condition in volt)
- 5) IC input-side power dissipation is derated linearly with 14 mW/°C above 145 °C
- 6) IC output-side power dissipation is derated linearly with 14 mW/°C above 85 °C
- 7) For both channels in total
- 8) 2s2p high-K board, as specified in JESD51-7, in an environment described in JESD51-2
- 9) 2s2p high-K board, as specified in JESD51-7, in an environment described in JESD51-8 with a ring cold plate fixture to control the PCB temperature
- 10) Estimates the junction temperature of a device in a real system and is extracted from the simulation data for obtaining Rth, using a procedure described in JESD51-2a (sections 6 and 7)

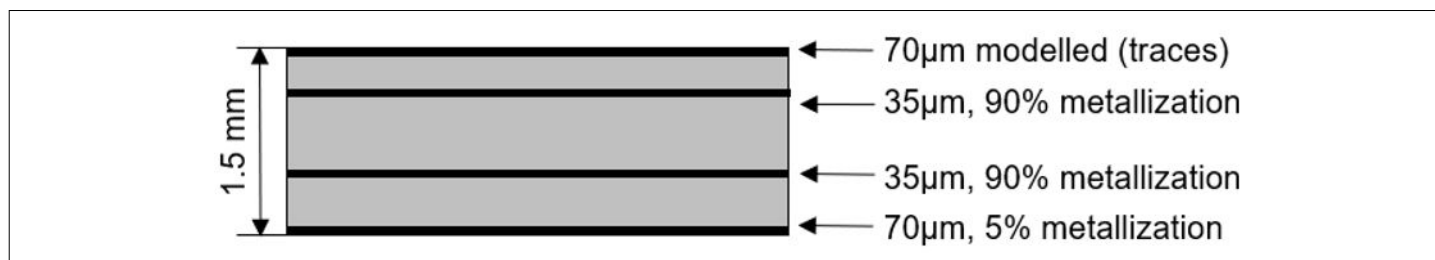
**Figure 4 PCB layer stack for thermal simulations**

This PCB layout represents the reference layout used for the thermal characterization.

## 3.2 Recommended operating conditions

**Table 5 Recommended operating conditions**

| Parameter                               | Symbol     | Values |      |            | Unit | Note or condition                               |
|---|------------|--------|------|------------|------|---|
|   |            | Min.   | Typ. | Max.       |      |   |
| Power supply input side voltage         | $V_{VCC1}$ | 3      |      | 16.5       | V    | $V_{VCC1} - V_{GND1}$                           |
| Power supply output side voltage        | $V_{VCC2}$ | 9.6    |      | 32         | V    | $V_{VCC2A/B} - V_{VEE2A/B}$ , 2ED3140 & 2ED3144 |
| Power supply output side voltage        | $V_{VCC2}$ | 12.35  |      | 32         | V    | $V_{VCC2A/B} - V_{VEE2A/B}$ , 2ED3141 & 2ED3145 |
| Power supply output side voltage        | $V_{VCC2}$ | 14     |      | 32         | V    | $V_{VCC2A/B} - V_{VEE2A/B}$ , 2ED3142 & 2ED3146 |
| Power supply output side voltage        | $V_{VCC2}$ | 16.45  |      | 32         | V    | $V_{VCC2A/B} - V_{VEE2A/B}$ , 2ED3143 & 2ED3147 |
| Logic input voltages (INA, INB, DIS/EN) | $V_{IN}$   | 0      |      | 5.5        | V    |   |
| Dead time control (DT)                  | $V_{DT}$   | 0      |      | $V_{VCC1}$ | V    |   |
| Ambient temperature                     | $T_A$      | -40    |      | 125        | °C   | –   |
| Junction temperature                    | $T_J$      | -40    |      | 150        | °C   | –   |

### 3.3 Electrical characteristics

The electrical characteristics include the spread of values over supply voltages and temperatures within the recommended operating conditions. Electrical characteristics are tested in production at  $T_A = 25\text{ °C}$ . Typical values represent the median values measured at  $V_{VCC1} = 3.3\text{ V}$ ,  $V_{VCC2A/B} - V_{VEE2A/B} = 15\text{ V}$ , and  $T_A = 25\text{ °C}$ . Minimum and maximum values in characteristics are verified by characterization/design. This is valid for all electrical characteristics unless specified otherwise.

#### 3.3.1 Power supply

Table 6 Power supply

| Parameter                                | Symbol       | Values |       |       | Unit | Note or condition   |
|--|--------------|--------|-------|-------|------|---|
|  |              | Min.   | Typ.  | Max.  |      |   |
| UVLO threshold input side (on)           | $V_{UVLOH1}$ |        | 2.85  | 3     | V    | $V_{VCC1} - V_{GND1}$   |
| UVLO threshold input side (off)          | $V_{UVLOL1}$ | 2.55   | 2.7   |       | V    | $V_{VCC1} - V_{GND1}$   |
| UVLO hysteresis input side               | $V_{HYS1}$   | 0.1    | 0.15  | 0.2   | V    | $V_{UVLOH1} - V_{UVLOL1}$   |
| Quiescent current input side             | $I_{Q1}$     |        | 1.67  | 2.12  | mA   | INA = Low, INB = Low, DT = VCC1   |
| Quiescent current output side, ON state  | $I_{Q2,ON}$  |        |       | 1.35  | mA   | <sup>1)</sup> INA = High, INB = Low or INA = Low, INB = High, $V_{VCC2A/B} - V_{VEE2A/B} < 18\text{ V}$ |
| Quiescent current output side, OFF state | $I_{Q2,OFF}$ |        |       | 1.0   | mA   | <sup>1)</sup> INA = Low, INB = Low, $V_{VCC2A/B} - V_{VEE2A/B} < 18\text{ V}$                           |
| <b>2ED3140 / 2ED3144</b>                 |              |        |       |       |      |   |
| UVLO threshold output side (on)          | $V_{UVLOH2}$ |        | 9.3   | 9.6   | V    | $V_{VCC2A/B} - V_{VEE2A/B}$   |
| UVLO threshold output side (off)         | $V_{UVLOL2}$ | 8.25   | 8.55  |       | V    | $V_{VCC2A/B} - V_{VEE2A/B}$   |
| UVLO hysteresis output side              | $V_{HYS2}$   |        | 0.75  |       | V    | $V_{UVLOH2} - V_{UVLOL2}$   |
| <b>2ED3141 / 2ED3145</b>                 |              |        |       |       |      |   |
| UVLO threshold output side (on)          | $V_{UVLOH2}$ |        | 12    | 12.35 | V    | $V_{VCC2A/B} - V_{VEE2A/B}$   |
| UVLO threshold output side (off)         | $V_{UVLOL2}$ | 10.7   | 11.05 |       | V    | $V_{VCC2A/B} - V_{VEE2A/B}$   |
| UVLO hysteresis output side              | $V_{HYS2}$   |        | 0.95  |       | V    | $V_{UVLOH2} - V_{UVLOL2}$   |
| <b>2ED3142 / 2ED3146</b>                 |              |        |       |       |      |   |
| UVLO threshold output side (on)          | $V_{UVLOH2}$ |        | 13.6  | 14    | V    | $V_{VCC2A/B} - V_{VEE2A/B}$   |
| UVLO threshold output side (off)         | $V_{UVLOL2}$ | 12.15  | 12.55 |       | V    | $V_{VCC2A/B} - V_{VEE2A/B}$   |
| UVLO hysteresis output side              | $V_{HYS2}$   |        | 1.05  |       | V    | $V_{UVLOH2} - V_{UVLOL2}$   |
| <b>2ED3143 / 2ED3147</b>                 |              |        |       |       |      |   |
| UVLO threshold output side (on)          | $V_{UVLOH2}$ |        | 16    | 16.45 | V    | $V_{VCC2A/B} - V_{VEE2A/B}$   |
| UVLO threshold output side (off)         | $V_{UVLOL2}$ | 14.30  | 14.75 |       | V    | $V_{VCC2A/B} - V_{VEE2A/B}$   |
| UVLO hysteresis output side              | $V_{HYS2}$   |        | 1.25  |       | V    | $V_{UVLOH2} - V_{UVLOL2}$   |

1) Per channel

### 3.3.2 Logic input

**Table 7** Logic input

| Parameter                                       | Symbol       | Values |      |      | Unit       | Note or condition                        |
|---|--------------|--------|------|------|------------|--|
|   |              | Min.   | Typ. | Max. |            |  |
| INA,INB, DIS / EN low input threshold voltage   | $V_{IN,L}$   | 0.9    | 1.2  | 1.6  | V          |  |
| INA, INB, DIS / EN high input threshold voltage | $V_{IN,H}$   | 1.73   | 2.0  | 2.36 | V          |  |
| INA, INB, DIS / EN low/high hysteresis          | $V_{IN,HYS}$ | 0.38   | 0.8  | 1.2  | V          |  |
| INA, INB, DIS / EN input current                | $I_{IN}$     |        | 22   | 27   | $\mu A$    | $V_{VCC1} = 3.3 V, V_{IN} \leq V_{VCC1}$ |
| INA, INB, DIS / EN pull down resistor           | $R_{IN,PD}$  |        | 150  |      | k $\Omega$ | -  |

### 3.3.3 Gate driver

**Table 8** Gate driver

| Parameter  | Symbol          | Values |      |      | Unit     | Note or condition   |
|--|-----------------|--------|------|------|----------|---|
|  |                 | Min.   | Typ. | Max. |          |   |
| High level output peak current                         | $I_{OUTH}$      | 3.5    | 6    |      | A        | <sup>1)</sup> $V_{VCC2A/B} - V_{VEE2A/B} = 15 V, I_{NA/B} = High, C_L = 100 nF$ |
| High level output on resistance                        | $R_{DSON,H}$    | 0.3    | 0.9  | 2.2  | $\Omega$ | $I_{OUTH} = 0.1 A$  |
| Low level output peak current                          | $I_{OUTL}$      | 3.5    | 6.5  |      | A        | <sup>1)</sup> $V_{VCC2A/B} - V_{VEE2A/B} = 15 V, I_{NA/B} = Low, C_L = 100 nF$  |
| Low level output on resistance                         | $R_{DSON,L}$    | 0.2    | 0.5  | 1.1  | $\Omega$ | $I_{OUTL} = 0.1 A$  |
| Short circuit clamp voltage between OUTA/B and VCC2A/B | $V_{CLP\_OUTH}$ |        |      | 1.0  | V        | $V_{OUTA/B} - V_{VCC2A/B}, I_{OUTA/B} = -500 mA, t < 10 \mu s, I_{NA/B} = High$ |
| Clamp voltage between VEE2A/B and OUTA/B               | $V_{CLP\_OUTL}$ |        |      | 1.0  | V        | $V_{VEE2A/B} - V_{OUTA/B}, I_{OUTA/B} = -500 mA, t < 10 \mu s, I_{NA/B} = Low$  |

<sup>1)</sup> Parameter is not subject to production test - verified by design/characterization

### 3.3.4 Dead-time and shoot-through protection

**Table 9** Dead-time and shoot-through protection

| Parameter                         | Symbol      | Values |      |      | Unit              | Note or condition  |
|-----------------------------------|-------------|--------|------|------|-------------------|--|
|                                   |             | Min.   | Typ. | Max. |                   |  |
| Dead-time                         | $t_{DT}$    | 85     | 100  | 115  | ns                | <sup>1)</sup> $R_{DT} = 10 k\Omega$  |
| Dead-time                         | $t_{DT}$    | 255    | 300  | 345  | ns                | <sup>1)</sup> $R_{DT} = 30 k\Omega$  |
| Dead-time                         | $t_{DT}$    | 800    | 950  | 1100 | ns                | <sup>1) 2)</sup> $R_{DT} = 100 k\Omega$  |
| Dead-time to resistor value ratio | $K_{DT\_R}$ | 8      | 10   | 12   | ns/<br>k $\Omega$ | $1.2k\Omega \leq R_{DT} \leq 100k\Omega, t_{DT} = K_{DT\_R} \times R_{DT} + M_{DT\_R}$ |

(table continues...)

**Table 9 (continued) Dead-time and shoot-through protection**

| Parameter                       | Symbol                | Values |      |      | Unit       | Note or condition  |
|---------------------------------|-----------------------|--------|------|------|------------|--|
|                                 |                       | Min.   | Typ. | Max. |            |  |
| Dead-time offset                | $M_{DT\_R}$           |        | 0    |      | ns         | $t_{DT} = K_{DT\_R} \times R_{DT} + M_{DT\_R}$   |
| Dead-time resistor range        | $R_{DT}$              | 1.2    |      | 100  | k $\Omega$ |  |
| Ch-to-ch dead-time matching     | $\Delta t_{DT,Ch-Ch}$ |        |      | 10   | ns         | $R_{DT} = 10 \text{ k}\Omega$ , $\Delta t_{DT,Ch-Ch} =  t_{DT,A-B} - t_{DT,B-A} $                |
| Ch-to-ch dead-time matching     | $\Delta t_{DT,Ch-Ch}$ |        |      | 14   | ns         | $R_{DT} = 30 \text{ k}\Omega$ , $\Delta t_{DT,Ch-Ch} =  t_{DT,A-B} - t_{DT,B-A} $                |
| Ch-to-ch dead-time matching     | $\Delta t_{DT,Ch-Ch}$ |        |      | 40   | ns         | <sup>2)</sup> $R_{DT} = 100 \text{ k}\Omega$ , $\Delta t_{DT,Ch-Ch} =  t_{DT,A-B} - t_{DT,B-A} $ |
| Part-to-part dead-time matching | $\Delta t_{DT,P-P}$   |        |      | 20   | ns         | $R_{DT} = 10 \text{ k}\Omega$  |
| Part-to-part dead-time matching | $\Delta t_{DT,P-P}$   |        |      | 55   | ns         | $R_{DT} = 30 \text{ k}\Omega$  |
| Part-to-part dead-time matching | $\Delta t_{DT,P-P}$   |        |      | 105  | ns         | <sup>2)</sup> $R_{DT} = 100 \text{ k}\Omega$   |

1) Input filter time not included

2) Parameter is not subject to production test - verified by design/characterization

### 3.3.5 Dynamic characteristics

**Table 10 Dynamic characteristics**

| Parameter   | Symbol                | Values |      |      | Unit | Note or condition  |
|---|-----------------------|--------|------|------|------|--|
|   |                       | Min.   | Typ. | Max. |      |  |
| Input to output propagation delay ON              | $t_{PDON}$            | 30     | 39   | 50   | ns   | $V_{CC2A/B} - V_{VEE2A/B} = 15 \text{ V}$ , $C_L = 100 \text{ pF}$ , valid for INA, INB and DIS/EN, $V_{DT} = V_{CC1}$ |
| Input to output propagation delay OFF             | $t_{PDOFF}$           | 30     | 39   | 50   | ns   | $V_{CC2A/B} - V_{VEE2A/B} = 15 \text{ V}$ , $C_L = 100 \text{ pF}$ , valid for INA, INB and DIS/EN, $V_{DT} = V_{CC1}$ |
| Input to output propagation delay distortion      | $ t_{PDISTO} $        |        | 0    | 5    | ns   | <sup>1)</sup> $ t_{PDOFF} - t_{PDON} $   |
| Input to output, part to part turn-on skew        | $t_{SKEW\_ON,P-P}$    |        |      | 6    | ns   | <sup>1)</sup> $C_L = 100 \text{ pF}$ , $V_{DT} = V_{CC1}$  |
| Input to output, part to part turn-off skew       | $t_{SKEW\_OFF,P-P}$   |        |      | 8    | ns   | <sup>1)</sup> $C_L = 100 \text{ pF}$ , $V_{DT} = V_{CC1}$  |
| Input to output, channel to channel turn-on skew  | $t_{SKEW\_ON,Ch-Ch}$  |        |      | 5    | ns   | $V_{DT} = V_{CC1}$ , $t_{SKEW\_ON,Ch-Ch} =  t_{PDON,A} - t_{PDON,B} $  |
| Input to output, channel to channel turn-off skew | $t_{SKEW\_OFF,Ch-Ch}$ |        |      | 5    | ns   | $V_{DT} = V_{CC1}$ ; $t_{SKEW\_OFF,Ch-Ch} =  t_{PDOFF,A} - t_{PDOFF,B} $   |
| Input pulse suppression time (filter time)        | $t_{INFLT}$           | 10     | 17   | 25   | ns   | <sup>2)</sup>  |
| Input to output, channel to channel skew plus     | $t_{SKEW+}$           |        |      | 5    | ns   | $\max\{ t_{PDOFF,A} - t_{PDON,B} ,  t_{PDOFF,B} - t_{PDON,A} \}$ , $V_{DT} = V_{CC1}$                                  |

**(table continues...)**

**Table 10** (continued) **Dynamic characteristics**

| Parameter                                 | Symbol           | Values |      |      | Unit              | Note or condition   |
|---|------------------|--------|------|------|-------------------|---|
|   |                  | Min.   | Typ. | Max. |                   |   |
| Rise time                                 | $t_{RISE}$       |        |      | 20   | ns                | $V_{VCC2A/B} - V_{VEE2A/B} = 15\text{ V}$ , $C_L = 1\text{ nF}$ , valid for all parts, except 2ED3143 and 2ED3147 |
| Rise time                                 | $t_{RISE}$       |        |      | 20   | ns                | $V_{VCC2A/B} - V_{VEE2A/B} = 18\text{ V}$ , $C_L = 1\text{ nF}$ , valid for 2ED3143 and 2ED3147                   |
| Fall time                                 | $t_{FALL}$       |        |      | 20   | ns                | $V_{VCC2A/B} - V_{VEE2A/B} = 15\text{ V}$ , $C_L = 1\text{ nF}$ , valid for all parts, except 2ED3143 and 2ED3147 |
| Fall time                                 | $t_{FALL}$       |        |      | 20   | ns                | $V_{VCC2A/B} - V_{VEE2A/B} = 18\text{ V}$ , $C_L = 1\text{ nF}$ , valid for 2ED3143 and 2ED3147                   |
| Input-side start-up time                  | $t_{START,VCC1}$ |        | 3.5  | 5    | $\mu\text{s}$     | <sup>3)</sup> INA/B = High, DT = VCC1, DIS = low / EN = high, $V_{VCC2A/B} > V_{UVLOH2}$ , $C_L = 100\text{ pF}$  |
| Input-side deactivation time              | $t_{STOP,VCC1}$  | 600    | 750  |      | ns                | <sup>3)</sup> INA/B = High, DT = VCC1, DIS = low / EN = high, $V_{VCC2A/B} > V_{UVLOH2}$ , $C_L = 100\text{ pF}$  |
| Output-side start-up time                 | $t_{START,VCC2}$ |        | 5    | 10   | $\mu\text{s}$     | <sup>3)</sup> INA/B = High, DIS = Low / EN = High, DT = VCC1, $V_{VCC1} > V_{UVLOH1}$ , $C_L = 100\text{ pF}$     |
| Output-side deactivation time             | $t_{STOP,VCC2}$  | 0.5    |      | 1    | $\mu\text{s}$     | <sup>3)</sup> INA/B = High, DIS = Low / EN = High, DT = VCC1, $V_{VCC1} > V_{UVLOH1}$ , $C_L = 100\text{ pF}$     |
| High-level common-mode transient immunity | $ CM_H $         | 200    |      |      | kV/ $\mu\text{s}$ | <sup>3)</sup> $V_{CM} = 1500\text{ V}$ , INA/B tied to VCC1, DT = VCC1  |
| Low-level common-mode transient immunity  | $ CM_L $         | 200    |      |      | kV/ $\mu\text{s}$ | <sup>3)</sup> $V_{CM} = 1500\text{ V}$ , INA/B tied to GND1, DT = VCC1  |
| Dynamic common-mode transient immunity    | $ CM_{DYN} $     | 200    |      |      | kV/ $\mu\text{s}$ | <sup>3)</sup> $V_{CM} = 1500\text{ V}$ , INA/B = 10 MHz square wave, DT = VCC1                                    |

1) value at same ambient and operating conditions.

2) Valid for INA, INB and DIS/EN,  $V_{DT} = V_{VCC1}$ . The pulse is generated outside the DT window; shorter pulses will not propagate to the output.

3) Parameter is not subject to production test - verified by design/characterization

### 3.3.6 Active shut down

**Table 11** **Active shut down**

| Parameter                | Symbol      | Values |      |      | Unit | Note or condition  |
|--------------------------|-------------|--------|------|------|------|--|
|                          |             | Min.   | Typ. | Max. |      |  |
| Active shut down voltage | $V_{ACTSD}$ |        |      | 1.8  | V    | $V_{OUTA/B} - V_{VEE2A/B}$ , $I_{OUTL} = 500\text{ mA}$ , VCC2A/B open |

### 3.3.7 Overtemperature protection

**Table 12** Overtemperature protection

| Parameter                                | Symbol       | Values |      |      | Unit | Note or condition |
|--|--------------|--------|------|------|------|-------------------|
|  |              | Min.   | Typ. | Max. |      |                   |
| Overtemperature protection level         | $T_{OTPOFF}$ | 150    | 160  | 175  | °C   | 1)                |
| Overtemperature protection release level | $T_{OTPREL}$ | 130    | 140  | 150  | °C   | 1)                |
| Overtemperature protection hysteresis    | $T_{OTPHYS}$ |        | 20   |      | °C   | 1)                |

1) Parameter is not subject to production test - verified by design/characterization

## 4 Insulation characteristics (IEC 60747-17, UL 1577) for DSO-14 package

This coupler is suitable for rated insulation only within the given safety ratings. Compliance with the safety ratings shall be ensured by means of suitable protective circuits.

**Table 13** Insulation specification for DSO-14 package

| Description   | Symbol                | Characteristic                | Unit     |
|---|-----------------------|-------------------------------|----------|
| <b>Safety limiting values</b>   |                       |                               |          |
| Maximum ambient safety temperature  | $T_S$                 | 150                           | °C       |
| Maximum input-side power dissipation at $T_A = 25^\circ\text{C}^{1)}$   | $P_{SI}$              | 66                            | mW       |
| Maximum output-side power dissipation at $T_A = 25^\circ\text{C}^{2)}$  | $P_{SO}$              | 1600                          | mW       |
| <b>General</b>  |                       |                               |          |
| External clearance  | $CLR$                 | > 8                           | mm       |
| Channel-to-channel clearance  | $CLR_{\text{Ch-Ch}}$  | > 3.3                         | mm       |
| External creepage   | $CPG$                 | > 8                           | mm       |
| Channel-to-channel creepage   | $CPG_{\text{Ch-Ch}}$  | > 3.3                         | mm       |
| Comparative tracking index  | $CTI$                 | > 400                         | –        |
| Isolation capacitance   | $C_{IO}$              | 2                             | pF       |
| Overvoltage category according to IEC 60664-1, Table F.1<br>for rated mains voltage $\leq 150$ V (rms)<br>for rated mains voltage $\leq 300$ V (rms)<br>for rated mains voltage $\leq 600$ V (rms)<br>for rated mains voltage $\leq 1000$ V (rms) |                       | I-IV<br>I-IV<br>I-IV<br>I-III | –        |
| <b>Reinforced insulation according to IEC 60747-17 (Certificate no. 40055138)</b>   |                       |                               |          |
| Climatic classification   |                       | 40/125/21                     | –        |
| Pollution degree (IEC 60664-1)  |                       | 2                             | –        |
| Apparent charge, method a<br>$V_{pd(\text{ini}),a} = V_{IOTM}$ , $V_{pd(m)} = 1.6 \times V_{IORM}$ , $t_{\text{ini}} = 1$ min, $t_m = 10$ s   | $q_{pd}$              | < 5                           | pC       |
| Apparent charge, method b<br>$V_{pd(\text{ini}),b} = V_{IOTM} \times 1.2$ , $V_{pd(m)} = 1.875 \times V_{IORM}$ , $t_{\text{ini}} = 1$ s, $t_m = 1$ s   | $q_{pd}$              | < 5                           | pC       |
| Isolation resistance at $T_{A,\text{max}}$ ; $V_{IO} = 500$ V <sub>DC</sub> , $T_A = 125^\circ\text{C}$   | $R_{IO}$              | > $10^{11}$                   | $\Omega$ |
| Isolation resistance at $T_S$ ; $V_{IO} = 500$ V <sub>DC</sub> , $T_S = 150^\circ\text{C}$  | $R_{IO\_S}$           | > $10^9$                      | $\Omega$ |
| Maximum rated transient isolation voltage   | $V_{IOTM}$            | 8000                          | V (peak) |
| Maximum repetitive isolation voltage  | $V_{IORM}$            | 1767                          | V (peak) |
| Maximum working isolation voltage   | $V_{IOWM}$            | 1249                          | V (rms)  |
|   |                       | 1767                          | V (DC)   |
| Impulse voltage   | $V_{IMP}$             | 8000                          | V (peak) |
| Maximum surge isolation voltage for reinforced isolation; $V_{\text{TEST}} \geq V_{IMP} \times 1.3$   | $V_{IOSM}$            | 11000                         | V (peak) |
| <b>Recognized under UL 1577 (File 311313)</b>   |                       |                               |          |
| Insulation withstand voltage (60 s)   | $V_{ISO}$             | 5700                          | V (rms)  |
| Insulation test voltage (1 s)   | $V_{ISO,\text{TEST}}$ | 6840                          | V (rms)  |

1) IC input-side power dissipation is derated linearly at 14 mW/°C above 145 °C

5 Typical characteristics

2) IC output-side power dissipation is derated linearly at 12.6 mW/°C above 25 °C

5 Typical characteristics

Unless otherwise stated, the measurements are done with  $V_{VCC1} = 3.3\text{ V}$ , 100 nF capacitor connected between  $VCC1$  and  $GND1$ , 4.7  $\mu\text{F}$  capacitor between  $VCC2A/B$  and  $VEE2A/B$ .

Table 14

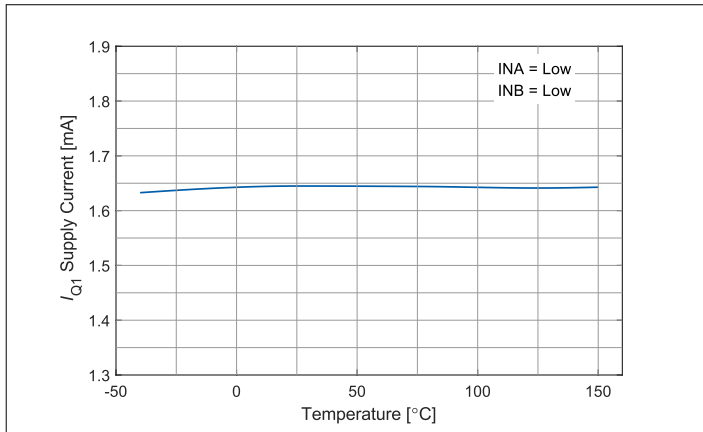

Figure 5  $I_{Q1}$  vs. temperature

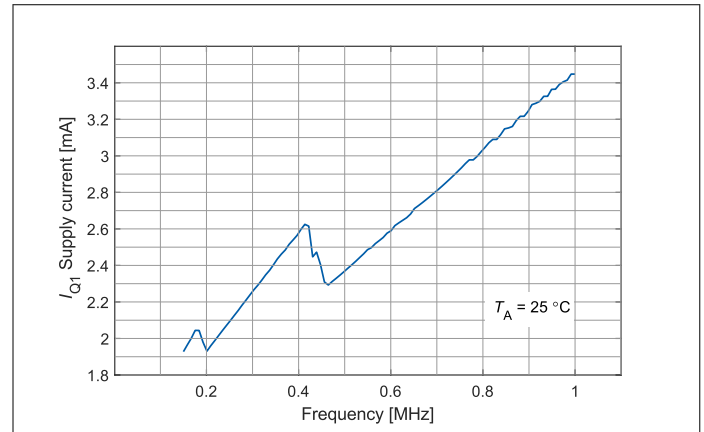

Figure 6  $I_{Q1}$  vs. frequency

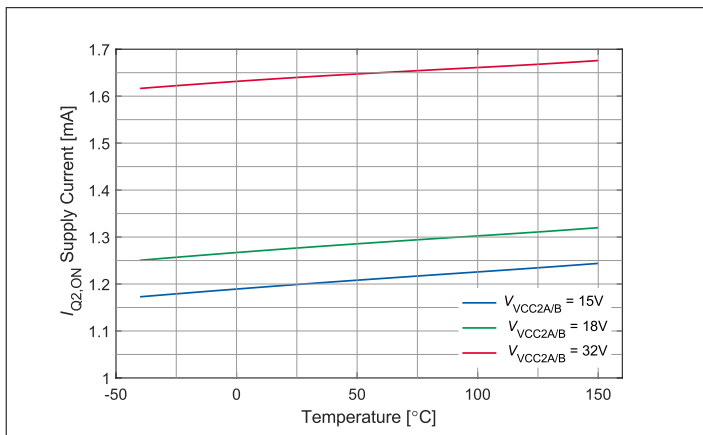

Figure 7  $I_{Q2,ON}$  vs. temperature

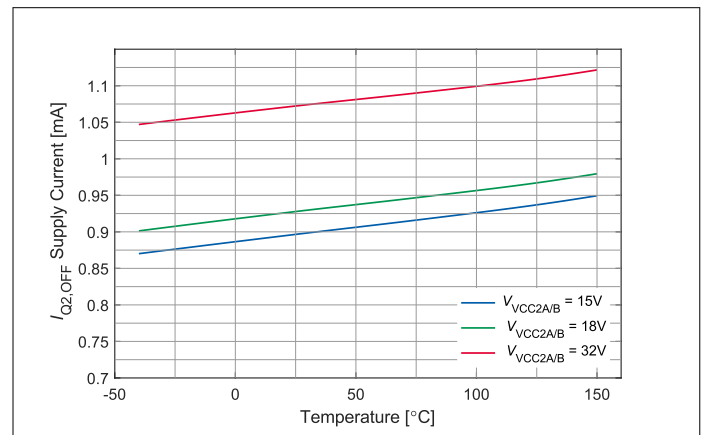

Figure 8  $I_{Q2,OFF}$  vs. temperature

(table continues...)

5 Typical characteristics

Table 14 (continued)

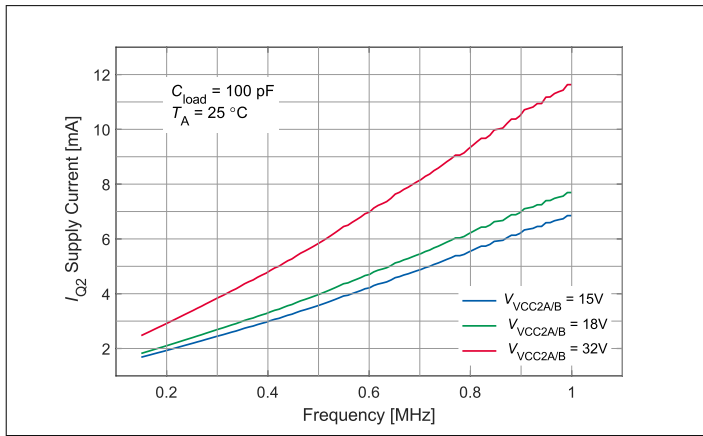

Figure 9  $I_{Q2}$  vs. frequency

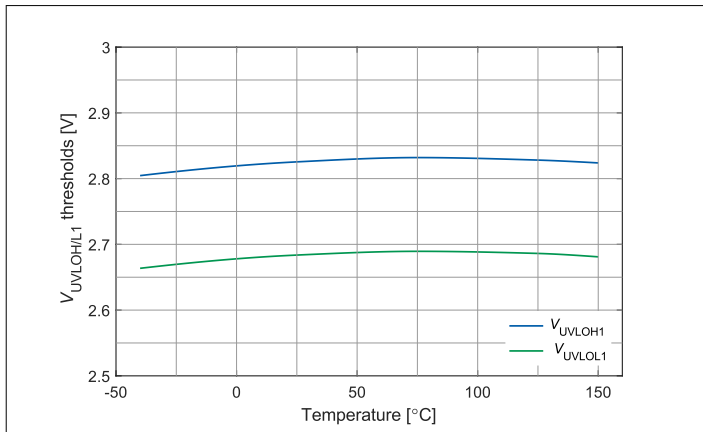

Figure 10  $V_{UVLOH1}$  and  $V_{UVL0L1}$  vs. temperature

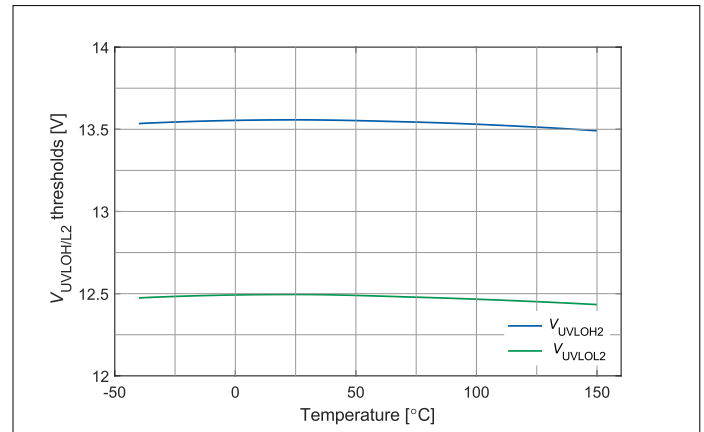

Figure 11  $V_{UVLOH2}$  and  $V_{UVL0L2}$  (2ED3146MC12L) vs. temperature

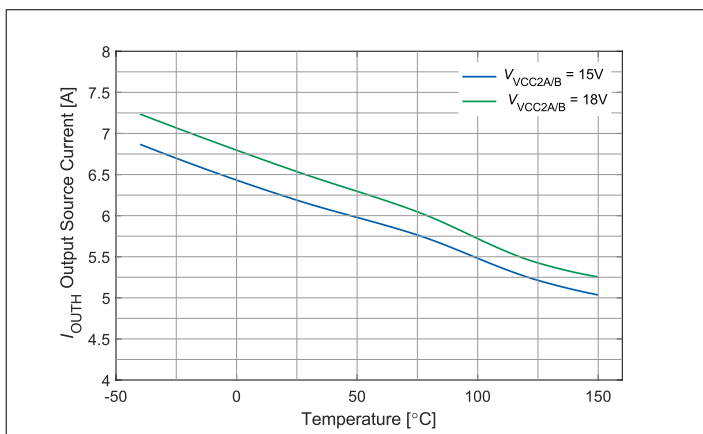

Figure 12  $I_{OUTH}$  vs. temperature

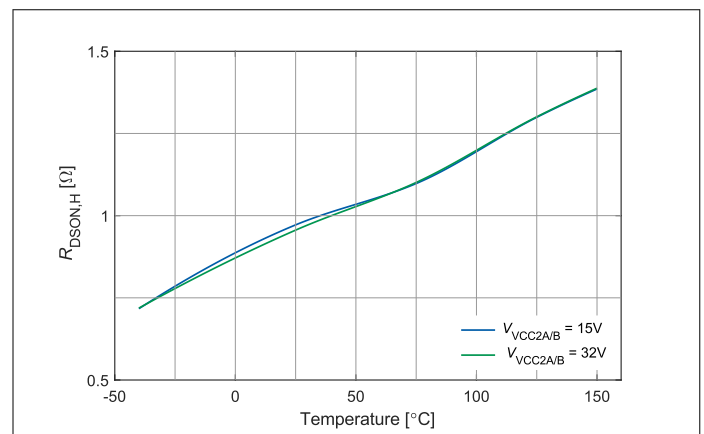

Figure 13  $R_{DS(on),H}$  vs. temperature

(table continues...)

5 Typical characteristics

Table 14 (continued)

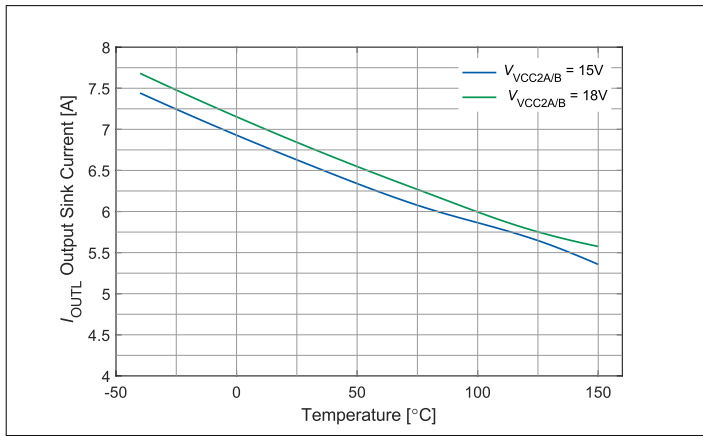

Figure 14  $I_{OUTL}$  vs. temperature

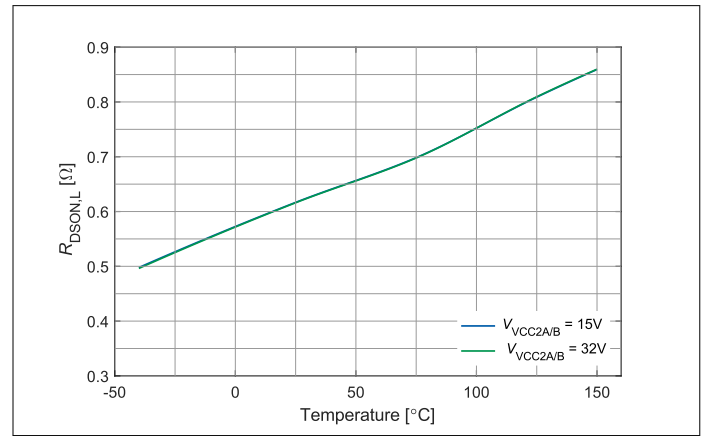

Figure 15  $R_{DS(on),L}$  vs. temperature (lines are overlapping)

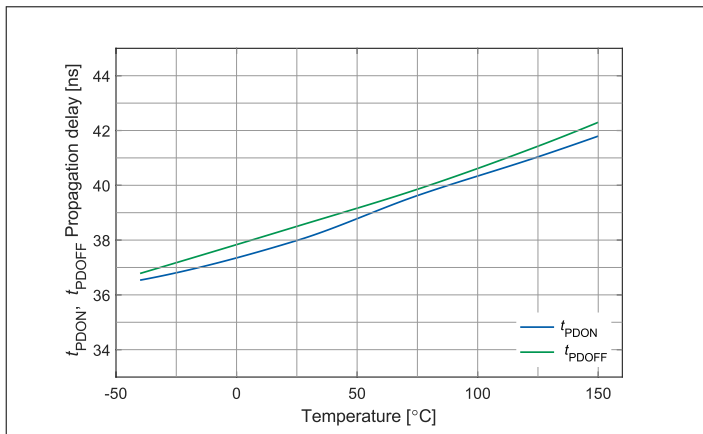

Figure 16  $t_{PD(on)}$  &  $t_{PD(off)}$  vs. temperature

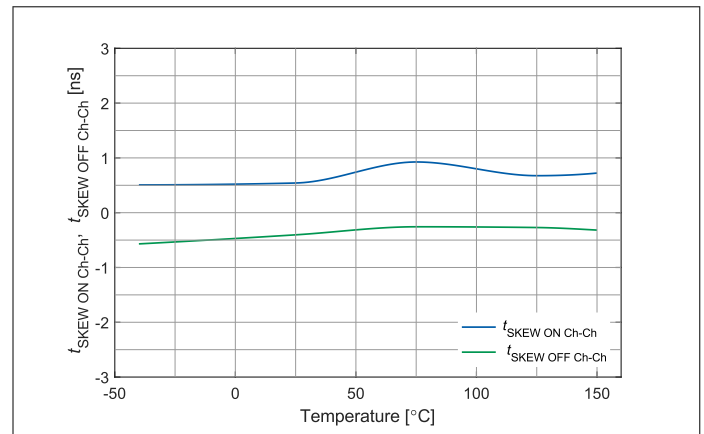

Figure 17  $t_{SKEW\_ON,Ch-Ch}$  &  $t_{SKEW\_OFF,Ch-Ch}$  vs. temperature

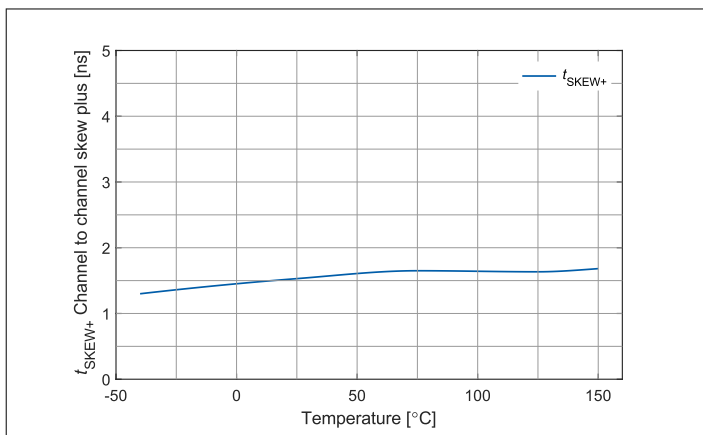

Figure 18  $t_{SKEW+}$  vs. temperature

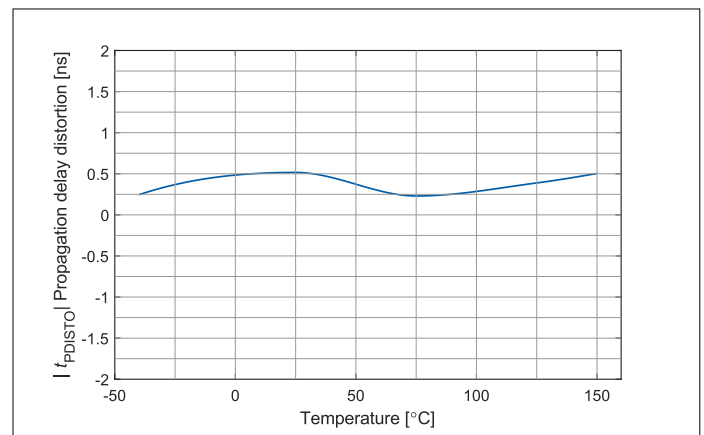

Figure 19  $|t_{PDISTO}|$  vs. temperature

(table continues...)

5 Typical characteristics

Table 14 (continued)

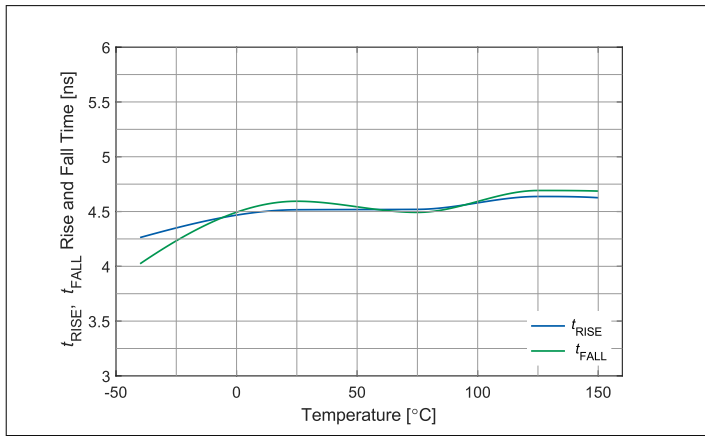

Figure 20  $t_{\text{RISE}}$  &  $t_{\text{fall}}$  vs. temperature

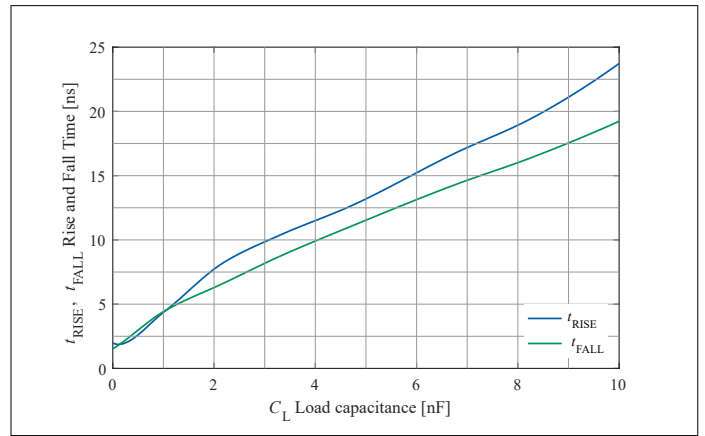

Figure 21  $t_{\text{RISE}}$  &  $t_{\text{fall}}$  vs.  $C_{\text{LOAD}}$

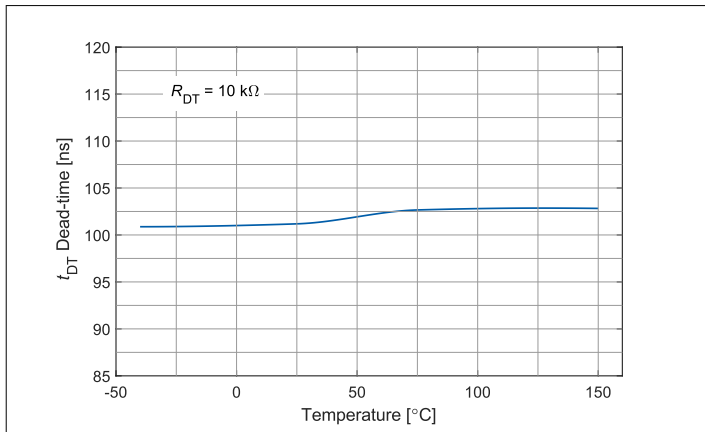

Figure 22  $t_{\text{DT}}$  vs. temperature

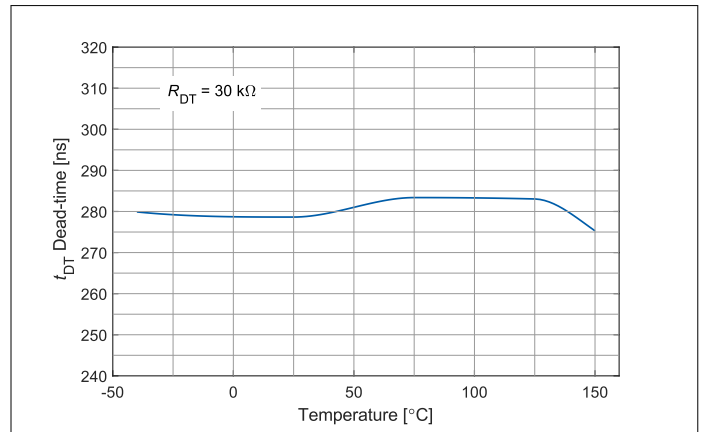

Figure 23  $t_{\text{DT}}$  vs. temperature

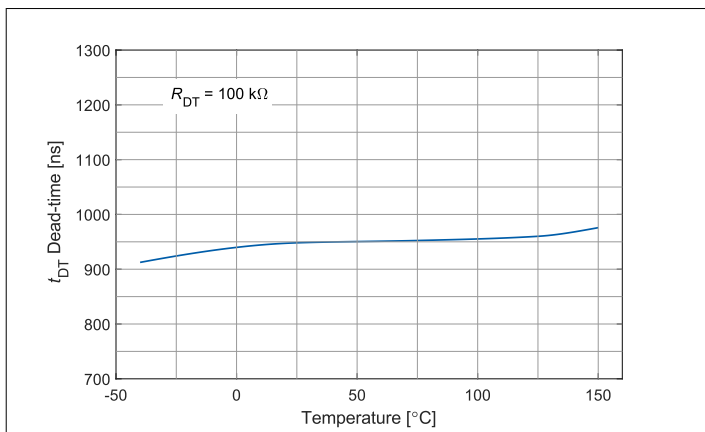

Figure 24  $t_{\text{DT}}$  vs. temperature

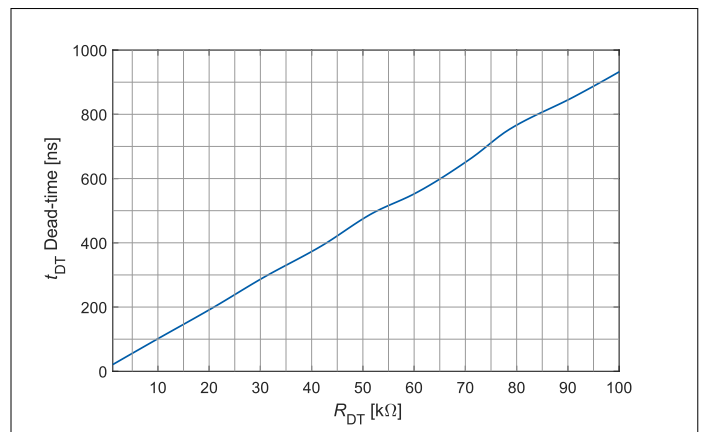
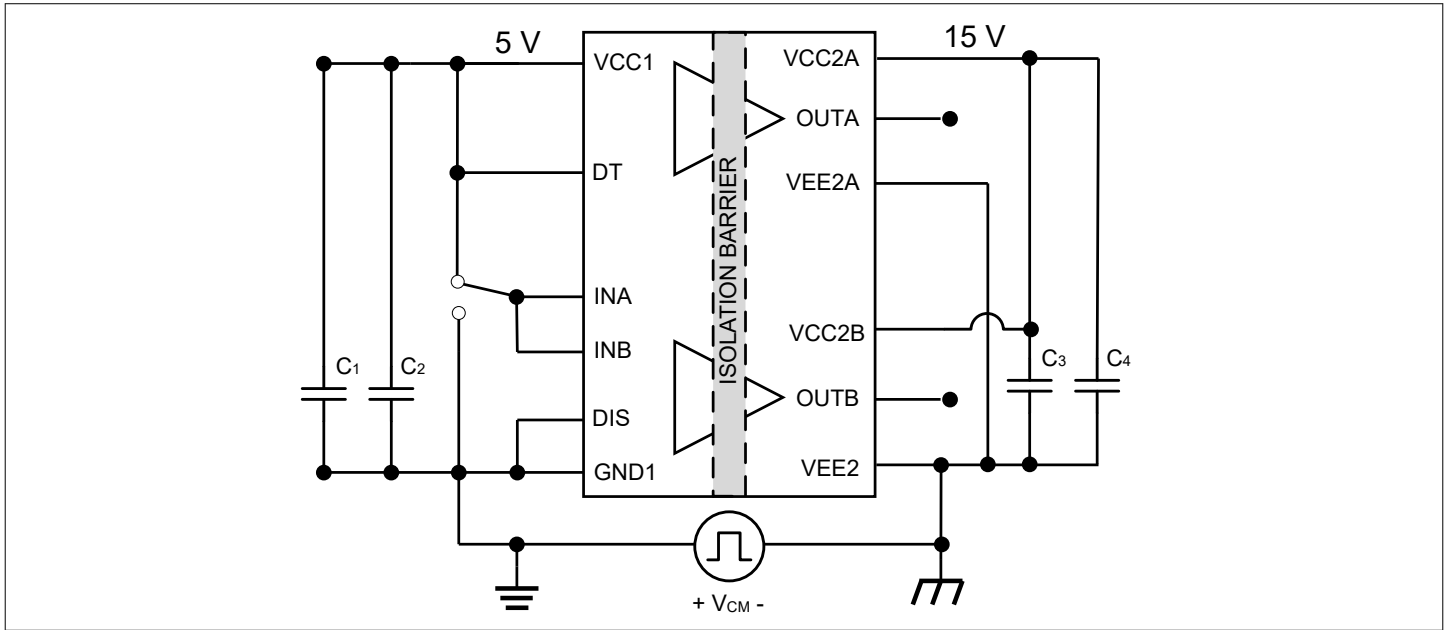

Figure 25  $t_{\text{DT}}$  vs.  $R_{\text{DT}}$

## 6 Parameter measurement

### 6.1 CMTI measurement setup



**Figure 26** Static CMTI test circuit

Figure 26 above shows the test setup for static, common-mode transient immunity

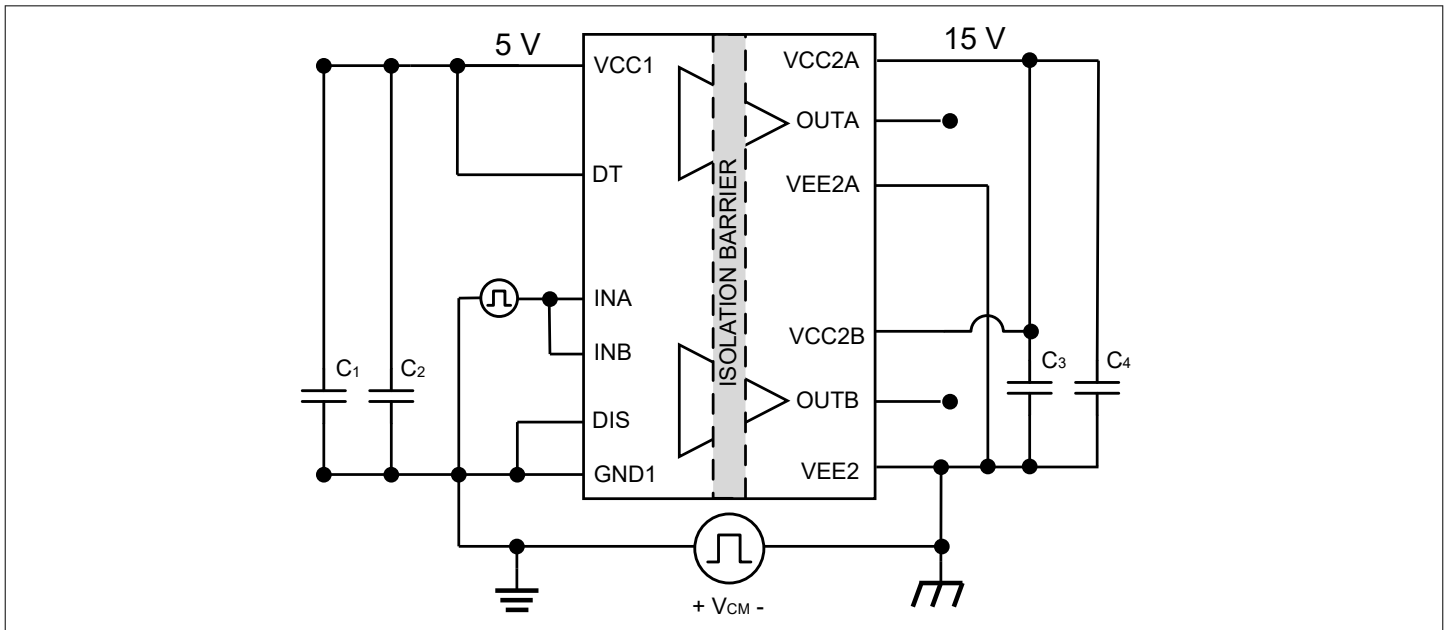

**Figure 27** Dynamic CMTI test circuit

Figure 27 shows the test setup for dynamic, common-mode transient immunity

### 6.2 Undervoltage lockout (UVLO)

Figure 28 shows the behavior of the channel outputs under UVLO conditions. To measure the thresholds, *INA* and *INB* are held at logic high and then the power supply voltages  $V_{CC1}$  and  $V_{CC2x}$  are ramped down and up. When the

6 Parameter measurement

voltages decrease below the  $V_{UVLOLx}$  levels, the channels turn off, allowing the threshold to be measured. When the voltages rise above  $V_{UVLOHx}$ , the channels turn on, enabling the measurement of the thresholds again. All the thresholds are measured using slow ramps on all supplies.

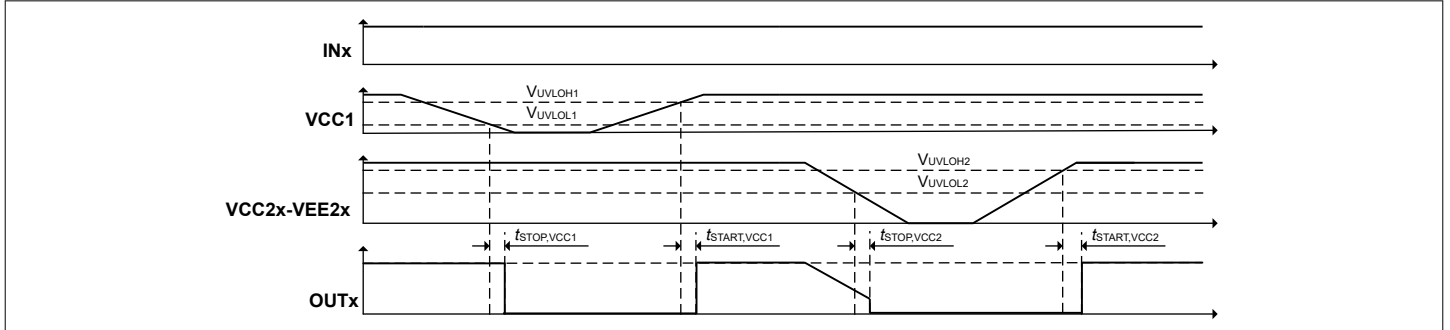

Figure 28 UVLO behavior

6.3 Propagation delay, rise and fall time

Figure 29 and Figure 30 show the propagation delays  $t_{PDON}$  and  $t_{PD OFF}$  for  $INA$  and  $INB$ , as well as  $DIS$ , including the rise time,  $t_{RISE}$ , and fall time,  $t_{FALL}$ .

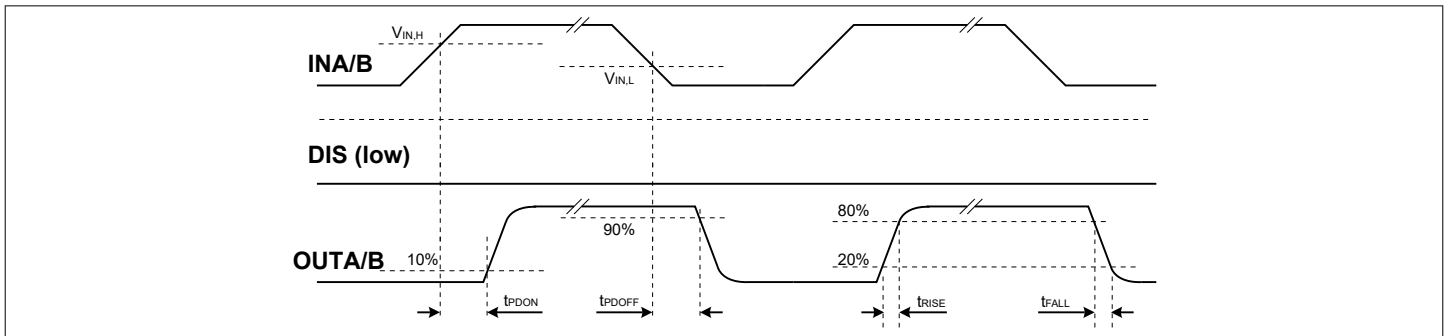

Figure 29 Propagation delay for DIS variants

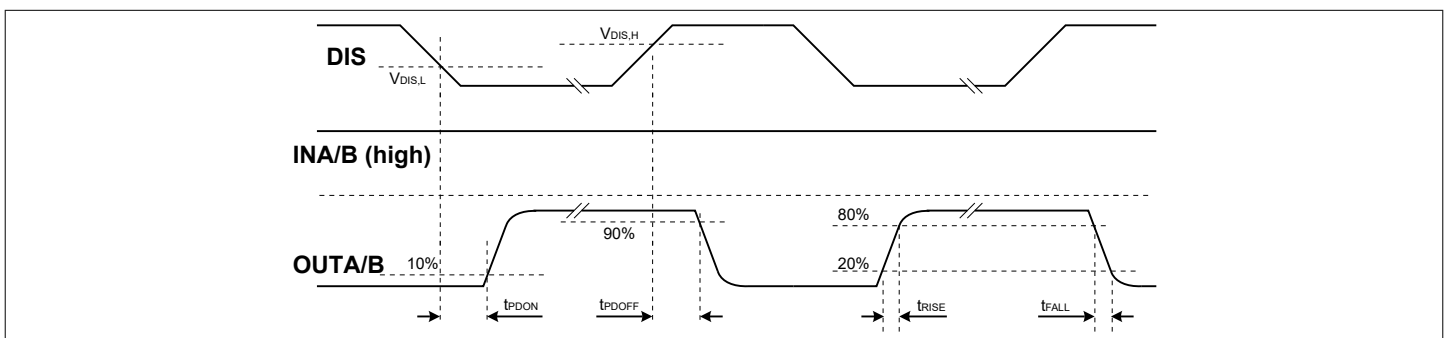

Figure 30 Propagation delay for the DIS pin

Figure 31 and Figure 32 show the propagation delays  $t_{PDON}$  and  $t_{PD OFF}$  for  $INA$  and  $INB$ , as well as  $EN$ , including the rise time,  $t_{RISE}$ , and fall time,  $t_{FALL}$ .

6 Parameter measurement

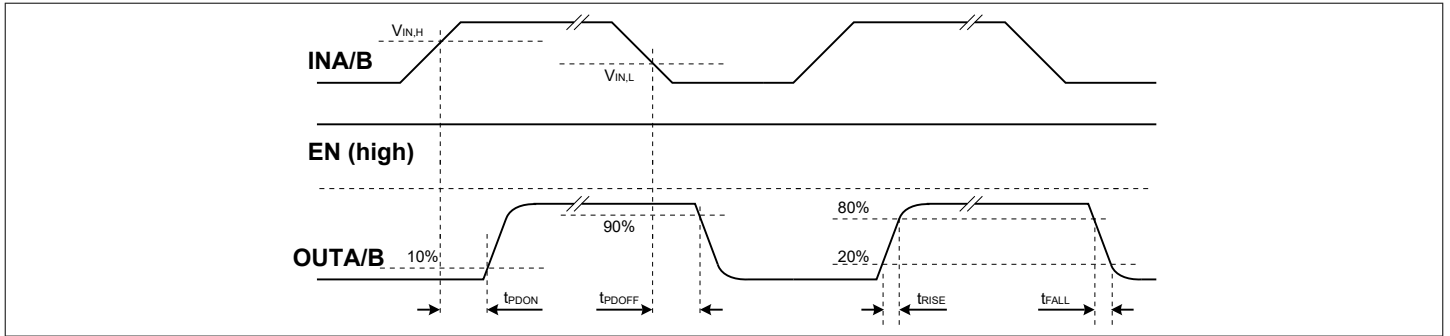

Figure 31 Propagation delay for EN variants

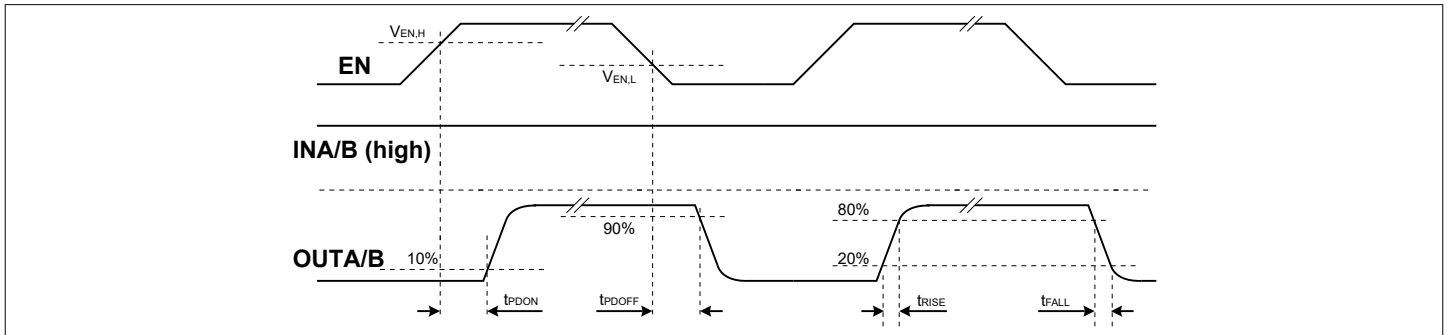

Figure 32 Propagation delay for the EN pin

6.4 Deadtime matching, skew, and skew+

The channel-to-channel dead-time matching  $\Delta t_{DT,Ch-Ch}$  is defined as the absolute difference between the dead-times generated by the falling edges of the two channels, *INA* and *INB*.

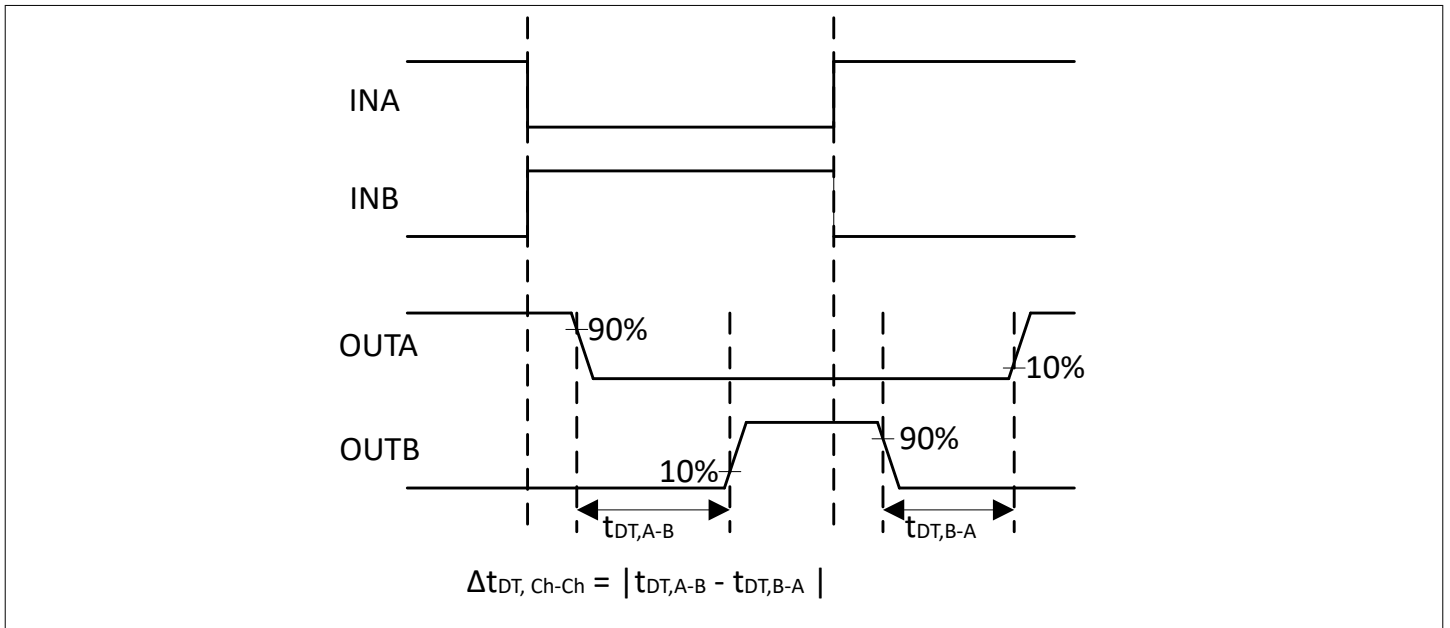
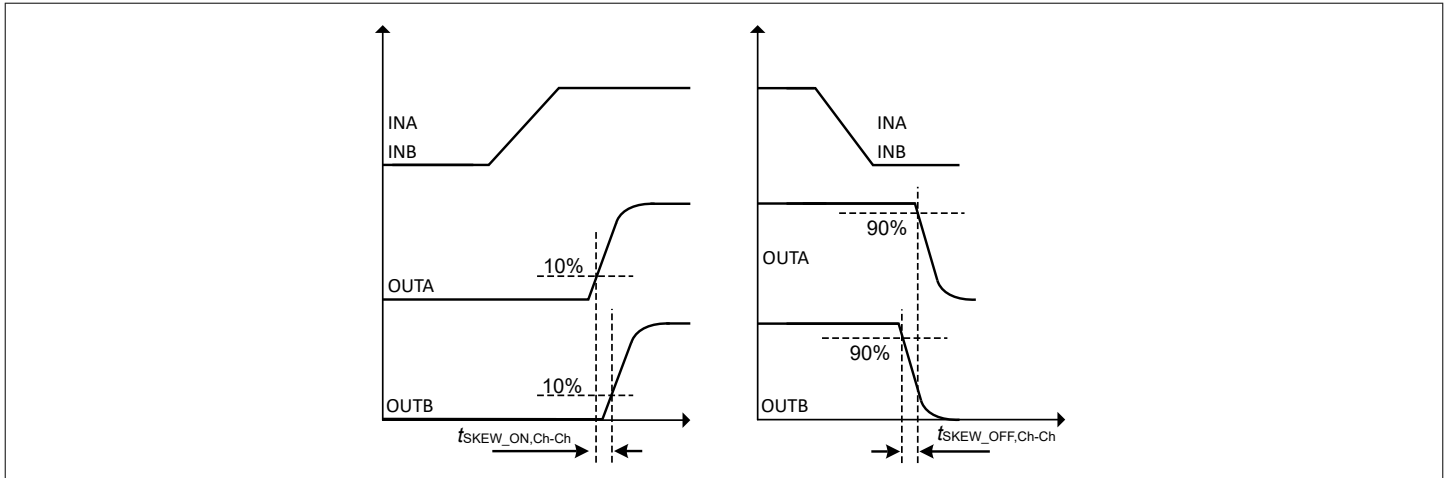

Figure 33 Channel-to-channel deadtime matching

Figure 34 illustrates the channel-to-channel turn-on skew,  $t_{SKEW\_ON,Ch-Ch}$  and the channel-to-channel turn-off skew,  $t_{SKEW\_OFF,Ch-Ch}$ . These parameters highlight the mismatch in propagation delay between the two channels when simultaneous pulses with the same edge are applied to the two channels, and are relevant when paralleling gate drivers.



**Figure 34** Input-to-output, channel-to-channel skew for rising and falling edges

Figure 35 illustrates the channel-to-channel skew+,  $t_{SKEW+,Ch-Ch}$ . This parameter describes the variation between the turn-on and turn-off propagation delays of separate channels in a half-bridge. This is relevant during complimentary driving of the channels drivers and helps define the minimum dead-time required for safe operation.

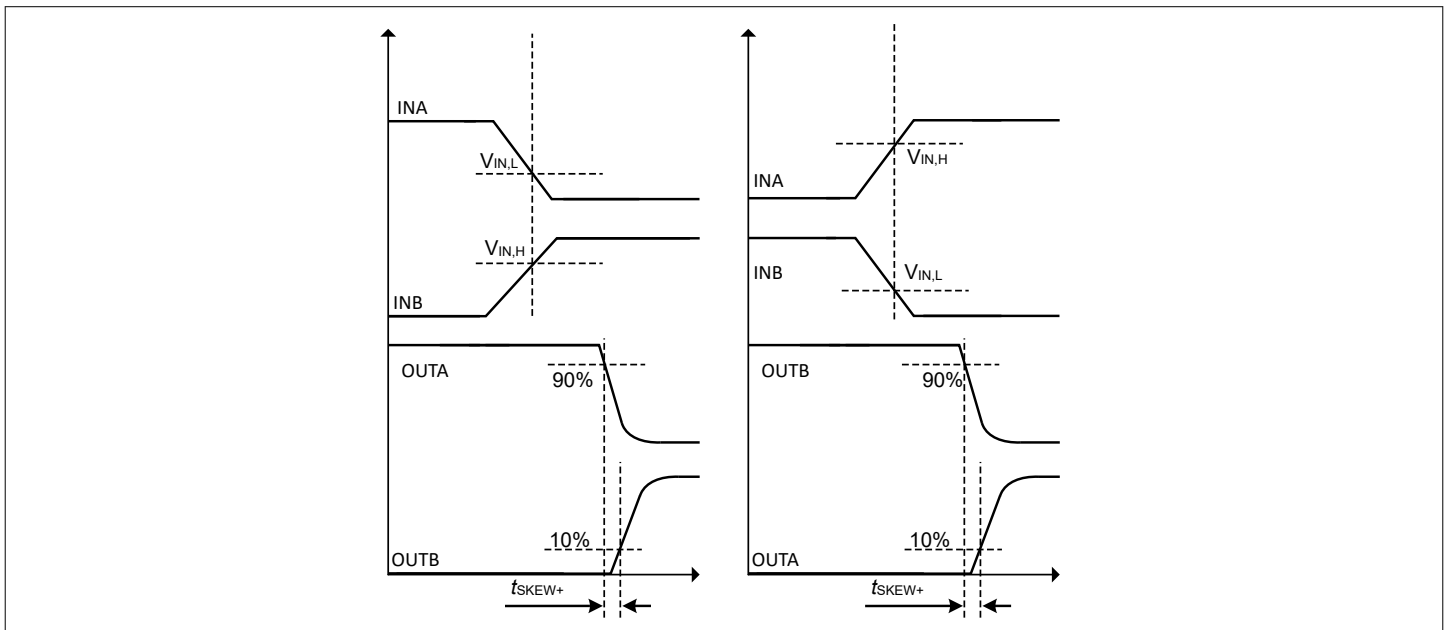

**Figure 35** Input-to-output, channel-to-channel skew+ for rising and falling edges

All skew parameters are valid when the channels and gate drivers are operated under the same bias and temperature conditions.

## 7 Functional description

### 7.1 Input-side functional blocks

The input side of the gate driver contains several blocks, that ensure the interfacing to the microcontroller, and the data transmission across the isolation barrier.

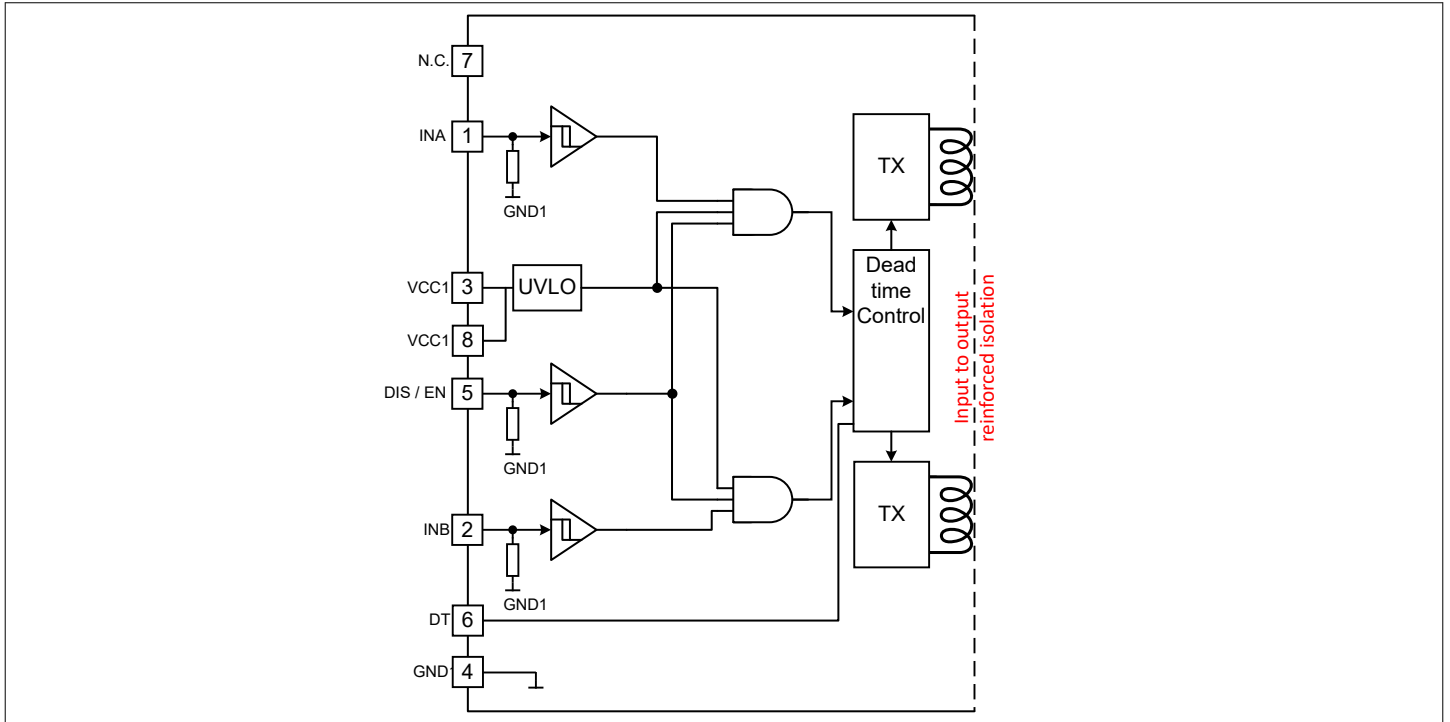

**Figure 36** Input-side block diagram

The following blocks are available:

- Input supply undervoltage lockout
- Input signal filters
- Pull-down resistors
- Dead-time control

#### 7.1.1 Input supply undervoltage lockout (UVLO)

The UVLO block on the input chip monitors the voltage between the *VCC1* and the *GND1* pins and ensures that there is enough voltage between these pins for the internal circuitry to operate correctly.

As long as the voltage between these two pins is below  $V_{UVLOL1}$ , no turn-on signals coming on the *INA* or *INB* pins are sent across the isolation barrier, and the channels are by default turned off.

To allow turn-on signals to cross the isolation barrier, the voltage between the *VCC1* and the *GND1* pins must exceed the  $V_{UVLOH1}$  threshold and stay above  $V_{UVLOL1}$ . Otherwise the communication across the isolation barrier is disabled and the channels are turned off.

Although the UVLO ensures that the voltage between the *VCC1* and *GND1* pins is large enough, it does not provide protection against dynamic disturbances coming across the supply lines, that can propagate to the internal circuits of the device.

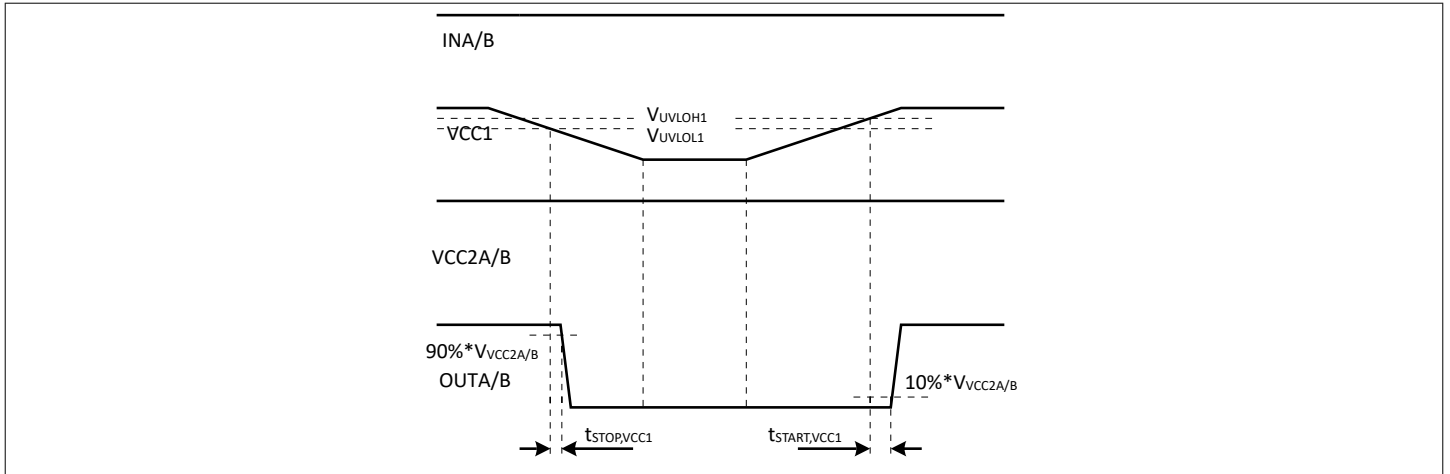

Figure 37 Input-side UVLO behavior

### 7.1.2 Input signal filters

Every pulse at *INA*, *INB*, or *DIS/EN*, that is shorter than the input pulse suppression time,  $t_{INFLT}$ , will be filtered and is not be transmitted to the output chip. Longer pulses are sent to the output with the propagation delay  $t_{PDON}$  and  $t_{PDOFF}$  shown in Figure 38. This aids the design and an external RC filter for noise suppression is not be needed in most cases.

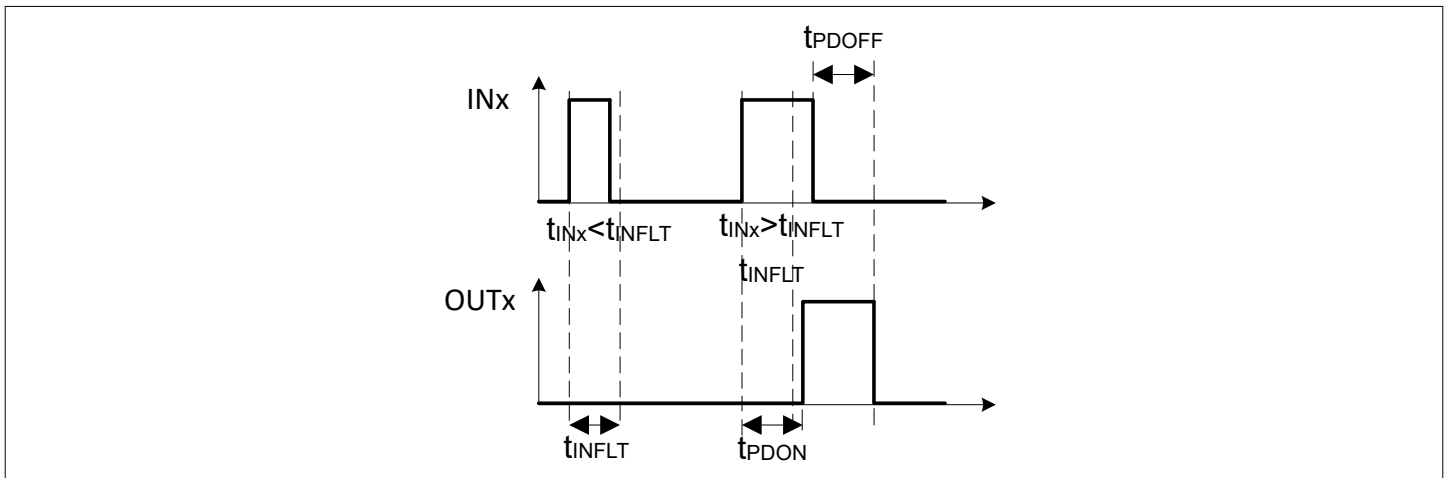

Figure 38 Input filter behavior

### 7.1.3 Pull-down resistors

Each of the digital input pins has a pull-down resistor attached to it. This ensures that in case the pin is desoldered from the board, it is pulled to a safe state with the channels disabled. This is valid for *INA*, *INB* and the variants with *EN* pins. The variants with *DIS* pins allow a simpler driving, as well as lower current consumption because the driver is active, by default. But it is highly recommended not to leave this pin floating, and if not actively driven by the microcontroller, it should be connected to *GND1*.

### 7.1.4 Dead-time control

The Dead-time control block implements the non-overlapping between the two channels, depending on the state of the *DT* pin. The following states and behaviors are defined:

- *DT* connected to *GND1*: A minimal (<10 ns) shoot-through protection between the channels is implemented

7 Functional description

- *DT* connected to *VCC1* or left floating: The two channels behave as independent drivers
- *DT* is connected through a resistor to *GND1*: A dead-time is implemented between the falling edge of a channel and the rising edge of the other channel, as per the following equation:

$$t_{DT} = K_{DT\_R} \times R_{DT} + M_{DT\_R} \quad (1)$$

Note that in case the *DT* pin disconnects during operation the device will not automatically transition to independent driver mode.

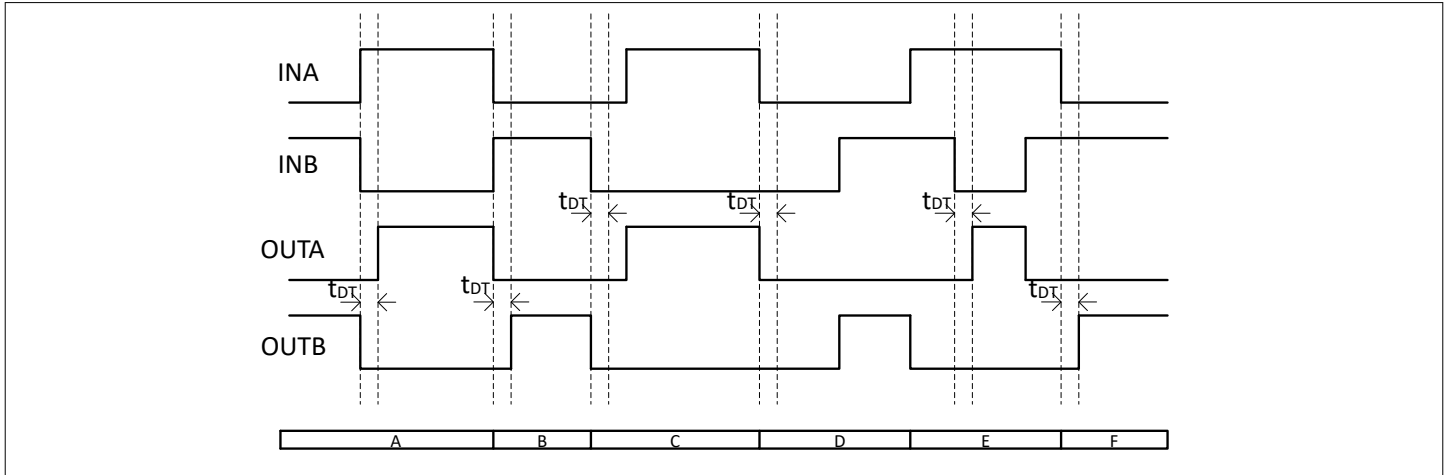

**Figure 39** Dead-time special pulses

When a resistor is connected to the *DT* pin, the following behaviors are defined:

- A and B: When complementary signals appear at the input pins at the same time, the dead-time will be generated at the falling edge of the turned off channel. Only after it has expired, the turn-on of the other channel is triggered
- C: If the turn-on signal on one channel has appeared after a time greater than  $t_{DT}$  from the turn-off of the other channel, the dead-time is not visible at the output of the two channels
- D: If a channel receives a turn-on command when the other channel is already on, both channels are turned immediately off until the condition at the input disappears
- E and F: When exiting condition D, a dead-time is generated from the turn-off command of one channel, until the other channel is turned on

Connecting capacitors to the *DT* pin is not recommended..

## 7.2 Output-side functional blocks

The output side of the device contains two identical ICs, each driving one of the output channels. Each IC has the following blocks:

- Output-side undervoltage lockout (UVLO)
- Short-circuit clamping
- Active shutdown
- Overtemperature protection (OTP)

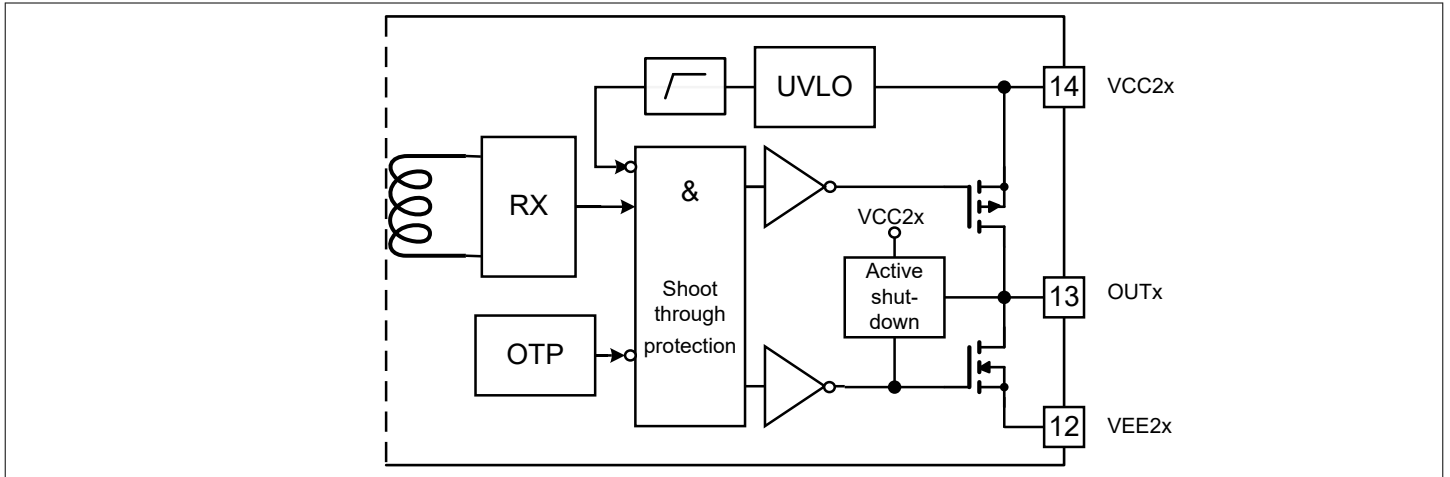

Figure 40 Output-side block diagram

### 7.2.1 Output-side undervoltage lockout (UVLO)

The UVLO block on the output chip monitors the voltage between the  $VCC2A/B$  and the  $VEE2A/B$  pins and ensures that there is sufficient voltage between these pins to drive the connected switch properly.

As long as the voltage between these two pins is below  $V_{UVLOL2}$ , no turn on signals coming across the isolation barrier will change the output state, and the channels are by default turned off.

To allow the channels to turn on, the voltage between the  $VCC2A/B$  and the  $VEE2A/B$  pins must exceed the  $V_{UVLOH2}$  threshold and stay above  $V_{UVLOL2}$ . Otherwise the channels will turn off automatically, regardless of the state of the input pins.

The charge required to turn-on the power switch connected to the channel is provided by the buffer capacitor connected between the  $VCC2A/B$  and  $VEE2A/B$ . Therefore, this capacitor must be dimensioned such that during or after the turn-on event, the voltage between these two pins does not drop below  $V_{UVLOL2}$ , as this will automatically trigger the turn-off of the driver.

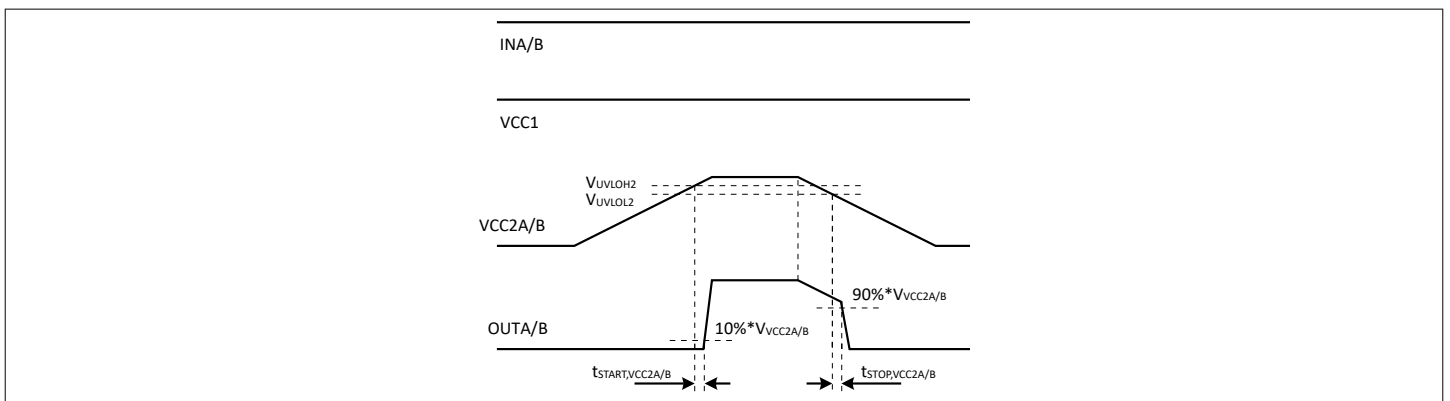

Figure 41 Output-side UVLO behavior

### 7.2.2 Short-circuit clamping

During short-circuit, the gate voltage of the power transistor tends to rise because of the feedback from the Miller capacitance. In such a situation, the IC clamps the voltage on the *OUTA/B* pins internally and limits the voltage to a value slightly higher than the supply voltage,  $V_{VCC2A/B}$ . A maximum current of 500 mA may be fed back to the supply through this path for 10  $\mu$ s. If higher currents are expected or tighter clamping is desired, external Schottky diodes should be added between the *OUTA/B* and *VCC2A/B* pins.

### 7.2.3 Active shutdown

The active shutdown function is a protection feature of the driver. It is designed to prevent the power switch from turning on because of a floating gate.

The active shutdown feature ensures a safe OFF state for IGBTs, Si, or SiC MOSFETs in case the output chip is not connected to a power supply or an undervoltage lockout is in effect. The IGBT, Si, or SiC MOSFET gate is clamped via the *OUTA/B*-pin to *VEE2A/B*.

In case of a missing or collapsing power supply at the *VCC2A/B* pin, the output section of the driver operates in the active shutdown mode. In this case, the driver uses the floating voltage of the connected gate to supply this internal circuit. This solution is far stronger than the one using an external resistor placed between the gate and the source pins of the power switch. At the same time, if  $dV/dt$  events on the switch generate a Miller current that could bias the gate, even when the gate driver is not powered on, the active shutdown circuit uses the voltage to power itself and actively pulls the gate low. The active shutdown feature functions in a similar manner across all IC variants.

### 7.2.4 Overtemperature protection

The overtemperature protection feature shuts down the output of the gate driver IC and protects the application when the junction temperature of the IC exceeds the threshold temperature,  $T_{OTPOFF}$ . The output is then kept off until the temperature reaches the safe level,  $T_{OTPREL}$ . After the safe level is reached, the output is turned on again if a turn-on command is sent.

Though the overtemperature protection feature attempts to protect the device, note that operating the driver above  $T_J$  can potentially damage the driver permanently.

## 8 Application information

Note: Infineon is providing this information as a courtesy only and without acknowledging any legal obligation. Information in the following application chapters is not part of the Infineon component specification, and Infineon does not warrant its accuracy or completeness. Infineon's customers are responsible for determining the suitability of the components for their purposes. Customers should validate and test their design implementation to confirm system functionality.

### 8.1 Typical application

This section describes how the gate drivers can be used in the application.

Figure 42 and Figure 43 show examples of application implementations.

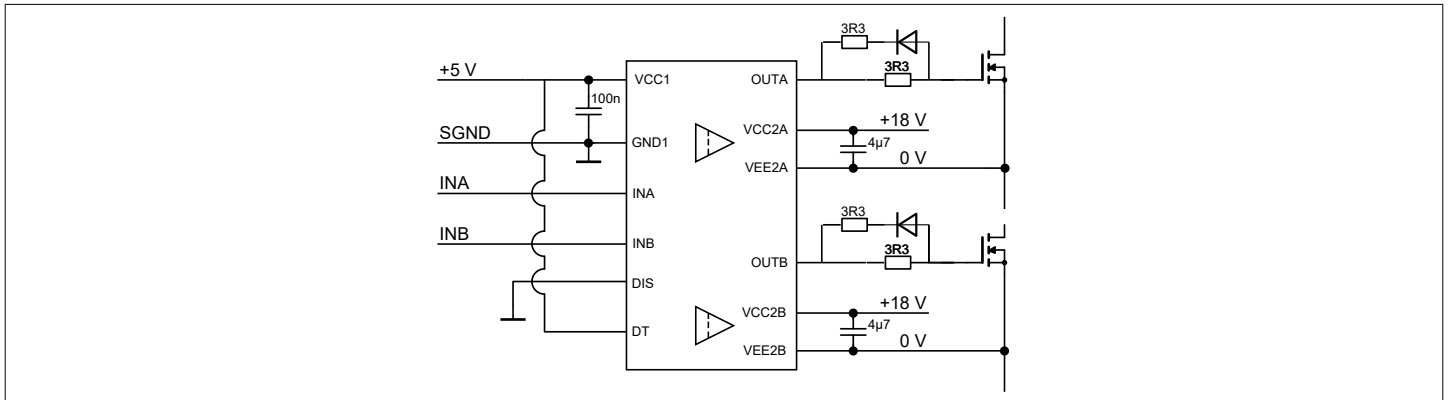

**Figure 42** Independent dual channel operation with unipolar biasing using SiC switches

To operate the driver as two independent channels, the *DT* pin should be connected to the input supply pin *VCC1*. This way, the driver does not impose any dead-time between the *INA* and *INB* signals. This operating mode can be used when dealing with space restrictions or in very cost-sensitive applications. Also shown in Figure 42 is the usage of unipolar power supplies. Here *VEE2A/B* pin should be connected directly to the source or emitter of the power transistor. This biasing strategy can be used when using switches without parasitic turn-on, or at a lower *dV/dt* of the switching node. To obtain different turn-on and turn-off speeds, a diode and an additional series resistor can be added in parallel to the already existing gate resistor. In Figure 42, the equivalent discharging resistor is roughly half of the charging resistor. In such scenarios, Schottky diode should be used and its voltage drop must be considered.

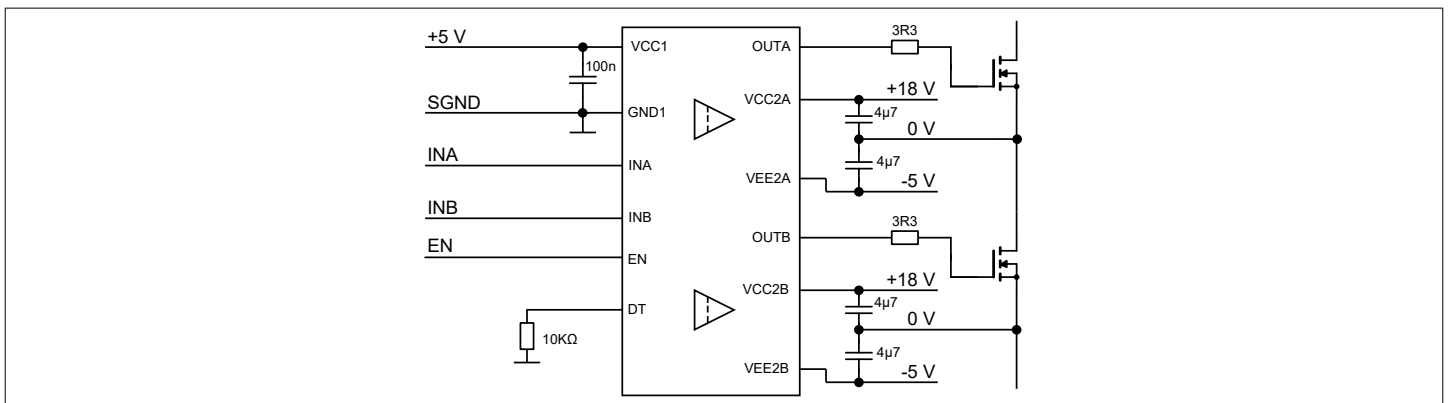

**Figure 43** Half-bridge operation with bipolar biasing using SiC switches

The device can also be operated in half-bridge mode, by connecting a resistor between the *DT* and the *GND1* pins. When this is done, the driver implements a dead-time between the falling edge of one channel and the rising edge of the other channel. Note that the dead-time distortion  $|t_{DTD}|$  must also be taken into account. Also shown in the picture is the usage of a bipolar driving supply. In this case, a virtual ground is realized using two capacitors connected in series from *VCC2A/B* to *VEE2A/B*, with the middle point connected to the source or emitter of the driven switch.

## 8.2 Power supply recommendations

The 2ED314xMC12L gate drivers support a wide range of voltages on the input and the output side. The devices can operate with unipolar as well as bipolar power supply voltages on the output side for reliable and safe operation in the application.

To ensure that the gate driver operates correctly, it is necessary to place appropriate decoupling capacitors on the power supply pins. On the input side, it is recommended to place a low ESR, surface-mounted, multilayer ceramic capacitor of 100 nF between the *VCC1* and *GND1*. This capacitor should be placed as close as possible to the pins. The decoupling capacitors on the output side, in addition to decoupling any disturbance on the power supply, also store the energy necessary to deliver the peak currents required for turning the power transistor on and off. Therefore, these capacitors should be dimensioned appropriately to limit the voltage drop during the power transistor turn-on and off. When using a unipolar power supply, a low ESR, surface-mounted, multilayer ceramic capacitor of at least 4.7 µF should be placed between the *VCC2A/B* pin and the *VEE2A/B* pin in the close proximity to the pins. In case of a bipolar power supply, using ceramic capacitors of at least 4.7 µF capacitance between *VCC2A/B* and virtual ground (source or emitter potential of power transistor) and between *VEE2A/B* pin and virtual ground is recommended. Depending on the gate charge of the power transistor and the peak source and sink gate currents, a higher capacitance may be necessary to limit the voltage drop during power transistor turn-on and turn-off. Finally, a 100 nF decoupling capacitor is recommended between *VCC2A/B* and *VEE2A/B* pins ensuring a short path between them to decouple any high frequency noise.

When selecting the capacitors, it is important to consider the capacitance drop of ceramic capacitors with respect to the applied DC voltage.

## 8.3 Gate resistor selection

The gate resistor is a key component in the gate drive circuit. The gate resistor limits the source and the sink current of the gate driver, thereby controlling the switching speed of the associated power transistor during both turn-on and turn-off operations. Thus, carefully selecting an appropriate gate resistor is vital in the design process. Some important considerations for selecting the gate resistance are:

- Optimize the switching losses
- Limit the overshoots and oscillations of the drain-source voltage or the collector emitter voltage of the power transistor during turn-off
- Limit the overshoot and oscillations of the drain current or collector current during turn-on
- Dampen the oscillations of the gate-source or gate-emitter voltage caused by the parasitic inductances and capacitances in the gate loop

As a starting point the gate driver selection, the gate resistor used in the datasheet of the power transistor for the characterization of the turn-on and turn-off losses can be used. The power supply conditions are rarely the same as the supply conditions given in power transistor data sheets. Therefore, an adaptation of the power transistor datasheet values is required to obtain a starting point for the optimization of the final gate resistor. The method proposed here uses the same peak gate current value for both the actual application and the power transistor datasheet.

The peak gate current as per power transistor's datasheet equals to:

$$I_{G, pk} = \frac{\Delta V_{GS}}{R_{G, datasheet} + R_{G, int}} = \frac{\Delta V_{GS}}{R_{G, application} + R_{G, int}} \quad (2)$$

with  $\Delta V_{GS} = V_{VCC2} - V_{VEE2}$

Solving this equation for  $R_G$  leads to:

$$R_G = \frac{\Delta V_{GS}}{I_{G, pk}} - R_{G, int} \quad (3)$$

This method results in a starting point for selecting the gate resistor. Further evaluations, such as EMI measurements, are required for the final dimensioning of the gate resistors as they have to be adjusted to work with the circuitry inductance, margins, and allowed dV/dt transients.

While dimensioning the components for gate resistances, it is necessary to consider the average power dissipation in these resistors due to the switching of the power transistor as explained in the losses-based external gate resistor selection, and the pulse power capability of the component.

## 8.4 Dead-time resistor selection

While choosing a dead-time resistor, the minimum pulse-width that can occur during an operation must be considered.. If the minimum pulse-width has values similar to the dead-time, excessive diode conduction can occur. This will lead to loss of efficiency and in the case of SiC switches potentially damage the device. Therefore, it is recommended to keep the dead-time reasonably smaller than the minimum pulse-width, taking into account the rise and fall time, as well as the channel propagation delay.

## 8.5 Power dissipation estimation

### 8.5.1 Gate driver

The gate driver input-side losses are dominated by the quiescent losses, which are calculated by:

$$P_{Q1} = V_{VCC1} \cdot I_{Q1} \quad (4)$$

The gate driver output-side losses for each channel consist of the quiescent current losses,  $P_{Q2A/B}$  at nominal switching frequency and no load, the sourcing losses,  $P_{source,A/B}$  and the sinking losses  $P_{sink,A/B}$

$$P_{OUT, A/B} = P_{Q2, A/B} + P_{source, A/B} + P_{sink, A/B} \quad (5)$$

The quiescent losses on the output side,  $P_{Q2,A/B}$  can be calculated by:

$$P_{Q2, A/B} = (V_{VCC2A/B} - V_{VEE2A/B}) \cdot I_{Q2} \quad (6)$$

The turn-on losses,  $P_{source,A/B}$ , and turn-off losses,  $P_{sink,A/B}$ , can be estimated using the resistive voltage divider between the internal resistance of the gate driver's output stage,  $R_{DSON,H}$  or  $R_{DSON,L}$ , and external gate resistor,  $R_{G,ext}$ , with the application related gate charge,  $Q_G$ , the total gate driving voltage,  $V_{VCC2A/B} - V_{VEE2A/B}$ , and switching frequency,  $f_{sw}$ :

$$P_{source, A/B} = \frac{1}{2} Q_G \cdot f_{sw} \cdot (V_{VCC2A/B} - V_{VEE2A/B}) \cdot \frac{R_{DSON,H}}{R_{DSON,H} + R_{G,ext, ON} + R_{G,int}} \quad (7)$$

$$P_{sink, A/B} = \frac{1}{2} Q_G \cdot f_{sw} \cdot (V_{VCC2A/B} - V_{VEE2A/B}) \cdot \frac{R_{DSON,L}}{R_{DSON,L} + R_{G,ext, OFF} + R_{G,int}}$$

External components that surround the gate driver can heat up the IC. Mere calculation of losses and the theoretical junction temperature is not sufficient for a proven gate driver circuit design. Verification by measurement is required

to prevent unexpected effects in the application. Hotspots can be identified, for example, by using an infrared camera.

### 8.5.2 External gate resistor

The losses in the gate resistor for turn-on,  $R_{G,ext,ON}$ , and the gate resistor for turn-off,  $R_{G,ext,OFF}$ , can be estimated using the same resistive voltage divider formed by the resistances in the source and the sink path of the gate current using the following equation:

$$P_{source,ext} = \frac{1}{2} Q_G \cdot f_{sw} \cdot (V_{VCC2} - V_{VEE2}) \cdot \frac{R_{G,ext,ON}}{R_{DSON,H} + R_{G,ext,ON} + R_{G,int}} \quad (8)$$

$$P_{sink,ext} = \frac{1}{2} Q_G \cdot f_{sw} \cdot (V_{VCC2} - V_{VEE2}) \cdot \frac{R_{DSON,L}}{R_{DSON,L} + R_{G,ext,OFF} + R_{G,int}}$$

### 8.6 Layout guidelines

Having a well-designed PCB layout is crucial to achieve optimal performance of the gate driver. This ensures that the entire power electronic converter is operating at its best. Creating a well-designed PCB layout requires a certain level of attention and consideration to specific key factors. The following key points should be considered while designing the PCB layout using 2ED314xMC12L gate drivers:

- The low ESR, low ESL type decoupling capacitor on the input side, must be placed close to the *VCC1* and *GND1* pins and then connected to the pins such that the decoupling loop is as short as possible. Similarly, the decoupling capacitors on the output side should be placed close to the *VCC2A/B* and *VEE2A/B* pins and connected to the pins with a short connection
- It is crucial to minimize the physical area of the gate current loop that carries the current for charging and discharging the gate of the power transistor. The gate loop contains traces with high *dv/dt* and *di/dt* and having a short loop minimizes noise from the turn-on and off of the gates. A short loop also minimizes the stray inductance of the gate loop and helps improve the switching performance. To accomplish a short gate loop, the gate driver should be positioned near the power transistor, and the decoupling capacitors that store the energy for high peak currents should be located in close proximity to the gate driver
- To reduce the stray inductance of the gate loop even further, wide traces can be used for the traces in the gate loop. The forward path and the return path of the currents can be routed parallel to each other on the same PCB layer, or overlapping each other on adjacent PCB layer, to achieve the least amount of stray inductance
- In case of a unipolar power supply, the *VEE2A/B* pin of the gate driver should be connected to the Kelvin source/emitter pin of the power transistor, if available. If the Kelvin pin is not available then the connection to the source/emitter should be as short as possible, starting from the device pin, in order to avoid the high current from the power transistor from flowing into the gate loop
- The area below the body of the gate driver package should be kept free of any traces to ensure the integrity of the safety isolation between the input and output side
- It is recommended that the input signals of the gate driver connected to the *INA* and *INB* pins be kept away from any noisy traces. Although the 2ED314xMC12L comes with an integrated input filter that can filter high frequency noise on the input signal, an external RC filter with a small time constant can be placed close to these pins for enhanced filtering. Additionally, a ground plane is recommended below the input signal traces to shield the signals from noise
- The gate driver IC experiences power dissipation when the system is operating as explained in the previous chapters. This heat generated in the device is dissipated mostly via the PCB. Maximizing the copper area connected to the *VEE2A/B* pins is recommended to effectively dissipate the heat from the gate driver through the PCB

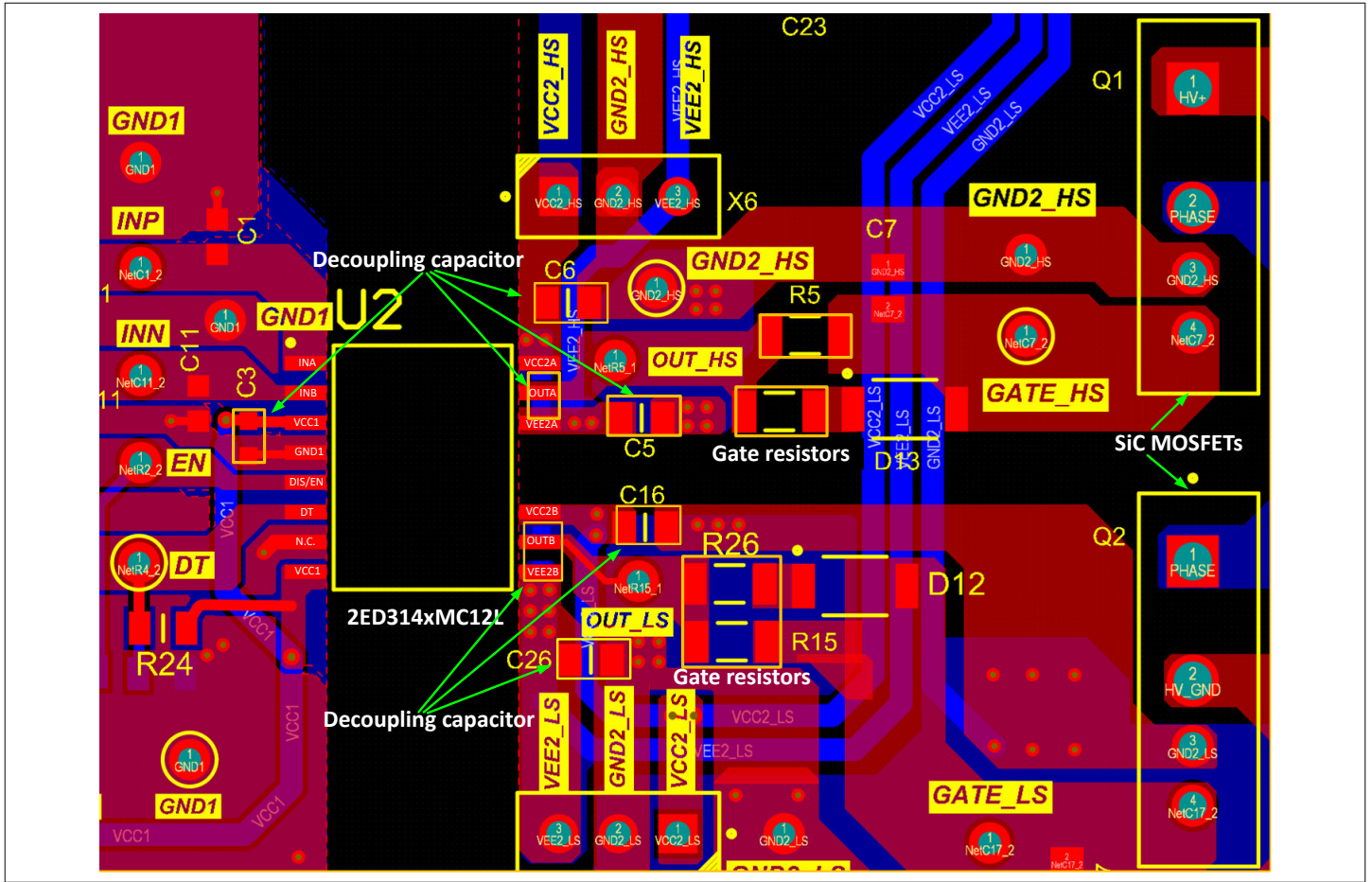

**Figure 44** Sample PCB layout showing the positioning of the decoupling capacitors

Figure 44 shows the placement of the decoupling capacitors, gate resistors and SiC MOSFETs

## 9 Related products

**Note:** Please consider the gate driver IC power dissipation and insulation requirements for the selected power switch and operating condition.

| Product group                   | Product name                       | Description  |
|---------------------------------|------------------------------------|--|
| TRENCHSTOP™<br>IGBT Discrete    | <a href="#">IKWH40N65WR6</a>       | 650 V, 40 A IGBT with anti-parallel diode in TO-247-3-HCC                |
|                                 | <a href="#">IHW30N160R5</a>        | 1600 V, 30 A IGBT Discrete with anti-parallel diode in TO-247            |
|                                 | <a href="#">IKW15N120CS7</a>       | 1200 V IGBT7 S7, 15 A IGBT with anti-parallel diode in TO247             |
|                                 | <a href="#">IKQ75N120CS7</a>       | 1200 V IGBT7 S7, 75 A IGBT with anti-parallel diode in TO247-3           |
| CoolSiC™ SiC<br>MOSFET Discrete | <a href="#">IMBF170R1K0M1</a>      | 1700 V, 1000 mΩ SiC MOSFET in TO-263-7 with extended creepage            |
|                                 | <a href="#">IMZA120R040M1H</a>     | 1200 V, 40 mΩ SiC MOSFET in TO247-4 package                              |
|                                 | <a href="#">IMZA120R014M1H</a>     | 1200 V, 14 mΩ SiC MOSFET in TO247-4 package                              |
|                                 | <a href="#">IMBG120R030M1H</a>     | 1200 V, 30 mΩ SiC MOSFET in TO-263-7 package                             |
|                                 | <a href="#">IMYH200R012M1H</a>     | 2000 V, 12 mΩ SiC MOSFET in TO-247-PLUS with high creepage and clearance |
| CoolSiC™ SiC<br>MOSFET Module   | <a href="#">FS33MR12W1M1H_B11</a>  | EasyPACK™ 1B 1200 V, 33 mΩ sixpack module                                |
|                                 | <a href="#">FF17MR12W1M1H_B11</a>  | EasyDUAL™ 1B 1200 V, 17 mΩ half-bridge module                            |
|                                 | <a href="#">FF4MR12W2M1H_B11</a>   | EasyDUAL™ 2B 1200 V, 4 mΩ half-bridge module                             |
|                                 | <a href="#">F4-17MR12W1M1H_B11</a> | EasyPACK™ 1B 1200 V, 17 mΩ fourpack module                               |
| TRENCHSTOP™<br>IGBT Modules     | <a href="#">F4-100R17N3E4</a>      | EconoPACK™ 3 1700 V, 100 A fourpack IGBT module                          |
|                                 | <a href="#">F4-200R17N3E4</a>      | EconoPACK™ 3 1700 V, 200 A fourpack IGBT module                          |
|                                 | <a href="#">FP10R12W1T7_B11</a>    | EasyPIM™ 1B 1200 V, 10 A three phase input rectifier PIM IGBT module     |
|                                 | <a href="#">FS100R12W2T7_B11</a>   | EasyPACK™ 2B 1200 V, 100 A sixpack IGBT module                           |
|                                 | <a href="#">FP150R12KT4_B11</a>    | EconoPIM™ 3 1200 V three-phase PIM IGBT module                           |
|                                 | <a href="#">FS200R12KT4R_B11</a>   | EconoPACK™ 3 1200 V, 200 A sixpack IGBT module                           |

10 Package dimensions

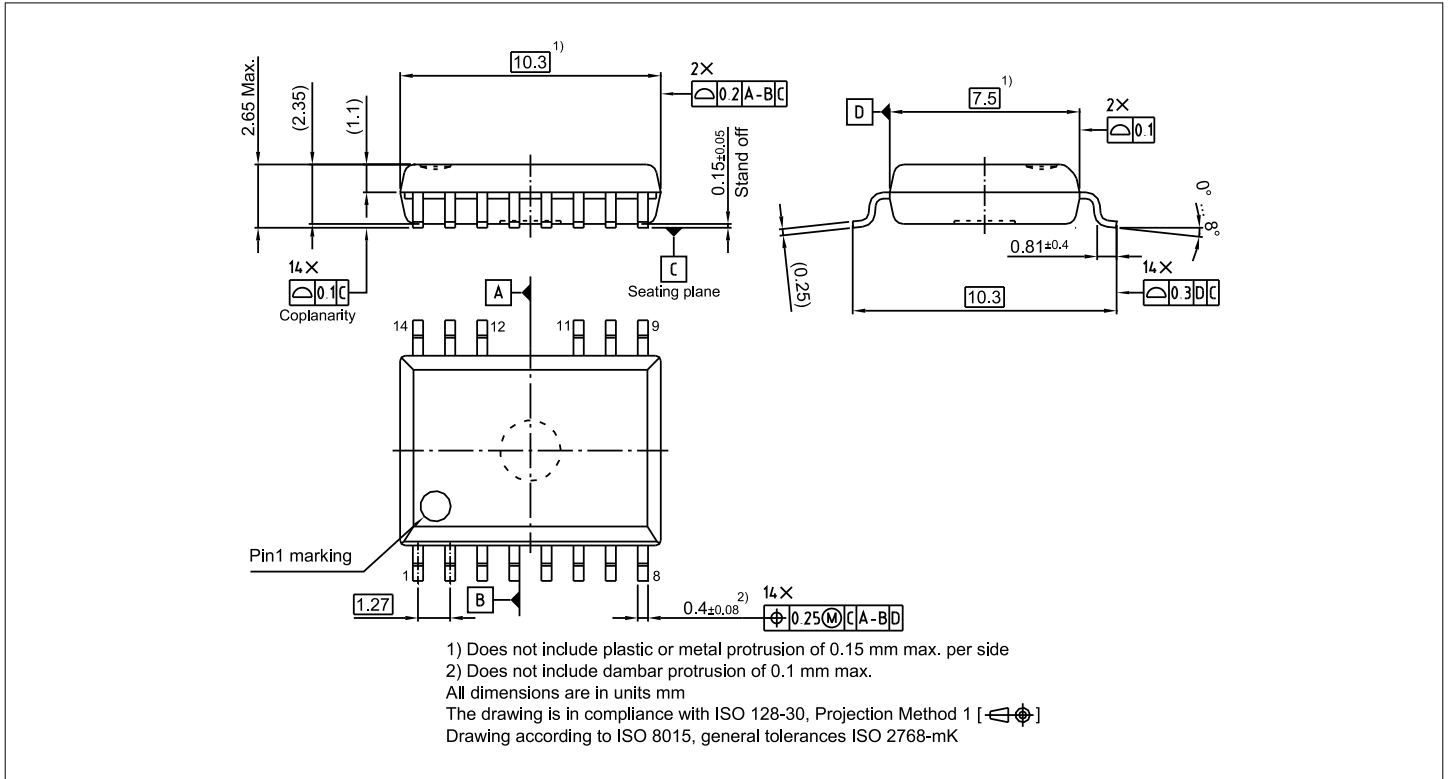

Figure 45 DSO-14-71 outline

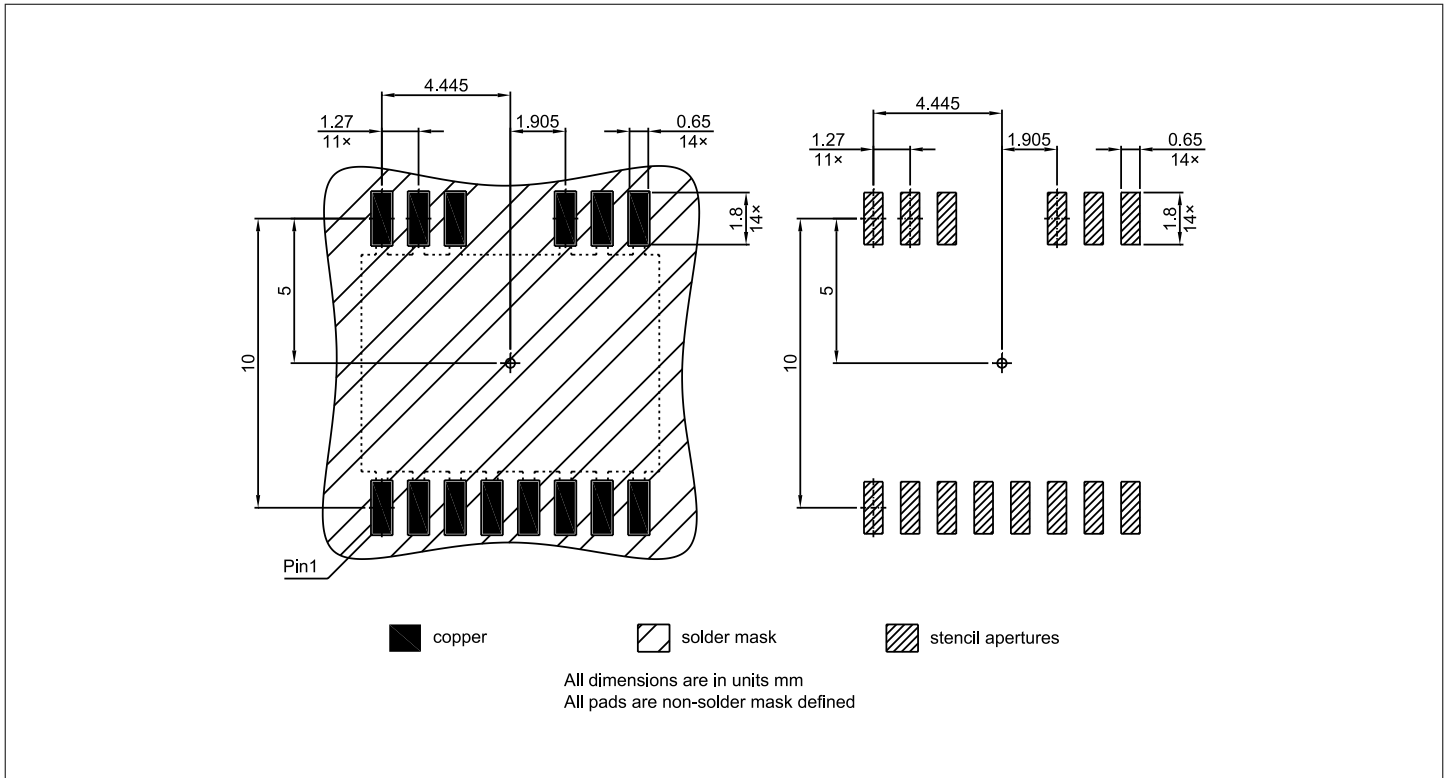

Figure 46 DSO-14-71 recommended footprint

**Revision history**

| <b>Document version</b> | <b>Date of release</b> | <b>Description of changes</b>   |
|-------------------------|------------------------|---|
| v1.00                   | 2024-06-12             | <ul style="list-style-type: none"><li>Initial official release</li></ul>  |
| v1.10                   | 2024-07-17             | <ul style="list-style-type: none"><li>Updated <math>t_{\text{SKEW\_ON,P-P}}</math>, <math>t_{\text{SKEW\_OFF;P-P}}</math>, <math>t_{\text{SKEW\_ON,Ch-Ch}}</math>, <math>t_{\text{SKEW\_OFF,Ch-Ch}}</math>, <math>t_{\text{SKEW+}}</math> parameter names</li></ul> |
| v1.20                   | 2024-09-02             | <ul style="list-style-type: none"><li>Updated graphs for better visibility</li><li>Added channel-to-channel isolation voltage</li></ul>   |
| v1.30                   | 2025-01-16             | <ul style="list-style-type: none"><li>Updated the IEC60747-17 certification status and number</li><li>Corrected the typographical error in Figure 2</li><li>Updated Figure 44</li></ul>   |
| v1.40                   | 2026-01-28             | <ul style="list-style-type: none"><li>Editorial changes in Table 1</li></ul>  |

## Trademarks

All referenced product or service names and trademarks are the property of their respective owners.

**Edition 2026-01-28**

**Published by**

**Infineon Technologies AG**

**81726 Munich, Germany**

**© 2026 Infineon Technologies AG**

**All Rights Reserved.**

**Do you have a question about any aspect of this document?**

**Email: [erratum@infineon.com](mailto:erratum@infineon.com)**

**Document reference**

**IFX-ngj1689156282272**

## Important notice

The information given in this document shall in no event be regarded as a guarantee of conditions or characteristics ("Beschaffheitsgarantie").

With respect to any examples, hints or any typical values stated herein and/or any information regarding the application of the product, Infineon Technologies hereby disclaims any and all warranties and liabilities of any kind, including without limitation warranties of non-infringement of intellectual property rights of any third party.

In addition, any information given in this document is subject to customer's compliance with its obligations stated in this document and any applicable legal requirements, norms and standards concerning customer's products and any use of the product of Infineon Technologies in customer's applications.

The data contained in this document is exclusively intended for technically trained staff. It is the responsibility of customer's technical departments to evaluate the suitability of the product for the intended application and the completeness of the product information given in this document with respect to such application.

## Warnings

Due to technical requirements products may contain dangerous substances. For information on the types in question please contact your nearest Infineon Technologies office.

Except as otherwise explicitly approved by Infineon Technologies in a written document signed by authorized representatives of Infineon Technologies, Infineon Technologies' products may not be used in any applications where a failure of the product or any consequences of the use thereof can reasonably be expected to result in personal injury.