

XENSIV™ TLE4978

Hall current sensor

Simplify current sensing with integrated safety: ASIL-B classified, high bandwidth, highly precise for high-frequency systems in automotive & industrial applications

Our XENSIV™ TLE4978 family of highly precise coreless current sensors is designed with the hybrid Hall + coil architecture. They deliver bi-directional AC/DC measurements with simultaneous over-current and zero-crossing detection (OCD & ZCD). Developed in accordance with ISO 26262 for safety requirements rated up to ASIL-B, its high 9 MHz bandwidth offers exceptional accuracy across automotive, industrial, and telecom applications. This enables you to simplify system design and reduce component count. You can accelerate time-to-market with a single certified solution that ensures reliable power management and safety protection.

The XENSIV™ TLE4978 current sensor comes in a PG-DSO-16 300 mil, Grade 0 wide-body package to meet basic and reinforced isolation requirements. This pre-calibrated, highly accurate AC/DC current sensor features a high 9 MHz bandwidth with pre-programmed sensitivity. With exceptionally low noise (typ. 38 mARMS), minimal sensitivity error over temperature and lifetime (max. ±1.2%), and low offset error over temperature and lifetime (max. 200 mA), it sets a new standard in coreless current sensing technology.

For modifying the device settings, the OCD thresholds can be adjusted using an external resistive divider and programming.

Potential applications

DC-DC converters, On-board charging, EV charging, PV inverter, Battery charging & discharging, Servo drives, SMPS, Data center



Key features – 5 V variant

- High bandwidth of 9 MHz
- Current measurement from 45 A to 67.5 A
- Supply voltage: 5 V
- Dedicated pin for the OCD & ZCD
- Operating ambient temperature: -40°C to 150°C (Grade 0)
- ASIL-B-classified
- DSO-16 300 mil package with basic isolation and reinforced isolation

Key benefits

- High versatility for different power ranges, with OCD & ZCD programming capabilities
- High bandwidth, enabling use across a wide range of applications
- Highly precise measurement over temperature and lifetime
- Exceptional low-current measurement capabilities, thanks to low noise performance
- Easy integration with pre-calibrated and pre-programmed sensitivity

Block diagram

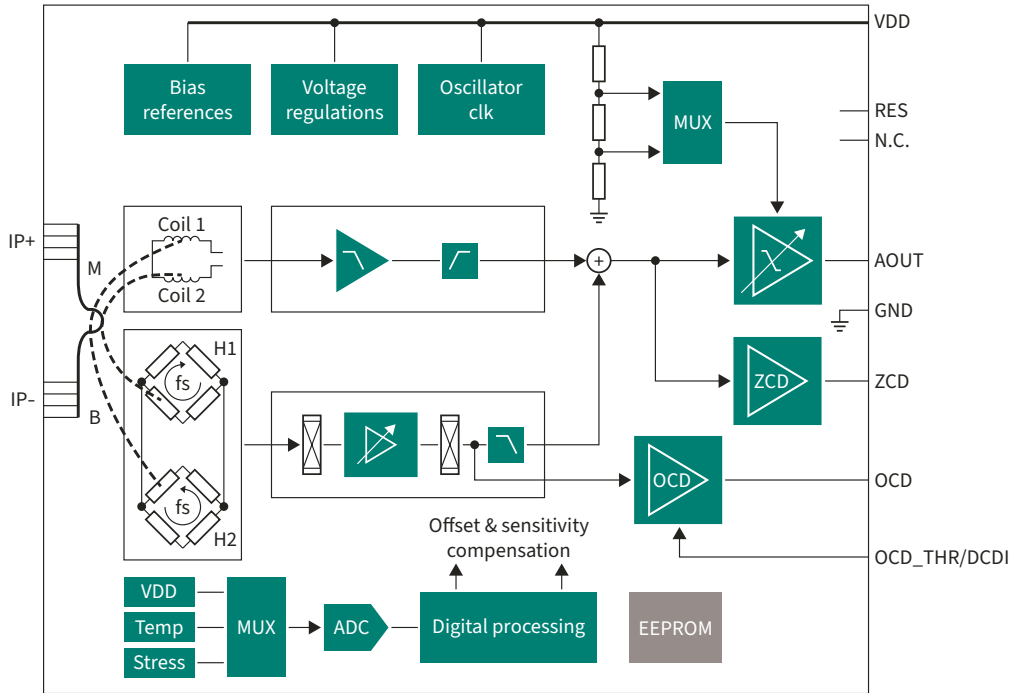

Product table (5V variant)

Product	Supply [V]	Current range [Apeak]	Sensitivity [mV/A]	Output mode	Isolation class	Package
TLE4978-R040W5-O-S0010	5.0	45	48.75	Single-ended	Basic/Reinforced	PG-DSO-16
TLE4978-R050W5-O-S0010	5.0	56	39	Single-ended	Basic/Reinforced	PG-DSO-16
TLE4978-R060W5-O-S0010	5.0	67.5	32.5	Single-ended	Basic/Reinforced	PG-DSO-16

Published by
 Infineon Technologies AG
 Am Campeon 1-15, 85579 Neuburg
 Germany

© 2026 Infineon Technologies AG.
 All rights reserved.

Public

Date: 03/2026

Important notice
 Products are sold or provided and delivered by Infineon Technologies AG and its affiliates (“Infineon”) subject to the terms and conditions of the frame supply contract or other written agreement(s) executed by a customer and Infineon or, in the absence of the foregoing, the applicable Sales Conditions of Infineon. General terms and conditions of a customer or deviations from applicable Sales Conditions of Infineon shall only be binding for Infineon if and to the extent Infineon has given its express written consent.

To the fullest extent permissible pursuant to applicable law, with respect to any information given in this document or in any associated

documentation, Infineon disclaims all warranties and liabilities of any kind, whether express or implied, including but not limited to any warranties of merchantability, suitability of the products for the intended application or the specific use, or non-infringement of third-party rights.

Subject to the development and release of the products for series supply by Infineon, the technical specifications of the products are set forth in the relevant final datasheet provided by Infineon and, if any, agreed and signed specifications. Infineon’s customers are required to evaluate the suitability of the products for the intended application or specific use.

The information given in this document is subject to change by Infineon at any time without notice.



Scan QR code and explore offering
www.infineon.com