

Eval-1EDR3146HQE-SiC

Evaluation board description and getting started guide

About this document

Scope and purpose

This user guide is intended to introduce and provide an overview of the gate driver evaluation board Eval-1EDR3146HQE-SiC with the [1EDR3146HQE](#) gate driver integrated circuits (IC), including the functionality and key features of the Infineon EiceDRIVER™ 1EDR314xHQE gate driver IC family.

The [Eval-1EDR3146HQE-SiC](#) board is designed to evaluate the functionality and capability of 1EDR3146HQE gate driver ICs.

This user guide presents only key features of the gate driver, and the datasheet should be consulted to ensure the full functionality and flexibility of the 1EDR3146HQE gate driver and Eval-1EDR3146HQE-SiC.

Intended audience

This document is intended for all technical specialists who want to evaluate the functionality, performance, and features of 1EDR3146HQE gate driver ICs. The evaluation board is intended to be used under laboratory conditions only by trained specialists.

It is a prerequisite to read the [datasheet](#) of the 1EDR3146HQE to become familiar with the parameters of the gate driver.

Evaluation Board

This board is intended to be used during the design-in process for evaluating and measuring characteristic curves, and for checking datasheet specifications.

Note: PCB and auxiliary circuits are NOT optimized for final customer design.

Important notice

Important notice

“Evaluation Boards and Reference Boards” shall mean products embedded on a printed circuit board (PCB) for demonstration and/or evaluation purposes, which include, without limitation, demonstration, reference and evaluation boards, kits and design (collectively referred to as “Reference Board”).

Environmental conditions have been considered in the design of the Evaluation Boards and Reference Boards provided by Infineon Technologies. The design of the Evaluation Boards and Reference Boards has been tested by Infineon Technologies only as described in this document. The design is not qualified in terms of safety requirements, manufacturing and operation over the entire operating temperature range or lifetime.

The Evaluation Boards and Reference Boards provided by Infineon Technologies are subject to functional testing only under typical load conditions. Evaluation Boards and Reference Boards are not subject to the same procedures as regular products regarding returned material analysis (RMA), process change notification (PCN) and product discontinuation (PD).

Evaluation Boards and Reference Boards are not commercialized products and are solely intended for evaluation and testing purposes. In particular, they shall not be used for reliability testing or production. The Evaluation Boards and Reference Boards may therefore not comply with CE or similar standards (including but not limited to the EMC Directive 2004/EC/108 and the EMC Act) and may not fulfill other requirements of the country in which they are operated by the customer. The customer shall ensure that all Evaluation Boards and Reference Boards will be handled in a way which is compliant with the relevant requirements and standards of the country in which they are operated.

The Evaluation Boards and Reference Boards as well as the information provided in this document are addressed only to qualified and skilled technical staff, for laboratory usage, and shall be used and managed according to the terms and conditions set forth in this document and in other related documentation supplied with the respective Evaluation Board or Reference Board.

It is the responsibility of the customer’s technical departments to evaluate the suitability of the Evaluation Boards and Reference Boards for the intended application, and to evaluate the completeness and correctness of the information provided in this document with respect to such application.

The customer is obliged to ensure that the use of the Evaluation Boards and Reference Boards does not cause any harm to persons or third party property.

The Evaluation Boards and Reference Boards and any information in this document is provided "as is" and Infineon Technologies disclaims any warranties, express or implied, including but not limited to warranties of non-infringement of third-party rights and implied warranties of fitness for any purpose, or for merchantability.

Infineon Technologies shall not be responsible for any damages resulting from the use of the Evaluation Boards and Reference Boards and/or from any information provided in this document. The customer is obliged to defend, indemnify and hold Infineon Technologies harmless from and against any claims or damages arising out of or resulting from any use thereof.

Infineon Technologies reserves the right to modify this document and/or any information provided herein at any time without further notice.

Safety precautions

Safety precautions

Note: Please note the following warnings regarding the hazards associated with development systems.

Table 1 Safety precautions

	<p>Warning: The DC link potential of this board is up to 900 VDC. When measuring voltage waveforms by oscilloscope, high voltage differential probes must be used. Failure to do so may result in personal injury or death.</p>
	<p>Warning: The evaluation board contains DC bus capacitors which take time to discharge after removal of the main supply. Before working on the drive system, wait five minutes for capacitors to discharge to safe voltage levels. Failure to do so may result in personal injury or death. Darkened display LEDs are not an indication that capacitors have discharged to safe voltage levels.</p>
	<p>Warning: Remove or disconnect power from the drive before you disconnect or reconnect wires, or perform maintenance work. Wait five minutes after removing power to discharge the bus capacitors. Do not attempt to service the drive until the bus capacitors have discharged to zero. Failure to do so may result in personal injury or death.</p>
	<p>Caution: Only personnel familiar with the drive, power electronics and associated machinery should plan, install, commission and subsequently service the system. Failure to comply may result in personal injury and/or equipment damage.</p>
	<p>Caution: The evaluation board contains parts and assemblies sensitive to electrostatic discharge (ESD). Electrostatic control precautions are required when installing, testing, servicing or repairing the assembly. Component damage may result if ESD control procedures are not followed. If you are not familiar with electrostatic control procedures, refer to the applicable ESD protection handbooks and guidelines.</p>
	<p>Caution: A drive that is incorrectly applied or installed can lead to component damage or reduction in product lifetime. Wiring or application errors such as undersizing the motor, supplying an incorrect or inadequate AC supply, or excessive ambient temperatures may result in system malfunction.</p>
	<p>Caution: The evaluation board is shipped with packing materials that need to be removed prior to installation. Failure to remove all packing materials that are unnecessary for system installation may result in overheating or abnormal operating conditions.</p>

Table of contents

About this document..... 1

Important notice 2

Safety precautions..... 3

Table of contents 4

1 The board at a glance..... 5

1.1 Scope of supply6

1.2 Block diagram.....6

1.3 Main features6

1.4 Board parameters and technical data7

2 System and functional description 9

2.1 Getting started.....9

2.1.1 Prerequisites9

2.1.2 Power-up sequence with the on-board power supply9

2.1.3 Power-up sequence with external supply voltages10

2.2 Example: Normal operation with on-board power supply10

3 System design.....13

3.1 Schematics13

3.2 Layout14

3.3 Bill of material17

3.4 Connector details18

3.5 Test points19

4 References and appendices20

4.1 References20

4.2 Ordering information20

Revision history.....21

Disclaimer.....22

1 The board at a glance

The Eval-1EDR3146HQE-SiC evaluation board is designed to be used by design engineers to evaluate the 1EDR3146HQE EiceDRIVER™ isolated gate driver IC in a half-bridge configuration. The evaluation board can be used to evaluate other pin-compatible ICs from the EiceDRIVER™ 1EDR314xHQE gate driver family by replacing the gate driver ICs.

The board comes with two unassembled Infineon [AIMZH120R060M1T](#) CoolSiC™ 1200 V SiC Trench MOSFETs in a TO247-4 package, as seen in Figure 1. These switches can be substituted by any other desired switches, such as Infineon IGBTs, CoolSiC™ or CoolMOST™ transistors.

Details about the EiceDRIVER™ 1EDR3146HQE can be found on our product pages at <https://www.infineon.com/gdisolated> or by using the product search.

The board has a size of 85 × 56 × 28 mm³ without any power switches assembled. As the board was designed for non-continuous evaluation, such as double-pulse testing, special consideration should be taken regarding the current capabilities of the power tracks and to ensure proper cooling of the power switches. It is also recommended to add additional high-voltage bulk capacitors at the high-voltage input.

The board has a galvanically isolated on-board power supply which generates the output side positive and negative power supply voltages for the high-side and low-side gate drivers. This power supply is designed with the transformer driver IC EiceDRIVER™ Power [2EP130R](#). Detailed information on the design of gate driver isolated power supply with the 2EP130R for SiC MOSFETs can be found in the user guide of the evaluation board [EVAL-2EP130R-PR-SiC](#). The board is designed such that it is possible to deactivate the on-board power supply and the gate drivers can be supplied externally. Additionally, a linear regulator circuit generates the 3.3 V or 5 V for the input supply voltage for the gate drivers. Thus, all the supply voltages required for evaluation of the gate drivers are generated on the board.

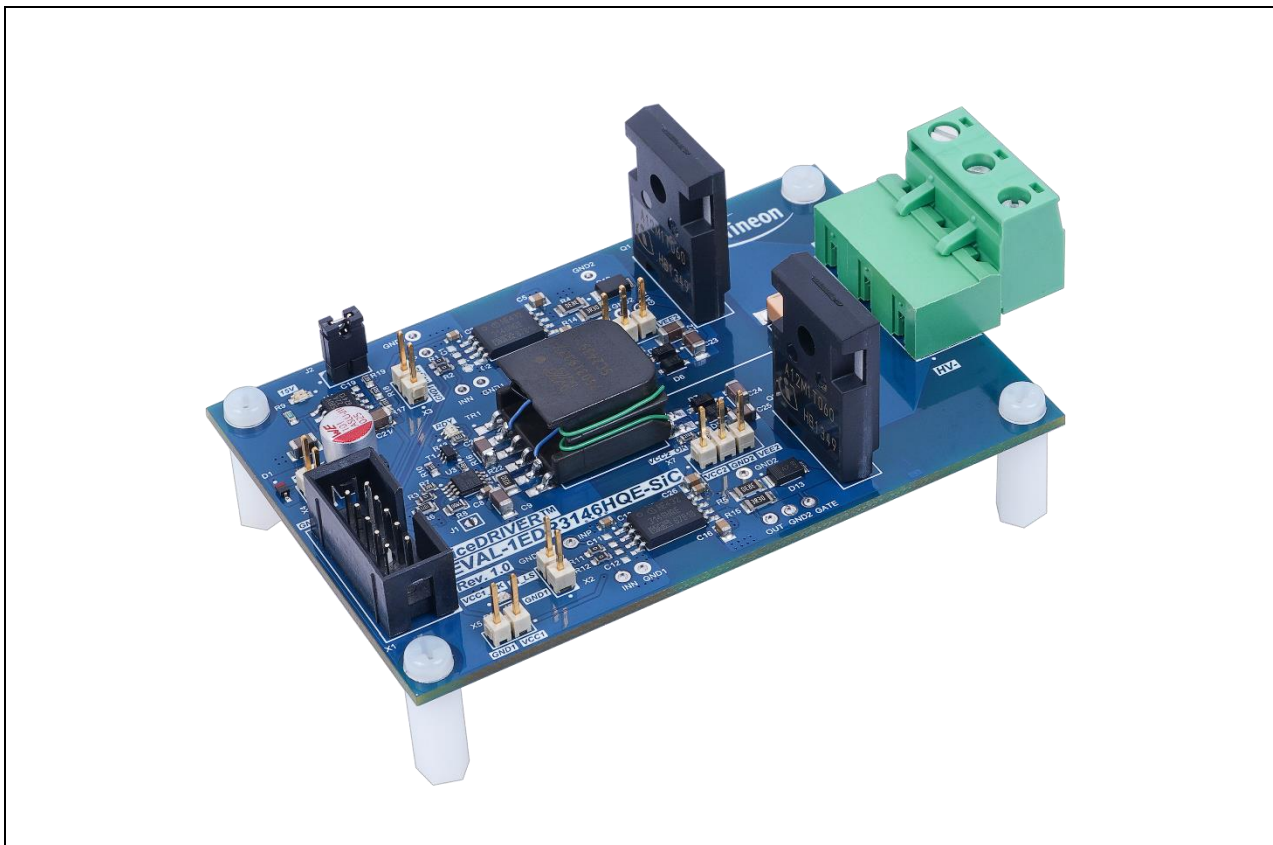

Figure 1 Eval-1EDR3146HQE-SiC evaluation board

1.1 Scope of supply

The delivery contains:

- The evaluation board Eval-1EDR3146HQE-SiC
- Two AIMZH120R060M1T CoolSiC™ 1200 V SiC Trench MOSFETs for assembly

1.2 Block diagram

Figure 2 shows the block diagram of the Eval-1EDR3146HQE-SiC evaluation board.

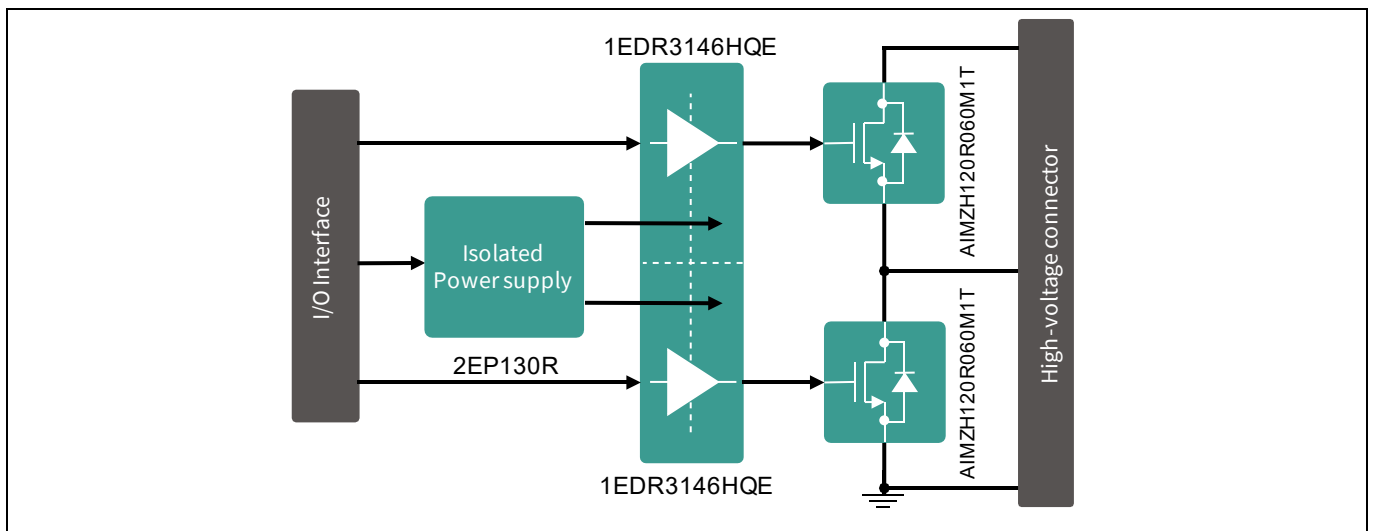

Figure 2 Eval-1EDR3146HQE-SiC evaluation board block diagram

1.3 Main features

The [Eval-1EDR3146HQE-SiC](#) is an evaluation board for the [1EDR3146HQE](#) gate driver ICs. It is designed in a half-bridge configuration with a 900 V maximum blocking capability across the power terminals. The board is designed for easy measurement and configuration of the gate driver parameters, and the main features of the board and gate driver include:

- 35 V absolute maximum output supply voltage
- ± 6.5 A typical output current
- Output UVLO referenced to *GND2* pin for optimal protection with bipolar supply voltages
- Active shutdown
- Very high common-mode transient immunity CMTI > 300 kV/ μ s
- 40 ns typical propagation delay
- Tight IC-to-IC propagation delay matching
- 3.3 V and 5 V input supply voltage
- PG-LDSO-8 wide body package with >8 mm creepage
- Gate driver safety certification:
 - UL 1577 recognized with $V_{ISO, test} = 6840$ V (rms) for 1 s, $V_{ISO} = 5700$ V (rms) for 60 s
 - Reinforced isolation as per IEC 60747-17 with $V_{IORM} = 1767$ V (planned)
- Infineon AIMZH120R060M1T CoolSiC™ 1200 V SiC Trench MOSFETs in PG-TO247-4 (unassembled)

The on-board isolated power supply is designed with the 2EP130R transformer driver IC. The main features of 2EP130R are:

- Wide input voltage range 4.5 V to 20 V
- Wide range of switching frequency from 50 kHz to 695 kHz
- High accuracy duty cycle adjustment from 10% to 50%
- Peak-current controlled soft-start
- Over-current and over-temperature protection
- Ready signal to indicate successful completion of soft-start

1.4 Board parameters and technical data

The absolute maximum ratings are summarized in Table 2.

Table 2 Absolute maximum ratings

Parameter/Pin	Symbol	Conditions/Notes	Value	Unit
Diode protected isolated power supply input voltage	15V	Referenced to GND1	-0.3 ... 18	V
Input side supply voltage	VCC1	Referenced to GND1	-0.3 ... 6.5	V
Positive input for low-side gate driver	IN_LS	Referenced to GND1	-0.3 ... 17	V
Positive input for high-side gate driver	IN_HS	Referenced to GND1	-0.3 ... 17	V
Ready output for power supply	RDY	Ready state of the on-board power supply circuit	-0.3 ... 6.5	V
Clock signal for bypass mode of power supply	PWM_PSU		-0.3 ... 6.5	V
Reserved	.res	Reserved for future use		
DC-link voltage	HV+	Referenced to HV- power terminal. Limited by component ratings and design clearances. For voltages above 60 V, special safety measures should be taken	-0.2 ... 900	V
Half-bridge mid-point connection	PHASE	Midpoint connection for the half-bridge	-0.2 ... 900	V
High power ground terminal	HV-	Ground connection for the high-power connection	-	-
Output side positive supply voltages	VCC2	Referenced to VEE2. Not to be used with on-board power supply	-0.3 ... 35	V
Output side negative supply voltages	VEE2	Referenced to GND2. Not to be used with on-board power supply	-35 ... 0.3	V
Phase peak current	I_{out}	Pulse current	40	A
Pulse width	t_{pulse}	Maximum ON pulse length for double-pulse tests. Power dissipation should be considered	100	μ s

The recommended operating conditions are summarized in Table 3.

Table 3 Recommended operating conditions and supply for 3.3 V

Parameter/Pin	Symbol	Conditions/Notes	Value			Unit
			Min.	Typ.	Max	
Isolated power supply input voltage	15V	Referenced to GND1	14.5	15.3	16	V
Input side supply voltage	VCC1	Referenced to GND1	3.2	3.3	3.5	V
Positive input for low-side gate driver	IN_LS	Referenced to GND1	-0.1	VCC1	VCC1+0.1	V
Positive input for high-side gate driver	IN_HS	Referenced to GND1	-0.1	VCC1	VCC1+0.1	V
Reset input for over current protection circuit	RST	Referenced to GND1	-0.1	VCC1	VCC1+0.1	V
DC-link voltage	HV+	Referenced to HV- power terminal. Limited by component ratings and design clearances. For voltages above 42 V, special safety measures should be taken	25	-	800	V
Output side positive supply voltages	VCC2	Referenced to VEE2. Not to be used with on-board power supply	15	18	20	V
Output side negative supply voltages	VEE2	Referenced to GND2. Not to be used with on-board power supply	-5	-3	0	V

2 System and functional description

2.1 Getting started

The Eval-1EDR3146HQE-SiC is optimized to be used with both 5 V and 3.3 V voltages for the input side supply of the gate drivers, VCC1. The board also has a linear power supply circuit that generates a 5 V or 3.3 V required for the input side voltage, VCC1. However, it is important to note that the threshold values for the primary-side input signals are independent of the VCC1 supply voltage.

It is recommended to use the board with the on-board isolated power supply for the output side supply voltages of the high-side and low-side gate drivers. For a nominal input voltage of +15.3 V, this power supply will provide a bipolar +18 V/-2.6 V supply voltage for the output sides for both the high-side and the low-side gate drivers.

2.1.1 Prerequisites

- Assembled external high-voltage decoupling capacitor (>100 μ F) across the high-voltage power terminals: X99 (*HV+* and *HV-*)
- Low voltage power supply for supplying the input-side power supply circuit, capable of supplying >15 V, 100 mA: X4 (*15V* and *GND1*)
- Suitable function generator for double-pulse signal generation
- High-voltage power supply for supplying the power stage: X99 (*HV+* and *HV-*)
- A suitable inductive load for double-pulse testing

2.1.2 Power-up sequence with the on-board power supply

1. Connect the double-pulse signal generator to the Eval-1EDR3146HQE-SiC input pins. For evaluating the low-side switching capability, connect the signal generator to the connector X2 (*IN_LS* and *GND1*) and short the pins on the connector X3 (*IN_HS* and *GND1*). For evaluation of the high-side switching capability, connect the signal generator to X3 (*IN_HS* and *GND1*) and short X2 (*IN_LS* and *GND1*).
2. Connect one end of the inductive load to terminal X99 (*PHASE*) and the other end, depending on the double-pulse test requirements, to either X99 (*HV+*) for the low-side testing or X99 (*HV-*) for the high-side testing.
3. Supply the isolated power supply input voltage at connector X4 (*15V* and *GND1*) with 15.3 V.
4. The default input side supply voltage for the gate drivers is 3.3 V. This can be changed to 5 V by shorting the jumper J2 (*5V_EN*).
5. The default output rail-to-rail voltage of the on-board power supply is 20.5 V. This voltage is split into positive rail voltage of 18 V and negative rail voltage -2.6 V for the gate drivers. It is possible to change the ratio of the positive and negative rail voltages by changing the duty cycle resistor R8. Detailed information on splitting the rail voltage can be found in the datasheet of 2EP130R.
6. The rail-to-rail output voltage of the isolated power supply can be increased or decreased by changing the input voltage of the power supply.
7. The green LEDs D2 (*15V*), D3 (*VCC1_OK*), D4 (*RDY*), D10 (*VCC2_OK*), D11 (*VCC2_OK*) will turn on indicating that the power supply circuit is ready and all the supply voltages for the gate drivers are available.
8. Connect the high voltage power supply to the connector X99 (*HV+* and *HV-*)
9. The board is now ready for double-pulse evaluation.

2.1.3 Power-up sequence with external supply voltages

1. Connect the double-pulse signal generator to the Eval-1EDR3146HQE-SiC input pins. For evaluating the low-side switching capability, connect the signal generator to the connector X2 (*IN_LS* and *GND1*) and short the pins on the connector X3 (*IN_HS* and *GND1*). For evaluation of the high-side switching capability, connect the signal generator to X3 (*IN_HS* and *GND1*) and short X2 (*IN_LS* to *GND1*).
2. Connect one end of the inductive load to terminal X99 (*PHASE*) and the other end, depending on the double-pulse test requirements, to either X99 (*HV+*) for the low-side testing or X99 (*HV-*) for the high-side testing.
3. Deactivate the on-board power supply by shorting the solder jumper J1 and connecting pin X1 (*PWM_PSU*) to X1 (*GND1*).
4. Supply the isolated power supply input voltage at connector X4 (*15V*) and X4 (*GND1*) with 15 V. (This is required to generate the input supply voltage for the gate drivers).
5. The default input side supply voltage for the gate drivers is 3.3 V. This can be changed to 5 V by shorting the jumper J2 (*5V_EN*).
6. Supply the gate driver output supply voltages externally through the connector X6 (*VCC2*), X6 (*GND2*) and X6 (*VEE2*) for the high-side gate driver and through X7 (*VCC2*), X7 (*GND2*) and X7 (*VEE2*) for the low-side gate driver. Please note that the supply voltages for the high-side and the low-side gate drivers should be functionally isolated from each other.
7. The green LEDs D2 (*15V*), D3 (*VCC1_OK*), D10 (*VCC2_OK*), D11 (*VCC2_OK*) will turn on indicating that all the supply voltages for the gate drivers are available. The red LED D4 (*RDY*) will turn on to indicate that the on-board power supply is deactivated.
8. Connect the high-voltage power supply to the connector X99 (*HV+*) and X99 (*HV-*)
9. The board is now ready for double-pulse evaluation.

2.2 Example: Normal operation with on-board power supply

Figure 3 shows the ramp-up of the output supply voltages of the low-side gate driver at startup. The positive supply voltage and the negative supply voltage reach 18 V and -2.6 V, respectively after the soft-start.

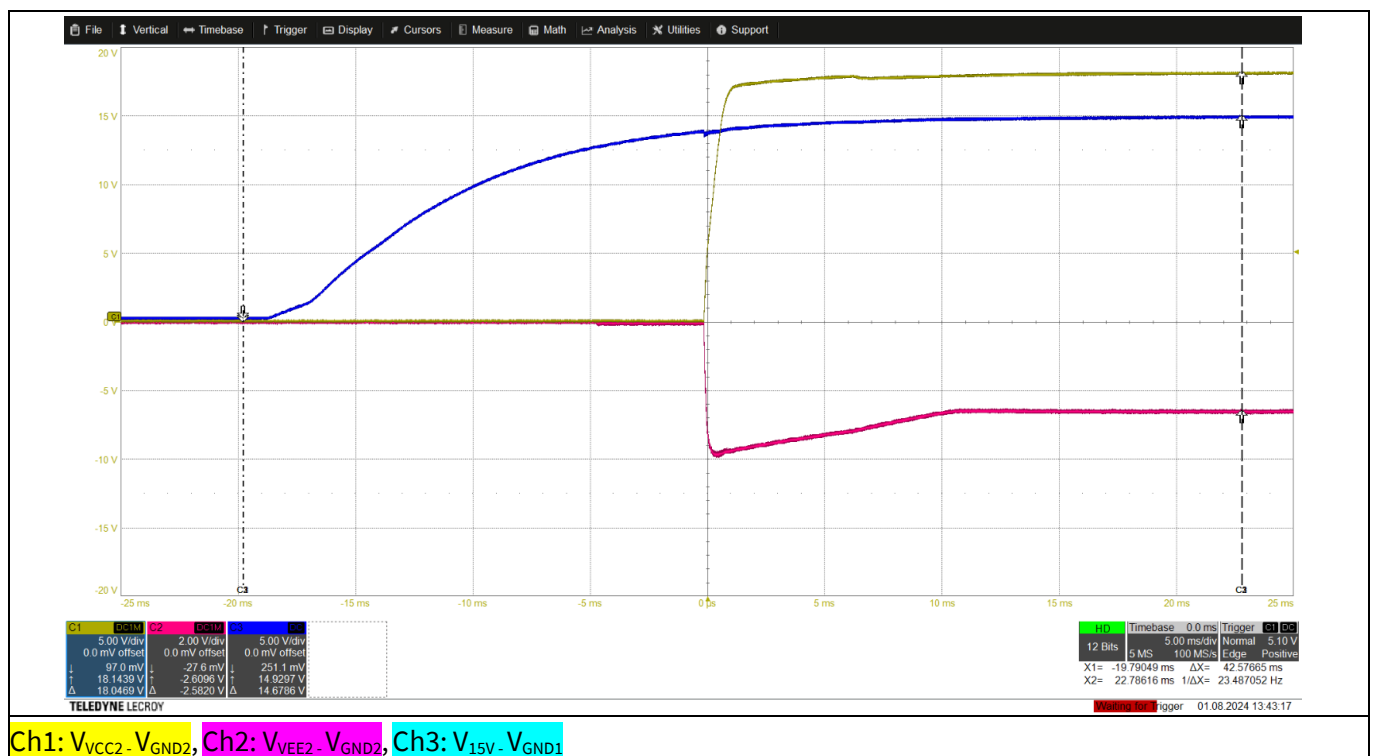

Figure 3 Eval-1EDR3146HQE-SiC – Power supply voltages startup

Figure 4, Figure 5 and Figure 6 show the Eval-1EDR3146HQE-SiC in a typical double-pulse test of the low-side CoolSiC™ MOSFET. The board was supplied with 800 V between terminals X99 (HV+) and X99 (HV-). A 200 μH load inductor was connected in parallel with the high-side CoolSiC™ MOSFET, between terminals X99 (HV+) and X99 (PHASE). The gate source signal of the low-side CoolSiC™ SiC MOSFET is shown with yellow on channel 1. Channel 2 with red shows the drain current I_D . Lastly, with blue, the drain source voltage, V_{DS} of the same MOSFET is shown on channel 3. At the end of first pulse, the drain current, I_D , is 20 A.

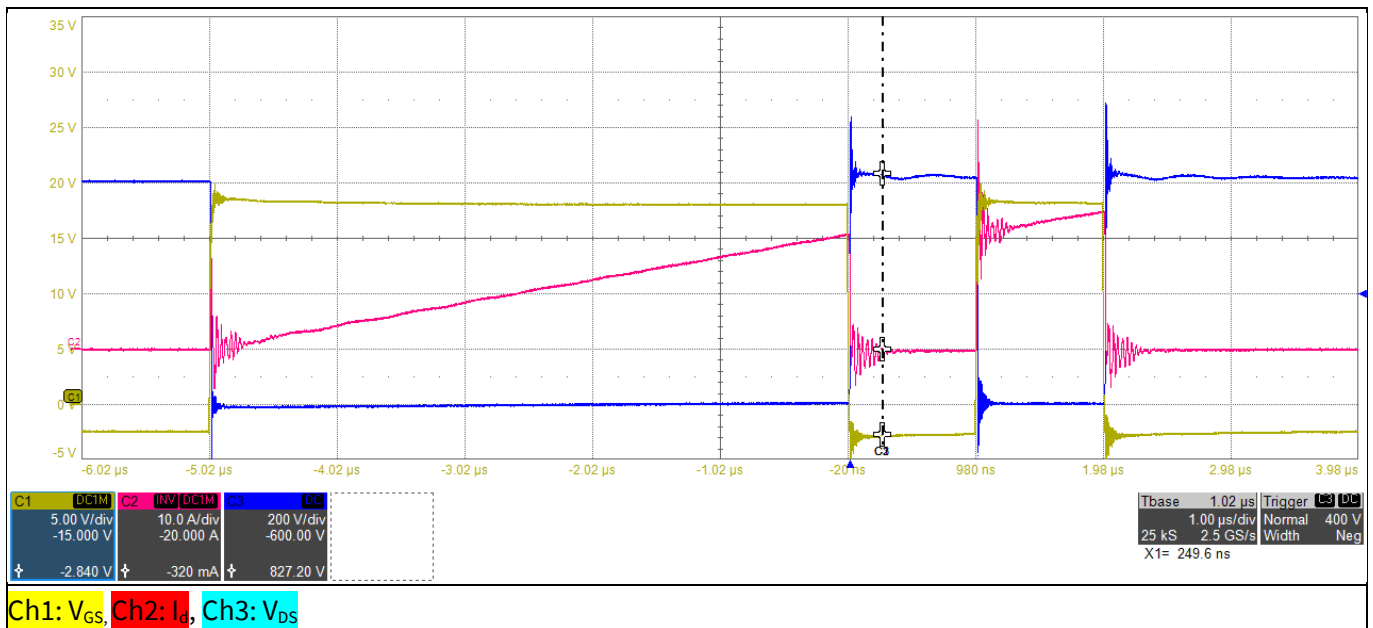

Figure 4 Eval-1EDR3146HQE-SiC – Double-pulse test of the low-side CoolSiC™ MOSFET

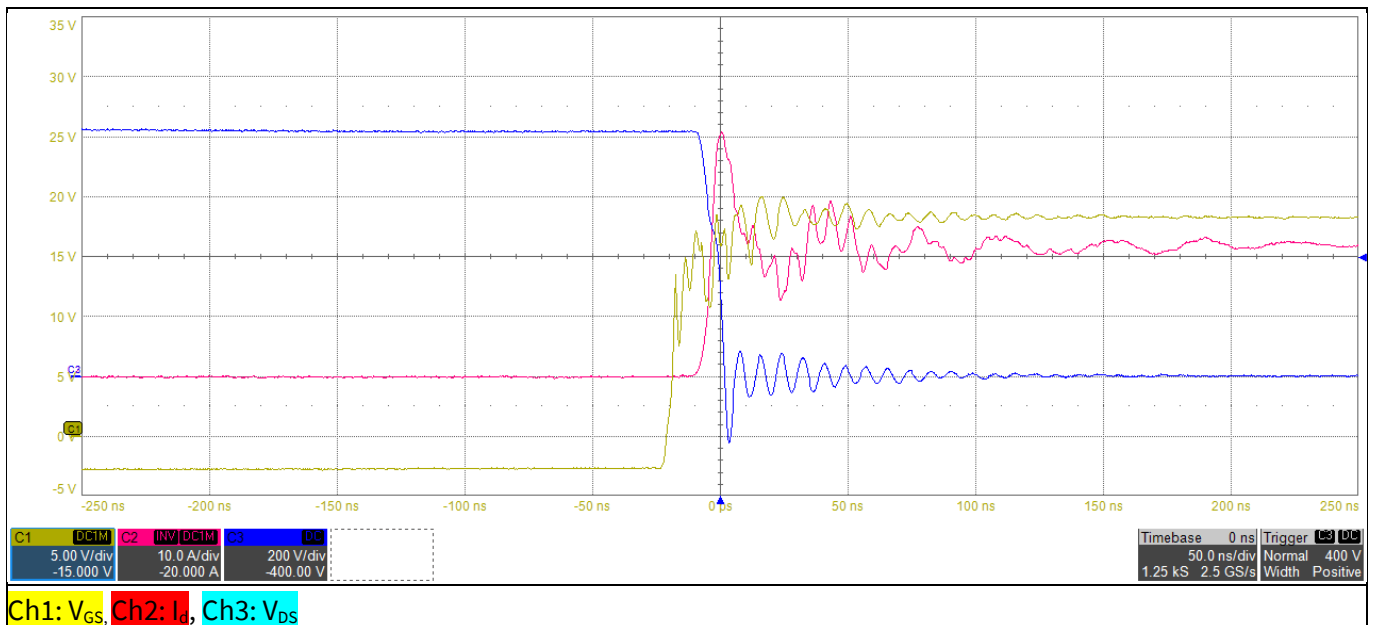

Figure 5 Eval-1EDR3146HQE-SiC – Second turn-on of the low-side CoolSiC™ MOSFET

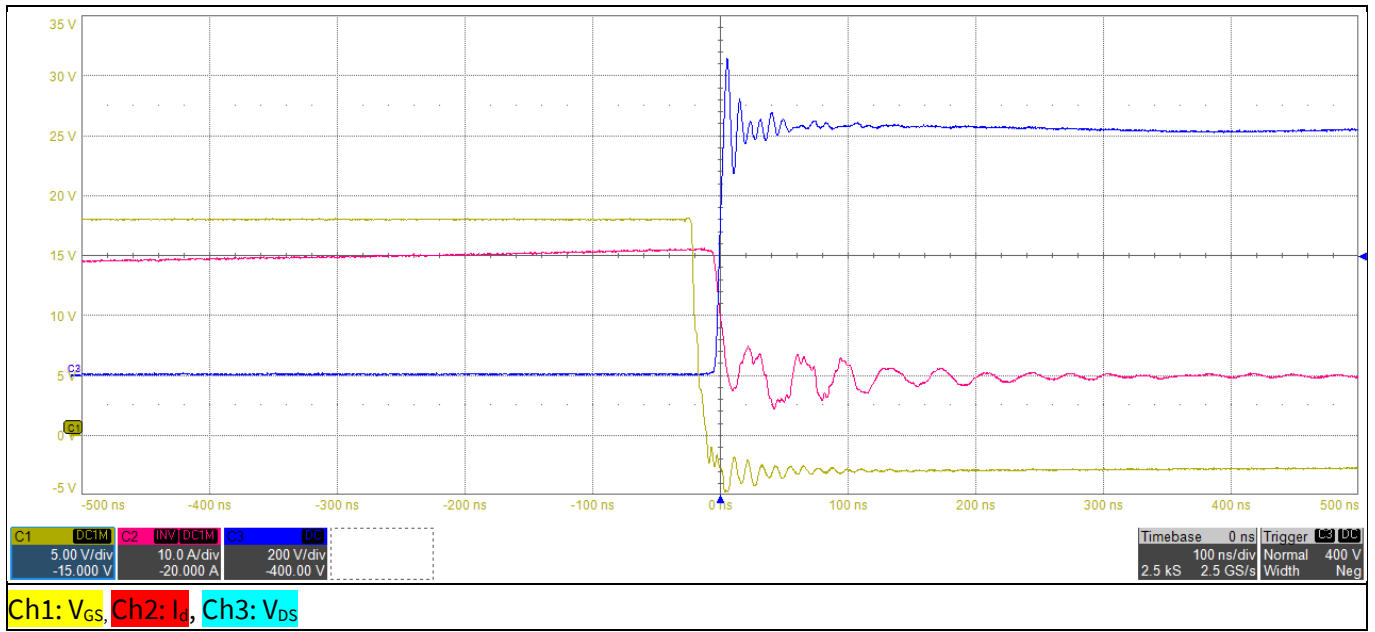

Figure 6 Eval-1EDR3146HQE-SiC – First turn-off of the low-side CoolSiC™ MOSFET

3 System design

The Eval-1EDR3146HQE-SiC evaluation board is designed to evaluate the EiceDRIVER™ 1EDR314xHQE X3-compact family gate driver ICs. To support the customer in getting started with the design, the schematics, Gerber data and Altium project files can be found on the evaluation board homepage.

3.1 Schematics

The schematics of the evaluation board is shown below.

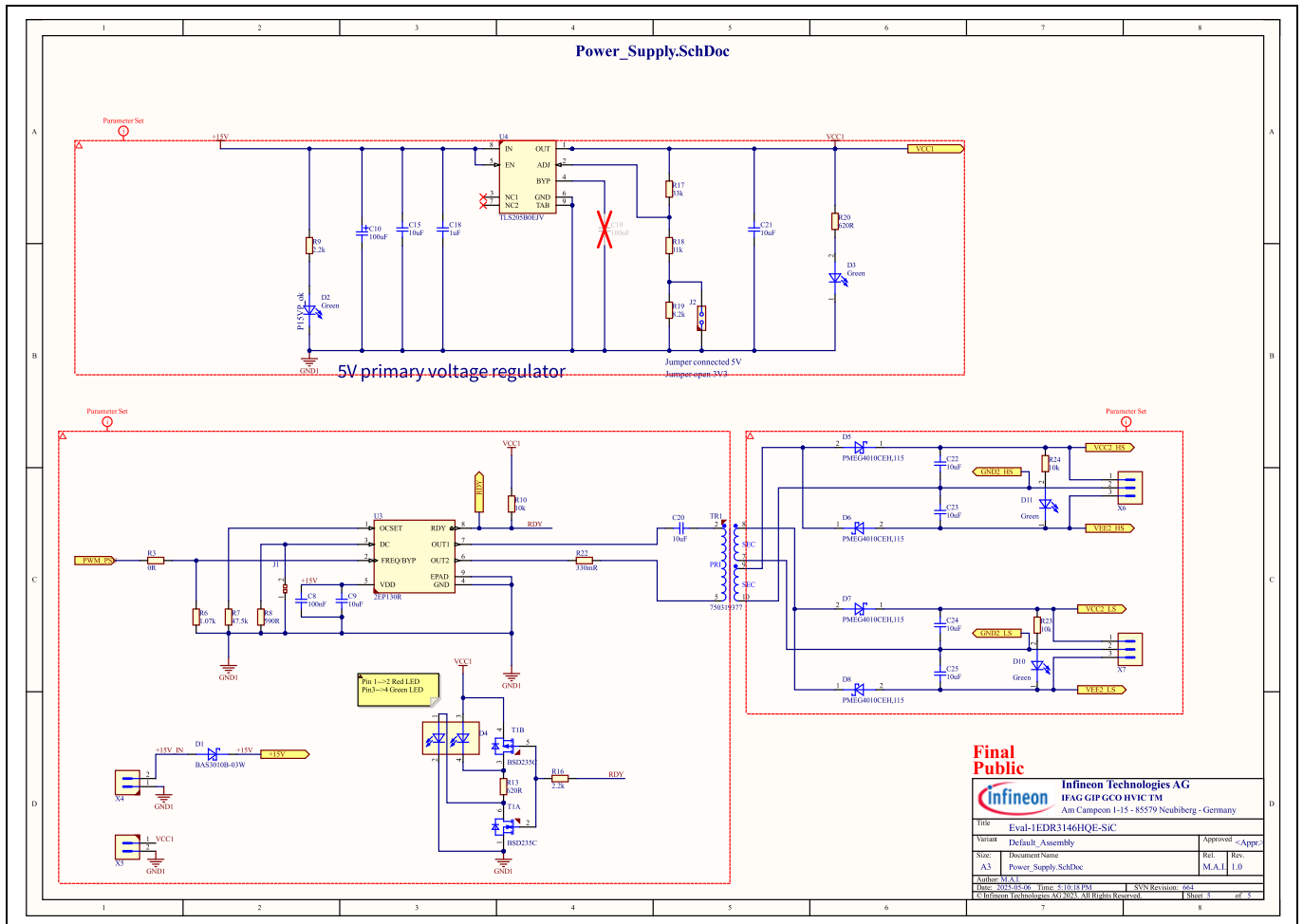

Figure 7 Power supply circuit schematic

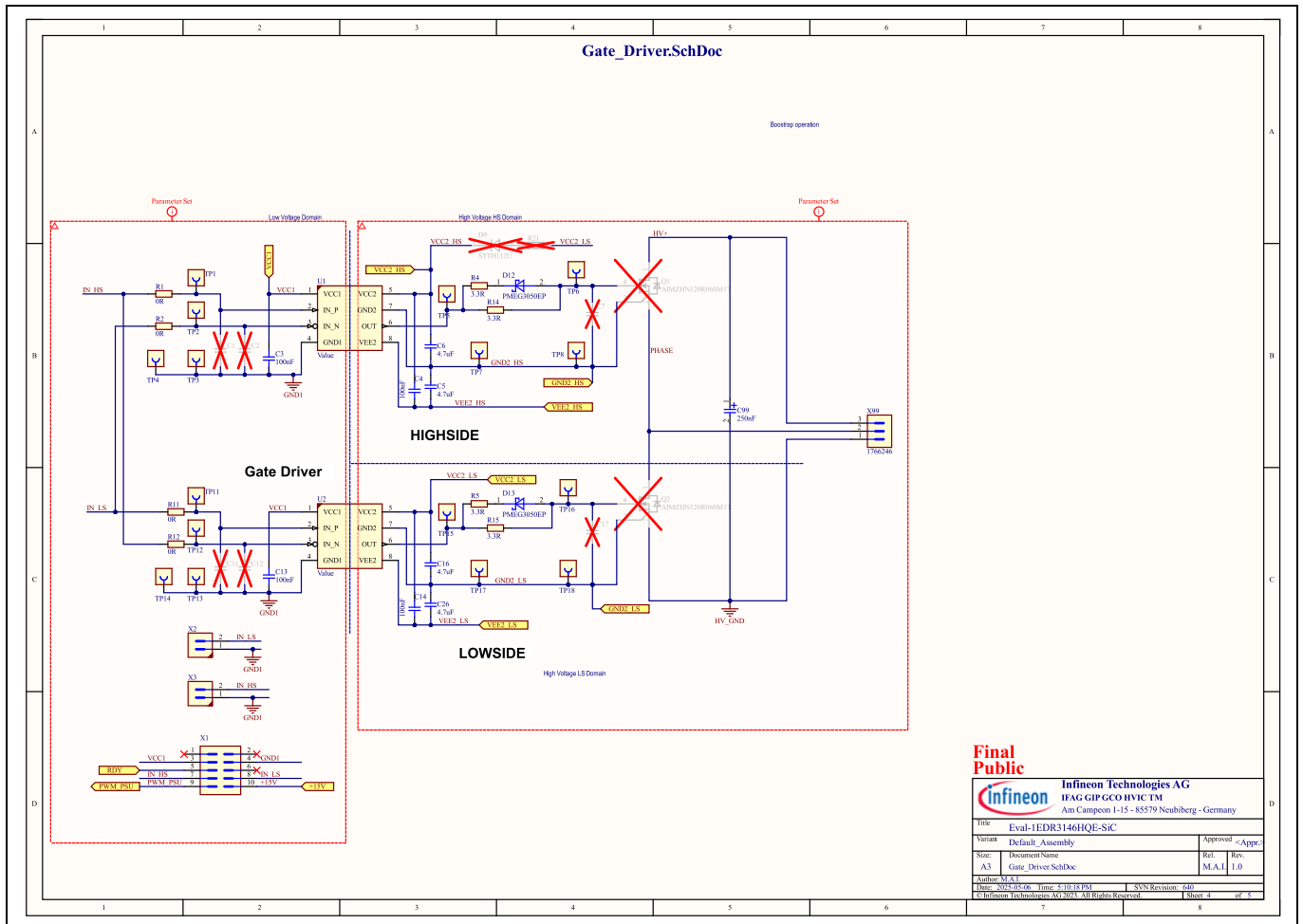

Figure 8 Gate driver circuit schematic

3.2 Layout

The evaluation board Eval-1EDR3146HQE-SiC uses a two-layer PCB with 35 μm copper thickness. The top and the bottom view of the PCB layout as well as the copper layers of the PCB are shown in the Figure 9, Figure 10, Figure 11, Figure 12.

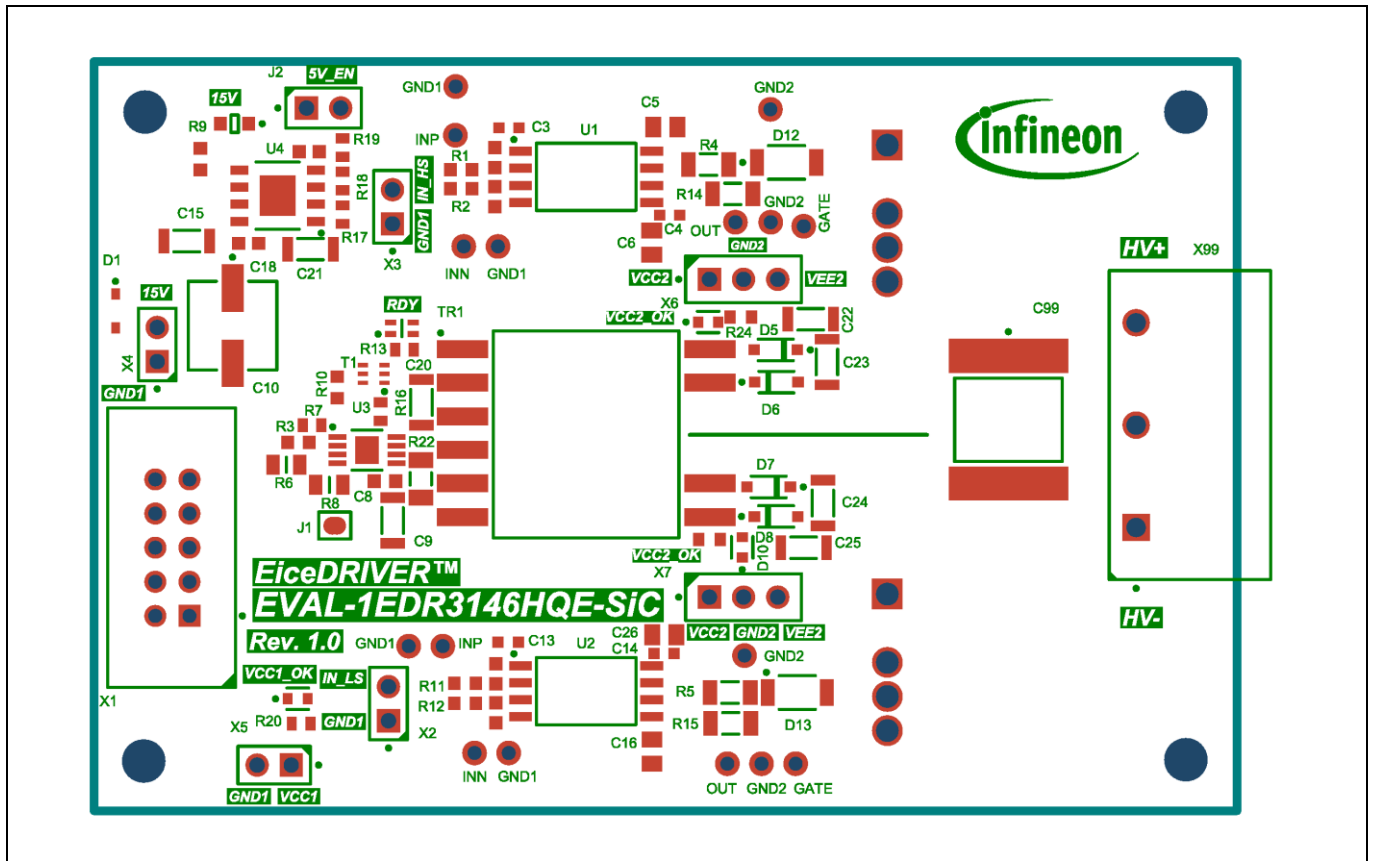

Figure 9 PCB top side

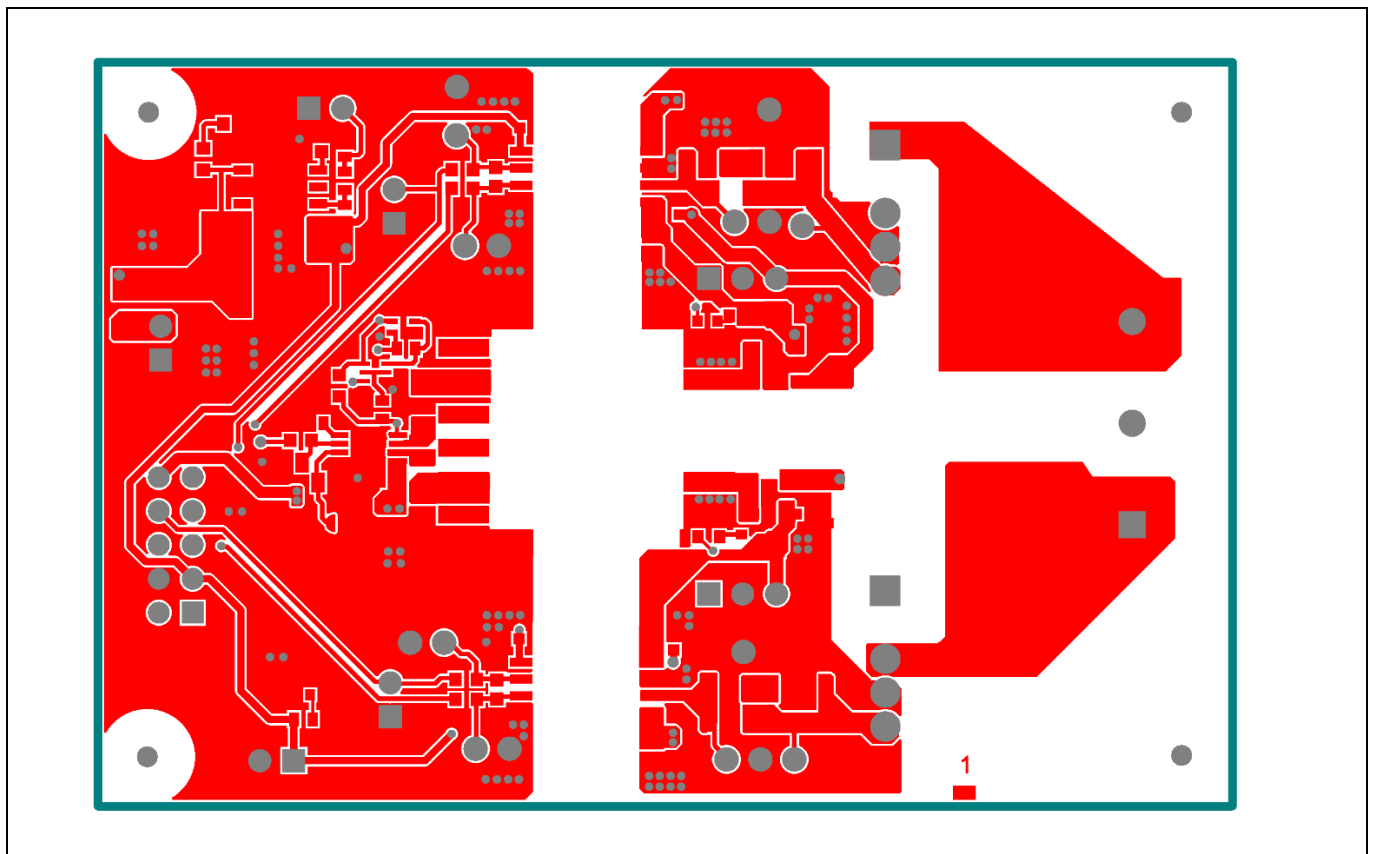

Figure 10 PCB top copper layer

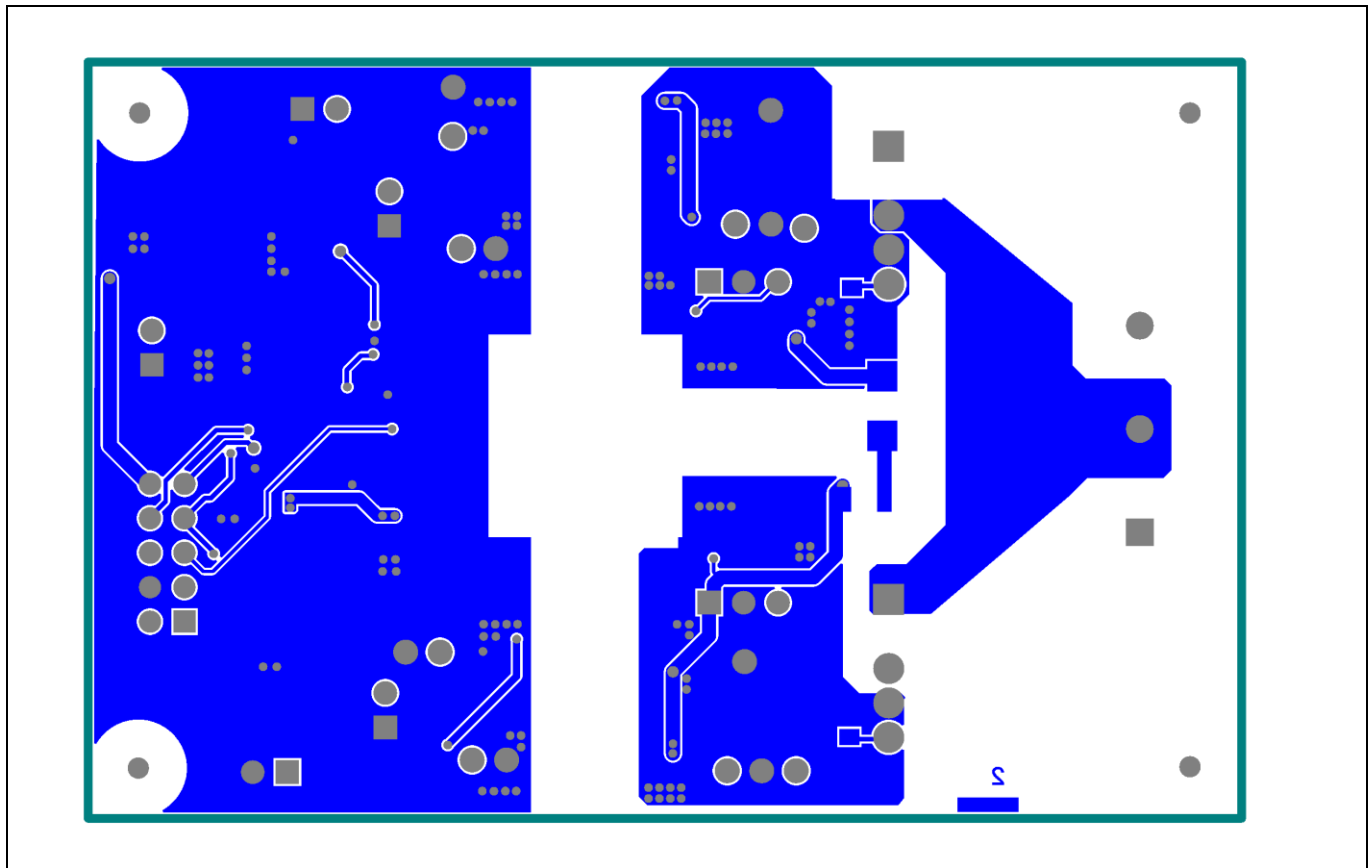

Figure 11 PCB bottom copper layer

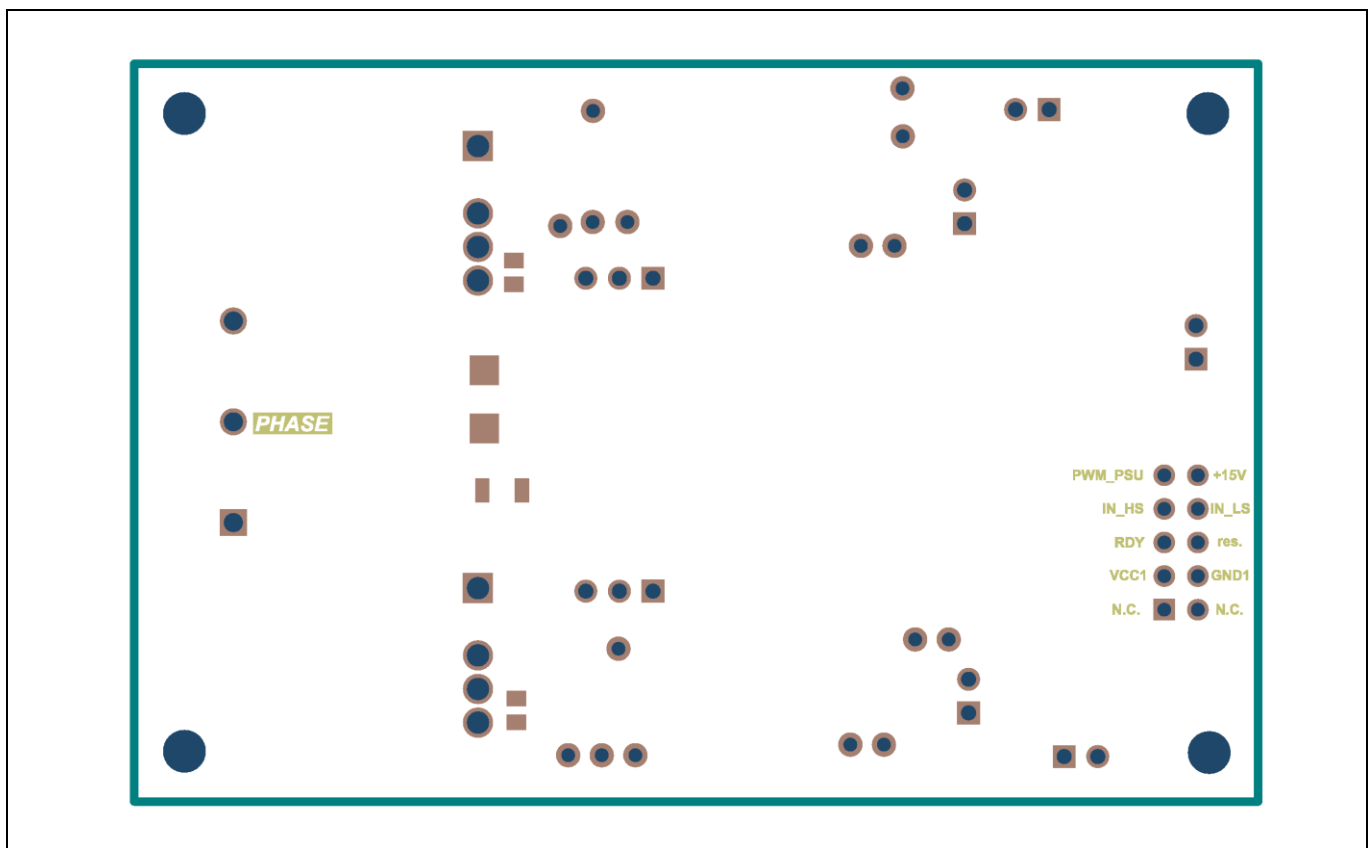

Figure 12 PCB bottom side

3.3 Bill of material

The complete bill of material is available on the download section of the evaluation board homepage.

Table 4 Bill of materials

Designator	Quantity	Description	Manufacturer	Manufacturer P/N
C3, C4, C13, C14	4	100nF	Würth Elektronik	885012206095
C5, C6, C16, C26	4	4.7uF	TDK Corporation	C2012X7R1H475K125AC
C8	1	100nF	AVX	06035C104K4Z2A
C9, C15, C20, C21, C22, C23, C24, C25	8	10uF	TDK Corporation, Würth Elektronik	C3216X7R1H106K160AC, 885012208069
C10	1	100uF	Würth Elektronik	865090445008
C18	1	1uF	Würth Elektronik	885012106022
C99	1	250nF	TDK Corporation	B58031I9254M062
D1	1	Medium Power AF Schottky Diode	Infineon Technologies	BAS3010B-03W
D2	1	Green	Würth Elektronik	150080VS75000
D3, D10, D11	3	Green	Kingbright	APHD1608LCGCK
D4	1	Multiple Color	Kingbright	KPTB-1612LVSURKCGKC
D5, D6, D7, D8	4	PMEG4010CEH,115	Nexperia	PMEG4010CEH,115
D12, D13	2	PMEG3050EP	Nexperia	PMEG3050EP
J1	1	Solder Jumper 2 Pins	Infineon Technologies	Solder Jumper 2 Pins
J2	1	61300211121	Würth Elektronik	61300211121
MP1, MP2, MP3, MP4	4	05.30.315	ETTINGER	05.30.315
MP5, MP6, MP7, MP8	4	D00688	Duratool	D00688
Q3, Q4	2	CoolSiC™ 1200 V 60 mohm SiC Trench MOSFET	Infineon Technologies	AIMZH120R060M1T
R1, R2, R3, R11, R12	5	0R	Bourns	CR0603-J-000ELF
R4, R5, R14, R15	4	3.3R	Vishay	CRCW12063R30FK
R6	1	1.07k	Vishay	CRCW08051K07FK
R7	1	47.5k	Vishay	CRCW060347K5FK
R8	1	590R	Vishay	CRCW0805590RFK
R9	1	2.2k	Vishay	TNPW06032K20BE
R10	1	10k	ROHM Semiconductors	MCR03EZPFX1002
R13, R20	2	620R	Vishay	CRCW0603620RFK
R16	1	2.2k	Vishay	CRCW06032K20FK
R17	1	33k	Vishay	CRCW060333K0FK
R18	1	11k	Vishay	CRCW060311K0FK
R19	1	8.2k	Vishay	CRCW06038K20FK
R22	1	330mR	Bourns	CRM1206-FX-R330 E LF
R23, R24	2	10k	Yageo	RC0603FR-0710KL
T1	1	Complementary power MOSFETs	Infineon Technologies	BSD235C
TR1	1	750319377	Würth Elektronik	750319377 R00
U1, U2	2	EiceDRIVER™ single channel galvanically isolated driver with secondary ground	Infineon Technologies	1EDR3146HQE
U3	1	Full bridge transformer driver	Infineon Technologies	2EP130R
U4	1	OPTIREG™ low dropout voltage regulator	Infineon Technologies	TLS205B0EJV
X1	1	T821110A1S100CEU	Amphenol	T821110A1S100CEU
X2, X3, X4, X5	4	HTSW-102-07-G-S	Samtec	HTSW-102-07-G-S
X6, X7	2	HTSW-103-07-G-S	Samtec	HTSW-103-07-G-S
X99	1	1766246	Phoenix Contact	1766246
X100	1	1767012	Phoenix Contact	1767012

3.4 Connector details

General information about the connectors of the Eval-1EDR3146HQE-SiC evaluation board is provided in this section.

Table 5 shows the connection of the high-voltage connector X99.

Table 5 High-voltage connectors

Connector / Pin	Symbol	Function
X99 (1)	HV-	DC-link ground connection
X99 (2)	PHASE	Half-bridge midpoint connection
X99 (3)	HV+	DC-link high-side connection

Table 6 shows the connections of the low voltage, input side connectors. This includes all the connectors, X1, X2, X3, X4, X5 and X6.

Table 6 Input side connectors pinout

PIN	Symbol	Function
X1 (1)	N.C.	Not connected
X1 (2)	N.C.	Not connected
X1 (3)	VCC1	Supply voltage for the input side of the gate drivers
X1 (4)	GND1	Ground for the input side of the board
X1 (5)	RDY	RDY state of isolated power supply. Active low signal
X1 (6)	.res	Not used
X1 (7)	IN_HS	Noninverting input for the high-side gate driver
X1 (8)	IN_LS	Noninverting input for the low-side gate driver
X1 (9)	PWM_PSU	External PWM signal for bypass mode of isolated power supply
X1 (10)	+15V	Supply voltage for the isolated power supply. Not reverse polarity protected
X2 (1)	GND1	Ground for the input side of the board
X2 (2)	IN_LS	Noninverting input for the low-side gate driver
X3 (1)	GND1	Ground for the input side of the board
X3 (2)	IN_HS	Noninverting input for the high-side gate driver
X4 (1)	GND1	Ground for the input side of the board
X4 (2)	15V	Reverse polarity protected, supply voltage for the isolated power supply
X5 (1)	VCC1	Supply voltage for the input side of the gate drivers
X5 (2)	GND1	Ground for the input side of the board

Table 7 shows the connection of the low-side supply connectors X7. This is used to supply the low-side gate drive secondary side. If the on-board isolated power supply board is not used, VCC2, GND2, and VEE2 voltage can be supplied here by means of an isolated power supply that allows floating operation of the gate driver as per application.

Table 7 Low-side gate driver IC -isolated secondary power supply

PIN	Symbol	Function
X7 (1)	VCC2	Low-side gate driver positive output supply connection
X7 (2)	GND2	Low-side gate driver supply ground reference connection
X7 (3)	VEE2	Low-side gate driver negative output supply connection

Table 8 shows the connection of the high-side supply connectors X6. This is used to supply the high-side gate drive secondary side. If the on-board isolated power supply board is not used, VCC2, GND2, and VEE2 voltage can be supplied here by means of an isolated power supply that allows floating operation of the gate driver as per application.

Table 8 High-side gate driver IC -isolated secondary power supply

PIN	Symbol	Function
X6 (1)	VCC2	High-side gate driver positive output supply connection
X6 (2)	GND2	High-side gate driver supply ground reference connection
X6 (3)	VEE2	High-side gate driver negative output supply connection

3.5 Test points

The test points used on the board are summarized in the table below.

Table 9 Test points

Test point	Symbol	Signal measured	Ground reference for test point
TP1	INP	High-side non-inverting input	GND1
TP2	INN	High-side inverting input	GND1
TP3	GND1	Input side ground	-
TP4	GND1	Input side ground	-
TP5	OUT	High-side output	GND2
TP6	GATE	High-side gate voltage	GND2
TP7	GND2	High-side ground reference	-
TP8	GND2	High-side ground reference	-
TP11	INP	Low-side non-inverting input	GND1
TP12	INN	Low-side inverting input	GND1
TP13	GND1	Input side ground	-
TP14	GND1	Input side ground	-
TP15	OUT	Low-side output	GND2
TP16	GATE	Low-side gate voltage	GND2
TP17	GND2	Low-side ground reference	-
TP18	GND2	Low-side ground reference	-

4 References and appendices

4.1 References

- [1] [Datasheet of Infineon EiceDRIVER™ 1EDR3146HQE](#)
- [2] [Datasheet of EiceDRIVER™ Power 2EP130R](#)
- [3] [User guide of EVAL-2EP130R-PR-SiC](#)
- [4] [Datasheet of Infineon AIMZH120R060M1T](#)

4.2 Ordering information

Base Part Number	Package	Standard Pack		Orderable Part Number
		Form	Quantity	
Eval-1EDR3146HQE-SiC	-	Boxed	1	EVAL1EDR3146HQUESICTOBO1
1EDR3144HQE	PG-LDSO-8	TAPE & REEL	1000	1EDR3144HQEXUMA1
1EDR3146HQE	PG-LDSO-8	TAPE & REEL	1000	1EDR3146HQEXUMA1
2EP130R	PG-TSSOP-8	TAPE & REEL	1000	2EP130RXTMA1
AIMZH120R060M1T	PG-TO247-7	Tube	240	AIMZH120R060M1TXKSA1

Revision history

Document version	Date	Description of changes
V1.0	2025-04-15	Initial release

Trademarks

All referenced product or service names and trademarks are the property of their respective owners.

Edition 2025-04-15**Published by****Infineon Technologies AG****81726 Munich, Germany****© 2025 Infineon Technologies AG.****All Rights Reserved.****Do you have a question about this document?****Email: erratum@infineon.com****Document reference****UG-2025-10****WARNINGS**

Due to technical requirements products may contain dangerous substances. For information on the types in question please contact your nearest Infineon Technologies office.

Except as otherwise explicitly approved by Infineon Technologies in a written document signed by authorized representatives of Infineon Technologies, Infineon Technologies' products may not be used in any applications where a failure of the product or any consequences of the use thereof can reasonably be expected to result in personal injury.