

TLE 4801/03 Evaluation board user guide

About this document

Scope and purpose

This document describes the evaluation board for the TLE4801/03 inductive torque and angle sensor. The purpose of this manual is to describe the software installation process and how to use the TLE4801/03 inductive torque and angle sensor Evaluation board. The sensor board coil design is designed to allow the torque and angle functionality but also the absolute angle measurement.

Intended audience

This document is intended for anyone who wants to use the TLE4801/03 inductive torque and angle sensor or inductive linear position sensor demonstrator kit.

Evaluation Board

This board is to be used during the design-in process for evaluating and measuring characteristic curves, and for checking datasheet specifications.

Note: PCB and auxiliary circuits are NOT optimized for final customer design.

TLE 4801/03 Evaluation board user guide

Important notice

Important notice

“Evaluation Boards and Reference Boards” shall mean products embedded on a printed circuit board (PCB) for demonstration and/or evaluation purposes, which include, without limitation, demonstration, reference and evaluation boards, kits and design (collectively referred to as “Reference Board”).

Environmental conditions have been considered in the design of the Evaluation Boards and Reference Boards provided by Infineon Technologies. The design of the Evaluation Boards and Reference Boards has been tested by Infineon Technologies only as described in this document. The design is not qualified in terms of safety requirements, manufacturing and operation over the entire operating temperature range or lifetime.

The Evaluation Boards and Reference Boards provided by Infineon Technologies are subject to functional testing only under typical load conditions. Evaluation Boards and Reference Boards are not subject to the same procedures as regular products regarding returned material analysis (RMA), process change notification (PCN) and product discontinuation (PD).

Evaluation Boards and Reference Boards are not commercialized products, and are solely intended for evaluation and testing purposes. In particular, they shall not be used for reliability testing or production. The Evaluation Boards and Reference Boards may therefore not comply with CE or similar standards (including but not limited to the EMC Directive 2004/EC/108 and the EMC Act) and may not fulfill other requirements of the country in which they are operated by the customer. The customer shall ensure that all Evaluation Boards and Reference Boards will be handled in a way which is compliant with the relevant requirements and standards of the country in which they are operated.

The Evaluation Boards and Reference Boards as well as the information provided in this document are addressed only to qualified and skilled technical staff, for laboratory usage, and shall be used and managed according to the terms and conditions set forth in this document and in other related documentation supplied with the respective Evaluation Board or Reference Board.

It is the responsibility of the customer’s technical departments to evaluate the suitability of the Evaluation Boards and Reference Boards for the intended application, and to evaluate the completeness and correctness of the information provided in this document with respect to such application.

The customer is obliged to ensure that the use of the Evaluation Boards and Reference Boards does not cause any harm to persons or third party property.

The Evaluation Boards and Reference Boards and any information in this document is provided "as is" and Infineon Technologies disclaims any warranties, express or implied, including but not limited to warranties of non-infringement of third party rights and implied warranties of fitness for any purpose, or for merchantability.

Infineon Technologies shall not be responsible for any damages resulting from the use of the Evaluation Boards and Reference Boards and/or from any information provided in this document. The customer is obliged to defend, indemnify and hold Infineon Technologies harmless from and against any claims or damages arising out of or resulting from any use thereof.

Infineon Technologies reserves the right to modify this document and/or any information provided herein at any time without further notice.

TLE 4801/03 Evaluation board user guide

Table of contents

Table of contents

About this document.....	1
Important notice	2
Table of contents.....	3
1 Inductive sensor demonstrator boards	4
1.1 Rotary position sensor	4
1.1.1 Mechanical setup	4
1.1.2 Output modes	5
1.1.2.1 Torque mode.....	5
1.1.2.2 Absolute angle mode	7
1.2 Linear position sensor.....	8
1.2.1 Mechanical setup	8
1.2.2 Output modes	10
2 Programming interface MSS Readout Tool.....	11
3 Evaluation software and system setup	12
3.1 Getting started.....	12
3.2 Hardware connection.....	13
3.3 Readout mode	14
3.3.1 The readout view – logging window.....	15
3.3.2 The readout view – error indication window	16
3.4 SICI Readout mode.....	17
3.4.1 SICI Readout view – Angle 1/2 & Torque	19
3.4.2 SICI Readout view – Vector Length.....	20
3.4.3 SICI Readout view – ADC Raw	21
3.4.4 SICI Readout view – ADC Compensated	22
3.4.5 SICI Readout view – Coil Configuration Window	23
3.5 Memory Map View	24
3.5.1 CMTTP memory map.....	24
3.5.2 Internal registers	26
Revision history.....	27
Disclaim.....	28

TLE 4801/03 Evaluation board user guide

Inductive sensor demonstrator boards

1 Inductive sensor demonstrator boards

Inductive position sensors offer high design flexibility for different position sensing applications. With the same sensor IC from the TLE4801/03 family angle, torque but also linear travel measurements can be realized with different sensing coil designs. Exemplary sensor reference designs are available using the TLE4801/03 product family.

1.1 Rotary position sensor

The torque and angle demonstrator is designed to demonstrate rotary sensing applications. The TLE4801 iTAS Evaluation board consists of:

- A coil PCB with the TLE4801 assembled,
- Two target PCBs,
- Mechanical components.

1.1.1 Mechanical setup

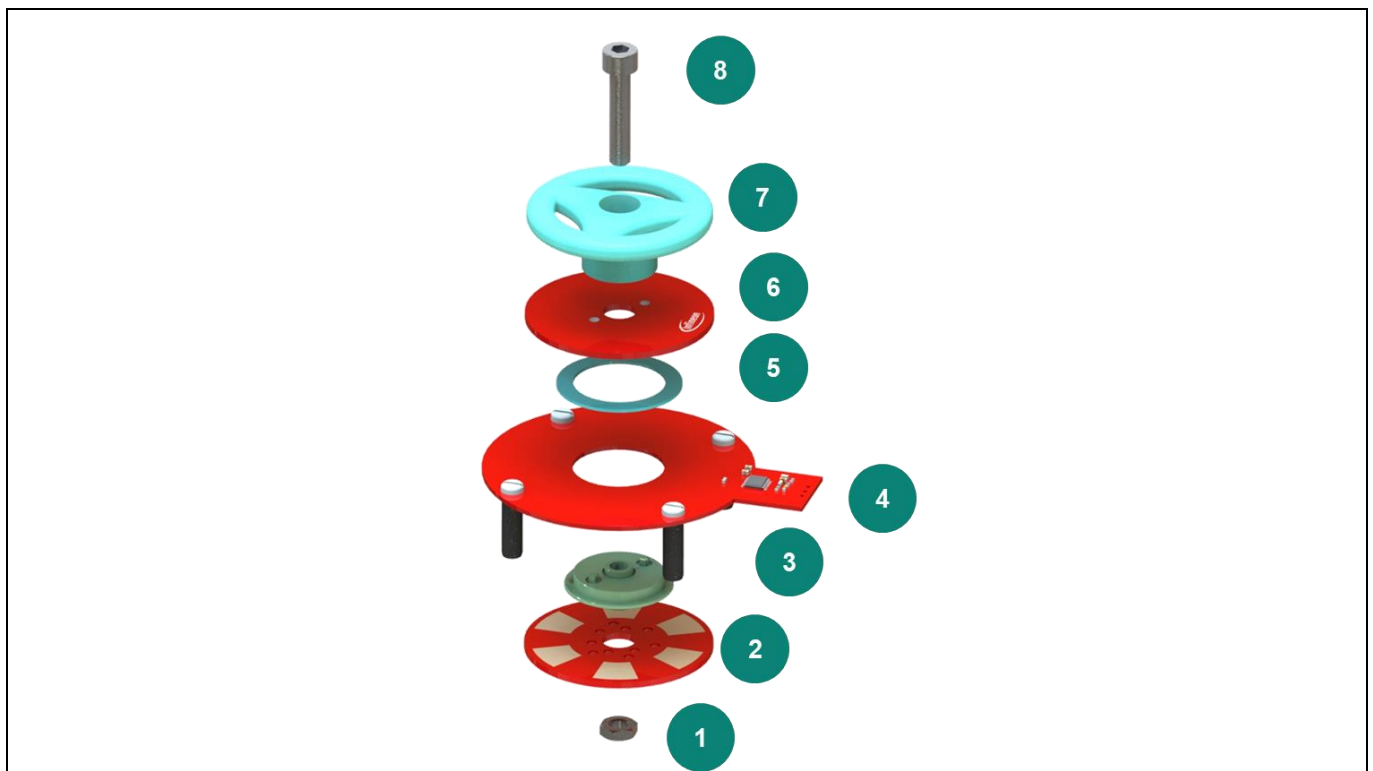

Figure 1 Explosion view of the TLE4801 Eval Kit

TLE 4801/03 Evaluation board user guide

Inductive sensor demonstrator boards

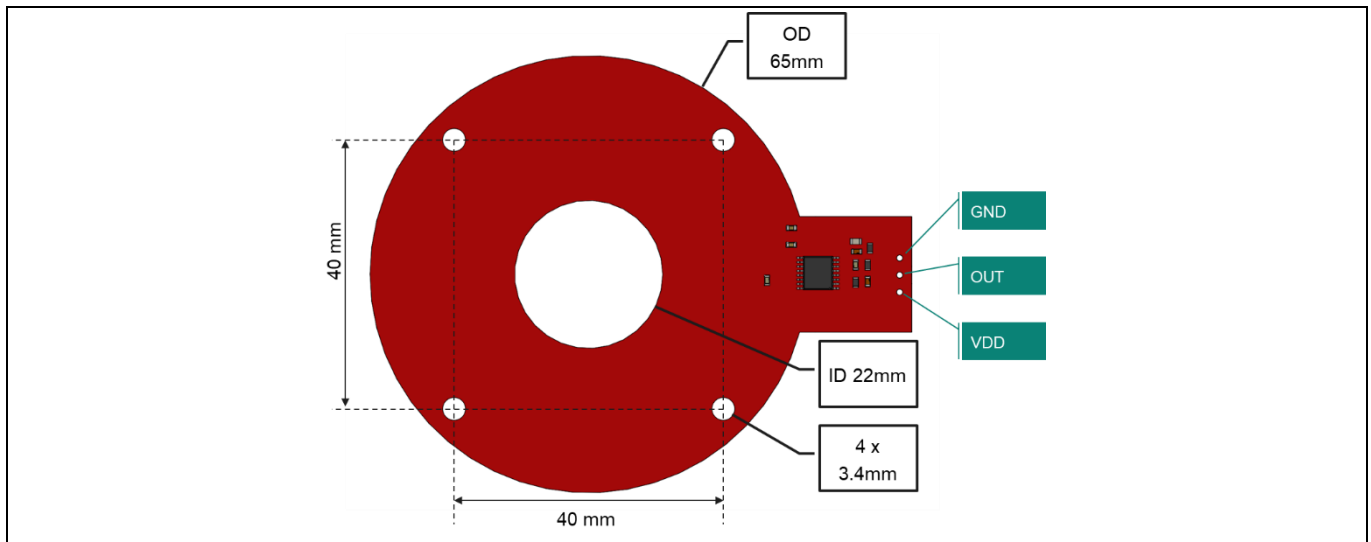

Figure 2 Coil PCB dimensions and pinout

With the through holes on the coil PCB, the sensor can be assembled to a test bench. 4xM3 screws can be used for fixation.

1.1.2 Output modes

The TLE4801/03 product family offers different output modes. The torque and angle demonstrator is designed with a period count of 5 and 6 periods over one mechanical rotation. The concept demonstrates 2 operation modes,

- Torque operation mode
- Absolute position operation mode

In angle mode, the mechanical angle is constructed from the partial angles for applications which need high resolution. In torque mode the difference angle is computed from the partial angles, typically this is used in torque sensors in electric power steering (EPS).

1.1.2.1 Torque mode

To operate the demonstrator in torque mode, the number of target wings needs to be set correctly. With the current design of 5 and 6 periods, the number of wings at angle1 needs to be set to 5 and the angle2 to 6. For details on the registers, please refer to the relevant user manual of the TLE4801/03 family.

To demonstrate the torque functionality the torque and angle demonstrator board features 5 different locator positions on the bottom target. To set the difference angle between the top and bottom target, the bottom target needs to be lifted and put into another position. 5 equiangular positions are available from -5° to 5° .

TLE 4801/03 Evaluation board user guide

Inductive sensor demonstrator boards

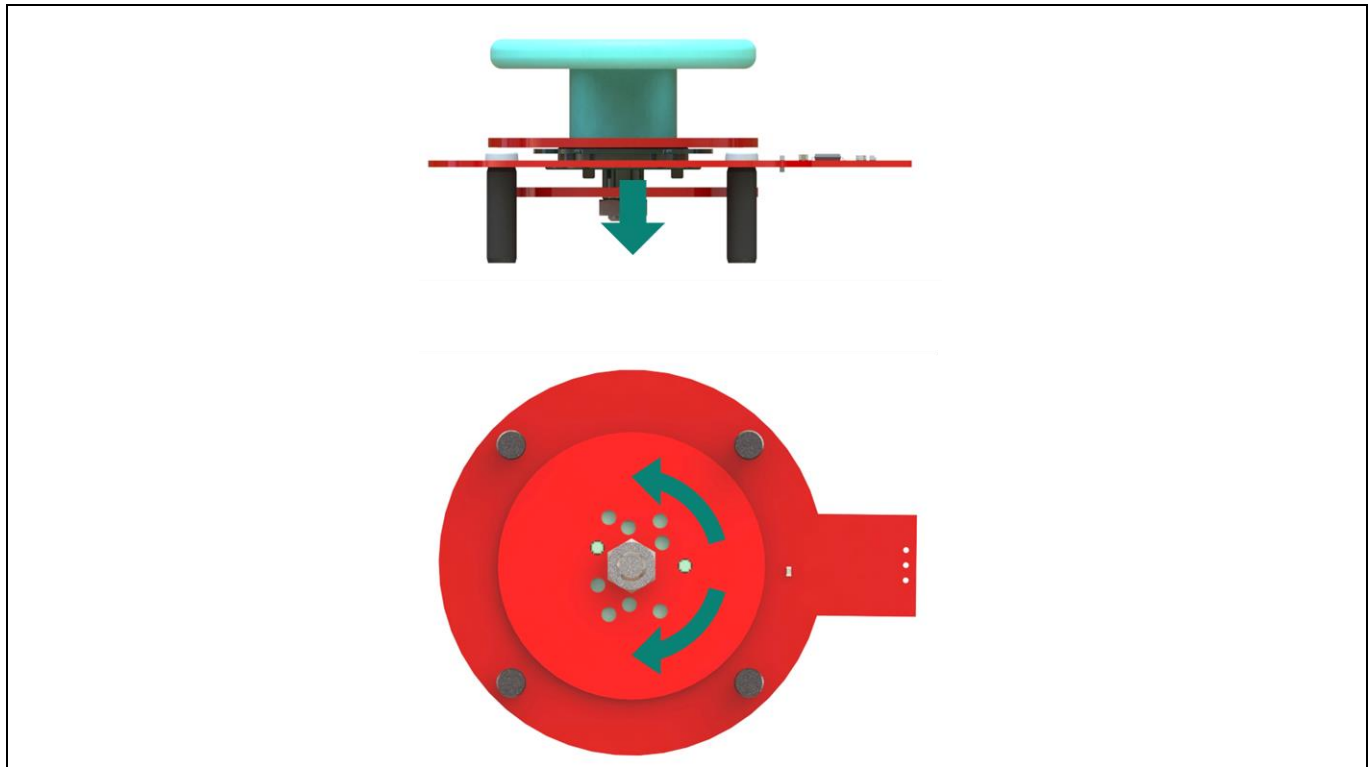

Figure 3 Bottom target offset angle adjustment

With this setting the nonius calculation done inside the TLE4801 generates the difference angle between the top and bottom target. Please note, that the output is dependent on the output protocol selected for the TLE4801. For details and the possible options, please refer to the respective datasheet.

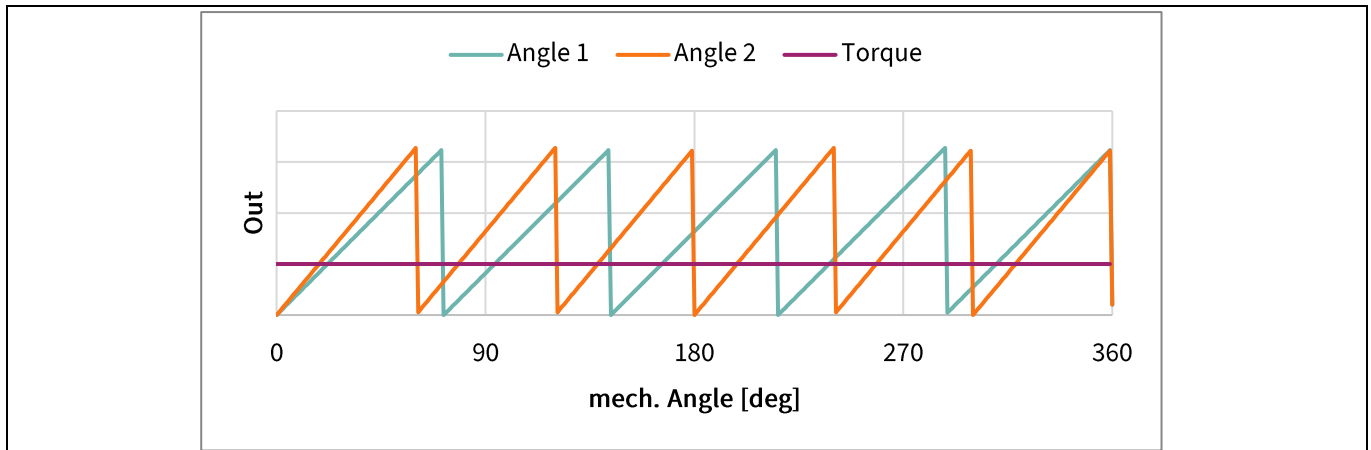

Figure 4 Ideal outputs in torque operation mode

TLE 4801/03 Evaluation board user guide

Inductive sensor demonstrator boards

1.1.2.2 Absolute angle mode

To operate the demonstrator in absolute position mode, the number of target wings needs to be set correctly. With the current design of 5 and 6 periods, the number of wings at angle1 and angle2 need to be both set to 1. For details on the registers, please refer to the relevant user manual of the TLE4801/03 family.

With this setting the nonius calculation done inside the TLE4801 generates the absolute mechanical position from the 2 individual partial angles. Please note, that the output is dependent on the output protocol selected for the TLE4801. For details and the possible options, please refer to the respective datasheet.

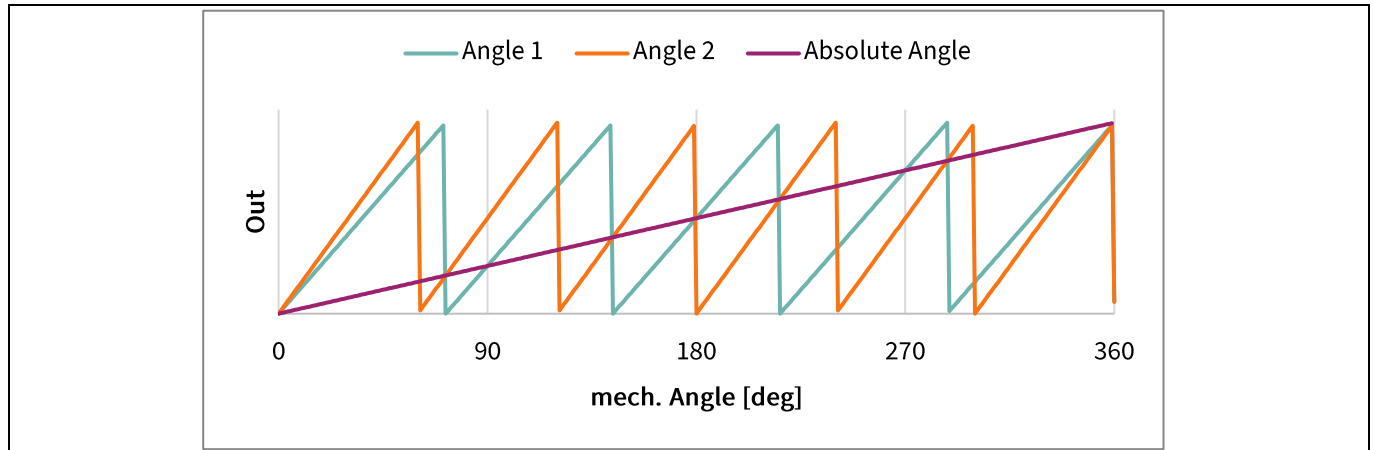

Figure 5 Ideal outputs in angle operation mode

TLE 4801/03 Evaluation board user guide

Inductive sensor demonstrator boards

1.2 Linear position sensor

The TLE4803 linear position sensors are available in 2 versions with 200mm and 300mm of measurement range. Both variants contain:

- A coil PCB with the TLE4803 assembled,
- One target PCB,
- Mechanical components.

1.2.1 Mechanical setup

Two versions of linear demonstrator are available with two different measurement ranges and receiving coil configurations. To demonstrate the potential in design flexibility the linear position sensors were designed with the following variants.

- The 200mm demo features an absolute track combined with a high-resolution track with 5 periods,
- The 300mm demo features a nonius concept with 4 respectively 5 periods over the uniqueness range.

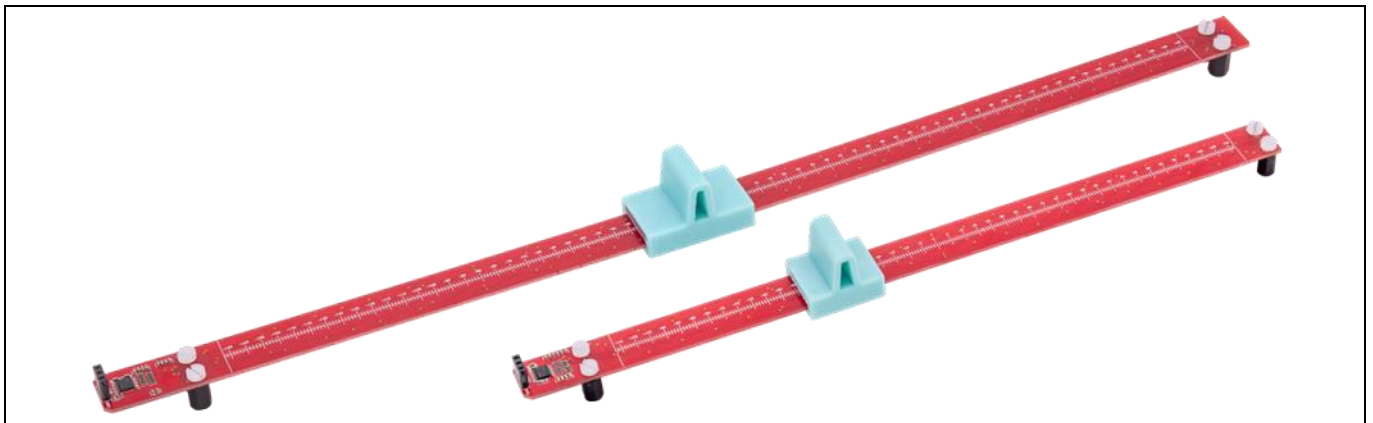

Figure 6 Inductive linear position sensor boards

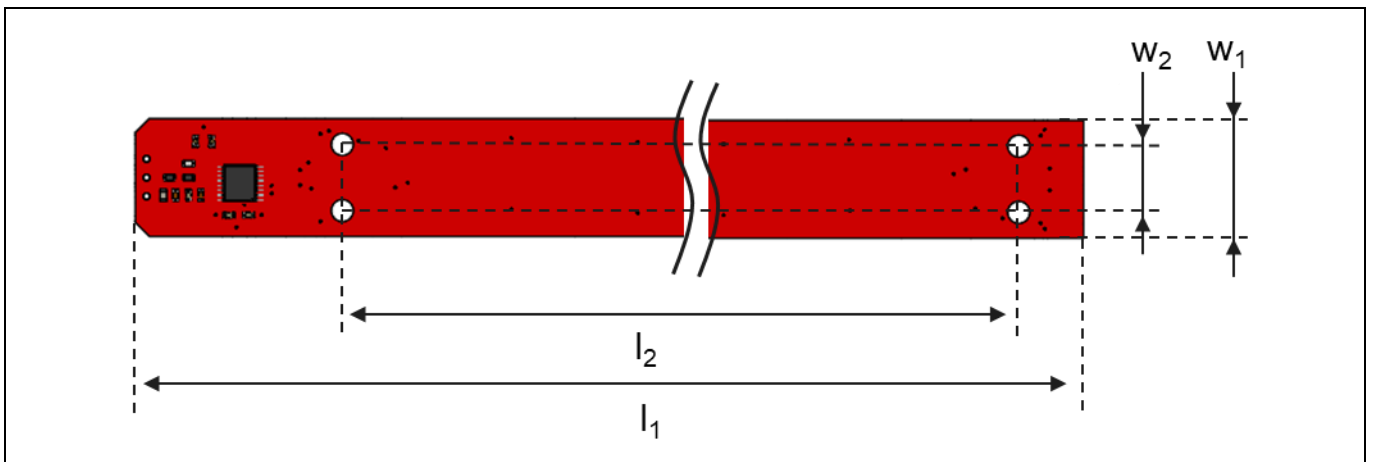

Figure 7 Coil PCB dimensions

TLE 4801/03 Evaluation board user guide

Inductive sensor demonstrator boards

Table 1 Coil PCB dimensions parameters

Parameter	200mm demo	300mm demo	Unit
l_1	270.5	391	mm
l_2	245	354	mm
w_1	16	16	mm
w_2	9	9	mm
\varnothing	3	3	mm

TLE 4801/03 Evaluation board user guide

Inductive sensor demonstrator boards

1.2.2 Output modes

The output modes for the 200 mm and 300 mm demonstrator board are different by means of the angle 1 and angle 2 information generated during measurement. The graph below shows the output information generated over the 200 mm measurement range with the demonstrator board. Angle 1 gives the full travel range with one period, angle 2 gives a sawtooth signal with 5 periods over the travel range. This configuration allows the direct true-power-on position detection combined with a high resolution of the 5 periods.

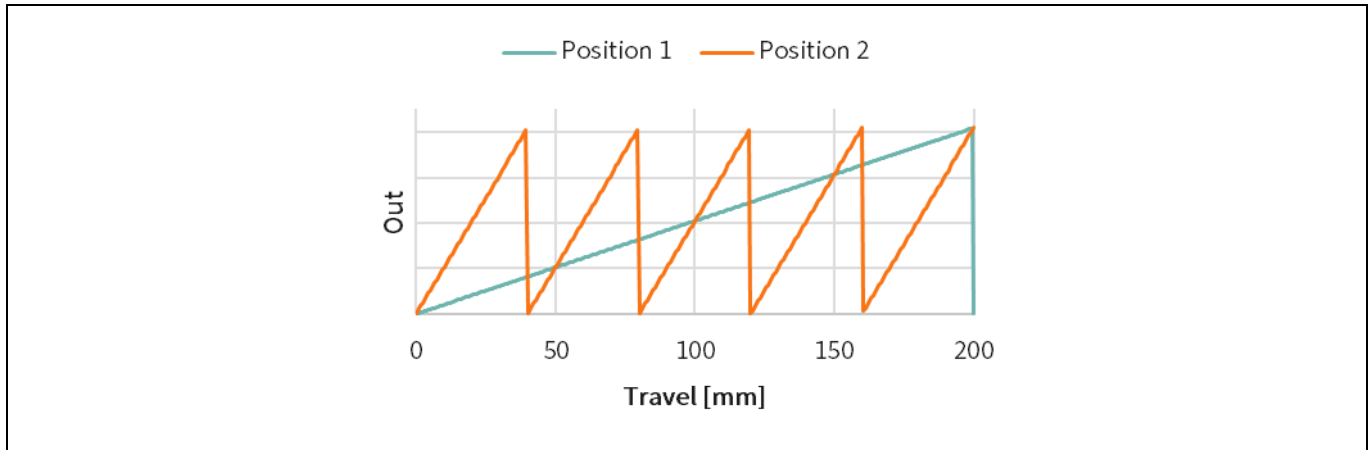

Figure 8 200 mm linear demonstrator output

The 300 mm demonstrator board generates 4 periods on angle 1 and 5 periods on angle 2 along the 300 mm measurement range. With this configuration the true-power-on position detection can be obtained from both outputs, exemplary through a nonius calculation. The figure below shows the exemplary output generated.

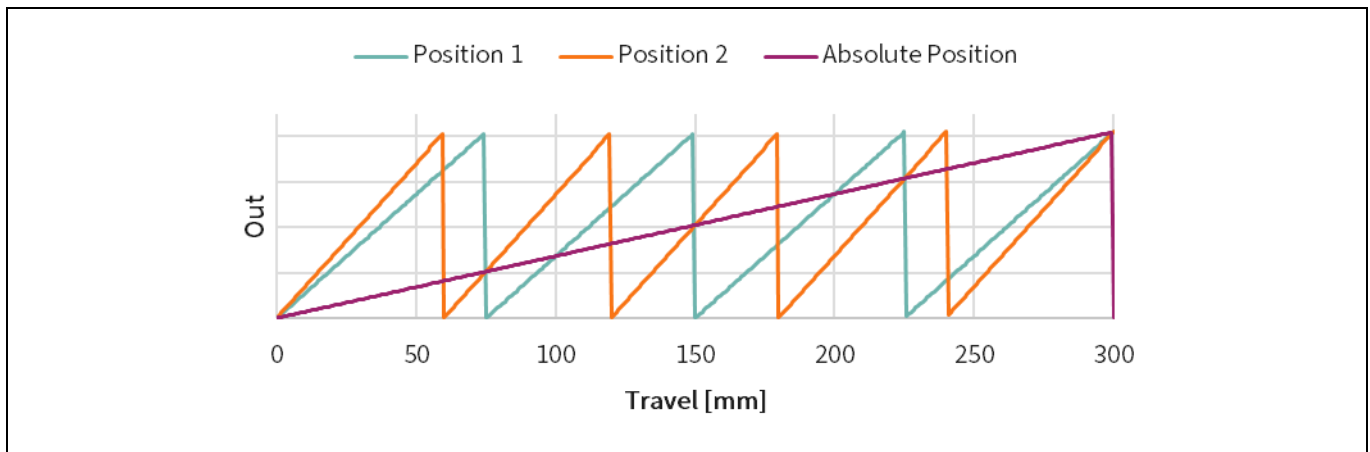

Figure 9 300 mm linear demonstrator output

TLE 4801/03 Evaluation board user guide

Programming interface MSS Readout Tool

2 Programming interface MSS Readout Tool

The inductive sensor demonstrators can be programmed with the MSS Readout tool. The programmer is based POSIF board (position sensor interface board) - featuring an XMC4700 microcontroller and the SSRT (Speed Sensor Readout Tool) frontend board

The evaluation board package consists of the following components:

- Position Sensors Interface board.
- Speed Sensors Readout Tool board. Both boards are already stacked together via headers.
- 24V power supply (and power plug adapters when available at supplier)
- Micro USB cable

For more details on the MSS READOUT TOOL, please refer to the XENSIV™ Speed Sensors Readout Tool User guide

TLE 4801/03 Evaluation board user guide

Evaluation software and system setup

3 Evaluation software and system setup

3.1 Getting started

Before working with the demonstrator, the software needs to be downloaded at:

<https://softwaretools.infineon.com/tools/com.ifx.tb.tool.xensivtle480xangletorquesensorevaluationsoftware>

The following installation steps for the software need to be executed:

- Install the Evaluation board software by double clicking on the installer file
- Administrator rights are required for installing the software and the required dependencies
- User must accept the License Agreement to continue with the installation process
- Quick installation is preferred, but any option can be chosen
- Dependencies installation can be skipped by unchecking them in “Custom Installation” or simply by cancelling the corresponding dialog window when it is prompted
- After software installation is finished, dependencies installation is prompted
- If the required dependencies are already installed on the computer (.NET 4.8 or above and FTDI driver version 2.12.28 or above), installation can be cancelled/skipped
- When the installation finished successfully, the user can choose to run the software and to view the release notes
- A desktop icon is created automatically

Please be aware that in case the FTDI driver is installed for the first time on the computer, the POSIF board must be connected before starting the software.

TLE 4801/03 Evaluation board user guide

Evaluation software and system setup

3.2 Hardware connection

The demonstrator board and the MSS Readout Tool needs to be connected like below:

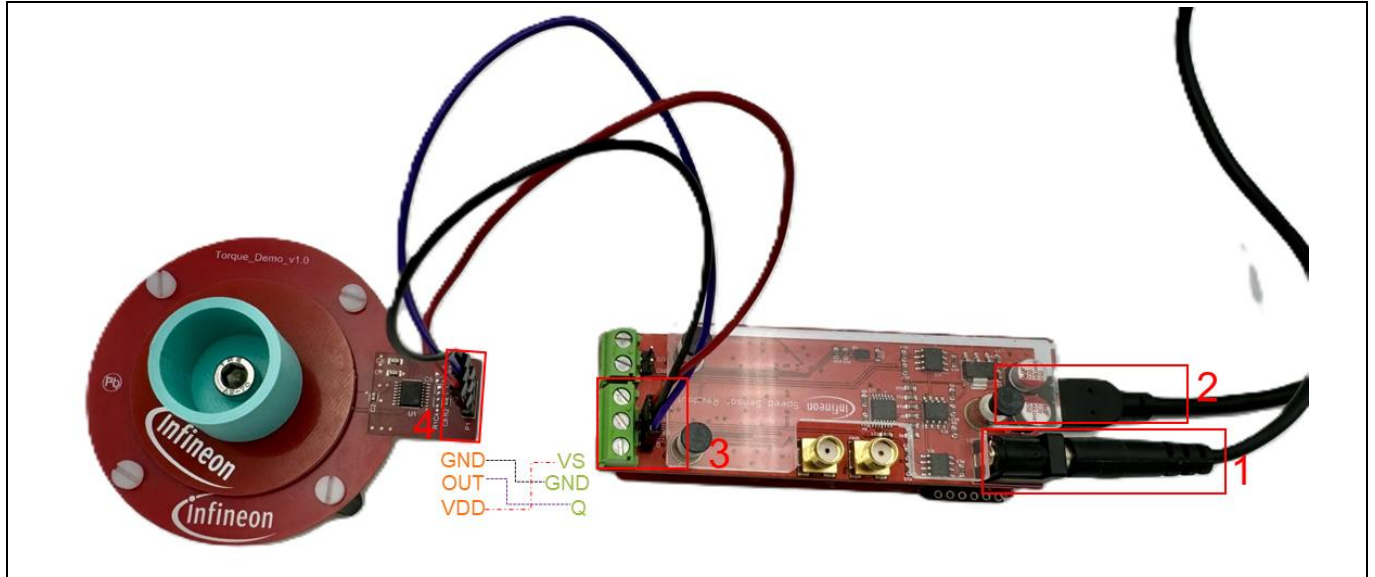

Figure 10 Connection of demonstrator board and MSS Readout Tool

Once correctly connected and started the software, the software will monitor all USB ports and check if any connected device matches the signature of the evaluation board. A new device will appear as “Port X”. By selecting the device, the software will connect and flash the correct firmware for the target microcontroller.

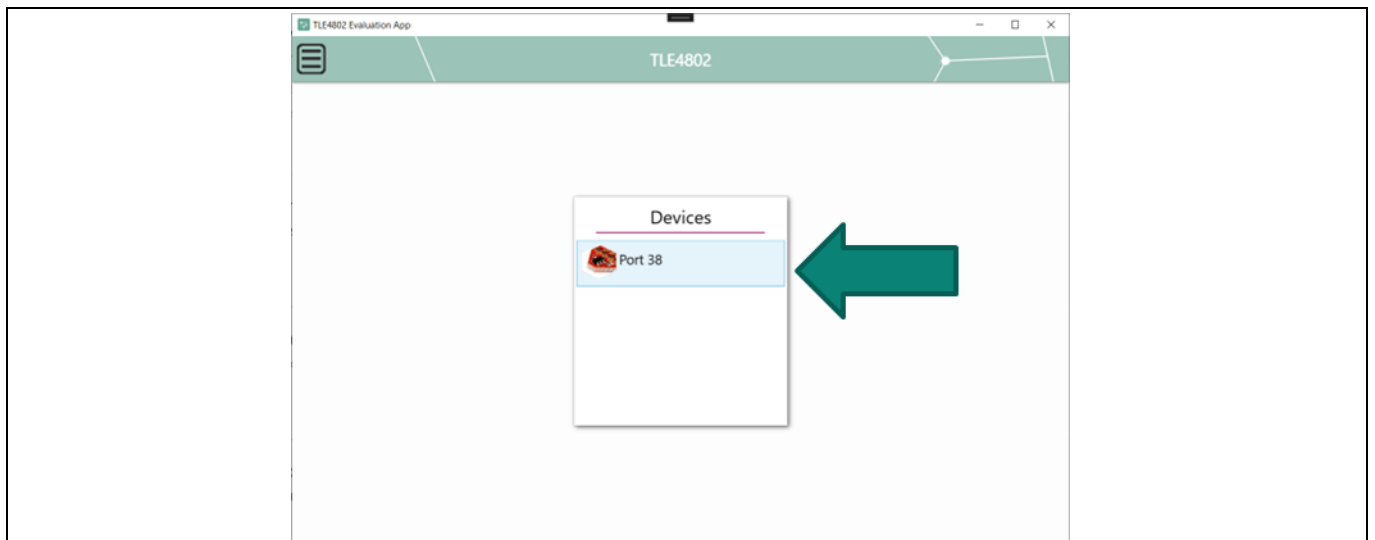

Figure 11 Device selection in the evaluation software

TLE 4801/03 Evaluation board user guide

Evaluation software and system setup

3.3 Readout mode

The user can now enter the readout mode through selecting the panel “Readout mode”.

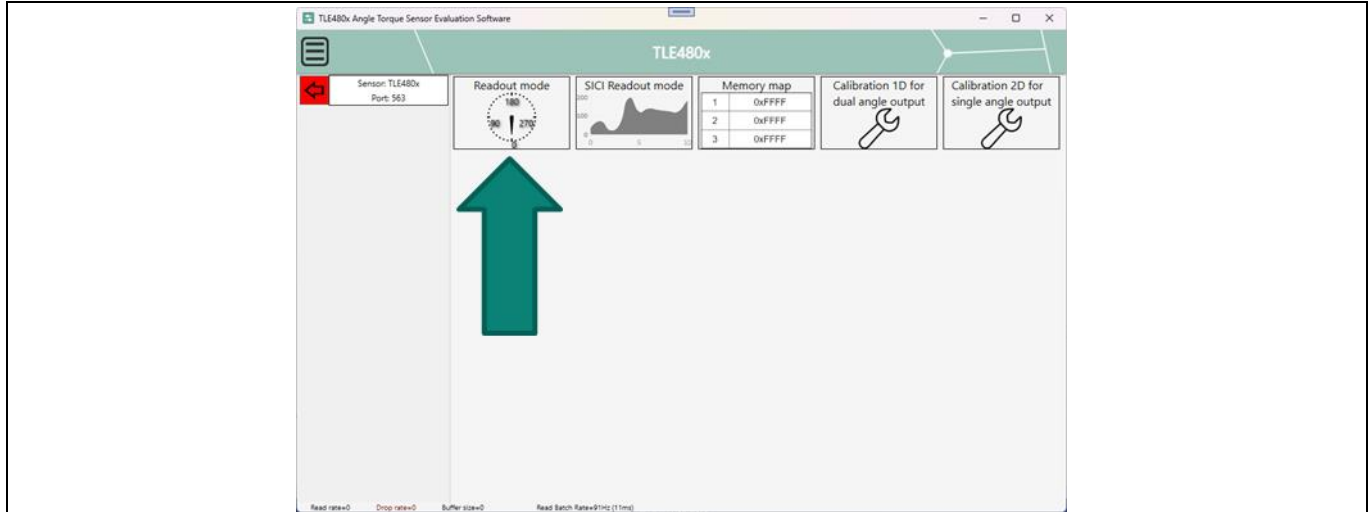

Figure 12 Selection of the readout mode

Readout mode panel plots on charts the sensor’s output. It has 3 charts:

- Angular Gauge for Angle 1 (and its projection in cartesian) (1)
- Angular Gauge for Angle 2 (and its projection in cartesian) (2)
- Cartesian chart for Torque (3)

The opened view contains inside other views and features:

- Acquisition settings (4)
- Chart settings (5)
- Logging (6)
- Error Indication (7)

TLE 4801/03 Evaluation board user guide

Evaluation software and system setup

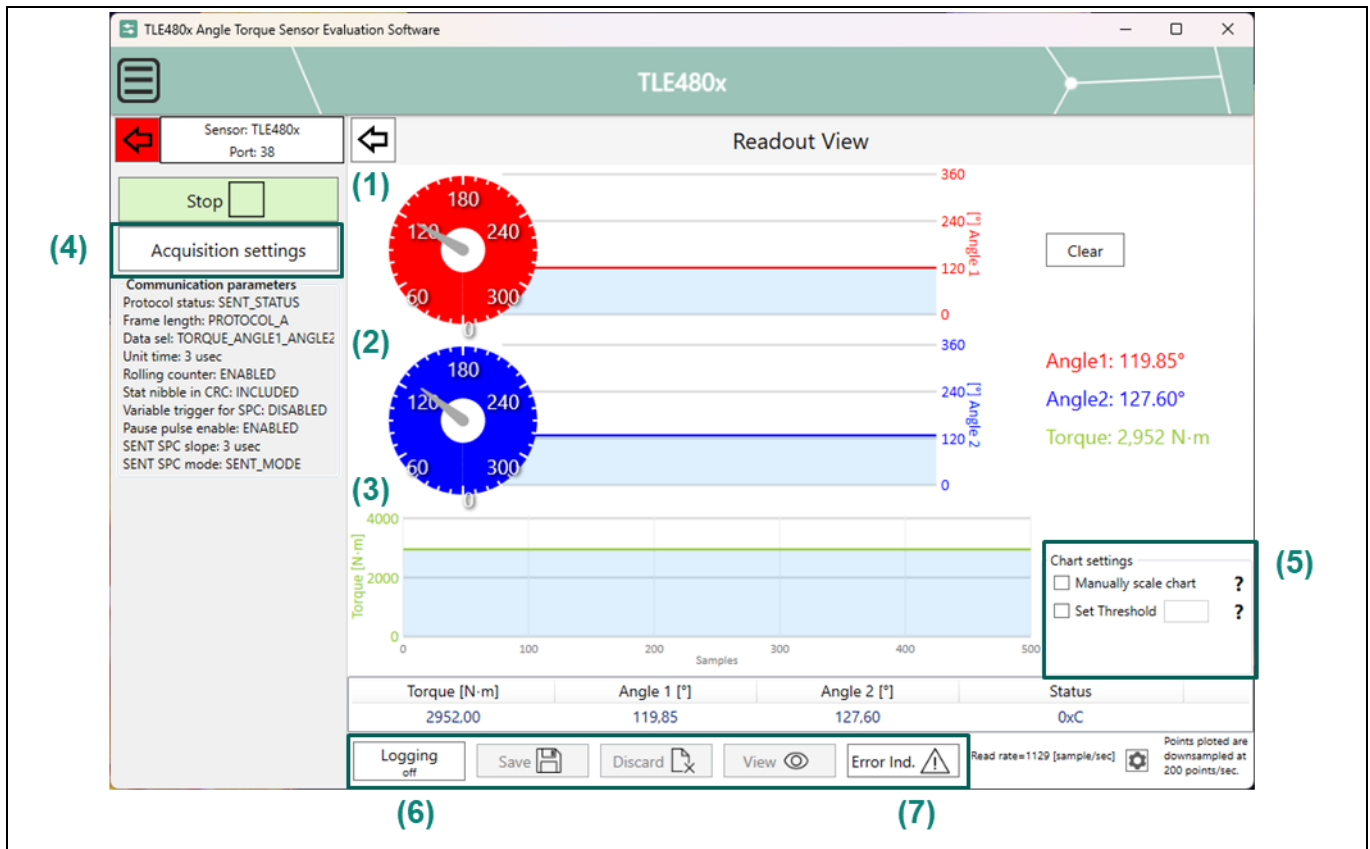

Figure 13 Readout mode panel

The readout view content is automatically configured based on the CMTP configuration, based on the data selection of the SPC/SENT protocol written in the CMTP. All received data can be logged in csv format. This contains raw and processed data, device status, CRC and any error indication captured on the communication pin during a SPC/SENT communication. Please refer to the datasheet and user manual for details.

3.3.1 The readout view – logging window

The readout view – logging window is a feature useful to view logged points, without needing to reconstruct a chart from the saved points in the csv file.

TLE 4801/03 Evaluation board user guide

Evaluation software and system setup

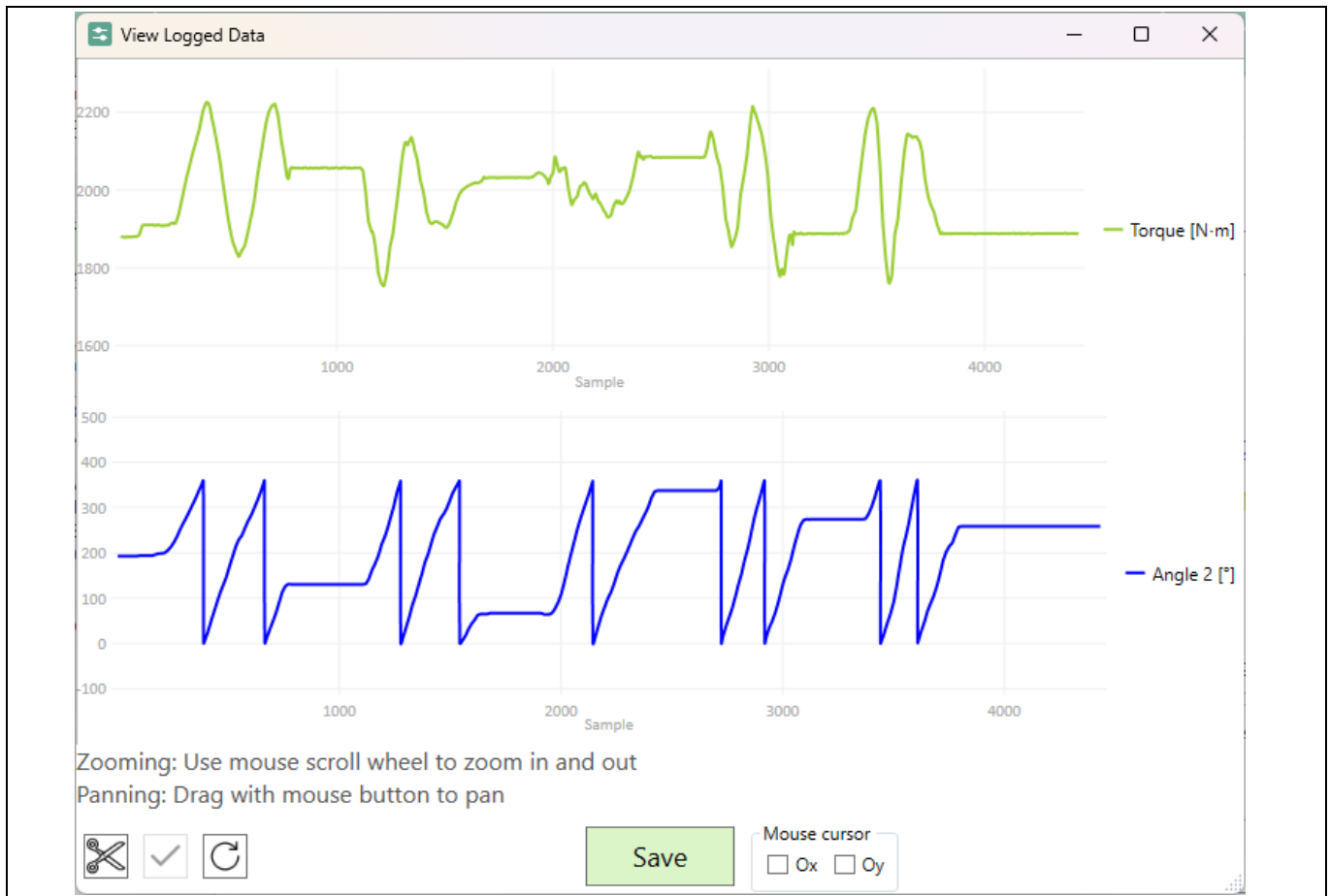

Figure 14 Readout view – logging window

3.3.2 The readout view – error indication window

The readout view – error indications window displays all the captured error indications in the SENT/SPC communication. The list is updated every second. The error indication is included in the default logging capabilities. The window is closed automatically when exiting the readout mode.

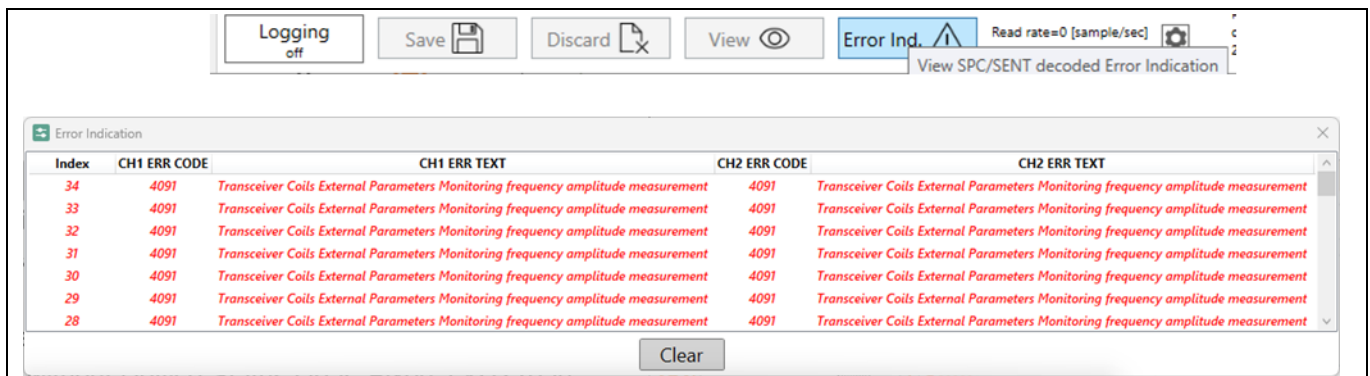

Figure 15 Readout view – error indication window

TLE 4801/03 Evaluation board user guide

Evaluation software and system setup

3.4 SICI Readout mode

After successful software startup, the user can now enter the SICI Readout mode through selecting the panel “SICI Readout mode”. Here the sensor can be programmed via SICI and the normal 5 V voltage level is applied. This way it is possible to fine tune values in the “READ_IN_REGISTERS” and to read via SICI the raw values or angular digital values through the working registers afterwards.

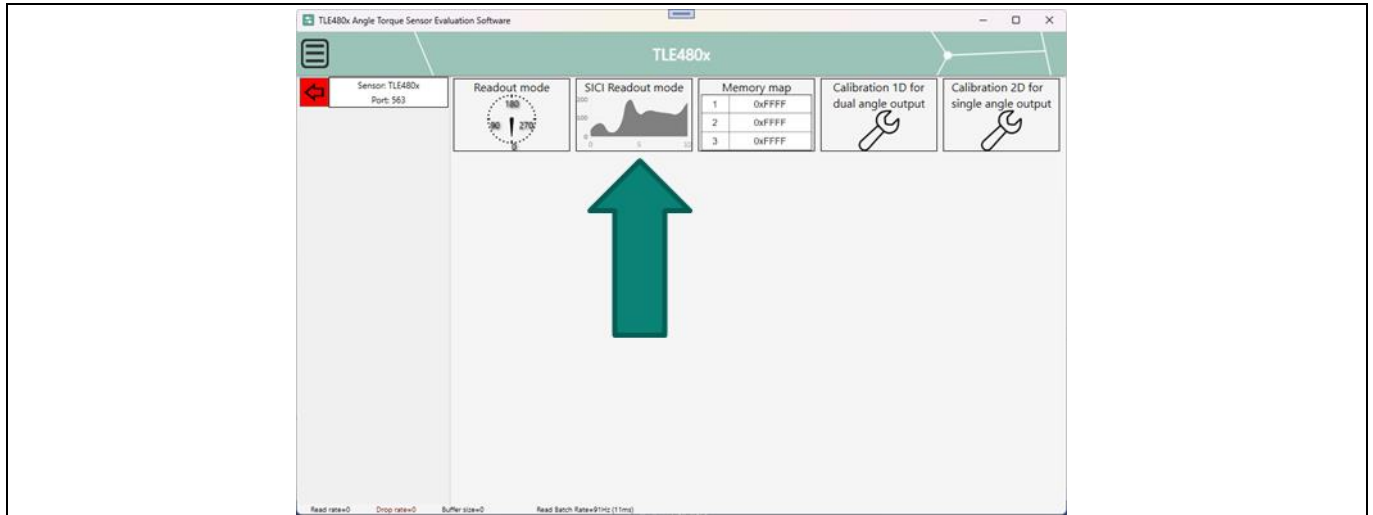

Figure 16 Selection of SICI Readout mode

SICI Readout mode displays, plots and logs the sensor’s registers content at a fixed 100 Hz sample frequency. It has 4 selectable views:

- Angle 1/2 & Torque (angle1/2_dsp_int_reg, torque_dsp_int_reg)
- Vector Length 1/2 & ADC Range 1/2 (vector_len_dsp_adc1/2_int_reg, osc_amp_reg)
- ADC1/2 Raw (adc1/2_x_reg, adc1/2_y_reg)
- ADC1/2 Compensated (x1/2_o_dsp_int_reg and y1/2_f_dsp_int_reg)

TLE 4801/03 Evaluation board user guide

Evaluation software and system setup

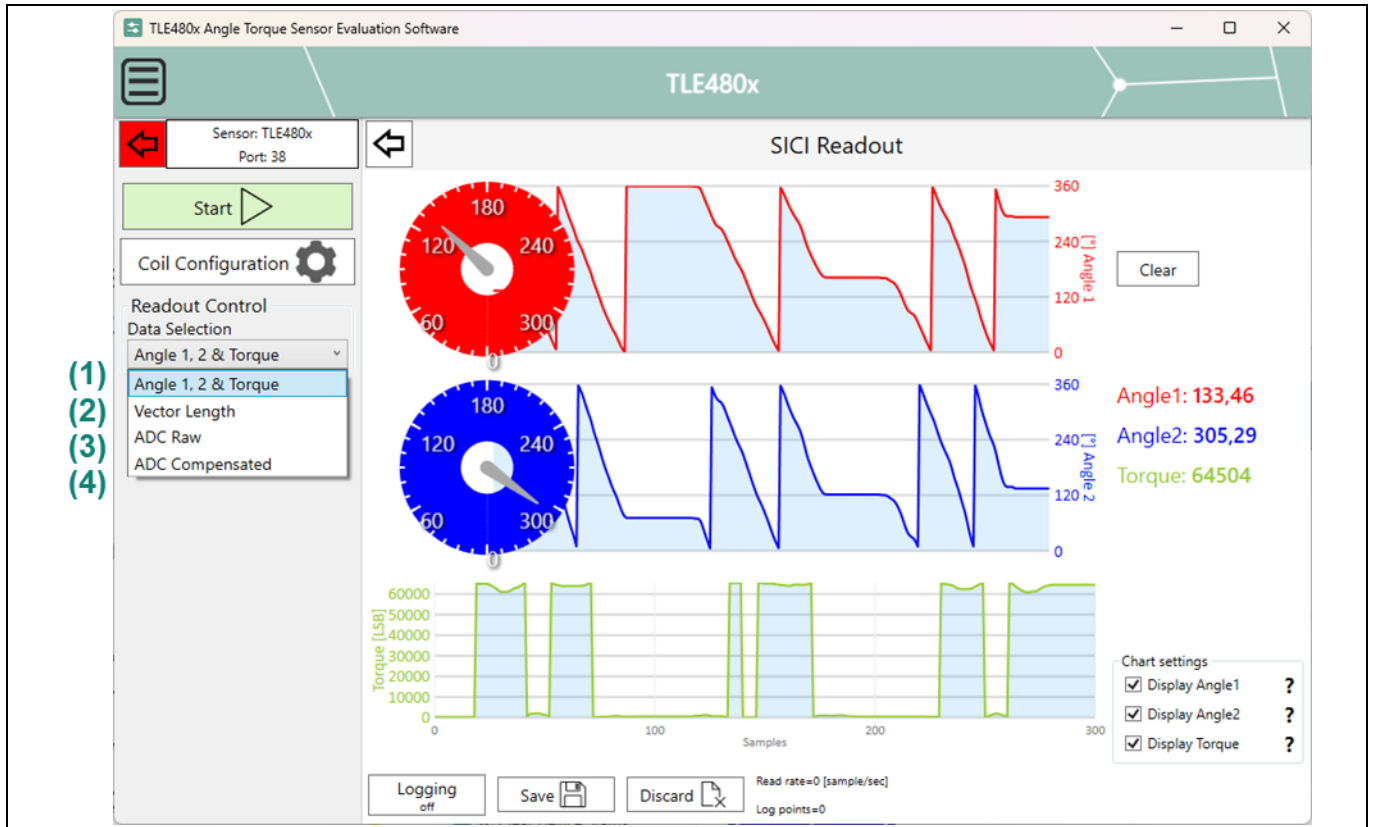

Figure 17 SICI Readout view

All received data can be logged in csv format. This contains raw and processed data. The software logs a maximum of 1 million frames. Logging data is kept between switching views. Sensor is put in test/programming mode upon selecting one of the configuration views (“SICI Readout Mode” or “Memory Map”). Test Mode is checked before issuing a reset command as to keep any volatile settings in case of configuration view change. The opened view contains the feature coil configuration for easy access of basic coil design settings.

TLE 4801/03 Evaluation board user guide

Evaluation software and system setup

3.4.1 SICI Readout view – Angle 1/2 & Torque

This view displays, plots and logs the sensor's Angle1/2 & Torque DSP registers content:

- 2 angular gauges for Angle1/2 (and their cartesian projections). The displayed angle values are processed from raw register values in degrees, 360° range (1, 2)
- 1 cartesian chart for torque value. Value is displayed raw in [LSB] (3)
- Labels for displaying numeric values (4)
- The user can opt to disable any plot (this will not be displayed, but still logged in case this feature is enabled) (5)
- Plotted data can be cleared by pressing the “Clear” button (6)
- Data can be logged by enabling the toggle “Logging” button. This view logs in csv format all raw data for each register read and processed data (calculated angles) (7)

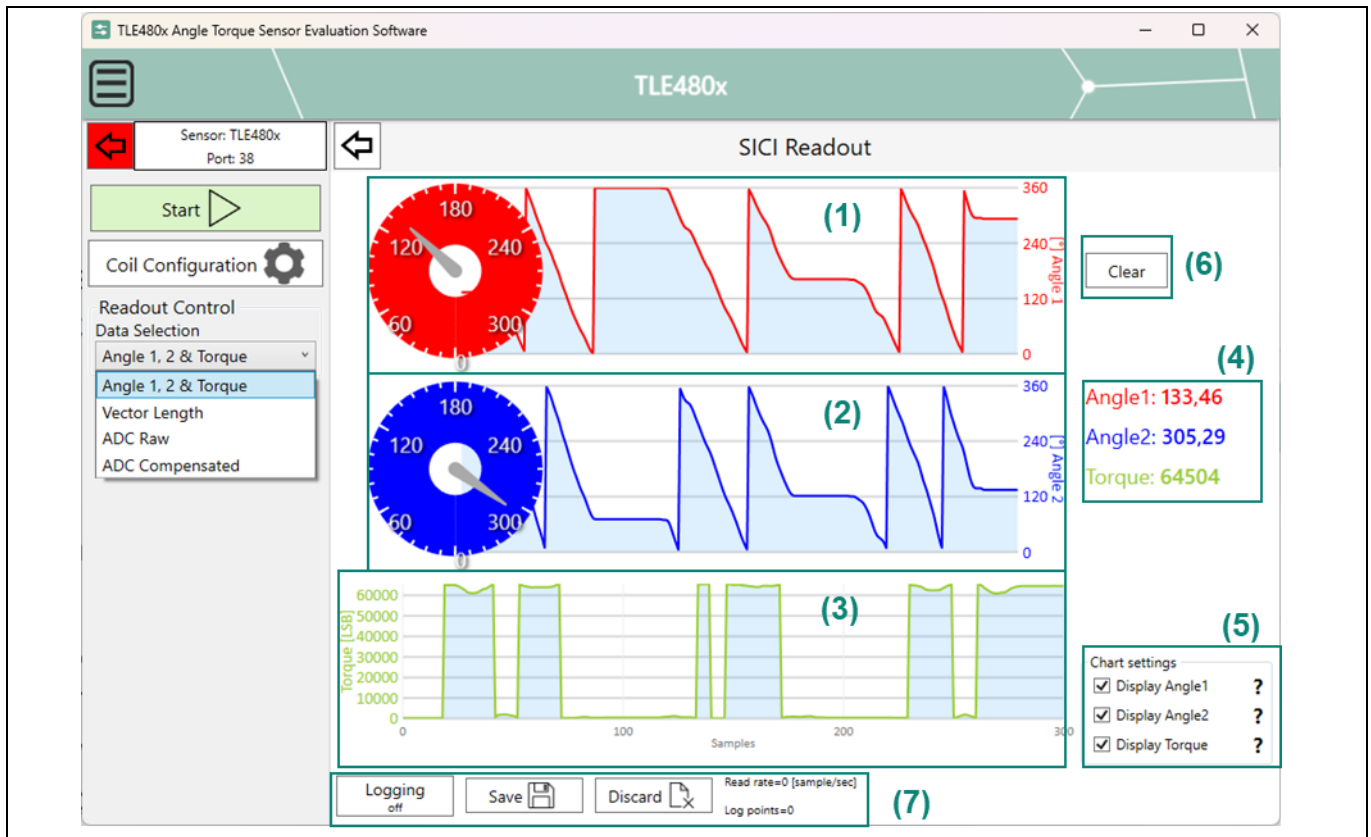

Figure 18 SICI Readout view, displays, plots and logs

TLE 4801/03 Evaluation board user guide

Evaluation software and system setup

3.4.2 SICI Readout view – Vector Length

This view displays, plots and logs the sensor's Vector Length1/2 & ADC1/2 Range registers content:

- 2 cartesian charts for ADC1/2 Vector Length + Range data pairs with different Y axis. Vector Length is displayed in [mV] and ADC Range in [LSB] + text decoding (1,2)
- Labels for displaying numeric and text values (3)
- Plotted data can be cleared by pressing the “Clear” button (4)
- Data can be logged by enabling the toggle “Logging” button. This view logs in CSV format all raw data for each register read and processed data (5)

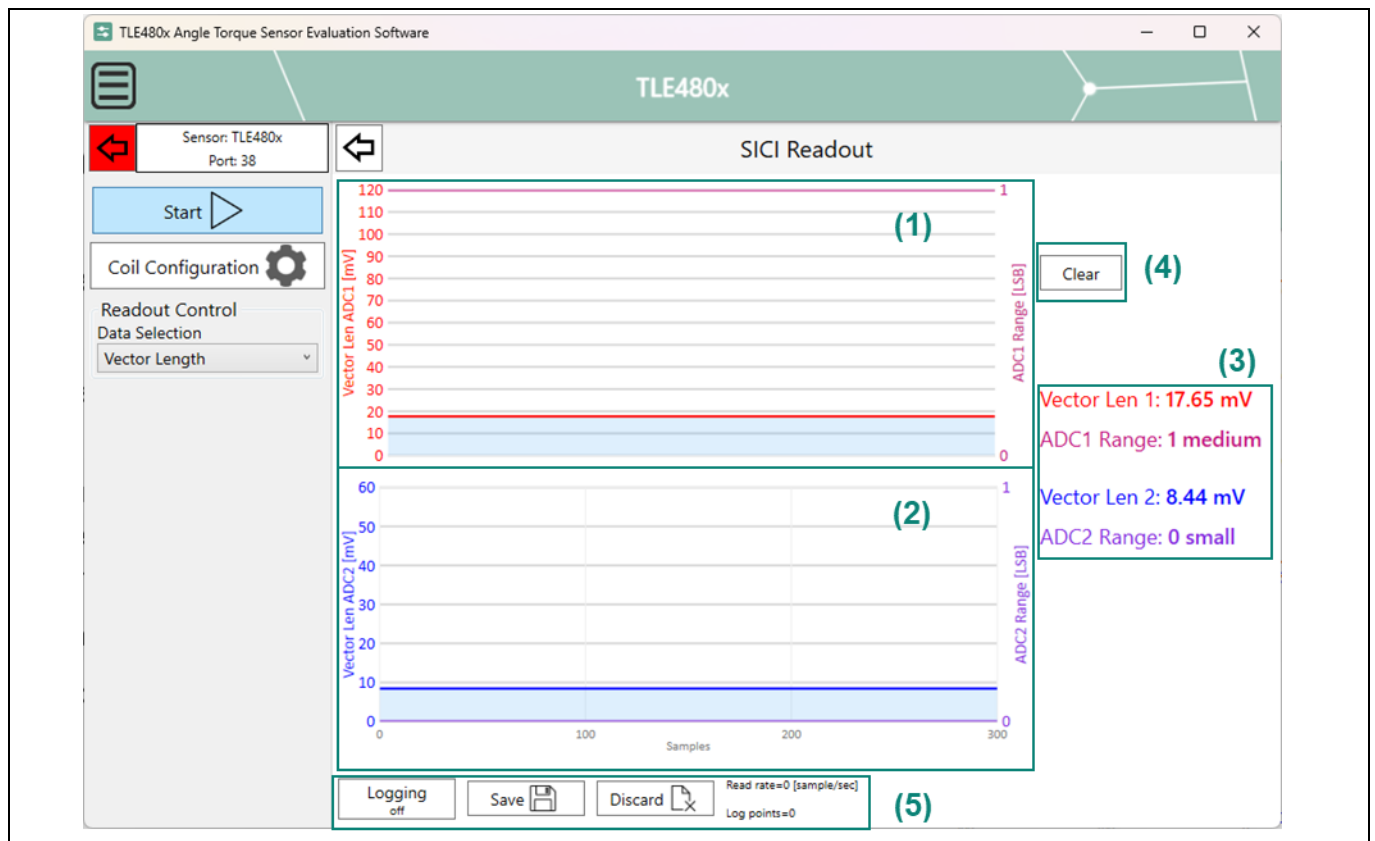

Figure 19 SICI Readout view, vector length

TLE 4801/03 Evaluation board user guide

Evaluation software and system setup

3.4.3 SICI Readout view – ADC Raw

This view displays, plots and logs the sensor’s raw uncompensated ADC1/2 X/Y registers content:

- 2 cartesian charts for ADC1/2 X + Y combined values (2 line series sharing the same axes). ADC X/Y are displayed in signed values [DEC] (1,2)
- Labels for displaying numeric values (3)
- Plotted data can be cleared by pressing the “Clear” button (4)
- Data can be logged by enabling the toggle “Logging” button. This view logs in CSV format all signed register values (5)



Figure 20 SICI Readout view, ADC Raw

TLE 4801/03 Evaluation board user guide

Evaluation software and system setup

3.4.4 SICI Readout view – ADC Compensated

This view displays, plots and logs the sensor's offset and gain compensated ADC1/2 X/Y registers content:

- 2 cartesian charts for ADC1/2 X + Y combined values (2 line series sharing the same axes). ADC X/Y are displayed in signed values [DEC] (1,2)
- Labels for displaying numeric values (3)
- Plotted data can be cleared by pressing the “Clear” button (4)
- Data can be logged by enabling the toggle “Logging” button. This view logs in CSV format all signed register values (5)

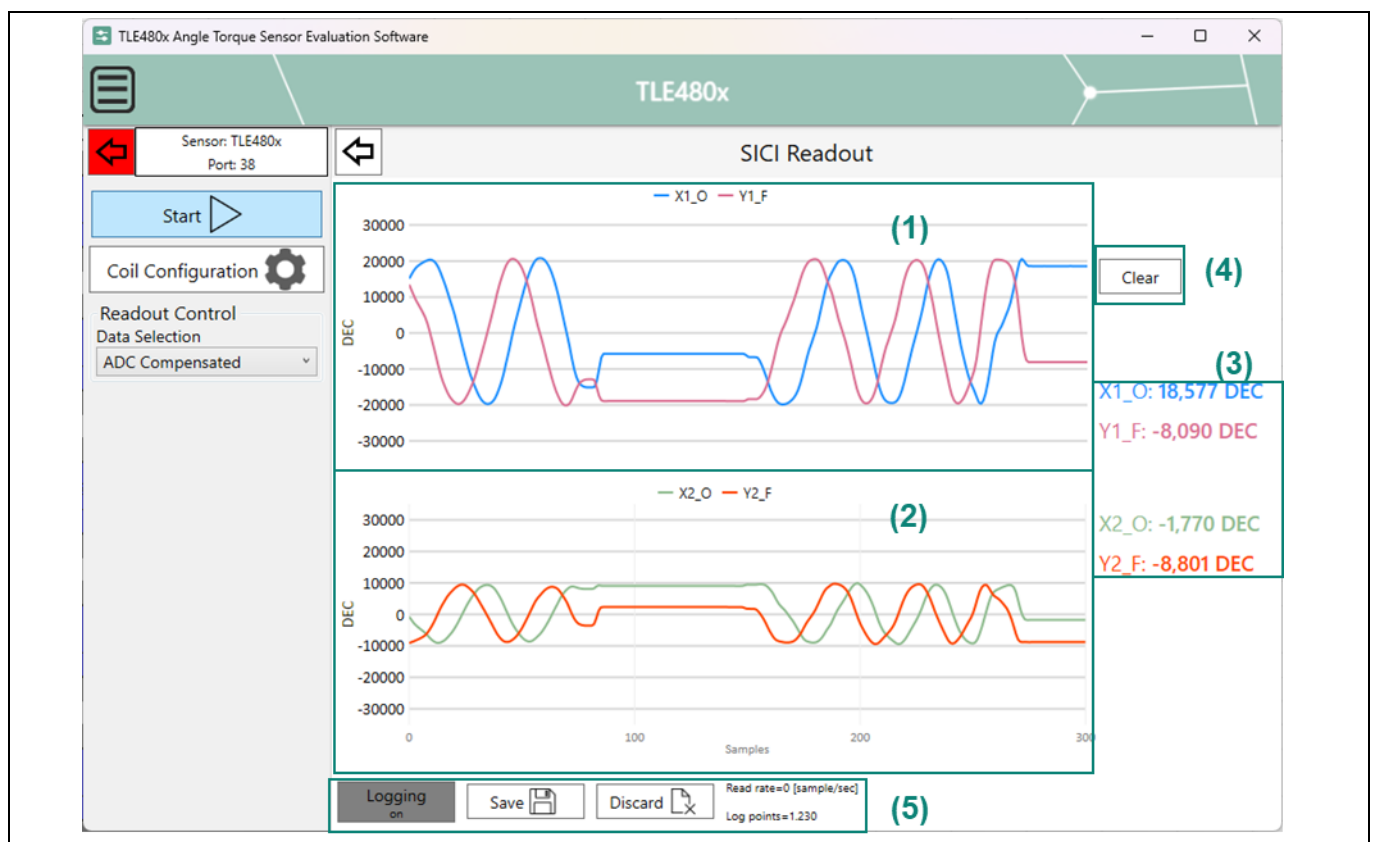

Figure 21 SICI Readout view, ADC compensated

TLE 4801/03 Evaluation board user guide

Evaluation software and system setup

3.4.5 SICI Readout view – Coil Configuration Window

This window is accessible by pressing the corresponding button in the control panel (1). This window offers ease of access to the “Coil Configuration” parameters:

- Number of poles for ADC1/2 (2)
- Inversion of mechanical angle (3)
- Direction change of angle1/2 value (4)
- Security feature disable (!*Valid only for TLE4802) (5)

To activate the settings or read the settings from CMTP, the buttons for Read, Write, Power-On Reset (6) are available:

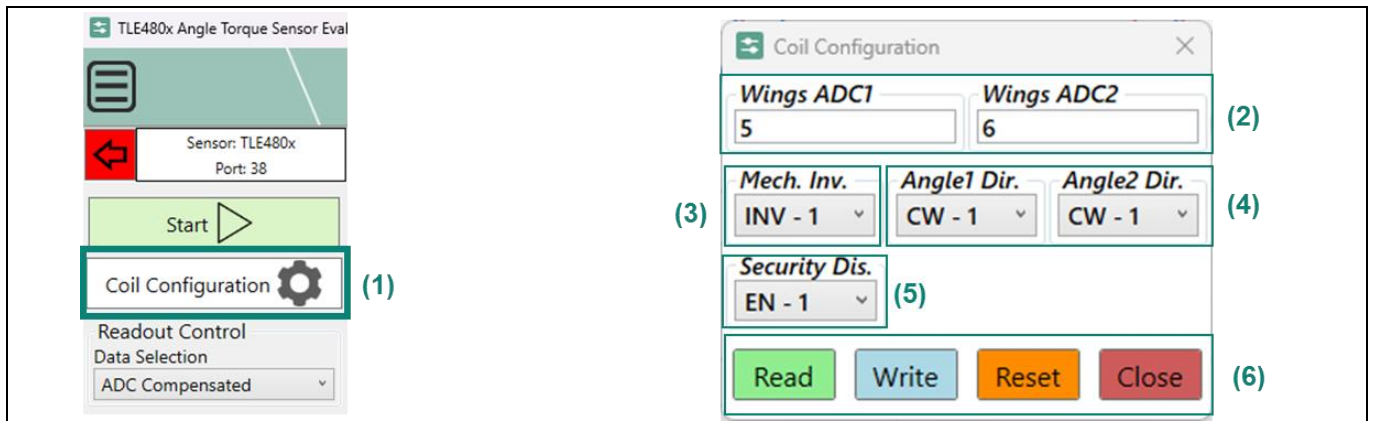

Figure 22 SICI Readout view, coil configuration window access and features

TLE 4801/03 Evaluation board user guide

Evaluation software and system setup

3.5 Memory Map View

3.5.1 CMTMP memory map

The application in the memory map view can read CMTMP memory and internal registers. The CMTMP memory contains addresses [256 ... 316] including IFX exclusive addresses. The user may write only in the addresses [273 ... 307]. As the CMTMP is limited in writing cycles, the remaining writing cycles are displayed in the CMTMP memory map view. For details please refer to the user manual.

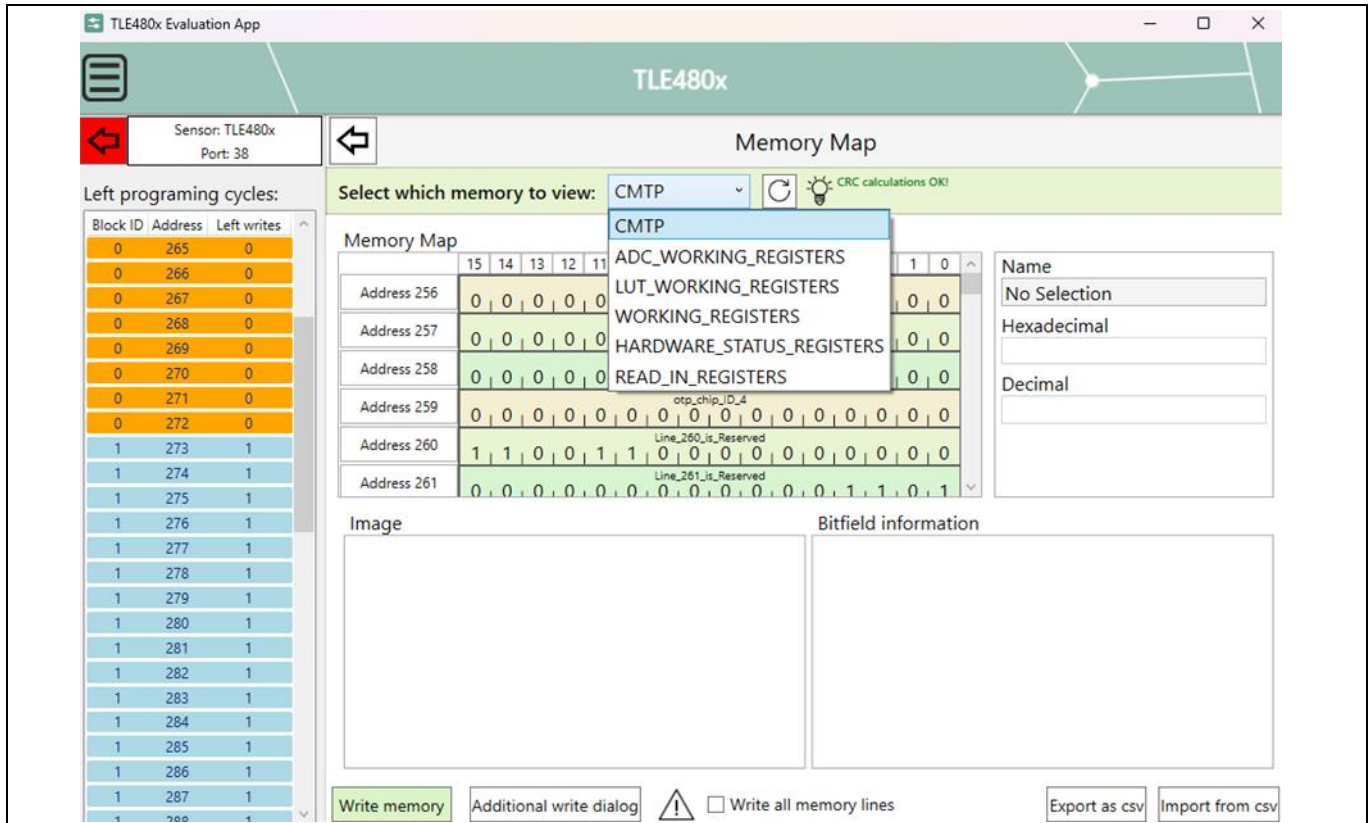

Figure 23 Memory map view, CMTMP

To write the address of interest, the user needs to select a bit field (1) in the address of interest and writes the content in either hexadecimal or decimal (2). After filling the desired addresses, “Write memory” needs to be clicked (3). To allow entering the Readout mode, the software checks if the CMTMP was written at least once. If this is true, only changed lines will be written. If not, all lines will be written. The user has the option overwrite this option using the checkbox.

TLE 4801/03 Evaluation board user guide

Evaluation software and system setup

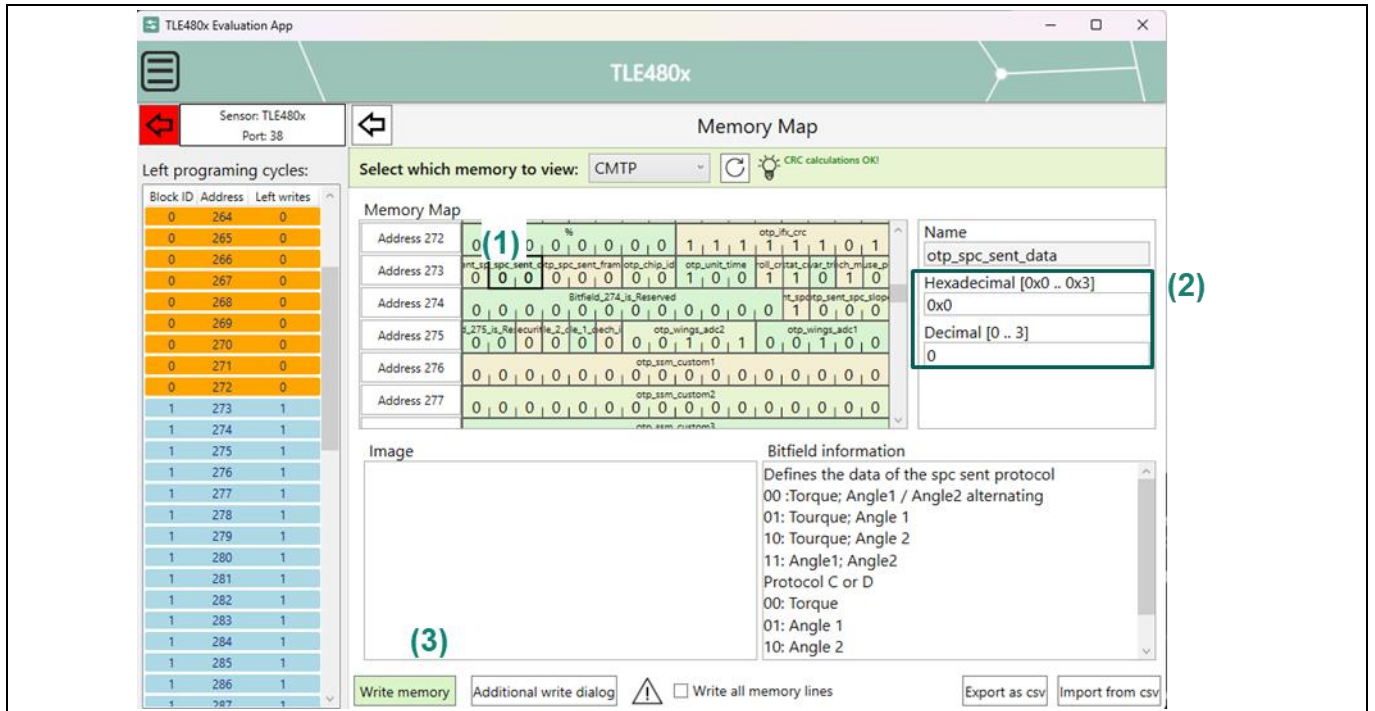

Figure 24 Memory map view, CMTTP writing procedure

The current memory configuration (as seen in the map view) can also be exported as a csv file by clicking “Export as csv”. Further a corresponding memory configuration file (csv format) can be imported for writable Memory Maps by clicking “Import from csv”. This is useful for writing full configurations of the sensor.

TLE 4801/03 Evaluation board user guide

Evaluation software and system setup

3.5.2 Internal registers

The software can read the internal registers, which are grouped by category like shown in the figure below.

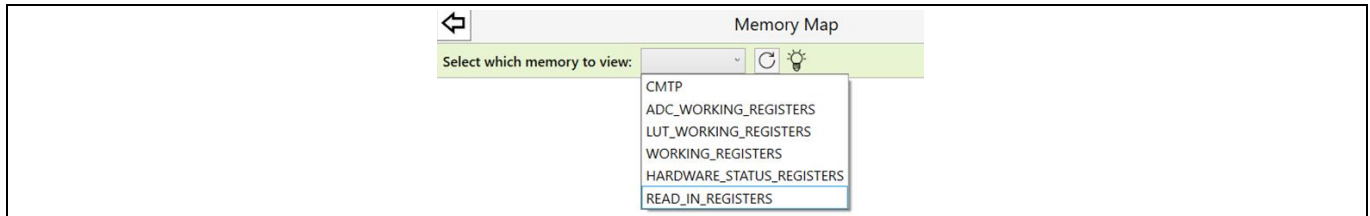

Figure 25 Memory map view, internal register grouping

All registers are implemented as read-only except the “READ_IN_REGISTERS”. These can be programmed via SICI and only the normal 5 V voltage level is applied. This way it is possible to fine tune values and to read via SICI the raw values or angular digital values through the working registers afterwards. After reset, in contrast to the CMTMP section, the values programmed here through SICI are again filled with the CMTMP values.

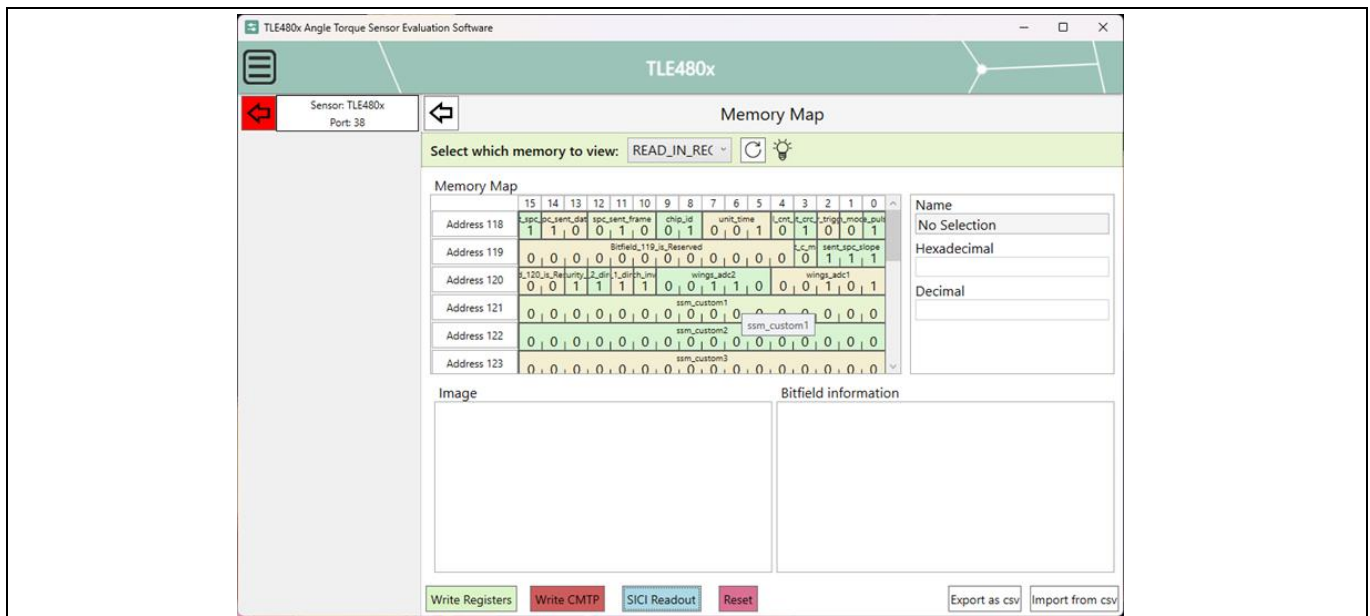

Figure 26 Memory map view, READ-IN-REGISTERS

In the Read In Registers view the user can fine tune the values and:

- Write the Read In Registers with the new values
- Write the CMTMP with the Read In Registers configuration (Only the changed lines will be written)
- Start a continuous readout of Working Registers for calibration purposes
- Reset the Read In Registers with the CMTMP values
- Export as csv. Here the user must select two options:
 - Read In Registers CSV format
 - Read In Registers converted to CMTMP CSV format

TLE 4801/03 Evaluation board user guide

Revision history

Revision history

Document revision	Date	Description of changes
1.0	2025-07-15	Initial release

Trademarks

All referenced product or service names and trademarks are the property of their respective owners.

Edition 2025-07-15

Published by

Infineon Technologies AG

81726 Munich, Germany

© 2025 Infineon Technologies AG.

All Rights Reserved.

Do you have a question about this document?

Email: erratum@infineon.com

Document reference

Warnings

Due to technical requirements products may contain dangerous substances. For information on the types in question please contact your nearest Infineon Technologies office.

Except as otherwise explicitly approved by Infineon Technologies in a written document signed by authorized representatives of Infineon Technologies, Infineon Technologies' products may not be used in any applications where a failure of the product or any consequences of the use thereof can reasonably be expected to result in personal injury.