

MOTIX™ TLE9844QXC

Microcontroller with LIN/CXPI interfaces and power switches

Features

- 32-bit Arm[®]* Cortex[®]-M0 core: up to 25 MHz clock frequency
- On-chip memory: 64 KB flash (including EEPROM), 4 KB EEPROM (emulated in flash), 768 bytes 100 time programmable memory (100TP), 4 KB RAM, boot ROM for start-up firmware and flash routines
- Power saving modes: Microcontroller unit slow-down mode, Sleep mode with cyclic sense option, Cyclic wake-up during sleep mode, Stop mode with cyclic sense option
- Single power supply from 3.0 V to 28 V, integrated 5 V voltage supply VDDEXT for external loads, e.g. hall sensors
- Integrated LIN/CXPI transceiver, embedded CXPI controller
- On-chip OSC and PLL for clock generation
- Measurement unit: 8-bit ADC with 7 channels for voltage and temperature supervision, 10-bit ADC with 13 channels (6 analog inputs, 4 HV MON inputs and battery sense), on-chip temperature and battery voltage measurement
- 1 high-side switch, 2 low-side switches with PWM capability
- LIN bootstrap loader to program the flash via LIN (LIN BSL)
- Temperature grade-1 device

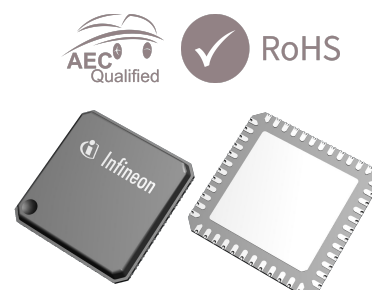

Product type	Package	Marking
TLE9844QXC	VQFN-48-37	TLE9844QXC
	VQFN-48-79	

Potential applications

- Window lift

Product validation

Qualified for automotive applications.

Product validation according to AEC-Q100.

* Arm and Cortex are registered trademarks of Arm Limited, UK

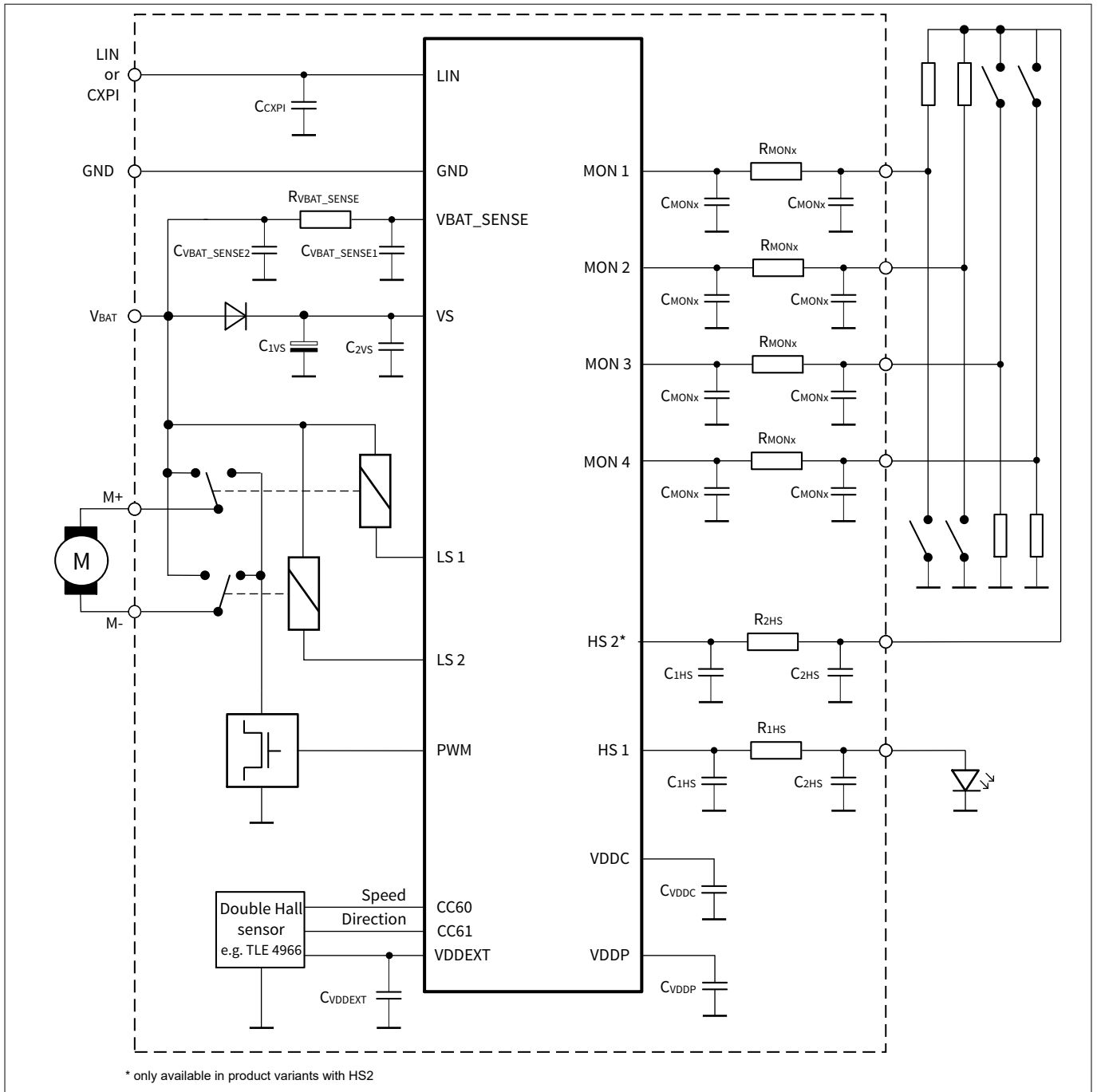

Figure 1 Typical application

Table of contents

	Features	1
	Potential applications	1
	Product validation	1
	Table of contents	3
1	Block diagram	8
2	Device pinout and pin configuration	9
2.1	Device pinout	9
2.2	Pin configuration	10
3	Introduction	13
4	Modes of operation	14
5	Power management unit (PMU)	16
5.1	Features	16
5.2	Introduction	16
5.2.1	Block diagram	17
5.2.2	PMU modes overview	19
5.3	Power supply generation (PGU)	20
5.3.1	Voltage regulator 5.0 V (VDDP)	20
5.3.2	Voltage regulator 1.5 V (VDDC)	21
5.3.3	External voltage regulator 5.0 V (VDDEXT)	22
5.3.4	Low- V_S operation	23
6	System control unit - digital modules (SCU-DM)	24
6.1	Features	24
6.2	Introduction	24
6.2.1	Block diagram	25
6.3	Clock generation unit	26
6.3.1	Low precision clock	26
6.3.2	High precision oscillator circuit (OSC_HP)	26
6.3.2.1	External input clock mode	26
6.3.2.2	External crystal mode	26
6.3.3	Clock control unit	28
7	System control unit - power modules (SCU-PM)	30
7.1	Description of the power modules system control unit	30
7.2	Introduction	30
7.2.1	Block diagram	30
8	Arm® Cortex®-M0 core	31
8.1	Features	31

Table of contents

8.2	Introduction	32
8.2.1	Block diagram	32
9	Address space organization	33
10	Memory control unit	35
10.1	Features	35
10.2	Introduction	35
10.2.1	Block diagram	35
11	NVM module (flash memory)	37
11.1	Definitions	38
11.1.1	General definitions	38
12	Interrupt system	40
12.1	Features	40
12.2	Introduction	40
12.2.1	Overview	40
13	Watchdog timer (WDT1)	42
13.1	Features	42
13.2	Introduction	43
14	GPIO ports and peripheral I/O	44
14.1	Features	44
14.2	Introduction	45
14.2.1	Port 0 and port 1	45
14.2.2	Port 2	46
14.3	Port implementation details	47
14.3.1	Port 0	47
14.3.1.1	Port 0 functions	47
14.3.2	Port 1	50
14.3.2.1	Port 1 functions	50
14.3.3	Port 2	52
14.3.3.1	Port 2 functions	52
15	General purpose timer units (GPT12)	54
15.1	Features	54
15.1.1	Features block GPT1	54
15.1.2	Features block GPT2	54
15.2	Introduction	54
15.2.1	Block diagram GPT1	55
15.2.2	Block diagram GPT2	56
16	Timer2 and Timer21	57
16.1	Features	57
16.2	Introduction	57
16.2.1	Timer2 and Timer21 modes overview	57

Table of contents

17	Capture/compare unit 6 (CCU6)	59
17.1	Feature set overview	59
17.2	Introduction	60
17.2.1	Block diagram	60
18	UART1/UART2	61
18.1	Features	61
18.2	Introduction	61
18.2.1	Block diagram	62
18.3	UART modes	63
19	LIN/CXPI transceiver (TRX)	64
19.1	Features	64
19.1.1	General functional features	64
19.1.2	Mode of operation	64
19.1.3	Special features	64
19.1.4	Slope mode features	64
19.1.5	Wake-up features	64
19.2	Introduction	65
19.2.1	Block diagram	66
20	CXPI protocol controller (MXCXPI)	68
20.1	Features	68
20.2	Introduction	69
20.2.1	Block diagram	69
21	High-speed synchronous serial interface SSC1/SSC2	70
21.1	Features	70
21.2	Introduction	70
21.2.1	Block diagram	71
22	Measurement unit	72
22.1	Features	72
22.2	Introduction	72
22.2.1	Block diagram	73
23	Measurement core module (incl. ADC2)	74
23.1	Features	74
23.2	Introduction	74
23.2.1	Block diagram	74
24	10-bit analog digital converter (ADC1)	75
24.1	Features	75
24.2	Introduction	76
24.2.1	Block diagram	76
25	High-voltage monitor input	77

Table of contents

25.1	Features	77
25.2	Introduction	77
25.2.1	Block diagram	77
26	High-side switch	78
26.1	Features	78
26.2	Introduction	79
26.2.1	Block diagram	79
26.2.2	General	79
27	Low-side switch	80
27.1	Features	80
27.2	Introduction	81
27.2.1	Block diagram	81
27.2.2	General	81
28	Application information	82
28.1	Relay window lift application diagram	82
28.2	Connection of N.C. / N.U. pins	83
28.3	Connection of unused pins	84
28.4	Connection of P0.2 for SWD debug mode	84
28.5	Connection of TMS	84
28.6	ESD immunity according to ISO10605	85
29	Electrical characteristics	86
29.1	General characteristics	86
29.1.1	Absolute maximum ratings	86
29.1.2	Functional range	88
29.1.3	Current consumption	89
29.1.4	Thermal resistance	91
29.1.5	Timing characteristics	91
29.2	Power management unit (PMU)	93
29.2.1	PMU input voltage VS	93
29.2.2	PMU I/O supply parameters VDDP	93
29.2.3	PMU core supply parameters VDDC	95
29.2.4	VDDEXT voltage regulator 5.0 V	96
29.2.5	VPRE voltage regulator (PMU subblock) parameters	98
29.2.5.1	Load sharing of VPRE regulator	98
29.2.6	Power down voltage regulator (PMU subblock) parameters	99
29.3	System clocks	100
29.3.1	Electrical characteristics oscillators and PLL	100
29.3.2	External clock parameters XTAL1, XTAL2	101
29.4	Flash parameters	103
29.4.1	Flash characteristics	103
29.5	Parallel ports (GPIO)	104

Table of contents

29.5.1	Description of keep and force current	104
29.5.2	DC parameters port 0, port 1, TMS, reset	105
29.5.3	DC parameters port 2	107
29.5.4	Operating conditions	108
29.6	LIN/CXPI transceiver (TRX)	110
29.6.1	Transceiver general characteristics	110
29.6.1.1	Transmitter interface	111
29.6.1.2	Receiver interface	111
29.6.2	LIN transceiver	112
29.6.2.1	Receiver interface	113
29.6.2.2	Transmitter interface	114
29.6.2.3	LIN waveform diagrams	116
29.6.3	CXPI transceiver	116
29.6.3.1	Receiver interface	117
29.6.3.2	Transmitter interface	118
29.6.3.3	CXPI waveform diagrams	121
29.6.4	Parameter test circuit	127
29.7	CXPI protocol controller (MXCXPI)	128
29.7.1	Figures	128
29.8	High-speed synchronous serial interface	129
29.8.1	SSC timing	129
29.9	Measurement unit	130
29.9.1	Electrical characteristics	130
29.9.2	Central temperature sensor module	133
29.9.2.1	Electrical characteristics	133
29.10	ADC1 (10-bit)	134
29.10.1	ADC1 reference voltage	134
29.10.2	Electrical characteristics ADC1 (10-bit)	134
29.11	High-voltage monitoring input	136
29.11.1	Electrical characteristics	136
29.12	High side switches	137
29.12.1	Electrical characteristics	137
29.13	Low-side switches	140
29.13.1	Electrical characteristics	140
30	Package information	142
31	Abbreviations	144
32	Revision history	146
	Disclaimer	147

1 Block diagram

1 Block diagram

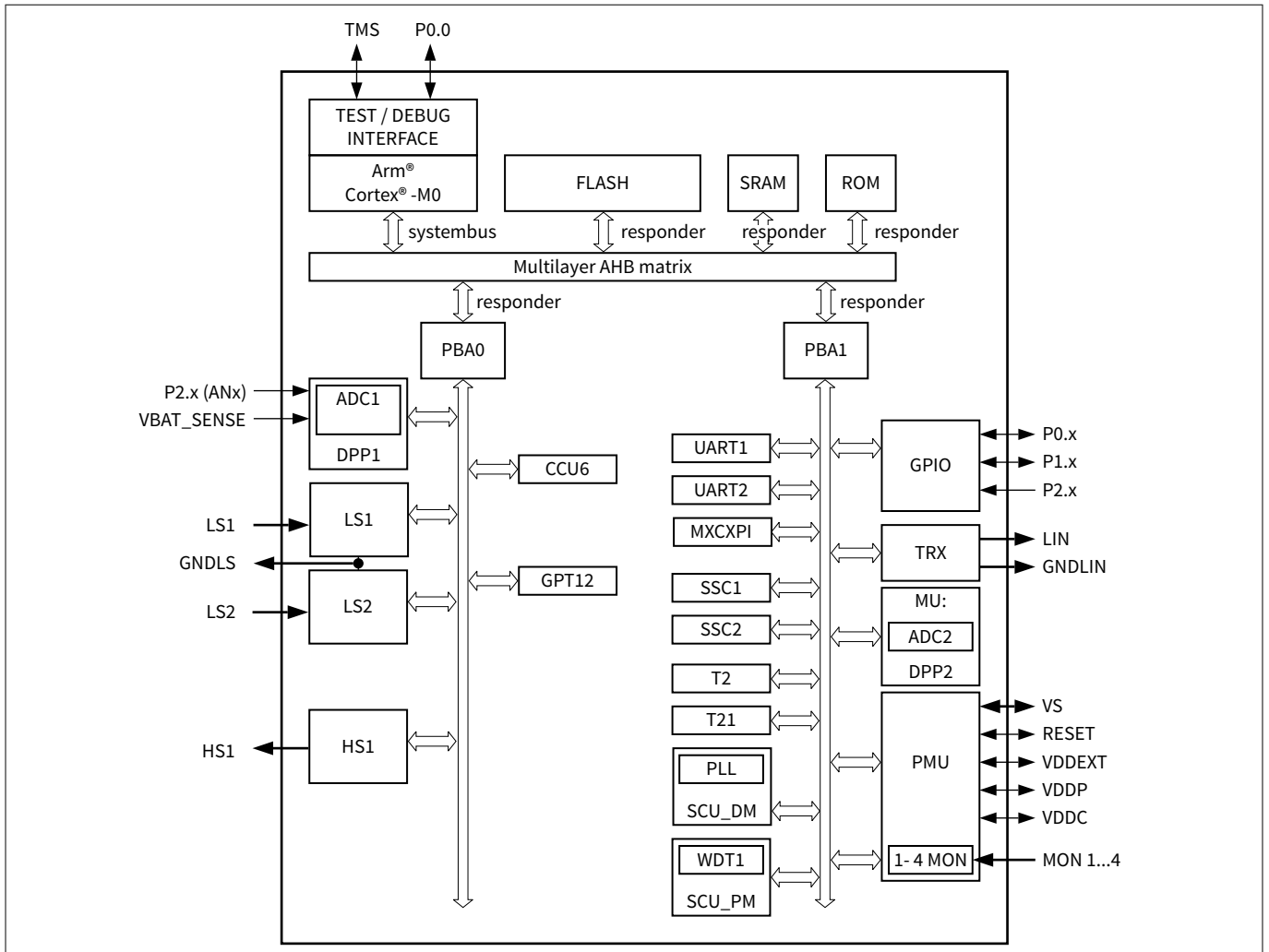

Figure 2 Block diagram, TLE9844QXC

2 Device pinout and pin configuration

2 Device pinout and pin configuration

2.1 Device pinout

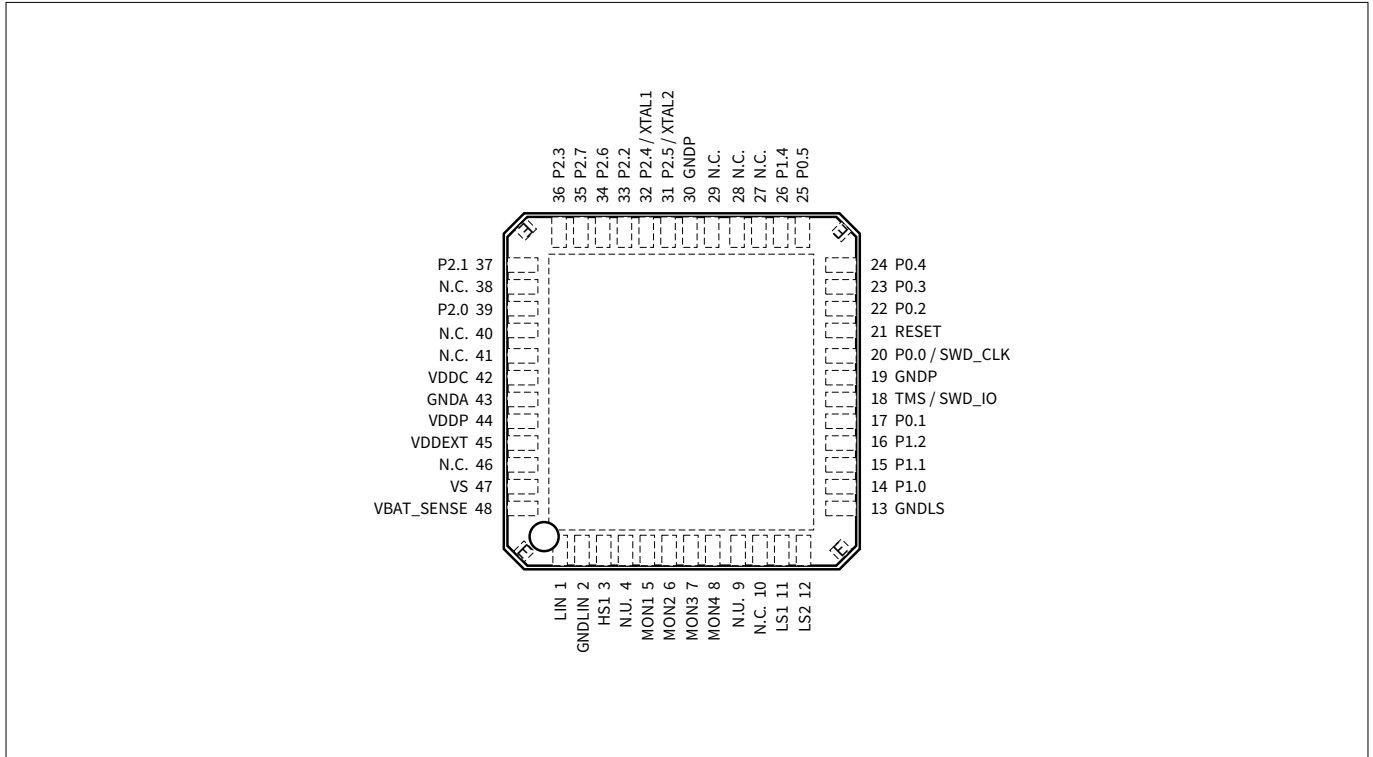

Figure 3 Device pinout, TLE9844QXC

2 Device pinout and pin configuration

2.2 Pin configuration

After reset, all pins are configured as input (except the power supply pins and the LIN pin). The table below shows the device pin types, functions and reset states. Not all alternate functions are listed, for more details see [Chapter 14](#).

Table 1 Pin definitions and functions

Symbol	Pin number	Type	Reset state	Function	
P0				Port 0 is a 6-bit bidirectional general purpose I/O port. Alternate functions can be assigned and are listed in the port description section. Only main functions are listed below.	
P0.0	20	I/O	I/PU	SWD_CLK GPIO	Serial wire debug clock General purpose IO Alternate function mapping see Table 7
P0.1	17	I/O	I/PU	GPIO	General purpose IO Alternate function mapping see Table 7
P0.2	22	I/O	I/PD	GPIO	General purpose IO Alternate function mapping see Table 7
P0.3	23	I/O	I/PU	GPIO	General purpose IO Alternate function mapping see Table 7
P0.4	24	I/O	I/PU	GPIO	General purpose IO Alternate function mapping see Table 7
P0.5	25	I/O	I/PU	GPIO	General purpose IO Alternate function mapping see Table 7
P1				Port 1 is a 4-bit bidirectional general purpose I/O port. Alternate functions can be assigned and are listed in the port description section. Only main functions are listed below.	
P1.0	14	I/O	I	GPIO	General purpose I/O Alternate function mapping see Table 8
P1.1	15	I/O	I	GPIO	General purpose I/O Alternate function mapping see Table 8
P1.2	16	I/O	I	GPIO	General purpose I/O Alternate function mapping see Table 8
P1.4	26	I/O	I	GPIO	General purpose I/O Alternate function mapping see Table 8
P2				Port 2 is a 8-bit general purpose I/O port. Alternate functions can be assigned and are listed in the port description section. Only the main functions are listed below.	
P2.0	39	I	I	AN0	ADC1 analog input channel 12 Alternate function mapping see Table 9

(table continues...)

2 Device pinout and pin configuration

Table 1 (continued) Pin definitions and functions

Symbol	Pin number	Type	Reset state	Function	
P2.1	37	I	I	AN1	ADC1 analog input channel 7 Alternate function mapping see Table 9
P2.2	33	I	I	AN2	ADC1 analog input channel 8 Alternate function mapping see Table 9
P2.3	36	I	I	AN3	ADC1 analog input channel 9 Alternate function mapping see Table 9
P2.4	32	I	I	XTAL1	External oscillator input Alternate function mapping see Table 9
P2.5	31	I/O	I	XTAL2	External oscillator output Alternate function mapping see Table 9
P2.6	34	I	I	AN6	ADC1 analog input channel 10 Alternate function mapping see Table 9
P2.7	35	I	I	AN7	ADC1 analog input channel 11 Alternate function mapping see Table 9

Power supply

VS	47	P	–	Battery supply input	
VDDP	44	P	–	I/O port supply (5.0 V). Do not connect external loads. For buffer and bypass capacitors	
VDDC	42	P	–	Core supply (1.5 V during active mode, reduced voltage during stop mode). Do not connect external loads. For buffer/bypass capacitor	
VDDEXT	45	P	–	External voltage supply output (5.0 V, 20 mA)	
GNDLS	13	P	–	Low-side ground LS1, LS2	
GNDP	19, 30	P	–	Core supply ground	
GND A	43	P	–	Analog supply ground	
GNDLIN	2	P	–	LIN/CXPI ground	

Monitor inputs

MON1	5	I	I	High voltage monitor input 1	
MON2	6	I	I	High voltage monitor input 2	
MON3	7	I	I	High voltage monitor input 3	
MON4	8	I	I	High voltage monitor input 4	

High-side switch/low-side switch outputs

LS1	11	O	Hi-Z	Low-side switch output 1	
LS2	12	O	Hi-Z	Low-side switch output 2	
HS1	3	O	Hi-Z	High-side switch output 1	

(table continues...)

2 Device pinout and pin configuration

Table 1 (continued) Pin definitions and functions

Symbol	Pin number	Type	Reset state	Function
LIN/CXPI interface				
<i>LIN</i>	1	I/O	PU	LIN/CXPI bus interface input/output
Others				
<i>TMS</i>	18	I	I/PD	TMS SWD_IO Test mode select input Serial wire debug input/output
<i>RESET</i>	21	I/O	I/O/PU	Reset input/output, not available during sleep mode
<i>VBAT_SENSE</i>	48	I	I	Battery supply voltage sense input
N.C.	27, 28, 29, 38, 40, 41	–	–	No internal connection, should be connected to GND
	10, 46	–	–	No internal connection, should be connected to GND or left open
N.U.	4	–	–	Not used, should be connected to VS or left open
	9	–	–	Not used, should be connected to GND
<i>EP</i>	–	–	–	Exposed pad, connect to GND

Type and default state abbreviations used in the table above:

- I/O: Input/output
- I: Input only
- O: Output only
- P: Power supply
- PU: Pull-up enabled
- PD: Pull-down enabled
- Hi-Z: High-impedance

3 Introduction

3 Introduction

This highly integrated circuit contains analog and digital functional blocks. For system and interface control an embedded 32-bit Arm® Cortex®-M0 microcontroller is included. For internal and external power supply purposes, on-chip low drop-out regulators are existent. An internal oscillator (no external components necessary) provides a cost effective and suitable clock in particular for LIN or CXPI responder nodes. As communication interface, a LIN/CXPI transceiver and several high-voltage monitor inputs with adjustable threshold and filters are available. Furthermore, one high-side switch (e.g. for driving LEDs or powering switches), two low-side switches (e.g. for relays) and several general purpose input/outputs (GPIO) with pulse-width modulation (PWM) capabilities are available.

The microcontroller unit supervision and system protection including reset feature is controlled by a programmable window watchdog. A cyclic wake-up circuit, supply voltage supervision and integrated temperature sensors are available on-chip.

All relevant modules offer power saving modes in order to support terminal 30 connected automotive applications. A wake-up from the power saving mode is possible via a LIN or CXPI bus message, via the monitoring inputs or repetitive with a programmable time period (cyclic wake-up).

The integrated circuit is available in a package with 0.5 mm pitch and is designed to withstand the challenging conditions of automotive applications.

4 Modes of operation

4 Modes of operation

The TLE9844QXC has several operational modes mainly to support low power consumption requirements.

Active mode

In Active mode all modules are activated and the TLE9844QXC is fully operational.

Stop mode

The Stop mode is one out of two major low-power modes. The transition to the low-power modes is done by setting the respective bits in the mode control register. In Stop mode the embedded microcontroller is still powered allowing faster wake-up reaction times, but not clocked. A wake-up from this mode is possible by LIN/CXPI bus activity, the high-voltage monitor input pins or the respective 5 V GPIOs.

Sleep mode

The Sleep mode is a major low-power mode. The transition to the low-power modes is done by setting the respective bits in the microcontroller unit mode control register. The sleep time is configurable. In Sleep mode the embedded microcontroller power supply is deactivated, allowing the lowest system power consumption, but the wake-up time is longer compared to the Stop mode. In this mode a 64-bit wide buffer for data storage is available. A wake-up from this mode is possible by LIN/CXPI bus activity or the high-voltage monitor input pins and cyclic wake. A wake-up from Sleep mode behaves similar to a power-on reset. While changing into Sleep mode, no incoming wake-requests are lost (that means no dead-time). It is possible to enter Sleep mode even with LIN/CXPI dominant.

Cyclic wake-up

The cyclic wake-up is a special feature of the Sleep and Stop mode. The enabling of cyclic wake-up is done by first setting the respective bits in the mode control register followed by the SLEEP or STOP command. Additional to the cyclic wake-up behavior (wake-up after a programmable time period), the wake-up sources of the normal Stop mode and Sleep mode are available.

Cyclic sense

The cyclic sense is a special feature of the Sleep mode and the Stop mode. The enabling to the cyclic is done by first setting the respective bits in the mode control register followed by the STOP or SLEEP command. For example, in cyclic sense the high-side switch can be switched on periodically for biasing some switches. The wake-up condition is configurable, when the sense result of defined monitor inputs at a window of interest changed compared to the previous wake-up period or reached a defined state respectively. In this case the Active mode is entered immediately.

The following table shows the possible power mode configurations of each major module or function respectively.

Table 2 Power mode configurations

Module/function	Active mode	Sleep mode	Stop mode	Comment
VPRE, VDDP, VDDC	ON	OFF	ON	–
VDDEXT	ON/OFF	OFF	Cyclic/ON/OFF	–
HSx	ON/OFF	Cyclic	Cyclic	Cyclic sense
LSx	ON/OFF	OFF	OFF	–
LIN/CXPI TRX	ON/OFF	Wake-up only/OFF	Wake-up only/OFF	–

(table continues...)

4 Modes of operation

Table 2 (continued) Power mode configurations

Module/function	Active mode	Sleep mode	Stop mode	Comment
MONx (wake-up)	n.a.	Disabled/static/cyclic	Disabled/static/cyclic	Cyclic: combined with HS=on
MONx (measurement)	ON/OFF	OFF	OFF	Available on all channels
VS sense	ON/OFF brownout detection	Brownout detection	Brownout detection	Brownout detection done in PCU
VBAT_SENSE	ON/OFF	OFF	OFF	–
GPIO 5V	ON	OFF	ON	–
WDT1	ON	OFF	OFF	–
CYCLIC WAKE	n.a.	Cyclic wake-up/cyclic sense/OFF	Cyclic wake-up/cyclic sense/OFF	Cyclic sense with HS; wake-up needs MC for enter sleep mode again
Measurement	ON ¹⁾	OFF	OFF	–
Microcontroller unit	ON/slow-down/STOP	OFF	OFF	–
CLOCK GEN (MC)	ON	OFF	OFF	–
LP_CLK (f_{LP_CLK})	ON	OFF	OFF	WDT1
LP_CLK2 (f_{LP_CLK2})	ON	ON	ON	For cyclic wake-up

1) May not be switched off due to safety reasons.

Wake-up source prioritization

All wake-up sources have the same priority. In order to handle the asynchronous nature of the wake-up sources, the first wake-up signal will initiate the wake-up sequence. Nevertheless all wake-up sources are latched in order to provide all wake-up events to the application software. Only the software can clear the wake-up source flags. It is ensured, that no wake-up event is lost since the wake-up events are captured at anytime (Active mode, transitions, Sleep mode, Stop mode).

As default wake-up sources, MON inputs and cyclic wake are activated after power-on reset, LIN/CXPI is disabled as wake-up source by default.

Wake-up levels and transitions

The wake-up can be triggered by rising, falling or both signal edges for each monitor input and GPIOs individually.

5 Power management unit (PMU)

5.1 Features

- System modes control (start-up, sleep, stop and active)
- Power management (cyclic wake)
- Control of system voltage regulators with diagnosis (overload, short, overvoltage)
- Fail safe mode detection and operation in case of system errors (watchdog fail)
- Wake-up sources configuration and management (LIN/CXPI TRX, MON, GPIOs)
- System error logging

5.2 Introduction

The power management unit is responsible for generating all needed voltage supplies for the embedded MCU (VDDC, VDDP) and the external supply (VDDEXT). Additionally, the PMU provides well defined sequences for the system mode transitions and generates hierarchical reset priorities. The reset priorities control the reset behavior of all system functionalities especially the reset behavior of the embedded MCU. Another purpose of the power management unit is to ensure the fail safe behavior of the system IC.

Therefore the power management unit controls all system modes including the corresponding transitions. To ensure this system-commander role of the PMU, an independent logic supply and system clock are internally implemented and they work independently from the MCU clock.

5 Power management unit (PMU)

5.2.1 Block diagram

The following figure shows the structure of the power management unit. The table below describes the submodules more detailed.

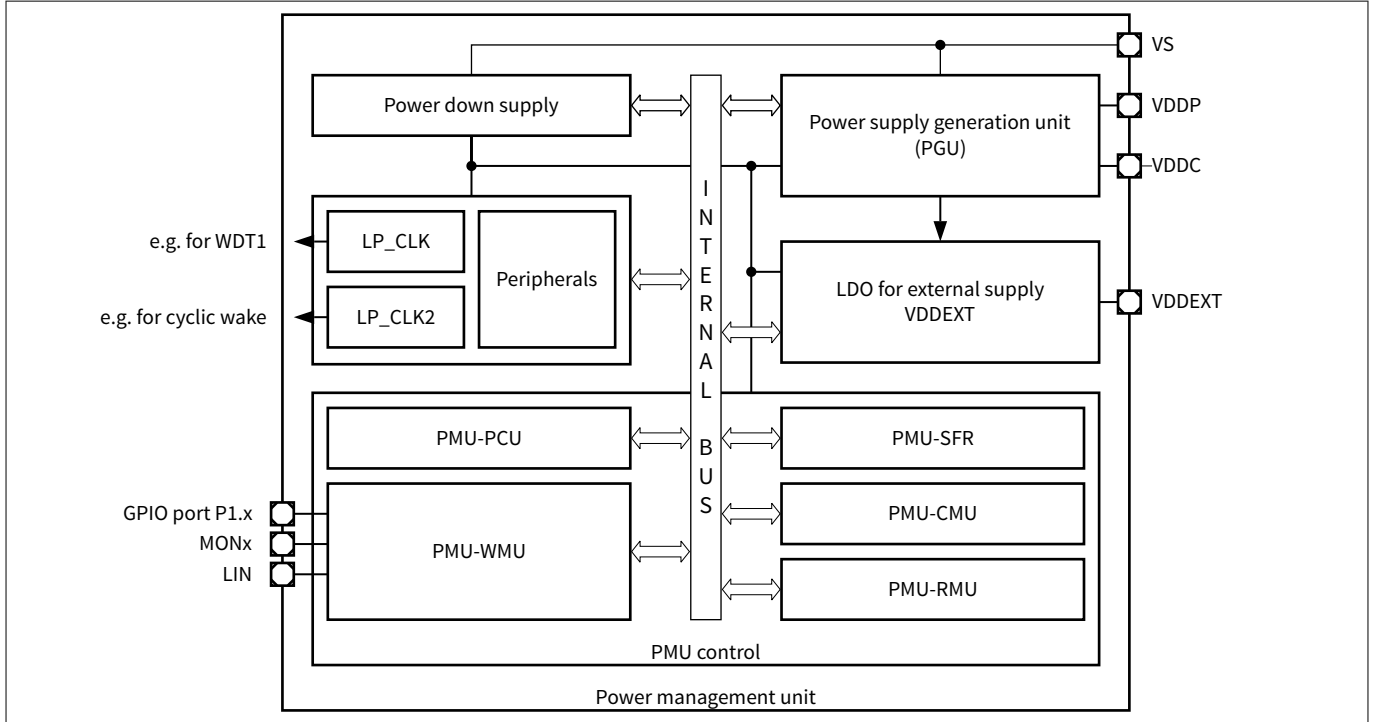

Figure 4 Power management unit block diagram

Table 3 Description of PMU submodules

Mod. name	Modules	Functions
Power down supply	Independent supply voltage generation for PMU	This supply is dedicated to the PMU to ensure an independent operation from generated power supplies (VDDP, VDDC)
LP_CLK (= f_{LP_CLK})	<ul style="list-style-type: none"> • Clock source for all PMU submodules • Backup clock source for system • Clock source for WDT1 	<p>This ultra low power oscillator generates the clock for the PMU</p> <p>This clock is also used as backup clock for the system in case of PLL clock failure and as independent clock source for WDT1</p>
LP_CLK2 (= f_{LP_CLK2})	Clock source for PMU	This ultra low power oscillator generates the clock for the PMU in stop mode and in the cyclic modes
Peripherals	Peripheral blocks of PMU	These blocks include the analog peripherals to ensure a stable and fail safe PMU start-up and operation (bandgap, bias)
Power supply generation unit (PGU)	Voltage regulators for VDDP and VDDC	This block includes the voltage regulators for the pad supply (VDDP) and the core supply (VDDC)

(table continues...)

5 Power management unit (PMU)

Table 3 (continued) Description of PMU submodules

Mod. name	Modules	Functions
VDDEXT	Voltage regulator for VDDEXT to supply external modules (e.g. sensors)	This voltage regulator is a dedicated supply for external modules
PMU-SFR	All PMU relevant extended special function registers	This module contains all PMU relevant registers, which are needed to control and monitor the PMU
PMU-PCU	Power control unit of the PMU	This block is responsible for controlling all power related actions within the PGU module. It also contains all regulator related diagnosis like under- and overvoltage detection, overcurrent and short circuit diagnoses
PMU-WMU	Wake-up management unit of the PMU	This block is responsible for controlling all wake-up related actions within the PMU module
PMU-CMU	Cyclic management unit of the PMU	This block is responsible for controlling all actions within cyclic mode
PMU-RMU	Reset management unit of the PMU	This block generates resets triggered by the PMU like undervoltage or short circuit reset, and passes all resets to the relevant modules and their register. A reset status register with every reset source is available

5 Power management unit (PMU)

5.2.2 PMU modes overview

The PMU offers a set of four operating modes:

- Active mode: The embedded system supplies, VDDP and VDDC, are operational and VDDEXT can be enabled by the user software
- Sleep mode: All embedded system supplies, VDDC, VDDP and VDDEXT, are turned off
- Fail Sleep mode: Same as for Sleep mode
- Stop mode: VDDP, VDDEXT and VDDC are operational. VDDEXT can be kept off by the user or be used for cyclic sense

Active mode is the PMU state that allows full operation of the embedded system, so is the one that allows for the user software and application to run.

In order to decrease power consumption during idle application instances, the user can set the system and the power supply generation in Stop mode or Sleep mode. In case of predefined fail safe scenarios the PMU will be able to lead the system in Fail Sleep mode, which also allows for low power consumption.

5 Power management unit (PMU)

5.3 Power supply generation (PGU)

5.3.1 Voltage regulator 5.0 V (VDDP)

This module represents the 5 V voltage regulator, which provides the pad supply for the parallel port pins and other 5 V analog functions (e.g. LIN/CXPI transceiver).

Features

- 5 V low-drop voltage regulator
- Overcurrent monitoring and shutdown with MCU signaling (interrupt)
- Overvoltage monitoring with MCU signaling (interrupt)
- Undervoltage monitoring with MCU signaling (interrupt)
- Undervoltage monitoring with reset (undervoltage reset, V_{DDPUV})
- Overtemperature shutdown with MCU signaling (interrupt)
- Pre-regulator for VDDC regulator
- GPIO supply
- Pull-down current source at the output for sleep mode only (typ. 5 mA)

The output capacitor C_{VDDP} is mandatory to ensure a proper regulator functionality.

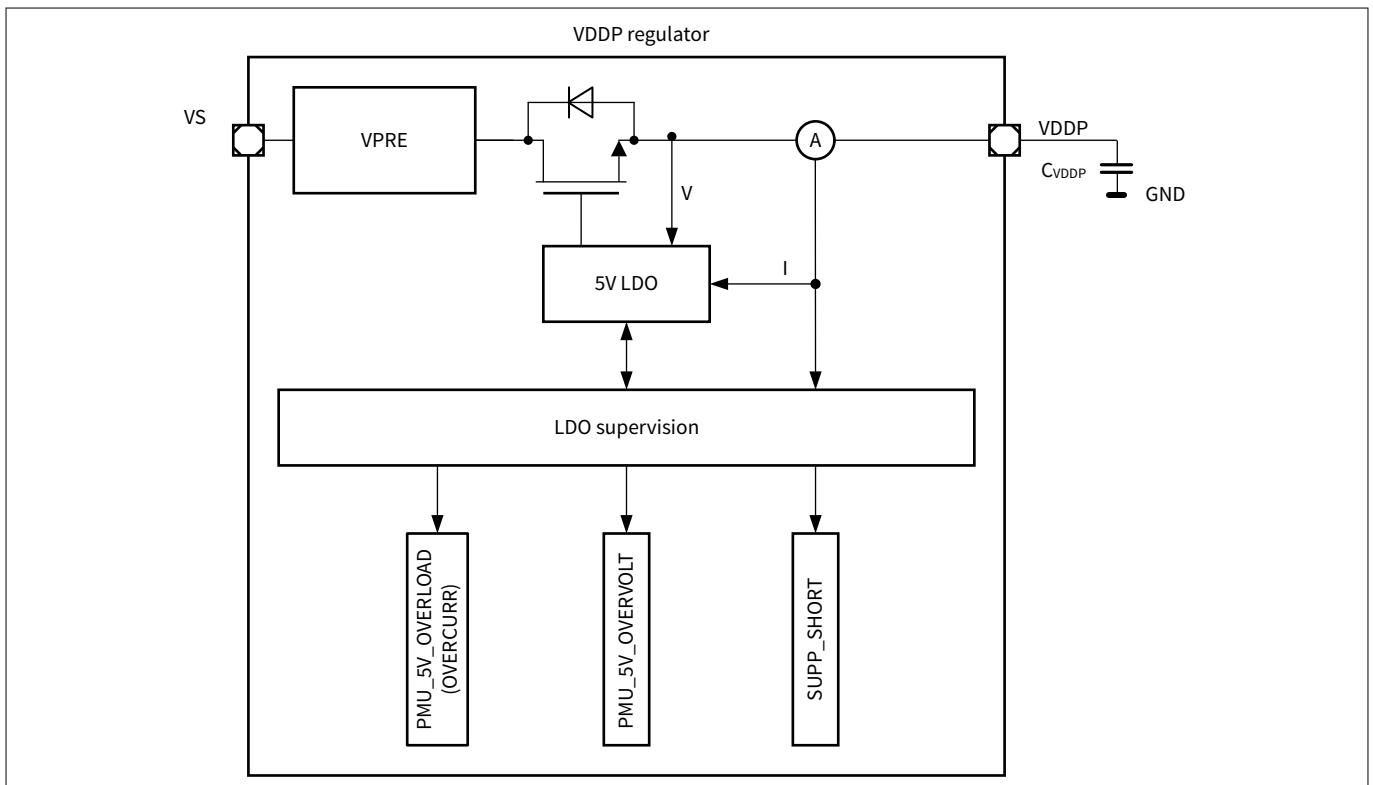

Figure 5 Module block diagram of VDDP voltage regulator

5 Power management unit (PMU)

5.3.2 Voltage regulator 1.5 V (VDDC)

This module represents the 1.5 V voltage regulator, which provides the supply for the microcontroller core, digital peripherals and other chip internal analog 1.5 V functions (e.g. ADC).

Features

- 1.5 V low-drop voltage regulator
- Overcurrent monitoring and shutdown with MCU signaling (interrupt)
- Overvoltage monitoring with MCU signaling (interrupt)
- Undervoltage monitoring with MCU signaling (interrupt)
- Undervoltage monitoring with reset
- Overtemperature shutdown with MCU signaling (interrupt)
- Pull-down current source at the output for sleep mode only (typ. 100 μ A)

The output capacitor C_{VDDC} is mandatory to ensure a proper regulator functionality.

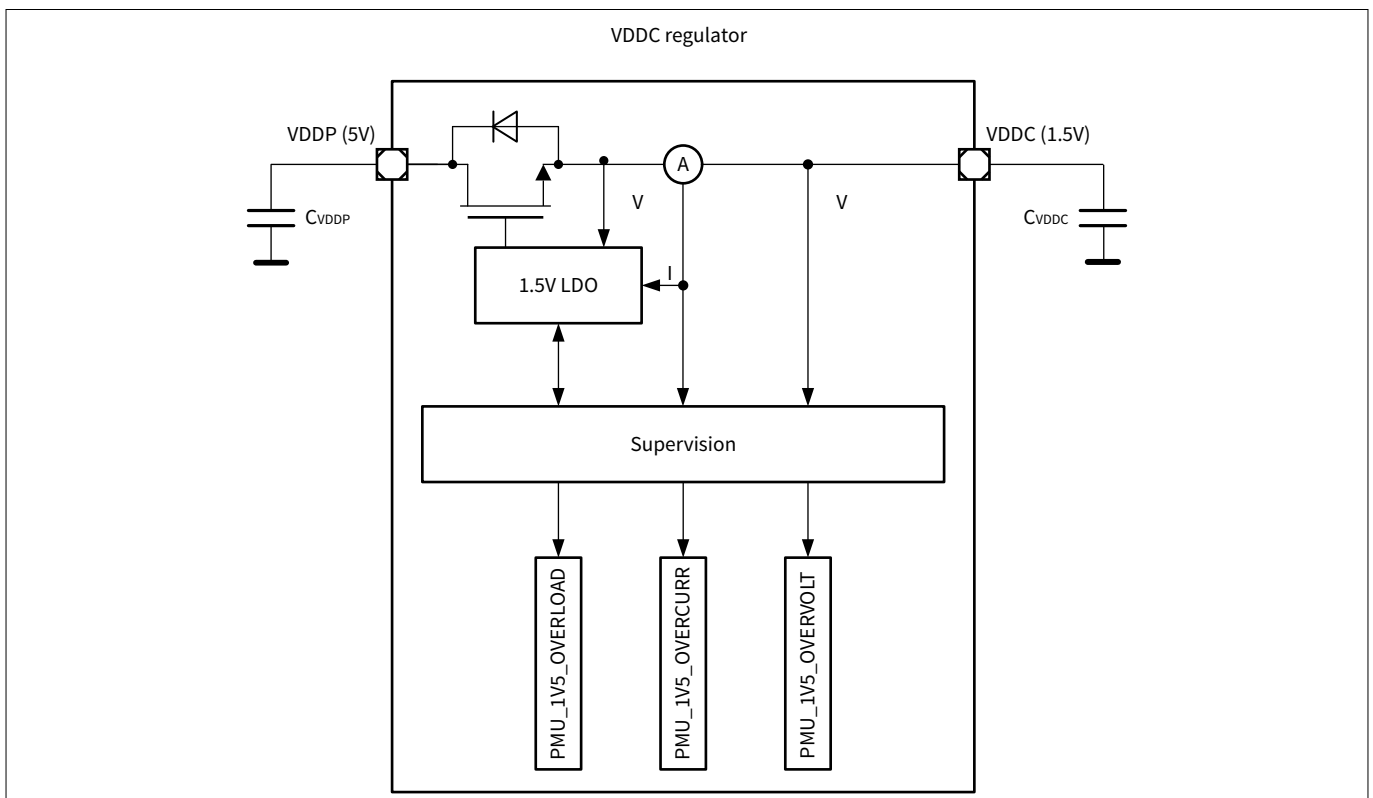

Figure 6 Module block diagram of VDDC voltage regulator

5 Power management unit (PMU)

5.3.3 External voltage regulator 5.0 V (VDDEXT)

This module represents the 5 V voltage regulator, which serves as a supply for external circuits. It can be used e.g. to supply an external sensor, LEDs or potentiometers.

Features

- Switchable (by software) +5 V, low-drop voltage regulator
- Switch-on undervoltage blanking time in order to drive small capacitive loads
- Intrinsic current limitation
- Undervoltage monitoring and shutdown with MCU signaling (interrupt)
- Overtemperature shutdown with MCU signaling (interrupt)
- Pull-down current source at the output for Sleep mode only (typ. 100 μ A)
- Cyclic sense option together with GPIOs (Stop mode only)
- Low current mode available to ensure reduced stop mode current consumption. In this mode current capability is reduced to I_{VDDEXT_LCM}

The output capacitor C_{VDDEXT} is mandatory to ensure a proper regulator functionality.

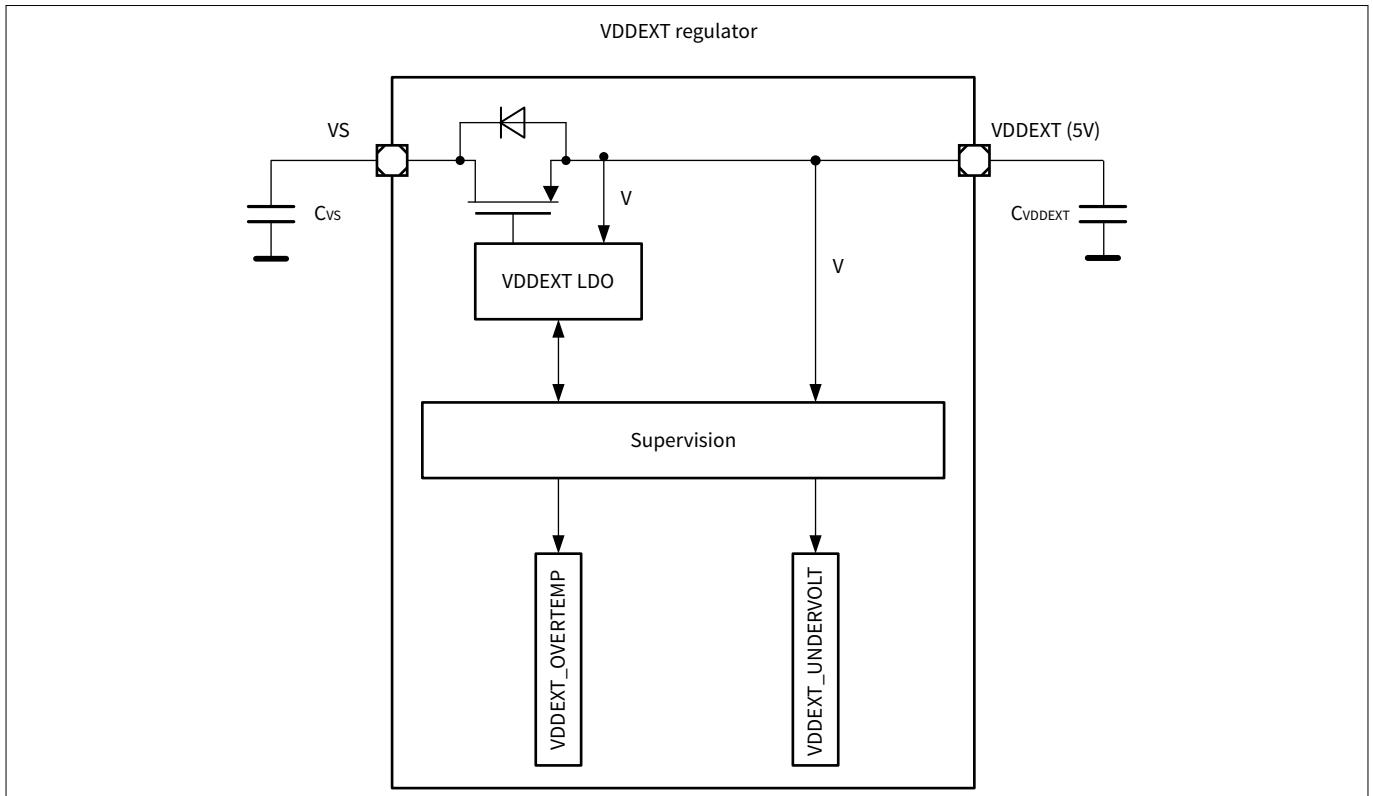

Figure 7 **Module block diagram**

5 Power management unit (PMU)

5.3.4 Low- V_S operation

The integrated VDDP regulator will enter dropout operation as the V_S pin voltage is dropping below the min. supply voltage. As a consequence the regulator will enter dropout and can no longer maintain its output voltage within the regulation limits.

The MCU subsystem remains fully functional down to the minimum extended supply voltage range.

Care should be taken while operating following peripherals under low-supply conditions:

- Low-side, high-side switches
- GPIOs
- Transceiver interface
- VDDEXT regulator

The following figure illustrates the operation under low-supply conditions:

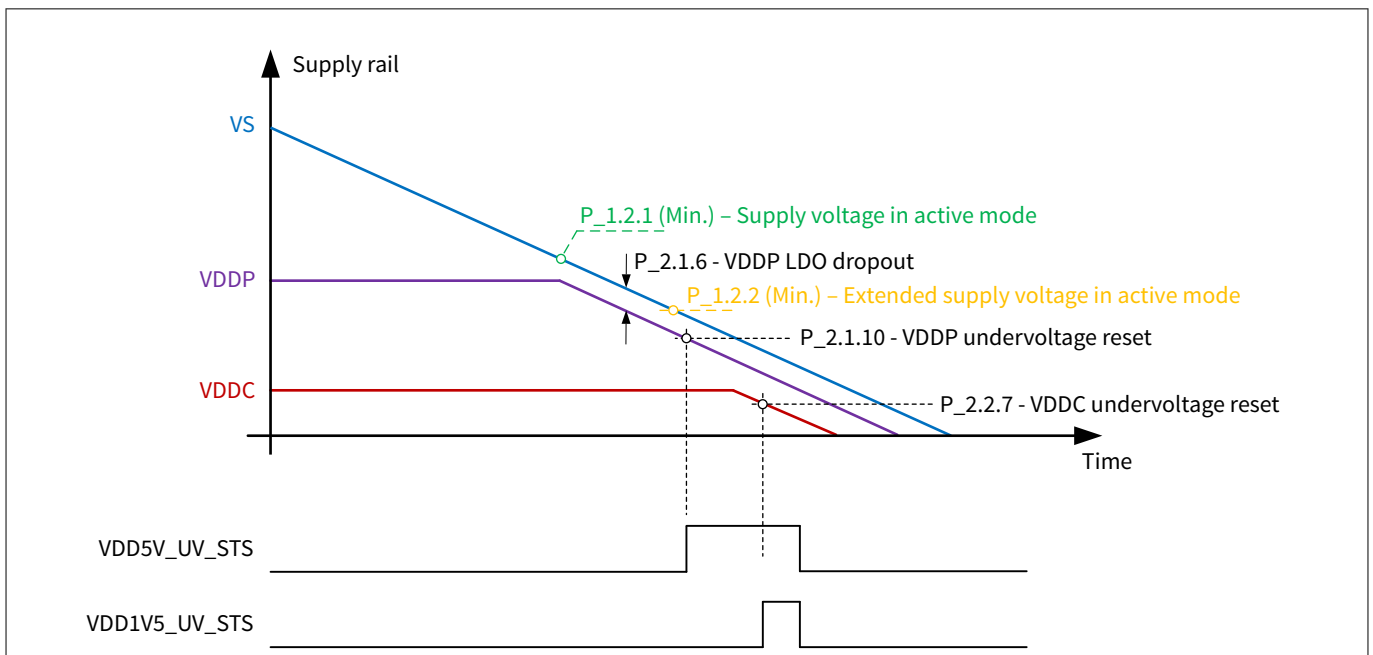

Figure 8 Low- V_S operation¹⁾

¹ P_*: See chapter "Electrical characteristics" for details.

6 System control unit - digital modules (SCU-DM)

6.1 Features

- Flexible clock configuration features
- Reset management of all system resets
- System modes control for all power modes (active, power down, sleep)
- Interrupt enabling for many system peripherals
- General purpose input output control
- Debug mode control of system peripherals

6.2 Introduction

The system control unit (SCU) supports all central control tasks in the TLE9844QXC. The SCU is made up of the following submodules:

- Clock system and control (CGU)
- Reset control (RCU)
- Power management (PCU)
- Interrupt management (ICU)
- General port control
- Flexible peripheral management
- Module suspend control
- Error detection and correction in data memory
- Miscellaneous control
- Register mapping

6 System control unit - digital modules (SCU-DM)

6.2.1 Block diagram

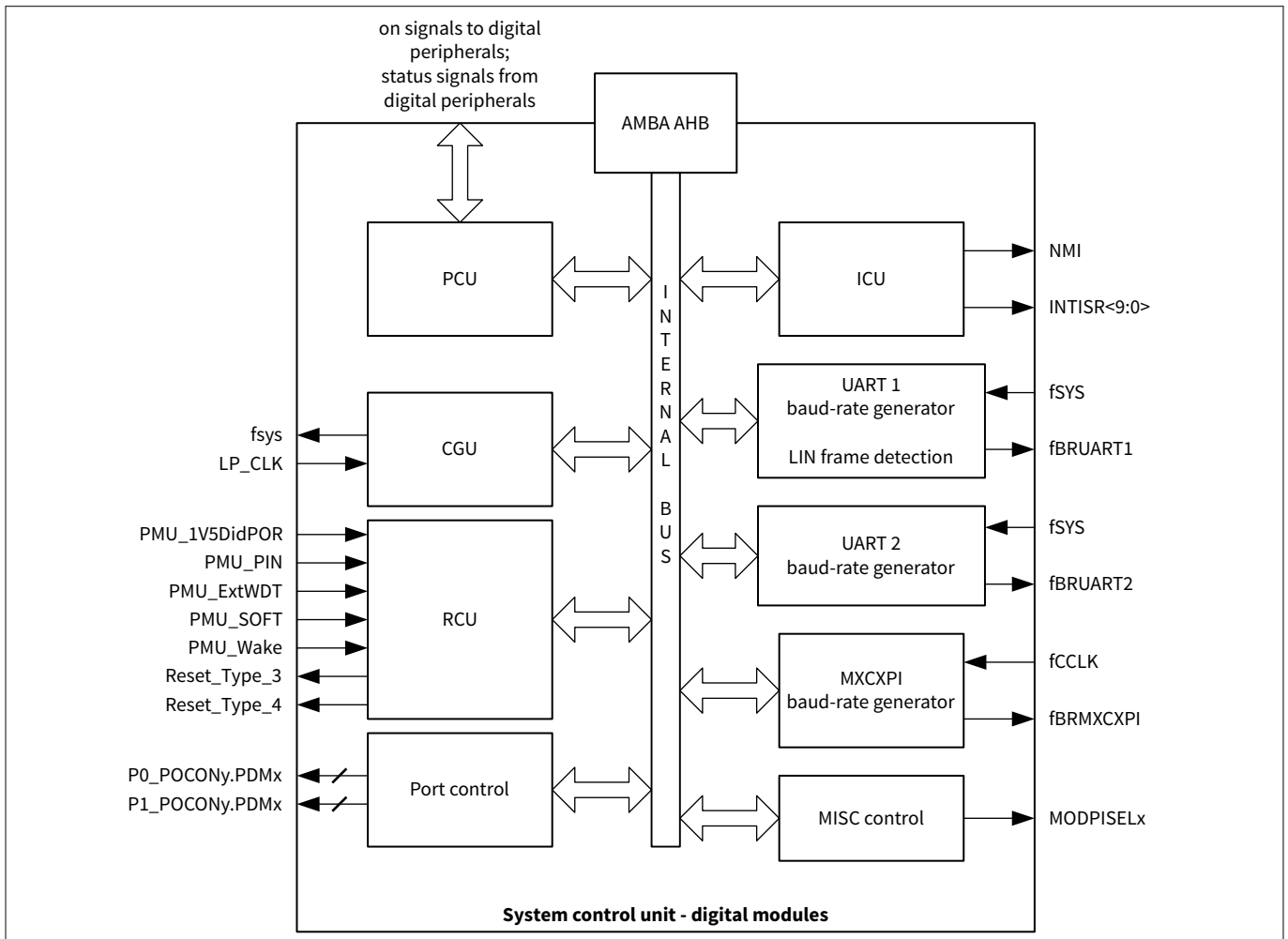

Figure 9 System control unit - digital modules block diagram

IO description of SCU_DM

- CGU:
 - f_{sys} : system clock
 - LP_CLK: low-power backup clock
- RCU:
 - 1V5DidPOR: undervoltage reset of power down supply
 - PMU_PIN: reset generated by reset pin
 - PMU_ExtWDT: WDT1 reset
 - PMU_SOFT: software reset
 - PMU_Wake: stop mode exit with reset
 - Reset_Type_3: peripheral reset (contains all resets)
 - Reset_Type_4: peripheral reset (without SOFT)
- Baud-rate generator:
 - $f_{BRUART1}$: baud-rate clock for UART1
 - $f_{BRUART2}$: baud-rate clock for UART2
 - $f_{BRMXCXPi}$: baud-rate clock for MXCXPi protocol controller

6 System control unit - digital modules (SCU-DM)

- Port control:
 - P0_POCONy.PDMx: driver strength control
 - P1_POCONy.PDMx: driver strength control
- MISC:
 - MODPISELx: mode selection registers for UART (source selection) and Timer (trigger or count selection)

6.3 Clock generation unit

The clock generation unit (CGU) provides a flexible clock generation for TLE9844QXC. During user program execution the frequency can be programmed for an optimal ratio between performance and power consumption. Therefore the power consumption can be adapted to the actual application state.

The CGU in the TLE9844QXC consists of one oscillator circuit (OSC_HP), a phase-locked loop (PLL) module including an internal oscillator (OSC_PLL) and a clock control unit (CCU). The CGU can convert a low-frequency input/external clock signal to a high-frequency internal clock.

The system clock f_{SYS} is generated out of the following selectable clocks:

- PLL clock output f_{PLL}
- Direct clock from oscillator OSC_HP f_{OSC}
- Direct output of internal oscillator f_{INTOSC}
- Low precision clock f_{LP_CLK} (HW-enabled for startup after reset and during power-down wake-up sequence)

The following sections describe the different parts of the CGU.

6.3.1 Low precision clock

The clock source LP_CLK is a low-precision RC oscillator (LP-OSC, see f_{LP_CLK}) that is enabled by hardware as an independent clock source for the TLE9844QXC startup after reset and during the power-down wake-up sequence. There is no user configuration possible on f_{LP_CLK} .

6.3.2 High precision oscillator circuit (OSC_HP)

The high precision oscillator circuit, designed to work with both an external crystal oscillator or an external stable clock source, consists of an inverting amplifier with XTAL1 as input, and XTAL2 as output.

Figure 10 shows the recommended external circuitries for both operating modes, external crystal mode and external input clock mode.

6.3.2.1 External input clock mode

When supplying the clock signal directly, not using an external crystal and bypassing the oscillator, the input frequency needs to be within the allowed range of P_3.1.6 (see electrical characteristics) if the PLL VCO part is used.

When using an external clock signal it must be connected to XTAL1. XTAL2 is left open (unconnected).

6.3.2.2 External crystal mode

When using an external crystal, its frequency can be within the allowed range of P_3.1.23 (see electrical characteristics). An external oscillator load circuitry must be used, connected to both pins, XTAL1 and XTAL2. It consists normally of the two load capacitances C1 and C2, for some crystals a series damping resistor might be necessary. The exact values and related operating range are dependent on the crystal and have to be determined and optimized together with the crystal vendor using the negative resistance method. As starting point for the evaluation, the following load cap values may be used:

6 System control unit - digital modules (SCU-DM)

Table 4 External CAP capacitors

Fundamental mode crystal frequency (approx., MHz)	Load caps C ₁ , C ₂ (pF)
4	33
8	18
12	12
16	10

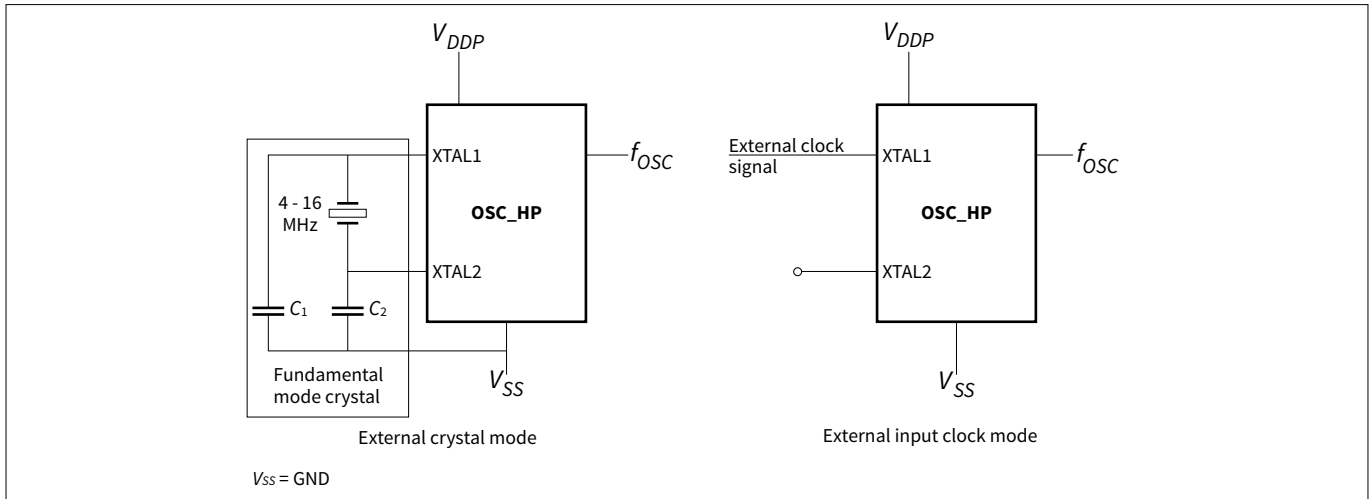

Figure 10 OSC_HP external circuit

6 System control unit - digital modules (SCU-DM)

6.3.3 Clock control unit

The clock control unit (CCU) receives the clock from the PLL f_{PLL} , the external input clock f_{OSC} , the internal input clock f_{INTOSC} , or the low-precision input clock f_{LP_CLK} . The system frequency is derived from one of these clock sources.

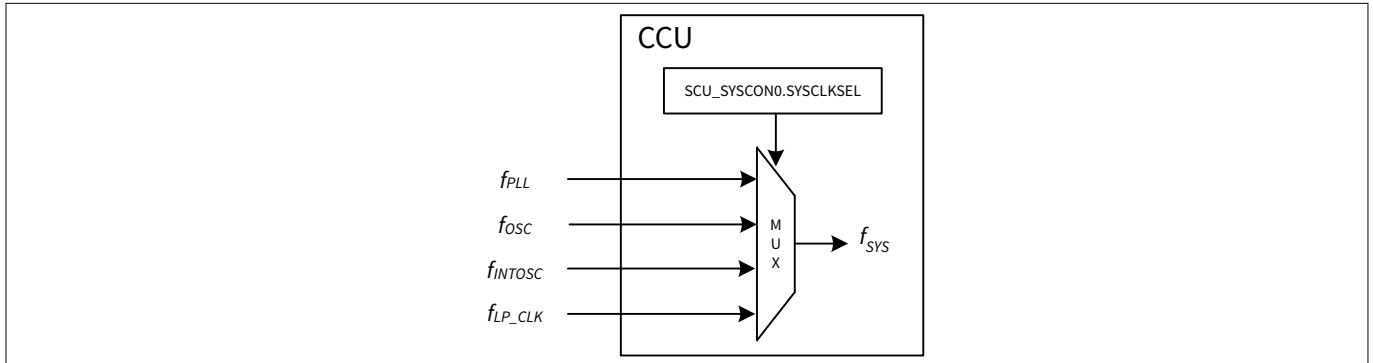

Figure 11 Clock inputs to clock control unit

The CCU generates all necessary clock signals within the microcontroller from the system clock. It consists of:

- Clock slow down circuitry
- Centralized enable/disable circuit for clock control

In normal running mode, the main module frequencies (synchronous unless otherwise stated) are as follows:

- System frequency, f_{SYS} = up to 25 MHz (measurement interface clock MI_CLK is derived from this clock)
- CPU clock (CCLK, SCLK) = up to 25 MHz (divide-down of NVM access clock)
- NVM access clock (NVMACCCLK) = up to 25 MHz
- Peripheral clock (PCLK, PCLK2, NVMCLK) = up to 25 MHz (equals CPU clock; must be same or higher)

Some peripherals are clocked by PCLK, others clocked by PCLK2 and the NVM is clocked by both NVMCLK and NVMACCCLK. During normal running mode, PCLK = PCLK2 = NVMCLK = CCLK. On wake-up from power-down mode, PCLK2 is restored similarly like NVMCLK, whereas PCLK is restored only after PLL is locked.

For optimized NVM access (read/write) with reduced wait state(s) and with respect to system requirements on CPU operational frequency, bit field NVMCLKFAC is provided for setting the frequency factor between the NVM access clock NVMACCCLK and the CPU clock CCLK.

For the slow down mode, the operating frequency is reduced using the slow down circuitry with clock divider setting at the bit field CLKREL. Bit field CLKREL is only effective when slow down mode is enabled via SFR bit PMCON0.SD bit. Note that the slow down setting of bit field CLKREL correspondingly reduces the NVMACCCLK clock. Slow down setting does not influence the erase and write cycles for the NVM.

Peripherals UART1, UART2, T2 and T21 are not influenced by CLKREL and either not by NVMCLKFAC, to allow functional LIN communication in slow down mode²⁾.

²⁾ The CXPI module is not suitable for slow down.

6 System control unit - digital modules (SCU-DM)

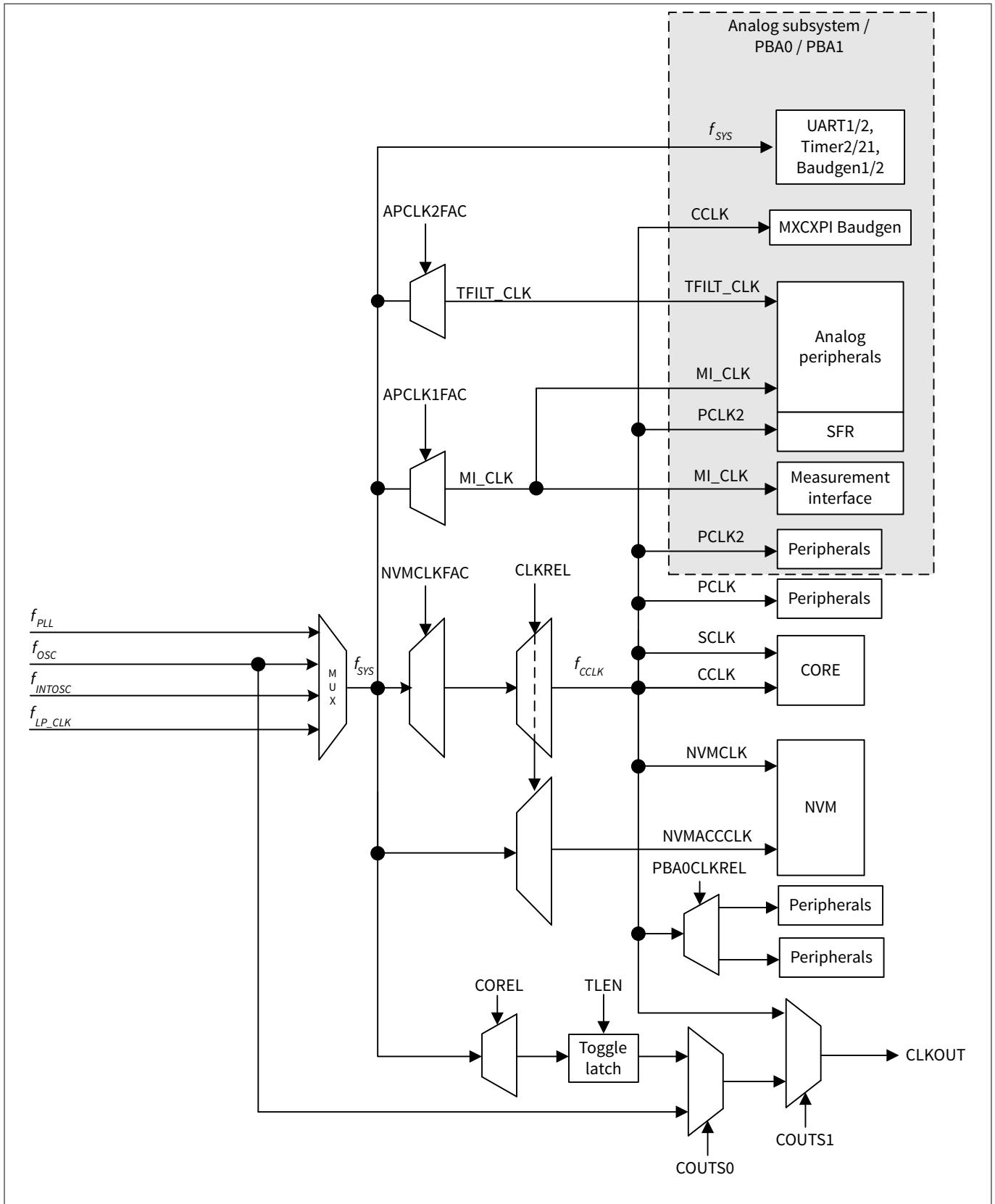

Figure 12 Clock generation from f_{SYS} ; CLKOUT generation

7 System control unit - power modules (SCU-PM)

7 System control unit - power modules (SCU-PM)

7.1 Description of the power modules system control unit

The system control unit of the power modules consists of the following submodules:

- Clock watchdog unit (CWU): Supervision of all power modules relevant clocks with NMI signaling
- Interrupt control unit (ICU): All system relevant interrupt flags and status flags
- Power control unit (PCU): Takes over control when device enters and exits sleep and stop mode
- External watchdog (WDT1): Independent system watchdog to monitor system activity

7.2 Introduction

7.2.1 Block diagram

The system control unit of the power modules consists of the submodules in the figure shown below:

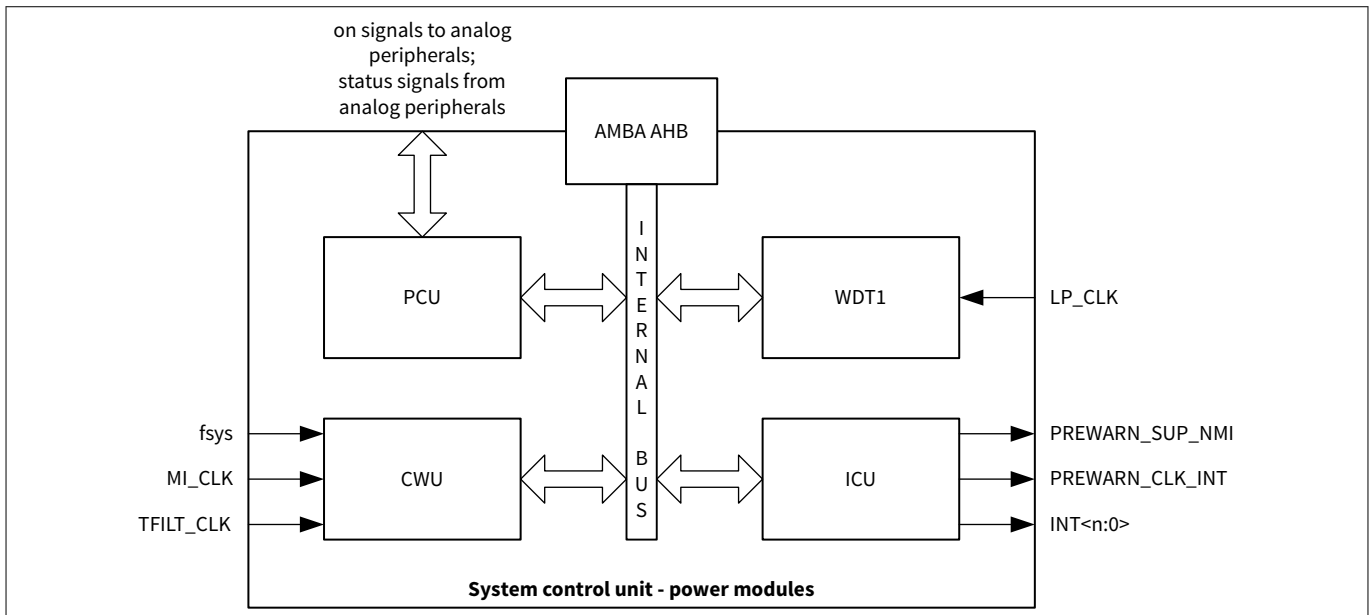

Figure 13 Block diagram of system control unit - power modules

IO description of SCU_PM

- CWU (clock watchdog unit)
 - check of f_{sys} = system frequency: output of PLL
 - check of MI_CLK = measurement interface clock (analog clock): derived out of f_{sys} by division factors 1/2/3/4
 - check of TFILT_CLK = clock used for digital filters: derived out of f_{sys} by configurable division factors
- ICU (interrupt control unit)
 - PREWARN_SUP_NMI = generation of pre-warn supply NMI
 - PREWARN_CLK_INT = generation of pre-warn clock watchdog NMI
 - INT = generation of MISC interrupts

8 Arm® Cortex® -M0 core

8.1 Features

The key features of the Arm® Cortex® -M0 implemented are listed below.

Processor core – a low gate count core, with low latency interrupt processing:

- Thumb® + Thumb-2® instruction set
- Banked stack pointer (SP) only
- Handler and thread modes
- Thumb and debug states
- Interruptible-continued instructions LDM/STM, push/pop for low interrupt latency
- Automatic processor state saving and restoration for low latency interrupt service routine (ISR) entry and exit
- Arm® architecture v6-M style
- Arm® v6 unaligned accesses
- SysTick (typical 1 ms)

Nested vectored interrupt controller (NVIC) closely integrated with the processor core to achieve low latency interrupt processing:

- External interrupts, configurable from 1 to 24
- 7 interrupt priority registers for levels from 0 up to 192 in steps of 64
- Dynamic re-prioritization of interrupts
- Priority grouping. This enables selection of preempting interrupt levels and non preempting interrupt levels
- Support for tail-chaining and late arrival of interrupts. This enables back-to-back interrupt processing without the overhead of state saving and restoration between interrupts
- Processor state automatically saved on interrupt entry, and restored on interrupt exit, with no instruction overhead

Bus interfaces

- Advanced high-performance bus-lite (AHB-Lite) interfaces

8 Arm® Cortex® -M0 core

8.2 Introduction

The Arm® Cortex® -M0 processor is a leading 32-bit processor and provides a high-performance and cost-optimized platform for a broad range of applications including microcontrollers, automotive body systems and industrial control systems. Like the other Arm® Cortex® -family processors, the Arm® Cortex® -M0 processor implements the Thumb® -2 instruction set architecture. With the optimized feature set the Arm® Cortex® -M0 delivers 32-bit performance in an application space that is usually associated with 8-bit and 16-bit microcontrollers.

8.2.1 Block diagram

The following figure shows the functional blocks of the Arm® Cortex® -M0.

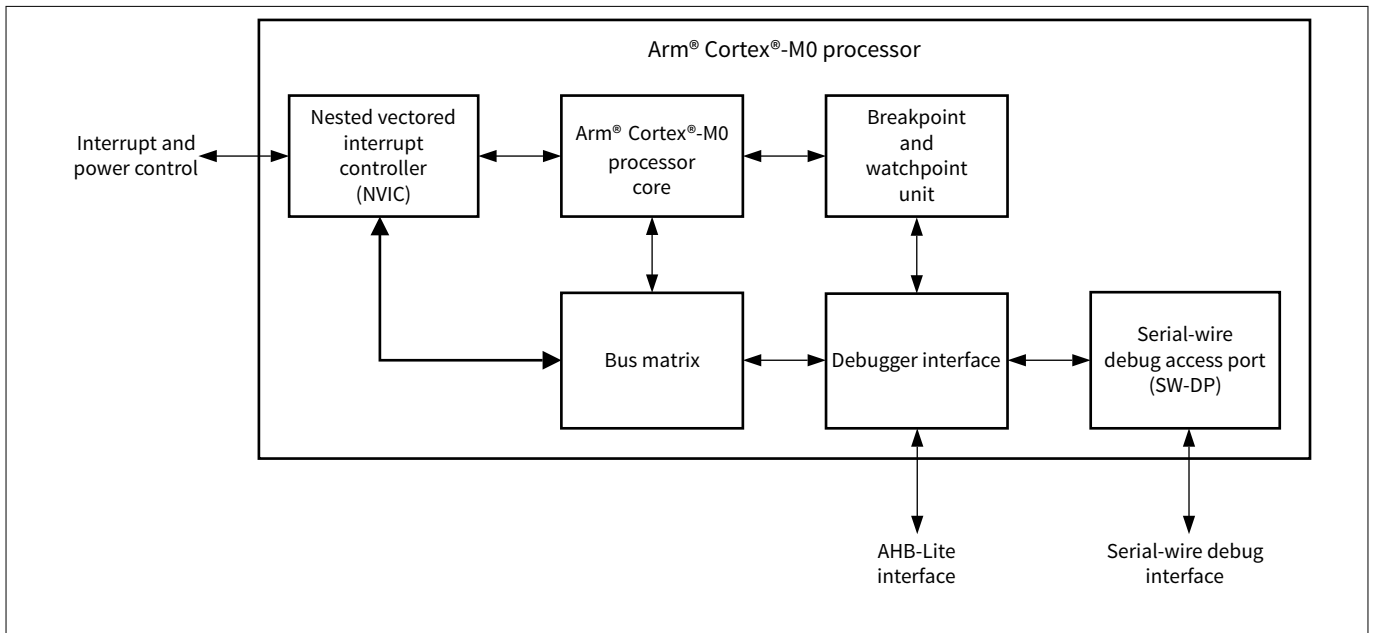

Figure 14 Arm® Cortex® -M0 block diagram

9 Address space organization

9 Address space organization

The embedded Arm® Cortex®-M0 MCU offers the following address space organization:

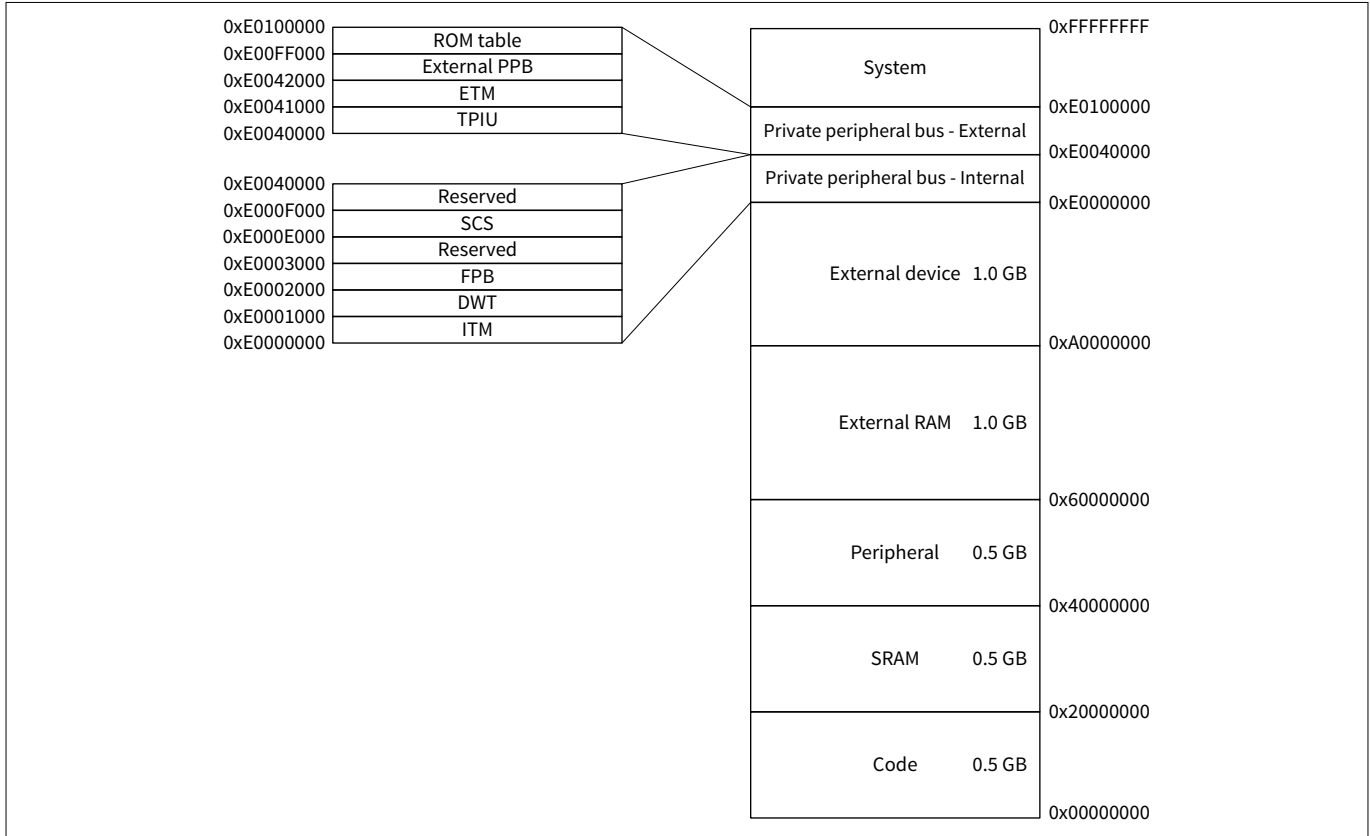

Figure 15 Original Arm® Cortex®-M0 memory map

The TLE9844QXC manipulates operands in the following memory spaces:

- 64 KB of flash memory in code space
- 24 KB boot ROM memory in code space (used for boot code and IP storage)
- 4 KB RAM memory in code space and data space (RAM can be read/written as program memory or external data memory)
- Special function registers (SFRs) in peripheral linear address space, up to 0.5 GB

The figure below shows the detailed address alignment of TLE9844QXC.

9 Address space organization

The on-chip memory modules available in the TLE9844QXC are:

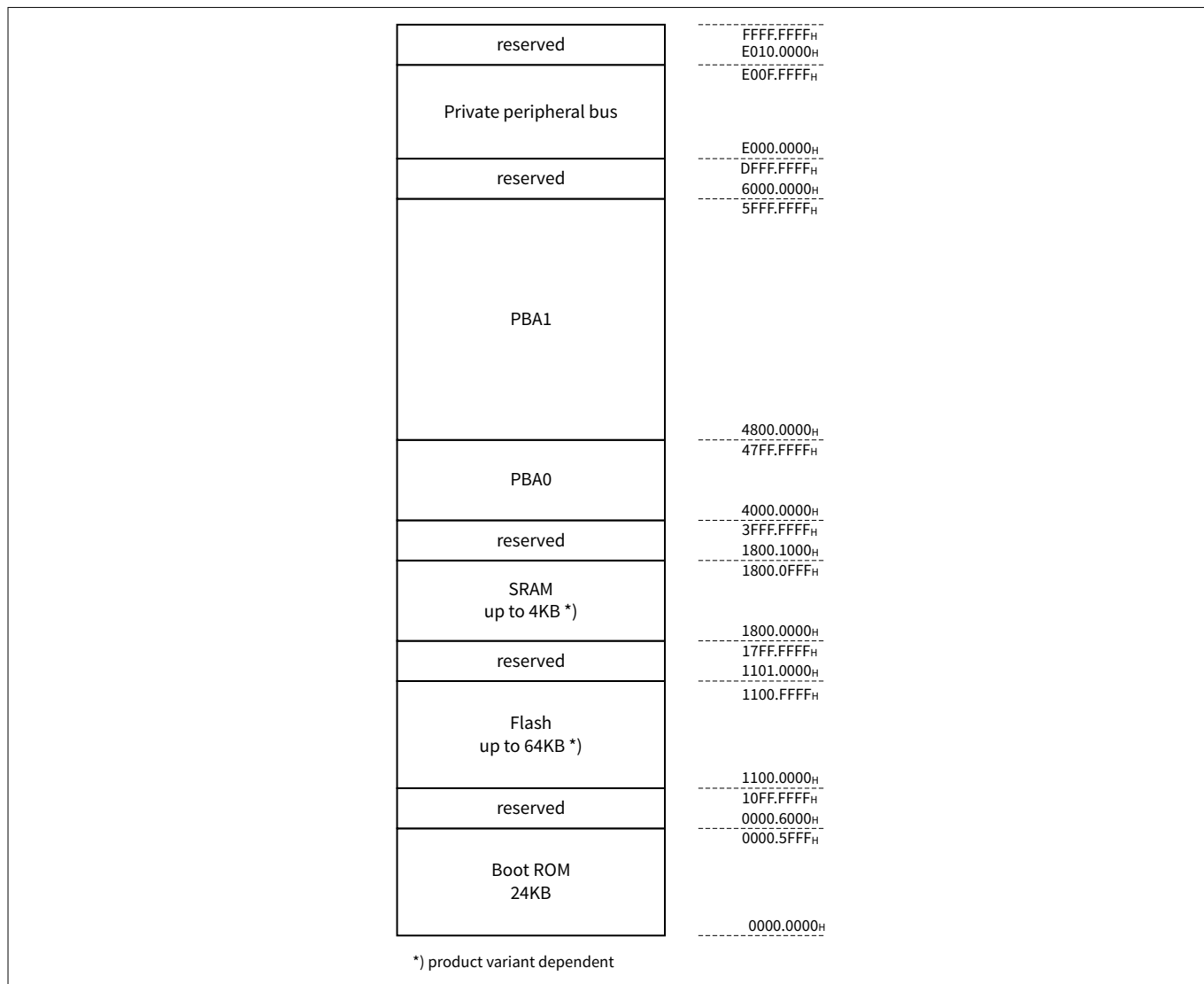

Figure 16 TLE9844QXC memory map

10 Memory control unit

10 Memory control unit

10.1 Features

- Provides memory access to ROM, RAM, NVM, config sector through AHB-Lite interface
- MBIST for RAM
- MBIST for ROM
- NVM configuration with special function registers through AHB-Lite interface
- Hardware memory protection logic

10.2 Introduction

10.2.1 Block diagram

The memory control unit is divided in the following submodules:

- NVM memory module (embedded flash memory)
- RAM memory module
- BootROM memory module
- Memory protection unit (MPU) module

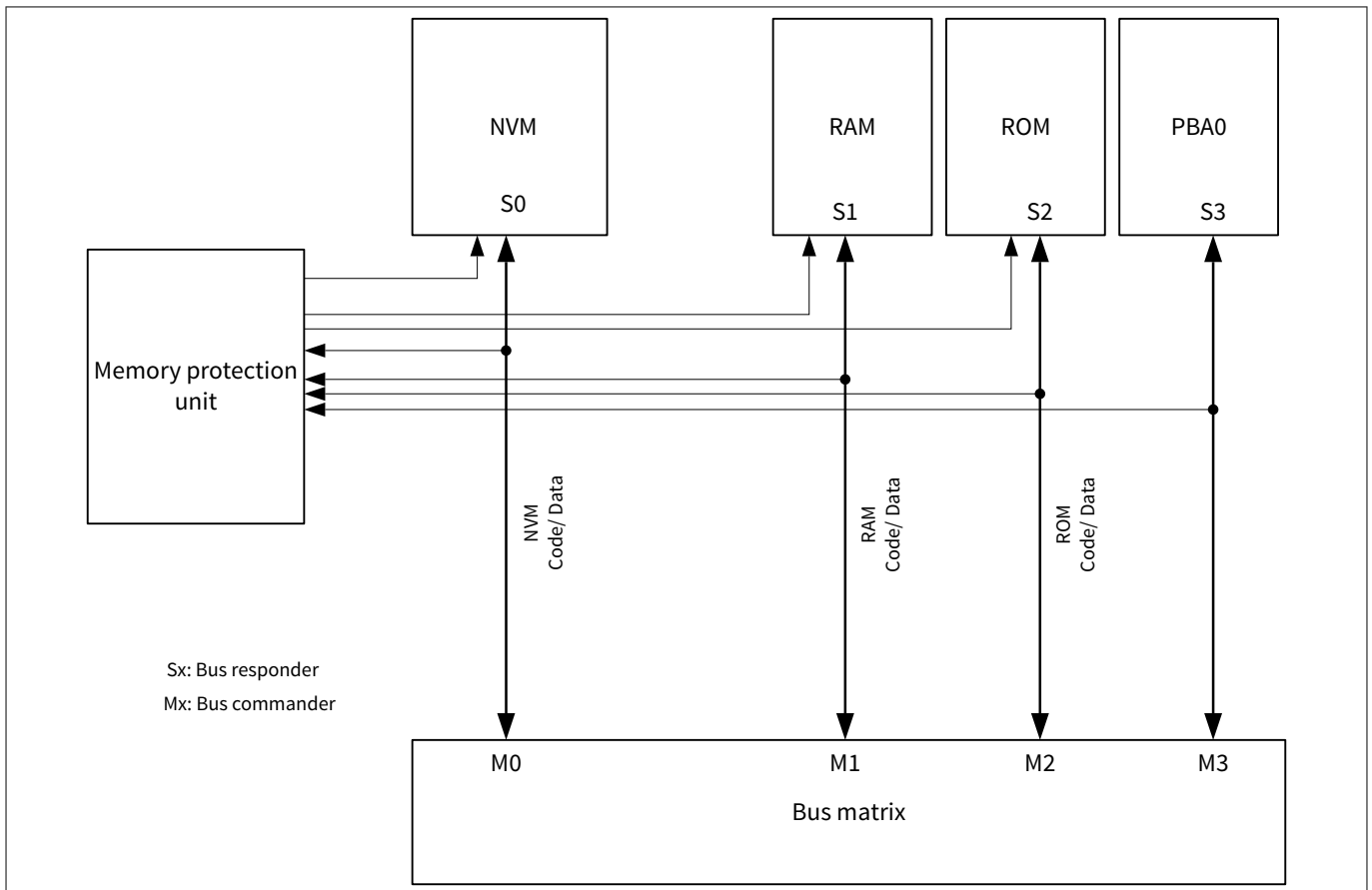

Figure 17 Memory control unit block view

Functional features for RAM

- 4 Kbytes RAM

10 Memory control unit

- Error correction code (ECC) for detection of single bit and double bit errors and dynamic correction of single bit errors
- Single byte access

11 NVM module (flash memory)

11 NVM module (flash memory)

The flash memory provides an embedded user-programmable non-volatile memory, allowing fast and reliable storage of user code and data.

Features

- In-system programming via LIN (flash mode) and SWD
- Error correction code (ECC) for detection of single bit and double bit errors and dynamic correction of single bit errors on data block (double words, 64 bit).
- Interrupt and signaling of double bit error by NMI, address of double bit error readable by FW API user routine.
- Possibility of checking single bit error occurrence by ROM routines
- Program width of 128 Byte (page)
- Minimum erase width of 128 Byte (page)
- Integrated hardware support for EEPROM emulation
- 8 Byte read access
- Physical read access time: typical 75 ns
- Code read access acceleration integrated; read buffer
- Page program time: typical 3 ms
- Programming time for 64 Kbyte via debug interface: < 1800 ms (typical)
- Page erase (128 Byte) and sector erase (4 Kbyte) time: typical 4 ms
- 3 separate keys for data area, program area and BSL area
- Password protection for three configurable program flash areas, three separate keys for data, program and BSL
- Option to protect read out via debug interface in application run mode. NVM protection mode available, which can be enabled/disabled with password
- Write/erase access to 100TP (e.g. option Bytes) is possible via the debug interface

Note: *The user has to ensure that no flash operations which change the content of the flash get interrupted at any time.*

The clock for the NVM is supplied with the system frequency f_{sys} . Integrated firmware routines are provided to ease NVM, and other operations including EEPROM emulation.

The TLE9844QXC NVM module provides physical implementation of the memory module as well as needed complementary features and interface towards the core.

The module provides proper access to the memory through 2 AHB-Lite interfaces: a 8-bit data interface for NVM internal register access and a 32-bit data interface for code/data access both multiplexed on Arm® Cortex®-M0 system bus.

The TLE9844QXC NVM module consists of the memory cell array and all the control circuits and registers needed to access the array itself. The 64 Kbyte data module is mapped in the Arm® Cortex®-M0 code address range 11000000_H - 1100FFFF_H while the dedicated SFRs are mapped in the Arm® Cortex®-M0 system address range 58004000_H - 58007FFF_H.

Access of NVM module is granted through the AMBA matrix block that forwards to the memory modules AHB-Lite interfaces the requests generated by the commanders according to the defined priority policy.

11 NVM module (flash memory)

11.1 Definitions

This section defines the nomenclature and some abbreviations. The used flash memory is a non-volatile memory (NVM) based on a floating gate one-transistor cell. It is called non-volatile because the memory content is kept when the memory power supply is shut off.

11.1.1 General definitions

Logical and physical states

Erasing

The erased state of a cell is '1'. Forcing an NVM cell to this state is called erasing. Erasing is possible with a granularity of a page (see below).

Writing

The written state of a cell is '0'. Forcing an NVM cell to this state is called writing. Each bit can be individually written.

Programming

The combination of erasing and writing is called 'programming'. Programming often means also writing a previously erased page.

The wording 'write' or 'writing' are also used for accessing special function registers and the assembly buffer. The meaning depends therefore on the context.

The above listed processes have certain limitations:

Retention: This is the time during which the data of a flash cell can be read reliably. The retention time is a statistical figure that depends on the operating conditions of the flash array (temperature profile) and the accesses to the flash array. With an increasing number of program/erase cycles (see endurance) the retention is lowered. Drain and gate disturbs decrease data retention as well.

Endurance: As described above, the data retention is reduced with an increasing number of program/erase cycles. A flash cell incurs one cycle whenever its page or sector is erased. This number is called "endurance". As said for the retention, it is a statistical figure that depend on operating conditions and the use of the flash cells and on the required quality level.

Drain disturb: Because of using a so called "one-transistor" flash cell each program access disturbs all pages of the same sector slightly. Over long these "drain disturbs" make 0 and 1 values indistinguishable and thus provoke read errors. This effect is again interrelated with the retention. A cell that incurred a high number of drain disturbs will have a lower retention. The physical sectors of the flash array are isolated from each other. So pages of a different sector do not incur a drain disturb. This effect must be therefore considered when the page erase feature is used or when re-programming a ready programmed page (implicitly causing an erase of the page before writing the new data).

11 NVM module (flash memory)

Data portions

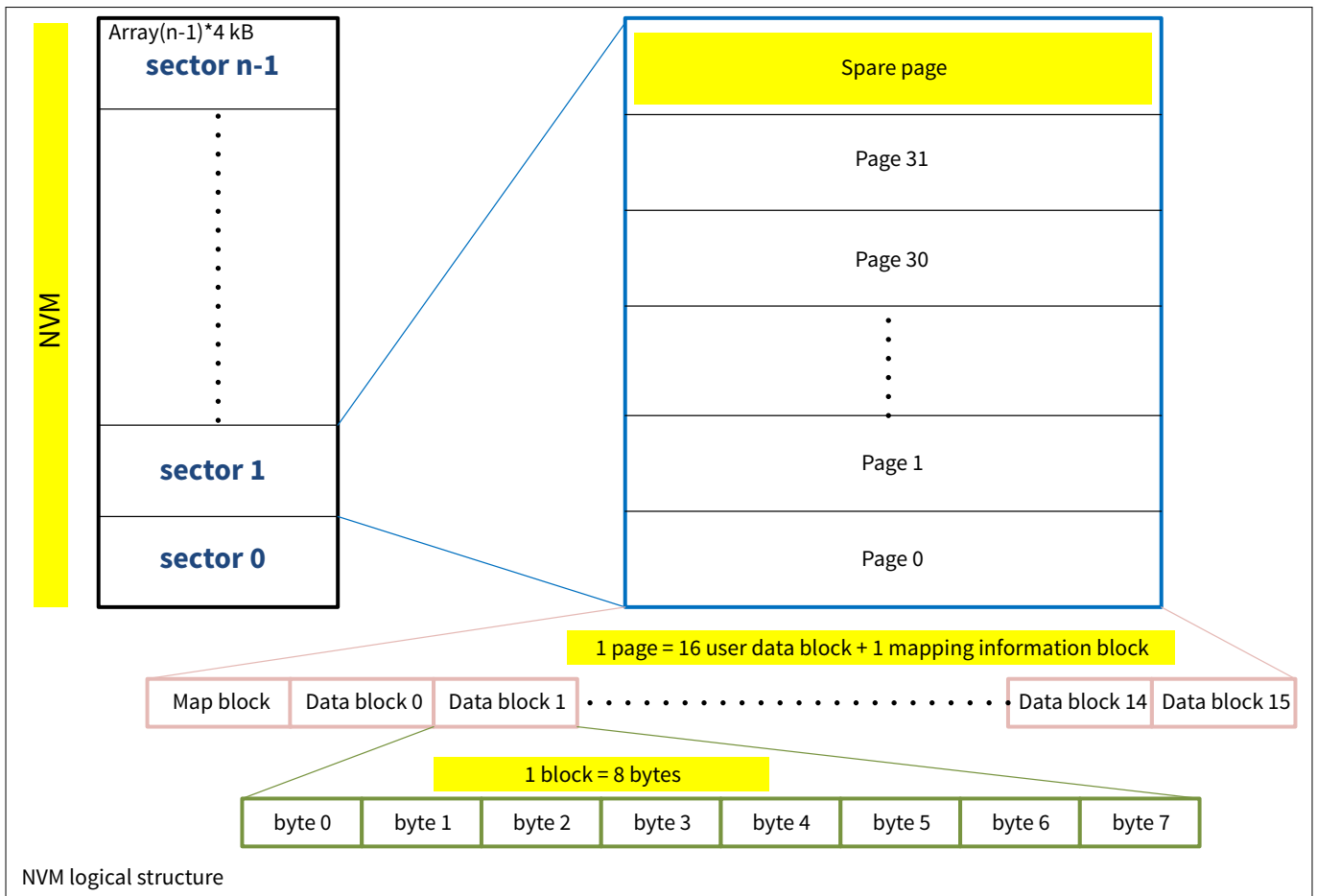

Figure 18 **Logical structure of the NVM core**

Doubleword

A doubleword consists of 64 bits. A doubleword represents the data size that is read from or written to the NVM core module within one access cycle.

Block

A block consists of one doubleword and its associated ECC data (64 bit data and 8 bit ECC). A block represents the smallest data portion that can be changed in the assembly buffer. Since the ECC protects 64 bits, when a byte is written to the assembly buffer automatically an NVM internal read of the complete block is triggered, the byte and the ECC are updated and the complete block is written back to the assembly buffer.

Mapblock

A map block consists of a module specific number of ECC-protected bits that hold the necessary information to map a physical page to a logical page.

Page

A page consists of 16 blocks and one map block.

Spare page

A spare page is an additional page in a sector used in each programming routine to allow tearing-safe programming.

Sector

A sector consists of 32 logical and 33 physical pages.

12 Interrupt system

12 Interrupt system

12.1 Features

- Up to 24 interrupt nodes for on-chip peripherals
- Up to 8 NMI nodes for critical system events
- Maximum flexibility for all 24 interrupt nodes

12.2 Introduction

12.2.1 Overview

The TLE9844QXC supports 24 interrupt vectors with 4 priority levels. 22 of these interrupt vectors are assigned to the on-chip peripherals: GPT12, SSC1, SSC2, CCU6, MXCXPI, low-side switch, high-side switch and A/D converter are each assigned to one dedicated interrupt vector; while UART1 and Timer2 or UART2, external interrupt 2 and Timer21 share interrupt vectors. Two vectors are dedicated for external interrupt 0 and 1.

Table 5 Interrupt vector table

Service request	Node ID	Description
GPT1	0	GPT1 interrupt
GPT2	1	GPT2 interrupt
MU	2	MU interrupt / ADC2, VBG interrupt
ADC1	3	ADC1 interrupt
CCU0	4	CCU6 node 0 interrupt
CCU1	5	CCU6 node 1 interrupt
CCU2	6	CCU6 node 2 interrupt
CCU3	7	CCU6 node 3 interrupt
SSC1	8	SSC1 interrupt (receive, transmit, error)
SSC2	9	SSC2 interrupt (receive, transmit, error)
UART1	10	UART1 (ASC-LIN) interrupt (receive, transmit), t2, linsync1, LIN
UART2	11	UART2 interrupt (receive, transmit), t21, external interrupt (EINT2)
EXINT0	12	External interrupt (EINT0)
EXINT1	13	External interrupt (EINT1)
WAKEUP	14	Wake-up interrupt (generated by a wake-up event)
MXCXPI	15	MXCXPI protocol controller interrupt
rfu	16	Reserved for future use
LS1	17	Low-side 1 interrupt
LS2	18	Low-side 2 interrupt
HS1	19	High-side 1 interrupt
rfu	20	Reserved for future use

(table continues...)

12 Interrupt system

Table 5 (continued) Interrupt vector table

Service request	Node ID	Description
rfu	21	Reserved for future use
MONx	22	MONx interrupt
Port 2.x	23	Port 2.x - DPP1

Table 6 NMI interrupt table

Service request	Node	Description
PLL NMI	NMI	PLL loss-of-lock
NVM operation complete NMI	NMI	NVM operation complete
Overtemperature NMI	NMI	System overtemperature
Oscillator watchdog NMI	NMI	Oscillator watchdog and MI_CLK watchdog timer overflow
NVM Map error NMI	NMI	NVM map error
ECC error NMI	NMI	RAM/NVM uncorrectable ECC error
Supply prewarning NMI	NMI	Supply prewarning

13 Watchdog timer (WDT1)

13.1 Features

In active mode, the WDT1 acts as a windowed watchdog timer, which provides a highly reliable and safe way to recover from software or hardware failures.

The WDT1 is always enabled in Active mode. In Sleep mode, Stop mode and Debug mode the WDT1 is disabled.

Functional features

- Watchdog timer is operating with a from the system clock (f_{SYS}) independent clock source (f_{LP_CLK})
- Windowed watchdog timer with programmable timing (16, 32, 48, ..., 1008 ms period) in Active mode
- Long open window (200 ms) after power-up, reset, wake-up
- Short open window (30 ms) to facilitate flash programming
- System safety shutdown to sleep mode after 5 missed WDT1 services
- Watchdog is disabled in Debug mode
- Watchdog cannot be deactivated in Normal mode
- Watchdog reset is stored in reset status register

13 Watchdog timer (WDT1)

13.2 Introduction

The behavior of the watchdog timer in Active mode is depicted in Figure 19.

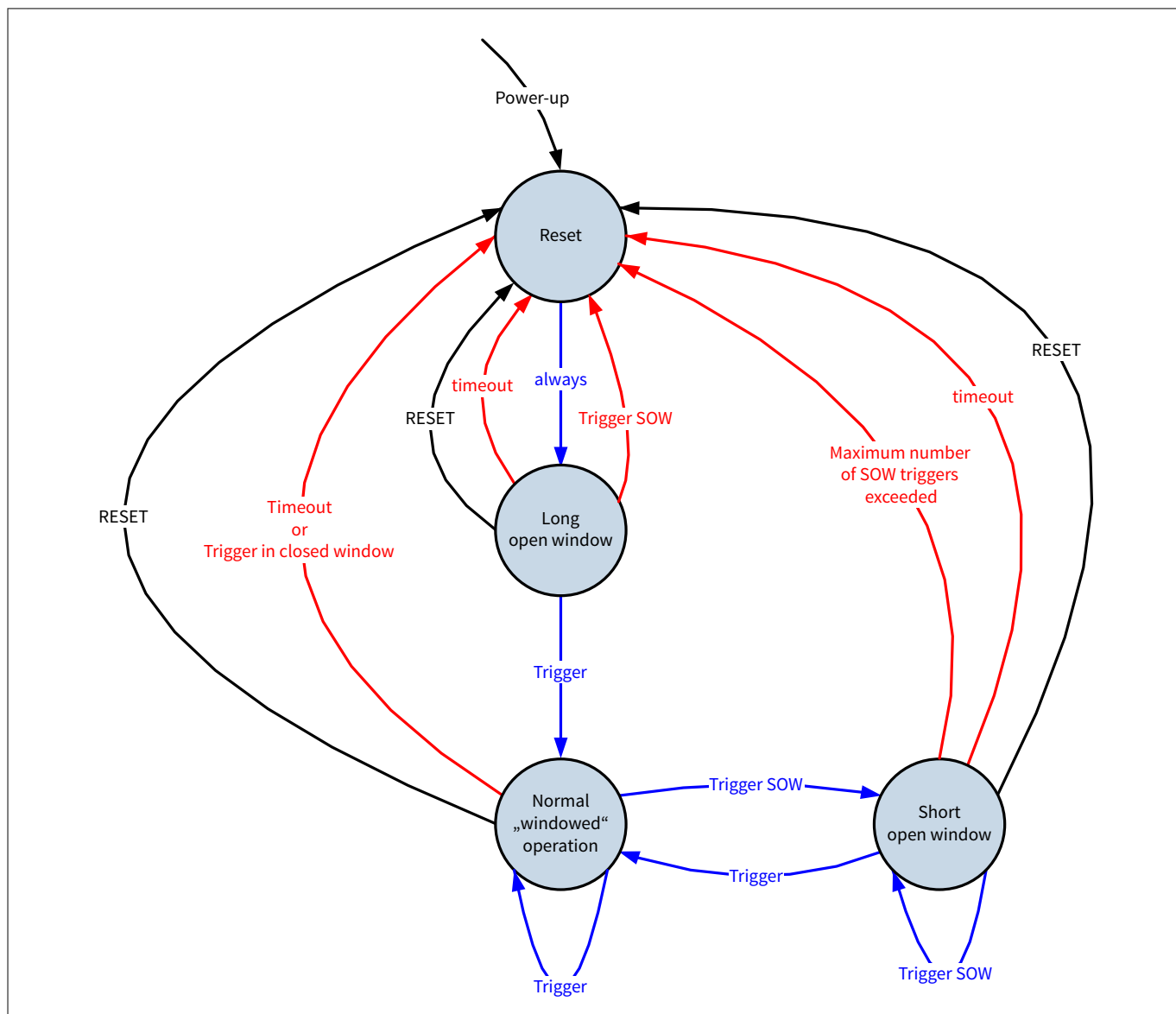

Figure 19 Watchdog timer behavior

14 GPIO ports and peripheral I/O

The TLE9844QXC has 18 port pins organized into three parallel ports: port 0 (P0), port 1 (P1) and port 2 (P2). Each port pin has a pair of internal pull-up and pull-down devices that can be individually enabled or disabled. P0 and P1 are bidirectional and can be used as general purpose input/output (GPIO) or to perform alternate input/output functions for the on-chip peripherals. When configured as an output, the open drain mode can be selected. On port 2 (P2) analog inputs are shared with general purpose input.

14.1 Features

- 10 GPIOs (P0.x & P1.x), 6 analog inputs (P2.x) and two additional analog inputs shared with an XTAL feature (P2.4, P2.5).
- Strong pull-up at reset pin and Hall inputs (except P2.x)

Bidirectional port features (P0, P1)

- Configurable pin direction
- Configurable pull-up/pull-down devices
- Configurable open drain mode
- Configurable drive strength
- Transfer of data through digital inputs and outputs (general purpose I/O)
- Alternate input/output for on-chip peripherals

Analog port features (P2)

- Configurable pull-up/pull-down devices
- Transfer of data through digital inputs
- Alternate inputs for on-chip peripherals

14 GPIO ports and peripheral I/O

14.2 Introduction

14.2.1 Port 0 and port 1

Figure 20 shows the block diagram of an TLE9844QXC bidirectional port pin. Each port pin is equipped with a number of control and data bits, thus enabling very flexible usage of the pin.

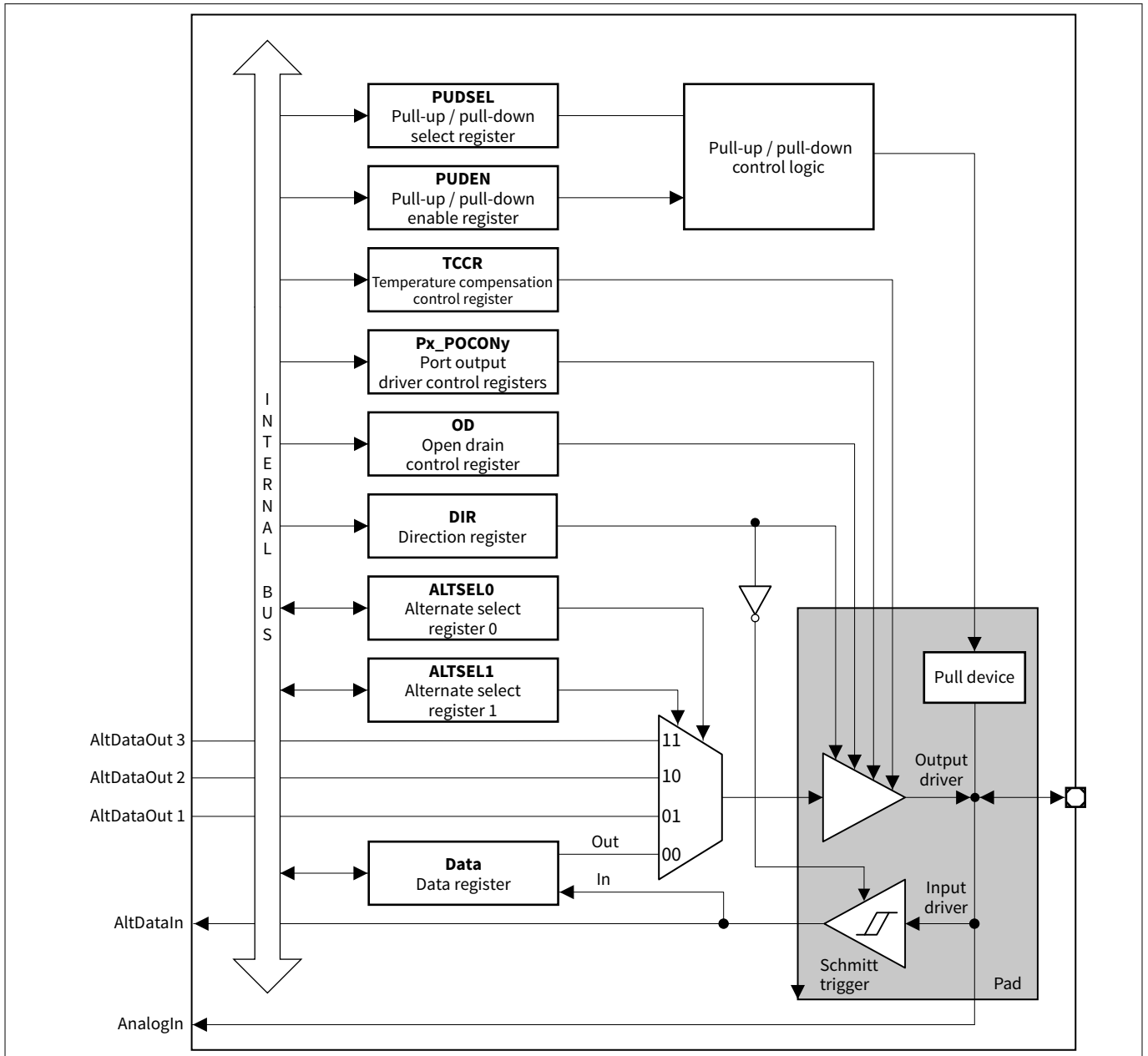

Figure 20 General structure of bidirectional port

14 GPIO ports and peripheral I/O

14.2.2 Port 2

Figure 21 shows the structure of an input-only port pin. Each P2 pin can only function in input mode. Register P2_DIR is provided to enable or disable the input driver. When the input driver is enabled, the actual voltage level present at the port pin is translated into a logic 0 or 1 via a Schmitt-Trigger device and can be read via the register P2_DATA. Each pin can also be programmed to activate an internal weak pull-up or pull-down device. Register P2_PUDSEL selects whether a pull-up or the pull-down device is activated while register P2_PUDEN enables or disables the pull device. The analog input (AnalogIn) bypasses the digital circuitry and Schmitt-Trigger device for direct feed-through to the ADC input channel.

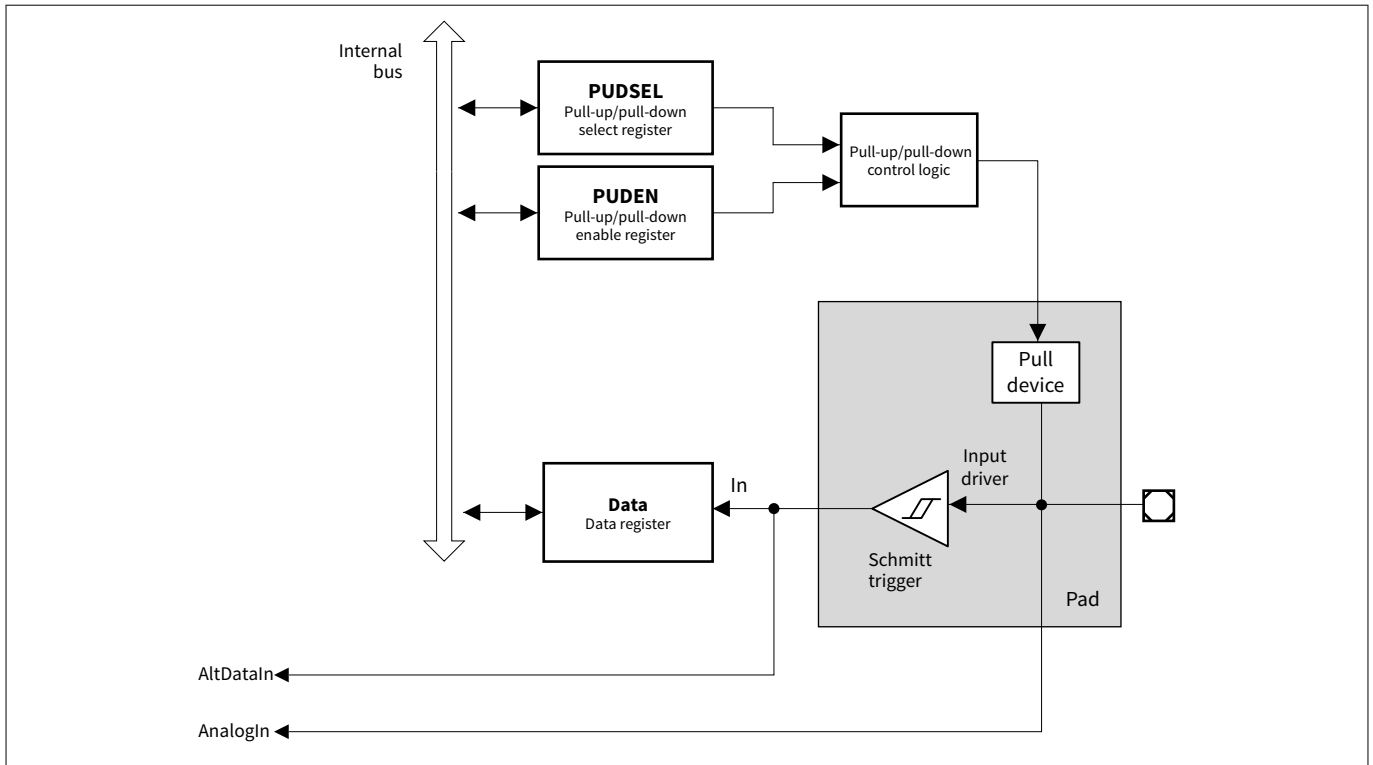

Figure 21 General structure of input port

14 GPIO ports and peripheral I/O

14.3 Port implementation details

14.3.1 Port 0

14.3.1.1 Port 0 functions

Port 0 alternate function mapping according [Table 7](#)

Table 7 Port 0 input/output functions

Port pin	Input/output	Select	Connected signal(s)	From/to module	
P0.0	Input	GPI	P0_DATA.P0		
		INP1	T12HR_0	CCU6	
		INP2	T4INA	GPT12	
		INP3	T2_0	Timer 2	
		INP4	SWD_CLK	SWD	
		INP5	EXINT2_3	SCU	
	Output	GPO	P0_DATA.P0		
		ALT1	T3OUT_0	GPT12	
		ALT2	EXF21_0	Timer 21	
		ALT3	UART2_RXDO	UART2	
	P0.1	Input	GPI	P0_DATA.P1	
			INP1	T13HR_0	CCU6
			INP2	UART1_RXD, RXDPWM	UART1, MXCXPI
INP3			T2EX_1	Timer 2	
INP4			T21_0	Timer 21	
INP5			EXINT0_3	SCU	
INP6			T4INC	GPT12	
INP7			CAPINA	GPT12	
INP8			SSC12_S_SCK	SSC1/2	
INP9		CC62_0	CCU6		
Output		GPO	P0_DATA.P1		
		ALT1	T6OUT_0	GPT12	
		ALT2	CC62_0	CCU6	
		ALT3	SSC12_M_SCK	SSC1/2	
P0.2	Input	GPI	P0_DATA.P2		
		INP1	T2EUDA	GPT12	
		INP2	CTRAP_0	CCU6	

(table continues...)

14 GPIO ports and peripheral I/O

Table 7 (continued) Port 0 input/output functions

Port pin	Input/output	Select	Connected signal(s)	From/to module		
		INP3	SSC12_M_CRRT	SSC1/2		
		INP4	T21EX_0	Timer 21		
		INP5	EXINT1_3	SCU		
	Output	GPO	P0_DATA.P2			
		ALT1	SSC12_S_CRRT	SSC1/2		
		ALT2	UART1_TXD, TXDPWM	UART1, MXCXPI		
		ALT3	EXF2_0	Timer 2		
	P0.3	Input	GPI	P0_DATA.P3		
			INP1	SSC1_S_SCK	SSC1	
			INP2	T4EUDA	GPT12	
INP3			CAPINB	GPT12		
INP4			EXINT1_2	SCU		
INP5			T3EUDD	GPT12		
INP6			CCPOS0_1	CCU6		
Output		GPO	P0_DATA.P3			
		ALT1	SSC1_M_SCK	SSC1		
		ALT2	T6OFL	GPT12		
		ALT3	T6OUT_1	GPT12		
		P0.4	Input	GPI	P0_DATA.P4	
				INP1	SSC1_S_CTRR	SSC1
				INP2	CC60_0	CCU6
INP3	T21_2			Timer 21		
INP4	EXINT2_2			SCU		
INP5	T3EUDA			GPT12		
INP6	CCPOS1_1			CCU6		
Output	GPO		P0_DATA.P4			
	ALT1		SSC1_M_CTRR	SSC1		
	ALT2		CC60_0	CCU6		
	ALT3	CLKOUT_0	SCU			
P0.5	Input	GPI	P0_DATA.P5			
		INP1	SSC1_M_CRRT	SSC1		
		INP2	EXINT0_0	SCU		
		INP3	T21EX_2	Timer 21		

(table continues...)

Table 7 (continued) Port 0 input/output functions

Port pin	Input/output	Select	Connected signal(s)	From/to module
		INP4	T5INA	GPT12
		INP5	CCPOS2_1	CCU6
	Output	GPO	P0_DATA.P5	
		ALT1	SSC1_S_CRRT	SSC1
		ALT2	COOUT60_0	CCU6
		ALT3	LIN_RXD	TRX

14 GPIO ports and peripheral I/O

14.3.2 Port 1

14.3.2.1 Port 1 functions

Port 1 alternate function mapping according [Table 8](#)

Table 8 Port 1 input/output functions

Port pin	Input/output	Select	Connected signal(s)	From/to module
P1.0	Input	GPI	P1_DATA.P0	
		INP1	T3INC	GPT12
		INP2	CC61_0	CCU6
		INP3	SSC2_S_SCK	SSC2
		INP4	T4EUDB	GPT12
	Output	GPO	P1_DATA.P0	
		ALT1	SSC2_M_SCK	SSC2
		ALT2	CC61_0	CCU6
ALT3		UART2_TXD	UART2	
P1.1	Input	GPI	P1_DATA.P1	
		INP1	T6EUUDA	GPT12
		INP2	T5INB	GPT12
		INP3	T3EUDC	GPT12
		INP4	SSC2_S_CTRR	SSC2
		INP5	T21EX_3	Timer 21
		INP6	UART2_RXD	UART2
	Output	GPO	P1_DATA.P1	
		ALT1	SSC2_M_CTRR	SSC2
		ALT2	COUT61_0	CCU6
ALT3		EXF21_1	Timer 21	
P1.2	Input	GPI	P1_DATA.P2	
		INP1	EXINT0_1	SCU
		INP2	T21_1	Timer 21
		INP3	T2INA	GPT12
		INP4	SSC2_M_CRRT	SSC2
		INP5	CCPOS2_2	CCU6
	Output	GPO	P1_DATA.P2	
		ALT1	SSC2_S_CRRT	SSC2
ALT2		COUT63_0	CCU6	

(table continues...)

14 GPIO ports and peripheral I/O

Table 8 (continued) Port 1 input/output functions

Port pin	Input/output	Select	Connected signal(s)	From/to module
		ALT3	T3OUT_1	GPT12
P1.4	Input	GPI	P1_DATA.P4	
		INP1	EXINT2_1	SCU
		INP2	T21EX_1	Timer 21
		INP3	T2INB	GPT12
		INP4	T5EUDA	GPT12
		INP5	SSC12_S_CTRR	SSC1/2
		INP6	CCPOS1_2	CCU6
	Output	GPO	P1_DATA.P4	
		ALT1	CLKOUT_1	SCU
		ALT2	COOUT62_0	CCU6
		ALT3	SSC12_M_CTRR	SSC1/2

14 GPIO ports and peripheral I/O

14.3.3 Port 2

14.3.3.1 Port 2 functions

Port 2 alternate function mapping according [Table 9](#)

Table 9 Port 2 input functions

Port pin	Input/output	Select	Connected signal(s)	From/to module
P2.0	Input	GPI	P2_DATA.P0	
		INP1	EXINT1_1	SCU
		INP2	CCPOS0_2	CCU6
		INP3	T5EUDB	GPT12
		ANALOG	AN0	ADC
P2.1	Input	GPI	P2_DATA.P1	
		INP1	CCPOS0_0	CCU6
		INP2	EXINT1_0	SCU
		INP3	T12HR_1	CCU6
		INP4	CC61_1	CCU6
		ANALOG	AN1	ADC
P2.2	Input	GPI	P2_DATA.P2	
		INP1	T6EUDB	GPT12
		INP2	T2EX_0	Timer 2
		INP3	T12HR_2	CCU6
		ANALOG	AN2	ADC
P2.3	Input	GPI	P2_DATA.P3	
		INP1	CCPOS1_0	CCU6
		INP2	EXINT0_2	SCU
		INP3	CTRAP_1	CCU6
		INP4	T3IND	GPT12
		INP5	CC60_1	CCU6
		ANALOG	AN3	ADC
P2.4	Input	GPI	P2_DATA.P4	
		INP1	T2EUDB	GPT12
		INP2	T2_2	Timer 2
		INP3	T2EX_2	Timer 2
		INP4	CCPOS0_3	CCU6
		INP5	CTRAP_2	CCU6

(table continues...)

14 GPIO ports and peripheral I/O

Table 9 (continued) Port 2 input functions

Port pin	Input/output	Select	Connected signal(s)	From/to module
		IN	XTAL (in) ¹⁾	XTAL
P2.5	Input / Output	GPI	P2_DATA.P5	
		INP1	T3EUDB	GPT12
		INP2	T4EUDC	GPT12
		INP3	T2_1	Timer 2
		INP4	LIN_TXD, CXPI_TXD	TRX, MXCXPI
		INP5	CCPOS1_3	CCU6
		OUT	XTAL (out) ¹⁾	XTAL
P2.6	Input	GPI	P2_DATA.P6	
		INP1	T4EUDD	GPT12
		INP2	T2EX_3	Timer 2
		INP3	CCPOS2_3	CCU6
		INP4	T13HR_2	CCU6
		ANALOG	AN6	ADC
P2.7	Input	GPI	P2_DATA.P7	
		INP1	CCPOS2_0	CCU6
		INP2	EXINT2_0	SCU
		INP3	T13HR_1	CCU6
		INP4	CC62_1	CCU6
		ANALOG	AN7	ADC

1) Configurable by user.

15 General purpose timer units (GPT12)

15 General purpose timer units (GPT12)

15.1 Features

15.1.1 Features block GPT1

The following list summarizes the supported features:

- $f_{GPT}/4$ maximum resolution
- 3 independent timers/counters
- Timers/counters can be concatenated
- 4 operating modes:
 - Timer mode
 - Gated timer mode
 - Counter mode
 - Incremental interface mode
- Reload and capture functionality
- Shared interrupt: node 0

15.1.2 Features block GPT2

The following list summarizes the supported features:

- $f_{GPT}/2$ maximum resolution
- 2 independent timers/counters
- Timers/counters can be concatenated
- 3 operating modes:
 - Timer mode
 - Gated timer mode
 - Counter mode
- Extended capture/reload functions via 16-bit capture/reload register CAPREL
- Shared interrupt: node 1

15.2 Introduction

The general purpose timer unit blocks GPT1 and GPT2 have very flexible multifunctional timer structures which may be used for timing, event counting, pulse width measurement, pulse generation, frequency multiplication, and other purposes.

They incorporate five 16-bit timers that are grouped into the two timer blocks GPT1 and GPT2. Each timer in each block may operate independently in a number of different modes such as gated timer or counter mode, or may be concatenated with another timer of the same block.

Each block has alternate input/output functions and specific interrupts associated with it. Input signals can be selected from several sources by register PISEL.

The GPT module is clocked with clock f_{GPT} . f_{GPT} is a clock derived from f_{SYS} .

15 General purpose timer units (GPT12)

15.2.1 Block diagram GPT1

Block GPT1 contains three timers/counters: The core timer T3 and the two auxiliary timers T2 and T4. The maximum resolution is $f_{GPT}/4$. The auxiliary timers of GPT1 may optionally be configured as reload or capture registers for the core timer.

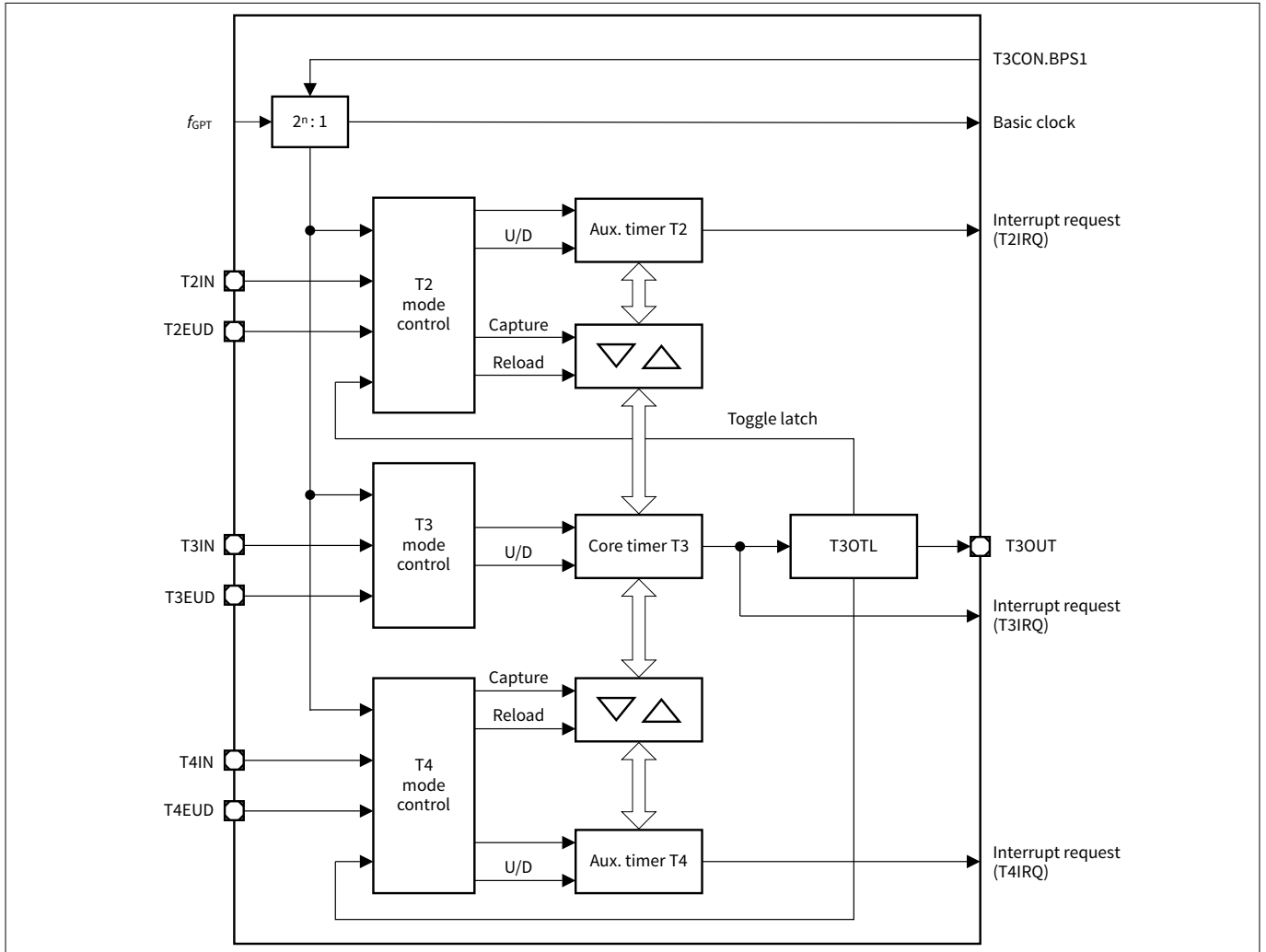

Figure 22 GPT1 block diagram (n = 2 ... 5)

15 General purpose timer units (GPT12)

15.2.2 Block diagram GPT2

Block GPT2 contains two timers/counters: The core timer T6 and the auxiliary timer T5. The maximum resolution is $f_{GPT}/2$. An additional capture/reload register supports capture and reload operation with extended functionality.

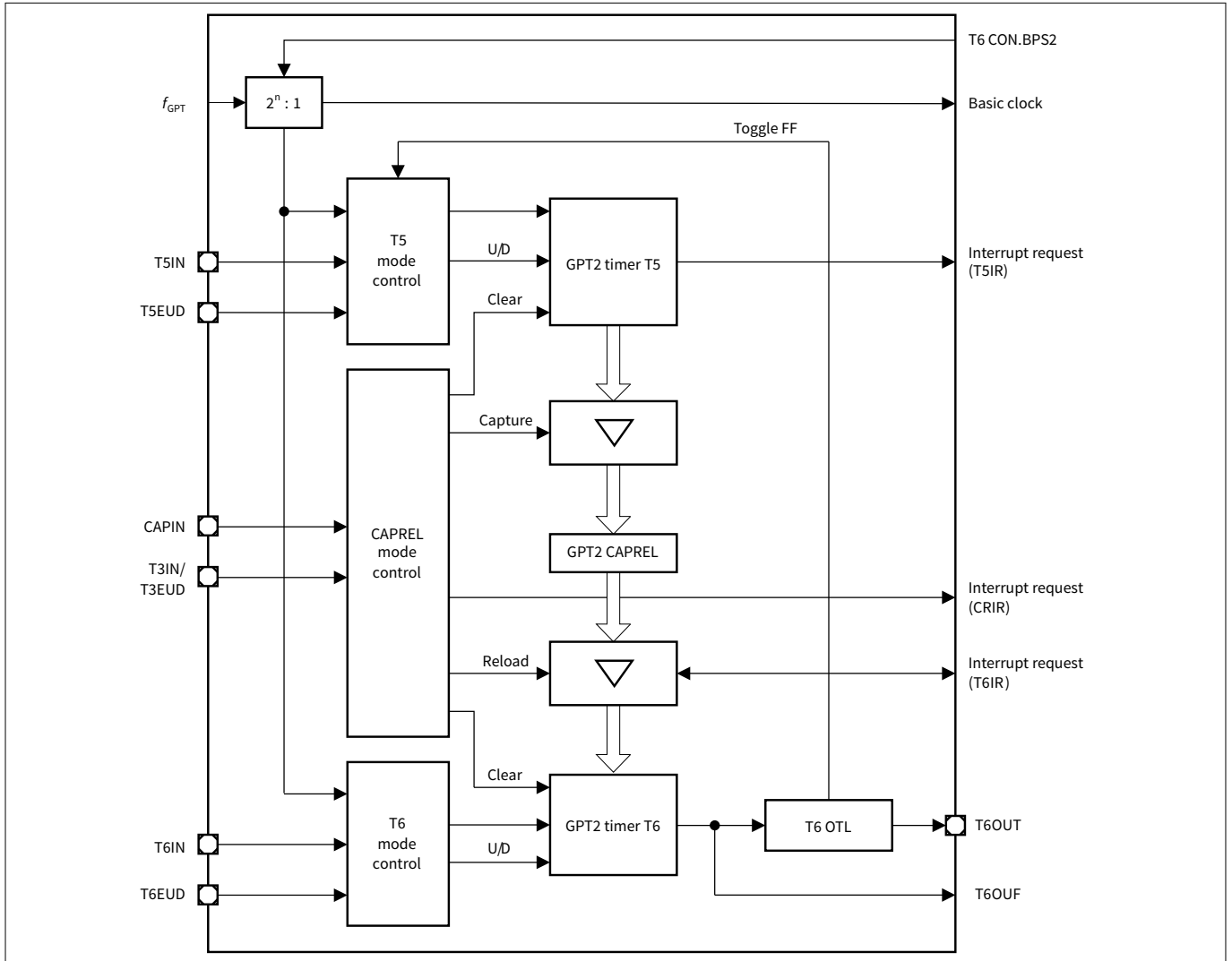

Figure 23 GPT2 block diagram (n = 1 ... 4)

16 Timer2 and Timer21

16.1 Features

- 16-bit auto-reload mode
 - selectable up or down counting
- One channel 16-bit capture mode
- Baud-rate generator for U(S)ART

16.2 Introduction

Two functionally identical timers are implemented: Timer2 and Timer21. The description refers to Timer2 only, but applies to Timer21 as well.

The timer modules are general purpose 16-bit timer. Timer2 can function as a timer or counter in each of its modes. As a timer, it counts with an input clock of $f_{sys}/12$ (if prescaler is disabled). As a counter, Timer2 counts 1-to-0 transitions on pin T2. In the counter mode, the maximum resolution for the count is $f_{sys}/24$ (if prescaler is disabled).

16.2.1 Timer2 and Timer21 modes overview

Table 10 Timer2 and Timer21 modes

Mode	Description
Auto-reload	Up/down count disabled <ul style="list-style-type: none"> • Count up only • Start counting from 16-bit reload value, overflow at FFFF_H • Reload event configurable for trigger by overflow condition only, or by negative/positive edge at input pin T2EX as well • Programmable reload value in register RC2 • Interrupt is generated with reload events
Auto-reload	Up/down count enabled <ul style="list-style-type: none"> • Count up or down, direction determined by level at input pin T2EX • No interrupt is generated • Count up <ul style="list-style-type: none"> - Start counting from 16-bit reload value, overflow at FFFF_H - Reload event triggered by overflow condition - Programmable reload value in register RC2 • Count down <ul style="list-style-type: none"> - Start counting from FFFF_H, underflow at value defined in register RC2 - Reload event triggered by underflow condition - Reload value fixed at FFFF_H

(table continues...)

16 Timer2 and Timer21

Table 10 (continued) **Timer2 and Timer21 modes**

Mode	Description
Channel capture	<ul style="list-style-type: none">• Count up only• Start counting from 0000_H, overflow at FFFF_H• Reload event triggered by overflow condition• Reload value fixed at 0000_H• Capture event triggered by falling/rising edge at pin T2EX• Captured timer value stored in register RC2• Interrupt is generated with reload or capture event

17 Capture/compare unit 6 (CCU6)

17.1 Feature set overview

This section gives an overview over the different building blocks and their main features.

Timer 12 block features

- Three capture/compare channels, each channel can be used either as capture or as compare channel
- Generation of a three-phase PWM supported (six outputs, individual signals for high-side and low-side switches)
- 16-bit resolution, maximum count frequency = peripheral clock
- Dead-time control for each channel to avoid short-circuits in the power stage
- Concurrent update of T12 registers
- Center-aligned and edge-aligned PWM can be generated
- Single-shot mode supported
- Start can be controlled by external events
- Capability of counting external events
- Multiple interrupt request sources
- Hysteresis-like control mode

Timer 13 block features

- One independent compare channel with one output
- 16-bit resolution, maximum count frequency = peripheral clock
- Concurrent update of T13 registers
- Can be synchronized to T12
- Interrupt generation at period-match and compare-match
- Single-shot mode supported
- Start can be controlled by external events
- Capability of counting external events

Additional specific functions

- Block commutation for brushless DC-drives implemented
- Position detection via Hall-sensor pattern
- Noise filter supported for position input signals
- Automatic rotational speed measurement and commutation control for block commutation
- Integrated error handling
- Fast emergency stop without CPU load via external signal ($\overline{\text{CTRAP}}$)
- Control modes for multichannel AC-drives
- Output levels can be selected and adapted to the power stage

17 Capture/compare unit 6 (CCU6)

17.2 Introduction

The CCU6 unit is made up of a timer T12 block with three capture/compare channels and a timer T13 block with one compare channel. The T12 channels can independently generate PWM signals or accept capture triggers, or they can jointly generate control signal patterns to drive AC motors or inverters.

A rich set of status bits, synchronized updating of parameter values via shadow registers, and flexible generation of interrupt request signals provide means for efficient software control.

Note: *The capture/compare module itself is named CCU6 (capture/compare unit 6). A capture/compare channel inside this module is named CC6x.*

17.2.1 Block diagram

The timer T12 can work in capture and/or compare mode for its three channels. The modes can also be combined (e.g. a channel works in compare mode, whereas another channel works in capture mode). The timer T13 can work in compare mode only. The multichannel control unit generates output patterns which can be modulated by T12 and/or T13. The modulation sources can be selected and combined for the signal modulation.

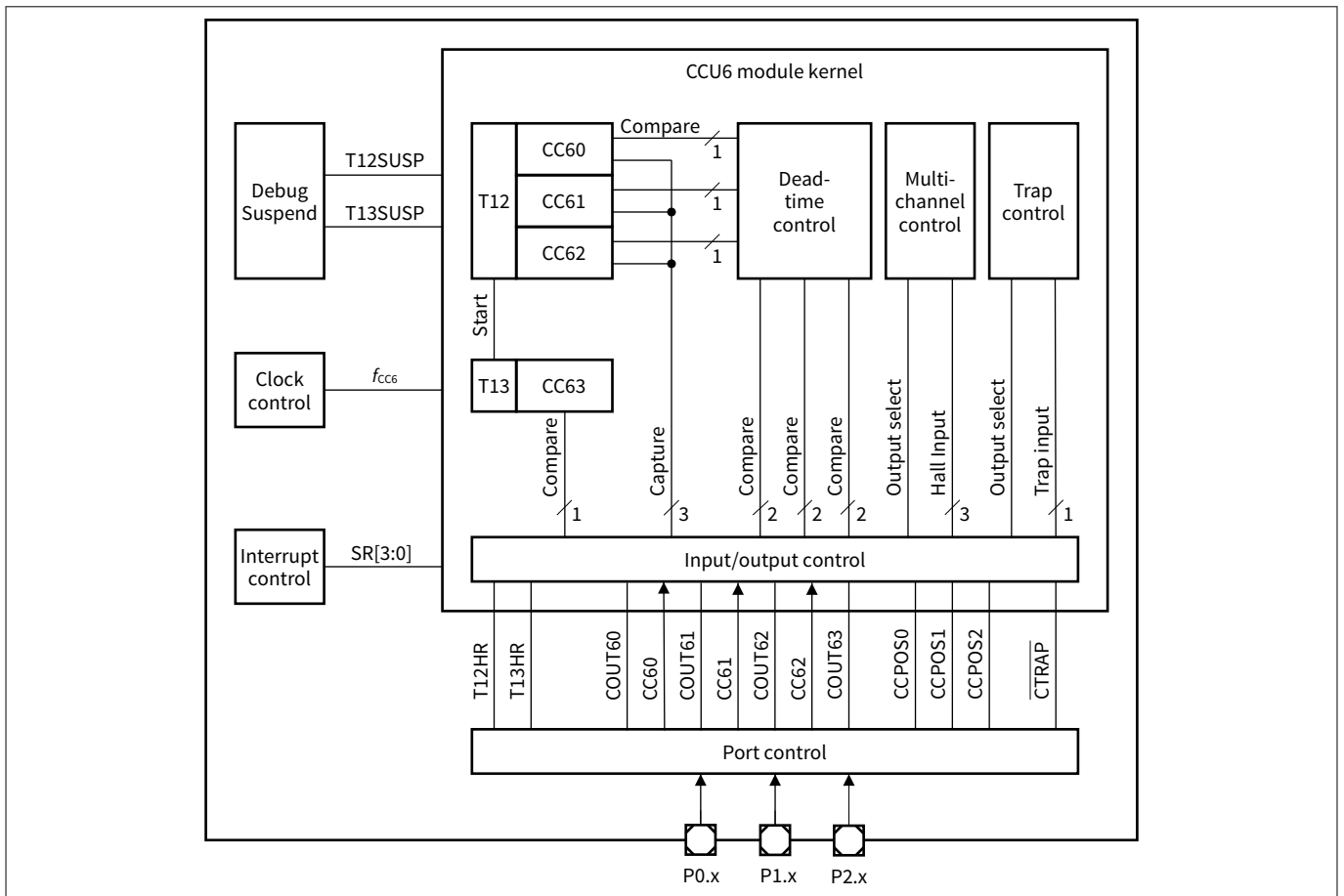

Figure 24 CCU6 block diagram

18 UART1/UART2

18.1 Features

- Full-duplex asynchronous modes
 - 8-bit or 9-bit data frames, LSB first
 - Fixed or variable baud-rate
- Receive buffered (1 Byte)
- Multiprocessor communication
- Interrupt generation on the completion of a data transmission or reception
- Baud-rate generator with fractional divider for generating a wide range of baud-rates, e.g. 9.6 kBaud, 19.2 kBaud, 115.2 kBaud, 125 kBaud, 250 kBaud, 500 kBaud
- Hardware logic for break and sync byte detection
- for UART1: LIN support: connected to timer channel for synchronization to LIN baud-rate

In all modes, transmission is initiated by any instruction that uses SBUF as a destination register. Reception is initiated in the modes by the incoming start bit if REN = 1.

The serial interface also provides interrupt requests when transmission or reception of the frames has been completed. The corresponding interrupt request flags are TI or RI, respectively. If the serial interrupt is not used (that means serial interrupt not enabled), TI and RI can also be used for polling the serial interface.

18.2 Introduction

The UART1/UART2 provide a full-duplex asynchronous receiver/transmitter, that is it can transmit and receive simultaneously. They are also receive-buffered, that is, they can commence reception of a second byte before a previously received byte has been read from the receive register. However, if the first byte still has not been read by the time reception of the second byte is complete, the previous byte will be lost. The serial port receive and transmit registers are both accessed at special function register (SFR) SBUF. Writing to SBUF loads the transmit register, and reading SBUF accesses a physically separate receive register.

18 UART1/UART2

18.2.1 Block diagram

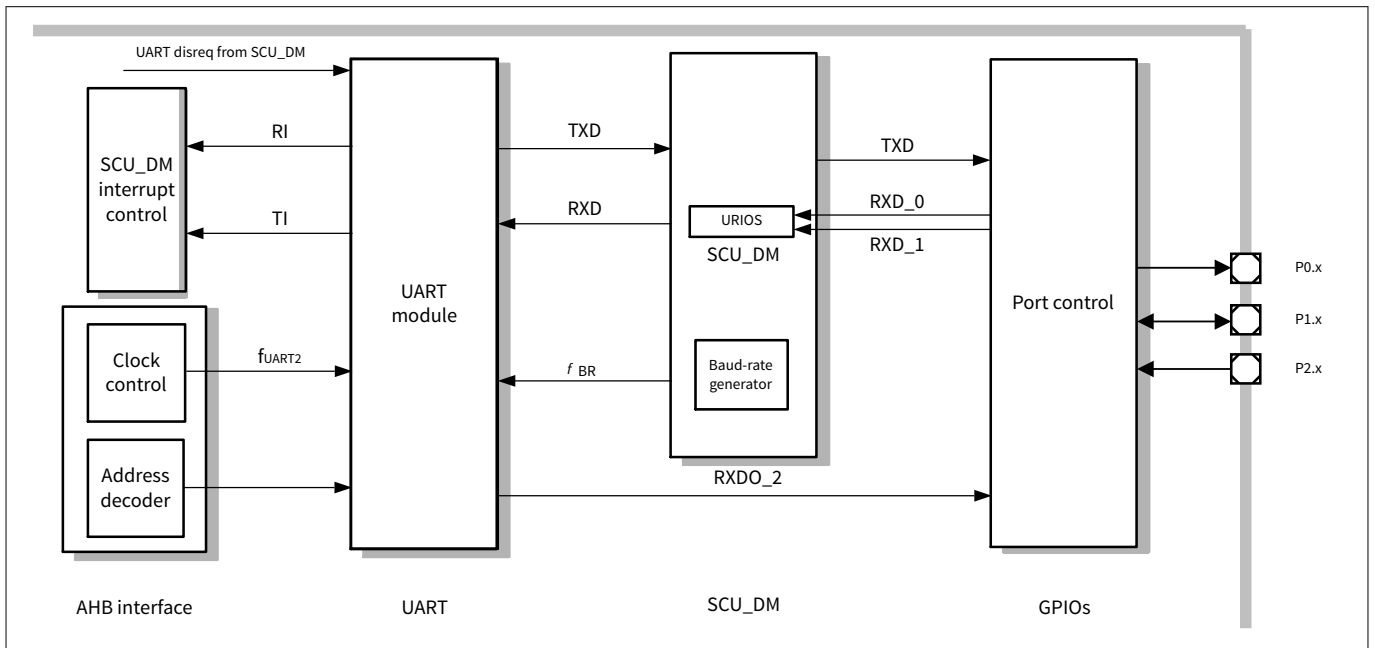

Figure 25 **UART block diagram**

18 UART1/UART2

18.3 UART modes

The UART1/UART2 can be used in four different modes. In mode 0, it operates as an 8-bit shift register. In mode 1, it operates as an 8-bit serial port. In modes 2 and 3, it operates as a 9-bit serial port. The only difference between mode 2 and mode 3 is the baud-rate, which is fixed in mode 2 but variable in mode 3. The variable baud-rate is set by the underflow rate on the dedicated baud-rate generator.

The different modes are selected by setting bits SM0 and SM1 to their corresponding values, as shown in the following table.

Mode 1 example: 8 data bits, 1 start bit, 1 stop bit, no parity selection, 16 times oversampled (majority decision of bits 6, 7, 8), receive and transmit register double buffered, Tx/Rx IRQ(s).

Table 11 **UART modes**

SM0	SM1	Operating mode	baud-rate
0	0	Mode 0: 8-bit shift register	$f_{sys}/2$
0	1	Mode 1: 8-bit shift UART	Variable
1	0	Mode 2: 9-bit shift UART	$f_{sys}/64$ or $f_{sys}/32$
1	1	Mode 3: 9-bit shift UART	Variable

19 LIN/CXPI transceiver (TRX)

19 LIN/CXPI transceiver (TRX)

19.1 Features

19.1.1 General functional features

- LIN transceiver compliant to LIN2.2 standard, backward compatible to LIN2.1, LIN2.0 and LIN1.3
- LIN transceiver compliant to SAE-J2602 (slew-rate, receiver hysteresis)
- LIN transceiver compliant to ISO17987 (physical layer)
- CXPI transceiver compliant to ISO20794 (physical layer)
- LIN communication supported via UART1 interface
- CXPI communication supported via MXCXPI protocol controller

19.1.2 Mode of operation

- Transceiver Normal mode
- Transceiver Receive-Only mode
- Transceiver Sleep (wake-capable) mode
- Transceiver Off mode

19.1.3 Special features

- LIN baud-rate measurement via Timer2
- CXPI wake-up timing measurements via Timer2
- Transceiver type selection (LIN or CXPI) via SFR. The transceiver type must be selected at the device start-up and can not be changed during operation.
- Dominant TXD timeout feature.
- Transceiver port can be configured as standard HV I/O (LHVIO) via SFR
- Transceiver port overcurrent limitation and overtemperature protection
- Transceiver fully resettable via enable bit

19.1.4 Slope mode features

- LIN normal slope mode (up to 20 kbits/s)
- LIN flash mode (up to 115 kbits/s or 250 kbits/s)

19.1.5 Wake-up features

- LIN network wake-up
- CXPI network wake-up

19 LIN/CXPI transceiver (TRX)

19.2 Introduction

The transceiver supports the Local Interconnect Network (LIN) compliant to the LIN2.2 standard, backwards compatible to LIN1.3, LIN2.0 and LIN2.1. The transceiver operates as a bus driver located in between the protocol controller and the physical network. The LIN network is a single wire, bi-directional bus featuring baud-rates ranging from 2.4 kBaud to 20 kBaud. Additional baud-rates up to 62.5 kBaud are implemented.

The integrated slope control allows to use several data transmission rates with optimized EMC performance. For data transfer at the end-of-line, a Flash mode featuring up to 115 kBaud is implemented.

The transceiver supports the automotive communication network with Clock Extension Peripheral Interface (CXPI). The transceiver has a flexible bit rate ranging from 4.8 kBaud to 20 kBaud, supports commander and responder operation and is ISO CXPI compliant.

The integrated transceiver is supporting LIN and CXPI communication standards. The transceiver type must be selected (via the SCUPM_PKGCFG1 register) at the device start-up and must not be changed during operation.

The transceiver converts the data stream on the TXD input into a bus signal using a current-limited wave-shaping driver which reduces electromagnetic emissions (EME). The receiver converts the data stream to logic level signals that are sent out via the RXD output.

Ultra-low power consumption is possible using the Sleep (wake-capable) mode which allows wake-up via the communication network.

Furthermore, the transceiver can be used as a high voltage input/output (LHVIO) controlled by SFR bits (see LIN_CTRL.TXD and LIN_CTRL.RXD bit description).

19 LIN/CXPI transceiver (TRX)

19.2.1 Block diagram

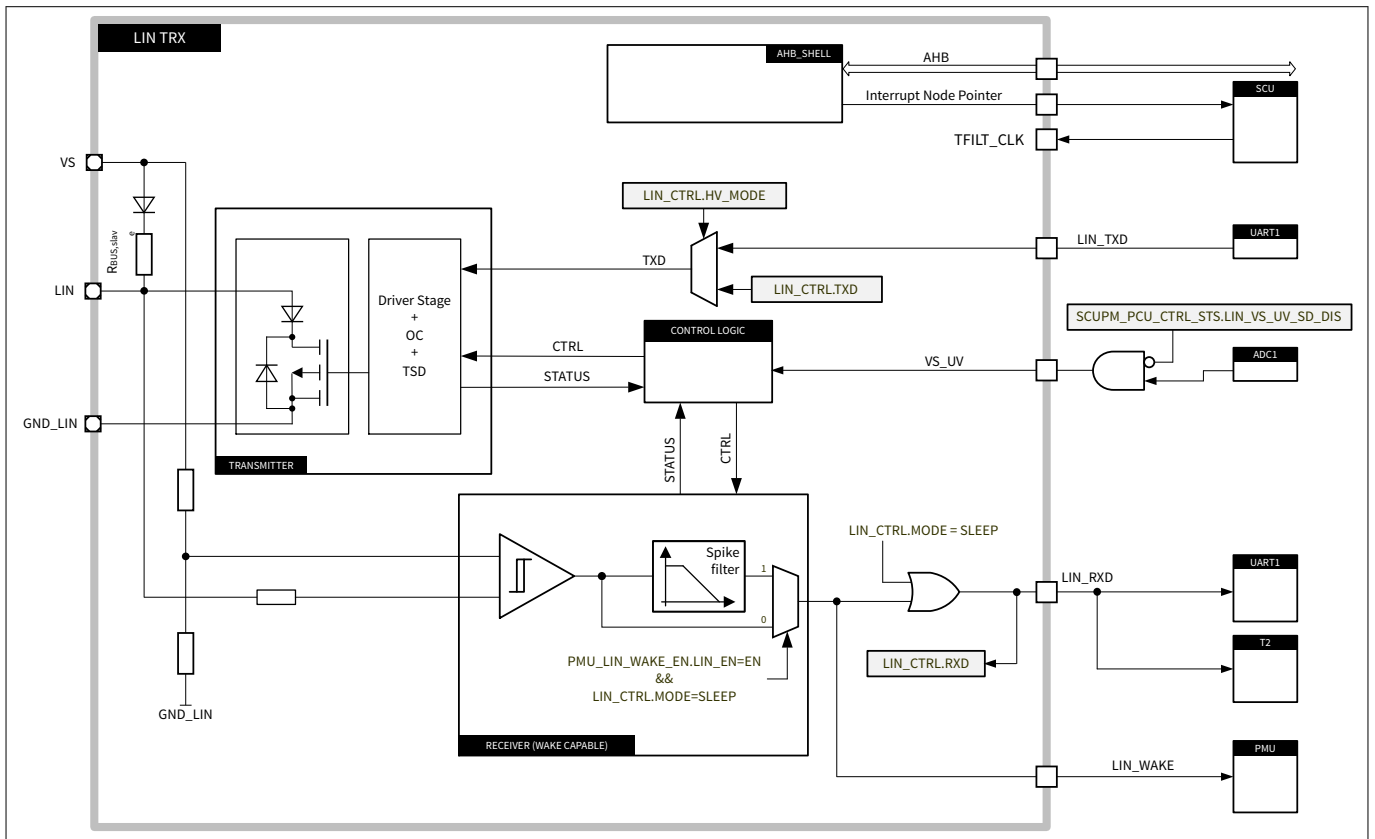

Figure 26 LIN transceiver block diagram

19 LIN/CXPI transceiver (TRX)

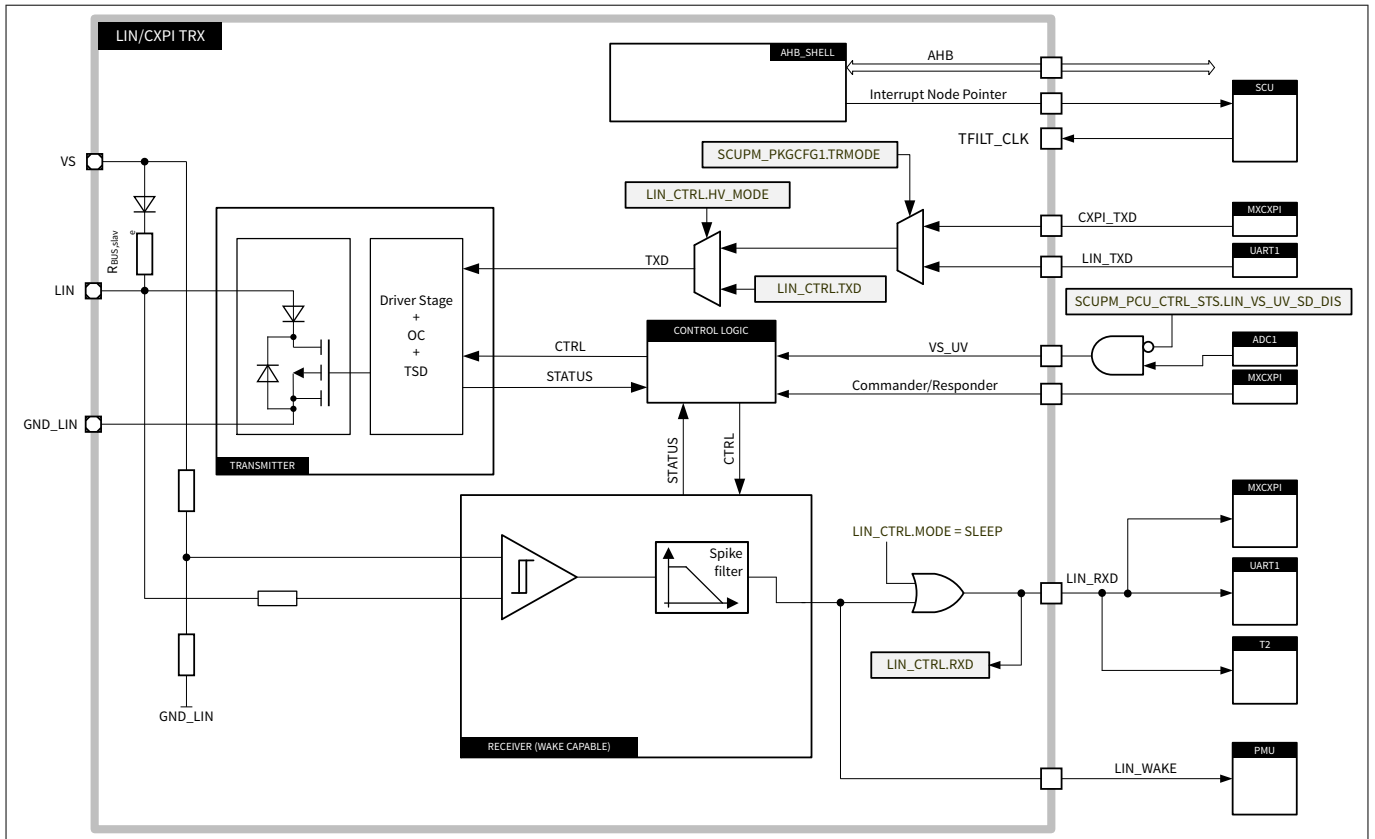

Figure 27 CXPI transceiver block diagram

Note: The LIN_WAKE signal, originating from the bus, serves as the source for LIN_RXD. However, it can only be transmitted to LIN_RXD when the system is in active mode.

20 CXPI protocol controller (MXCXPI)

20.1 Features

- The MXCXPI module is compliant to ISO 20794 including the controller specification
- Channel implementation uses a fixed oversampling factor of 400
- Commander and responder modes
- Polling method for both normal frame and long frame
- Pulse Width Modulation (PWM) mode
- Collision Resolution and Carrier Sense Multiple Access
- Bitrate up to 20 kbps
- Wake pulse generation and detection (*Note: The wake up feature is implemented in conjunction with the Timer2 module.*)
- Clock detection
- CRC8 and CRC16 support for both normal frame and long frame respectively
- Error detection
- Single channel
- Dedicated transmit and receive FIFOs with depth of 16 bytes
- The module supports test modes

20 CXPI protocol controller (MXCXPI)

20.2 Introduction

20.2.1 Block diagram

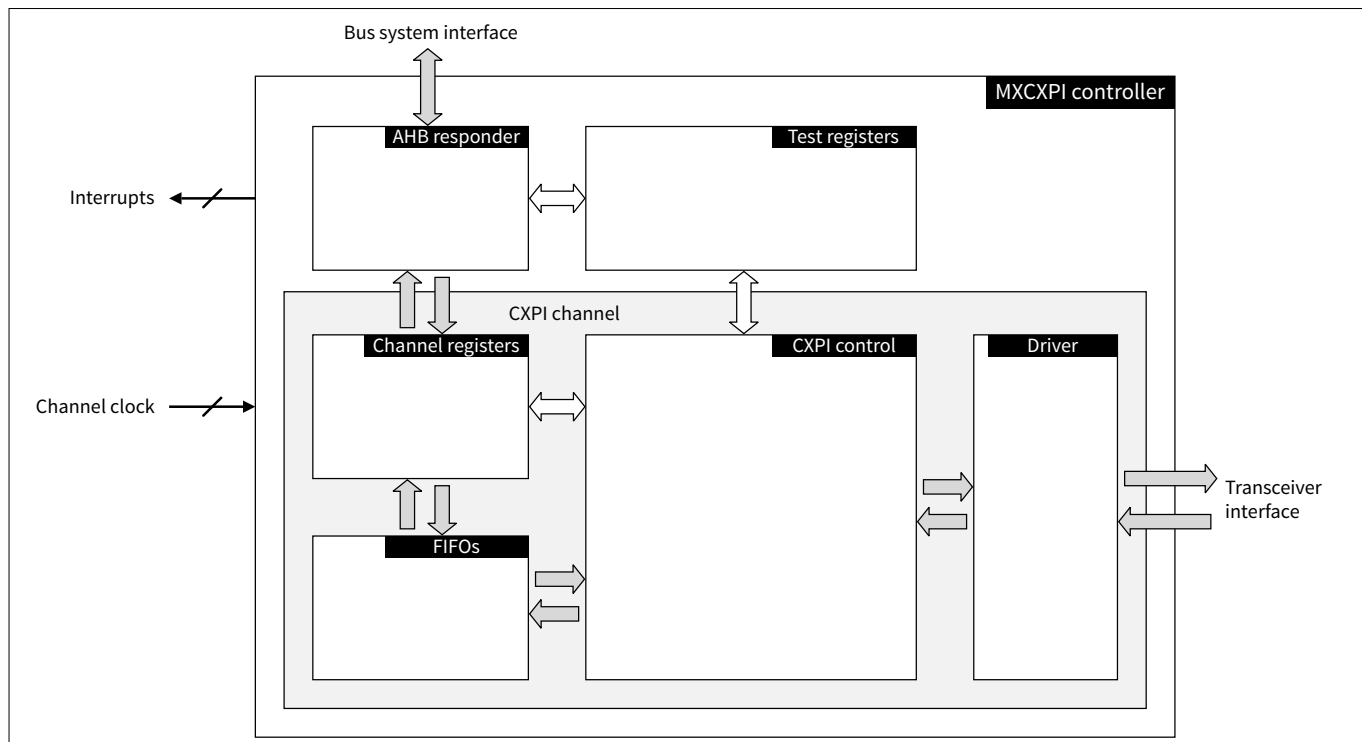

Figure 28 MXCXPI block diagram

21 High-speed synchronous serial interface SSC1/SSC2

21.1 Features

- Commander and responder mode operation
 - Full-duplex or half-duplex operation
- Transmit and receive double buffered
- Flexible data format
 - Programmable number of data bits: 2 to 16 bits
 - Programmable shift direction: Least significant bit (LSB) or most significant bit (MSB) shift first
 - Programmable clock polarity: idle low- or high-state for the shift clock
 - Programmable clock/data phase: data shift with leading or trailing edge of the shift clock
- Variable baud-rate, e.g. 250 kBaud to 8 MBaud
- Compatible with serial peripheral interface (SPI)
- Interrupt generation
 - On a transmitter empty condition
 - On a receiver full condition
 - On an error condition (receive, phase, baud-rate, transmit error)
 - On a transfer complete condition
- Port direction selection, see [Chapter 14](#)

21.2 Introduction

The high-speed synchronous serial interface (SSC) supports both full-duplex and half-duplex serial synchronous communication. The serial clock signal can be generated by the SSC internally (commander mode), using its own 16-bit baud-rate generator, or can be received from an external commander (responder mode). Data width, shift direction, clock polarity, and phase are programmable. This allows communication with SPI-compatible devices or devices using other synchronous serial interfaces.

Data is transmitted or received on lines TXD and RXD, which are normally connected to the pins CTRR (commander transmit/responder receive) and CRRT (commander receive/responder transmit). The clock signal is output through line MS_CLK (commander serial shift clock) or input through line SS_CLK (responder serial shift clock). Both lines are normally connected to the pin SCLK. Transmission and reception of data are double-buffered.

21 High-speed synchronous serial interface SSC1/SSC2

21.2.1 Block diagram

The following figure shows all functional relevant interfaces associated with the SSC kernel.

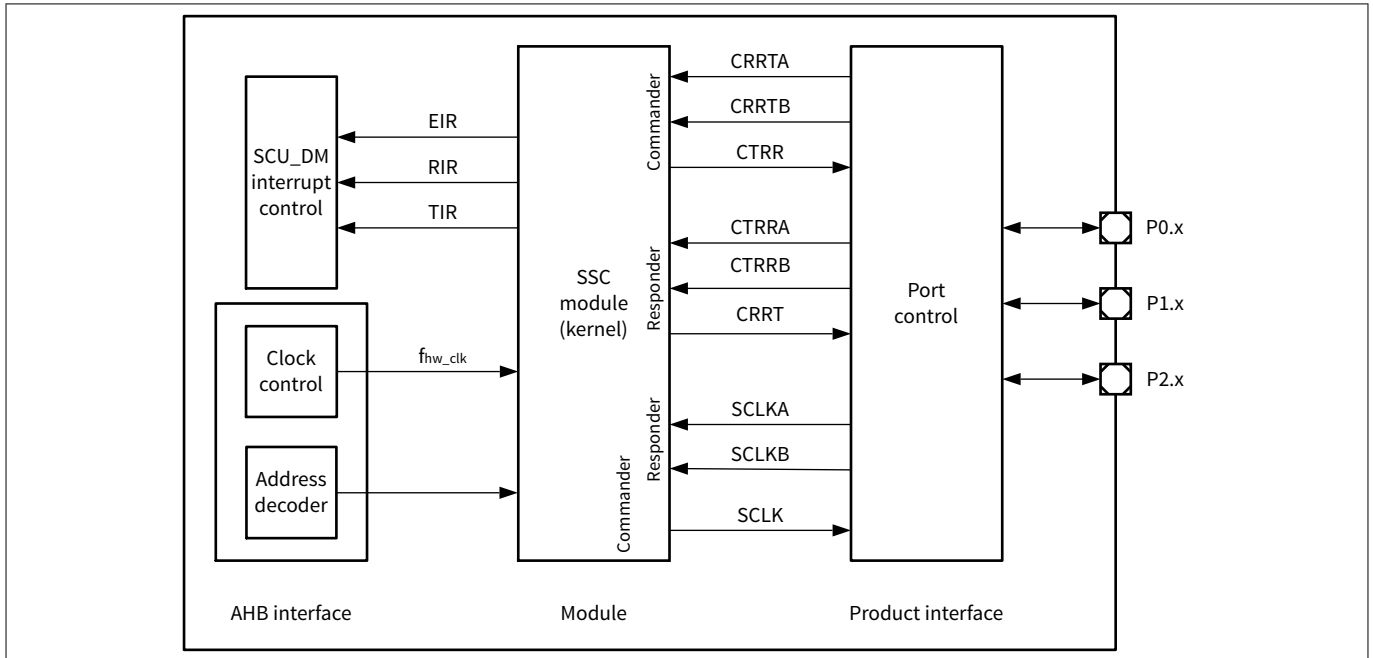

Figure 29 SSC interface diagram

22 Measurement unit

22 Measurement unit

22.1 Features

- 1 × 10-bit ADC with 13 inputs including attenuator allowing measurement of high voltage input signals
- Supply voltage attenuators with attenuation of VBAT_SENSE, VS, MONx, P2.x
- 1 × 8-bit ADC with 7 inputs including attenuator allowing measurement of high voltage input signals
- Supply voltage attenuators with attenuation of VS, VDDEXT, VDDP, VBG, VDDC, TSENSE_LS, TSENSE_CENTRAL
- VBG monitoring of 8-bit ADC to support functional safety requirements
- Temperature sensor for monitoring the chip temperature and low-side module temperature
- Supplement block with reference voltage generation, bias current generation, voltage buffer for NVM reference voltage, voltage buffer for analog module reference voltage and test interface

22.2 Introduction

The measurement unit is a functional unit that comprises the following associated submodules:

Table 12 Measurement functions and associated modules

Module Name	Modules	Functions
Central functions unit	Bandgap reference circuit + current reference circuit	The bandgap-reference submodule provides two reference voltages: <ol style="list-style-type: none"> 1. An accurate reference voltage for the 10-bit and 8-bit ADCs. A local dedicated bandgap circuit is implemented to avoid deterioration of the reference voltage arising e.g. from crosstalk or ground voltage shift 2. The reference voltage for the NVM module
10-bit ADC (ADC1)	10-bit ADC module with 13 multiplexed analog inputs	VBAT_SENSE, VS and MONx measurement Six (5 V) analog inputs from port 2.x
8-bit ADC (ADC2)	8-bit ADC module with 7 multiplexed inputs	VS/VDDEXT//VDDP/VBG/VDDC/TSENSE_LS and TSENSE_CENTRAL measurement
Temperature sensor	Temperature sensor readout amplifier with two multiplexed ΔV_{be} -sensing elements	Generates outputs voltage which is a linear function of the local chip (T_j) temperature
Measurement core module	Digital signal processing and ADC control unit	<ol style="list-style-type: none"> 1. Generates the control signal for the 8-bit ADC2 and the synchronous clock for the switched capacitor circuits (temperature sensor) 2. Performs digital signal processing functions and provides status outputs for interrupt generation

22 Measurement unit

22.2.1 Block diagram

The structure of the measurement functions module is shown in the following figure.

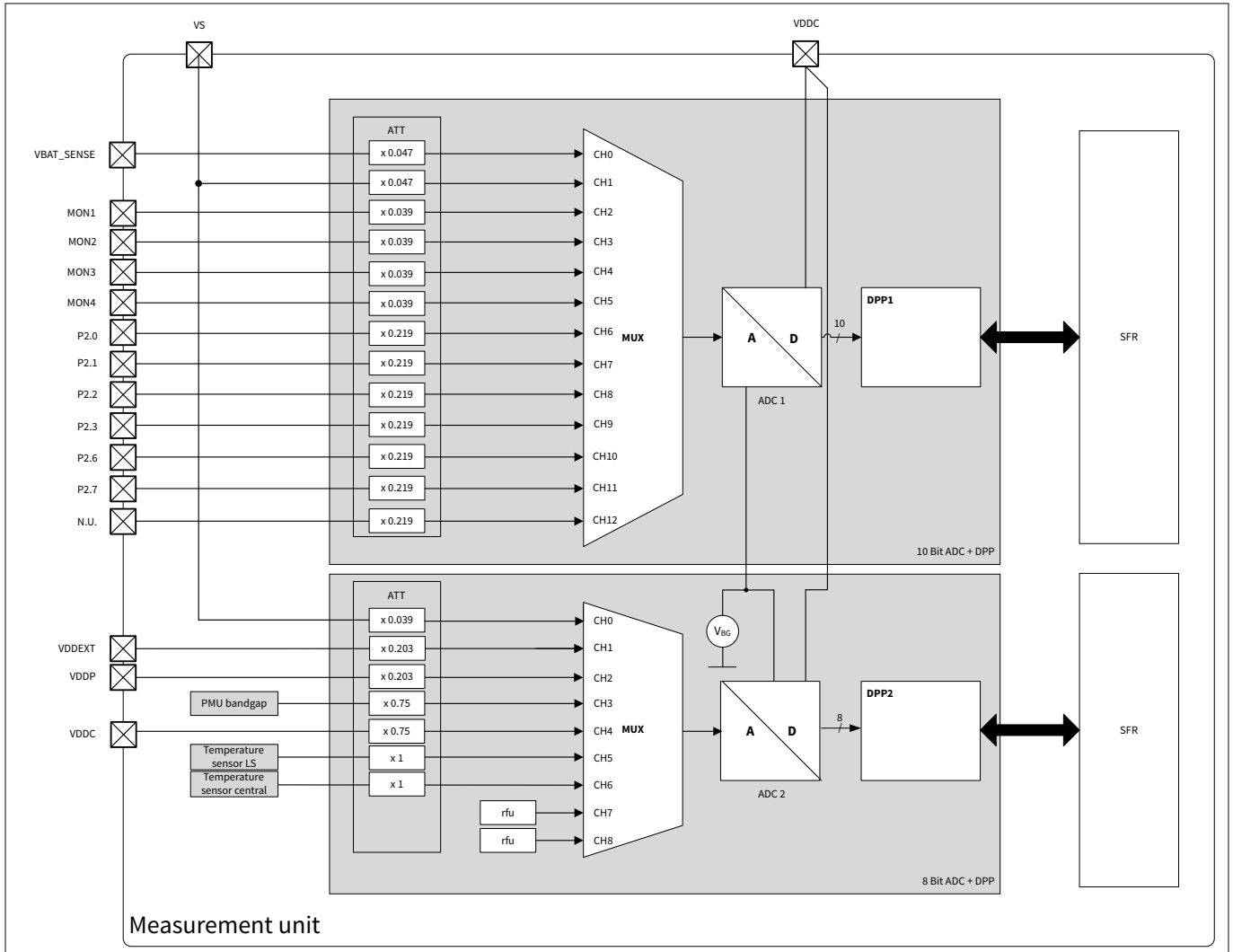

Figure 30 TLE9844QXC measurement unit overview

23 Measurement core module (incl. ADC2)

23.1 Features

- 7 individually programmable channels split into two groups of user configurable and non user configurable
- Individually programmable channel prioritization scheme for measurement unit
- Two independent filter stages with programmable low-pass and time filter characteristics for each channel
- Two channel configurations:
 - Programmable upper- and lower trigger thresholds comprising a fully programmable hysteresis
 - Two individually programmable trigger thresholds with limit hysteresis settings
- Individually programmable interrupts and status for all channel thresholds
- Operation down to reset threshold of entire system

23.2 Introduction

The basic function of this block is the digital post-processing of several analog digitized measurement signals by means of filtering level comparison and interrupt generation. The measurement post-processing block is built of seven identical channel units attached to the outputs of the 7-channel 8-bit ADC (ADC2). It processes seven channels, where the channel sequence and prioritization is programmable within a wide range.

23.2.1 Block diagram

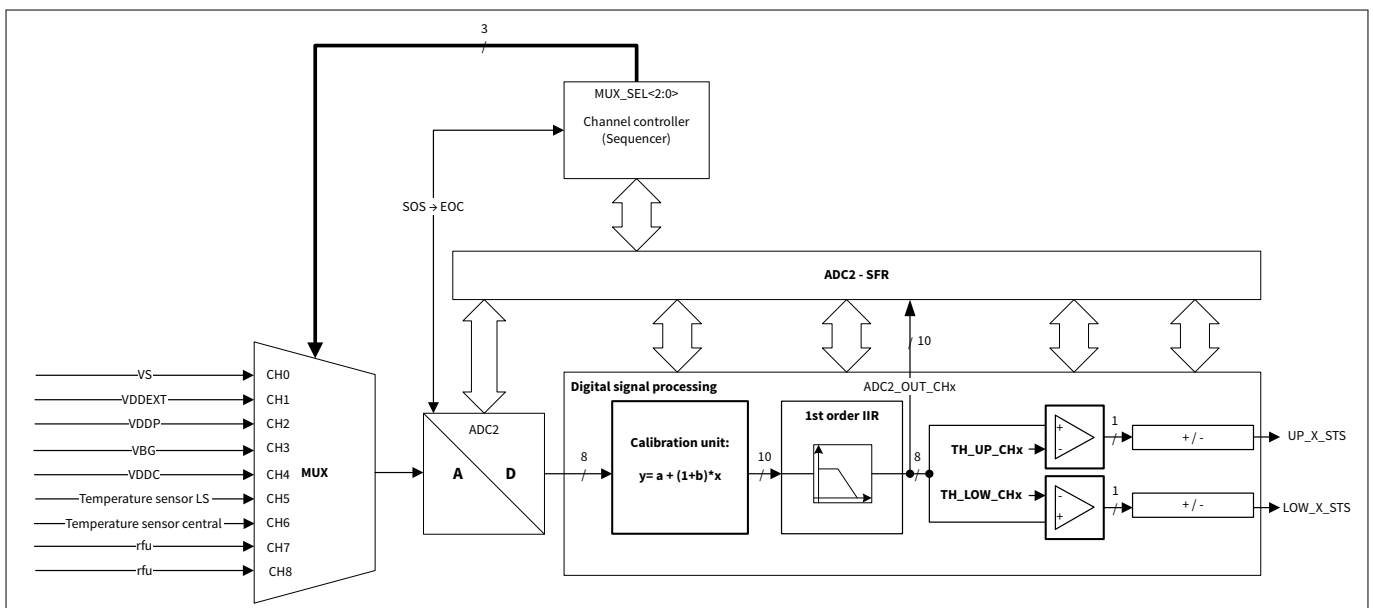

Figure 31 Module block diagram

24 10-bit analog digital converter (ADC1)

24.1 Features

The basic function of this block is the digital post-processing of several analog digitized measurement signals by means of filtering, level comparison and interrupt generation. The measurement post-processing block is built of twelve identical channel units attached to the outputs of the 13-channel 10-bit ADC. It processes twelve channels, where the channel sequence and prioritization is programmable within a wide range.

Functional features

- 10-bit SAR ADC with conversion time of 17 clock cycles
- Programmable clock divider for sequencer and ADC
- 12 individually programmable channels (ch0...ch11):
 - 6 HV channels: VS, VBAT_SENSE, MON1...MON4
 - 6 LV channels: P2.1, P2.2, P2.3, P2.6, P2.7, P2.0
- All channels are fully calibrated and user configurable
- Individually programmable channel prioritization scheme for digital post-processing (dpp)
- Two independent filter stages with programmable low-pass and time filter characteristics for each channel
- Two channel configurations:
 - Programmable upper and lower trigger thresholds comprising a fully programmable hysteresis
 - Two individually programmable trigger thresholds with limit hysteresis settings
- Individually programmable upper threshold and lower threshold interrupts and status for all channel thresholds
- ADC reference completely integrated

Note: *In case the MONx should be evaluated by the ADC1, it is recommended to add 6.8 nF capacitors close to the MONx pin of the device, in order to build an external RC filter to limit the bandwidth of the input signal.*

24 10-bit analog digital converter (ADC1)

24.2 Introduction

24.2.1 Block diagram

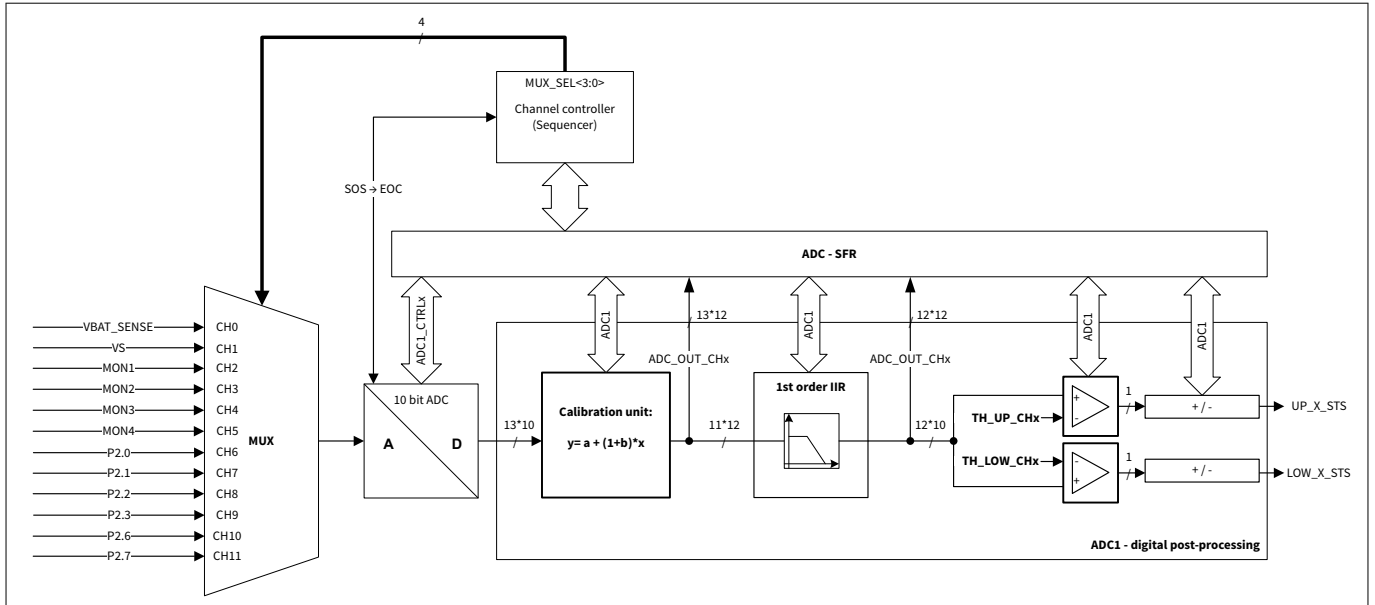

Figure 32 Module block diagram

25 High-voltage monitor input

25.1 Features

Features

- 4 high-voltage monitor inputs with $V_{S}/2$ threshold voltage
- Wake capability for system Stop mode and system Sleep mode
- Edge sensitive wake-up feature configurable for transitions from low to high, high to low or both directions
- MON inputs can also be evaluated with ADC in Active mode, using adjustable threshold values (see also [Chapter 24](#))
- Selectable pull-up and pull-down current sources available

25.2 Introduction

This module is dedicated to monitor external voltage levels above or below a specified threshold. Each MONx pin can further be used to detect a wake-up event by detecting a level change by crossing the selected threshold. This applies to any power mode. Furthermore, each MONx pin can be sampled by the ADC as analog input.

25.2.1 Block diagram

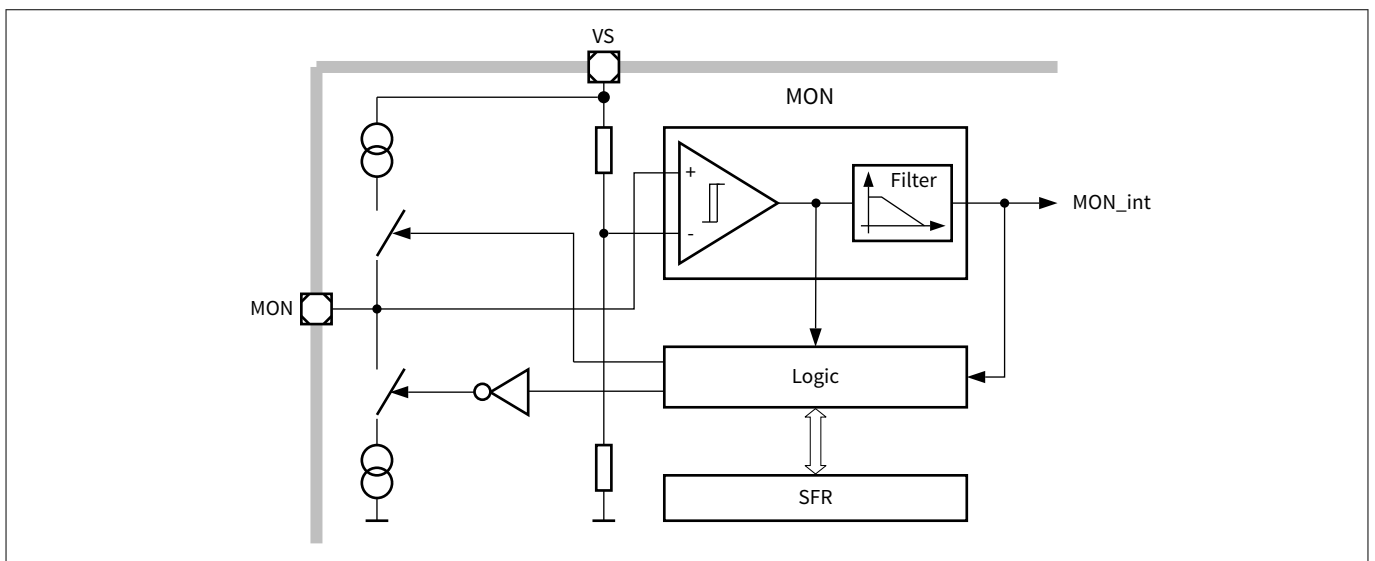

Figure 33 Monitoring input block diagram

26 High-side switch

26.1 Features

The high-side switch is optimized for driving resistive loads. Only small line inductance are allowed. Typical applications are single or multiple LEDs of a dashboard, switch illumination or other loads that require a high-side switch.

A cyclic switch activation during Sleep mode or Stop mode of the system is also available.

Functional features

- Multi-purpose high-side switch for resistive load connections (only small line inductances are allowed)
- Overcurrent limitation
- Overcurrent detection with thresholds: 25 mA, 50 mA, 100 mA, 150 mA and automatic shutdown
- Overtemperature detection and automatic shutdown
- Open load detection in on mode with open load current of max. 1.5 mA
- Interrupt signalling of overcurrent, overtemperature and open load condition
- Cyclic switch activation in Sleep mode and Stop mode with cyclic sense support and reduced driver capability: max. 40 mA
- PWM capability up to 25 kHz
- Internal connection to system-PWM generator (CCU6)
- Slew rate control for low EMI characteristic

Applications hints

- The voltage at HSx must not exceed the supply voltage by more than 0.3 V to prevent a reverse current from HSx to VS

26 High-side switch

26.2 Introduction

26.2.1 Block diagram

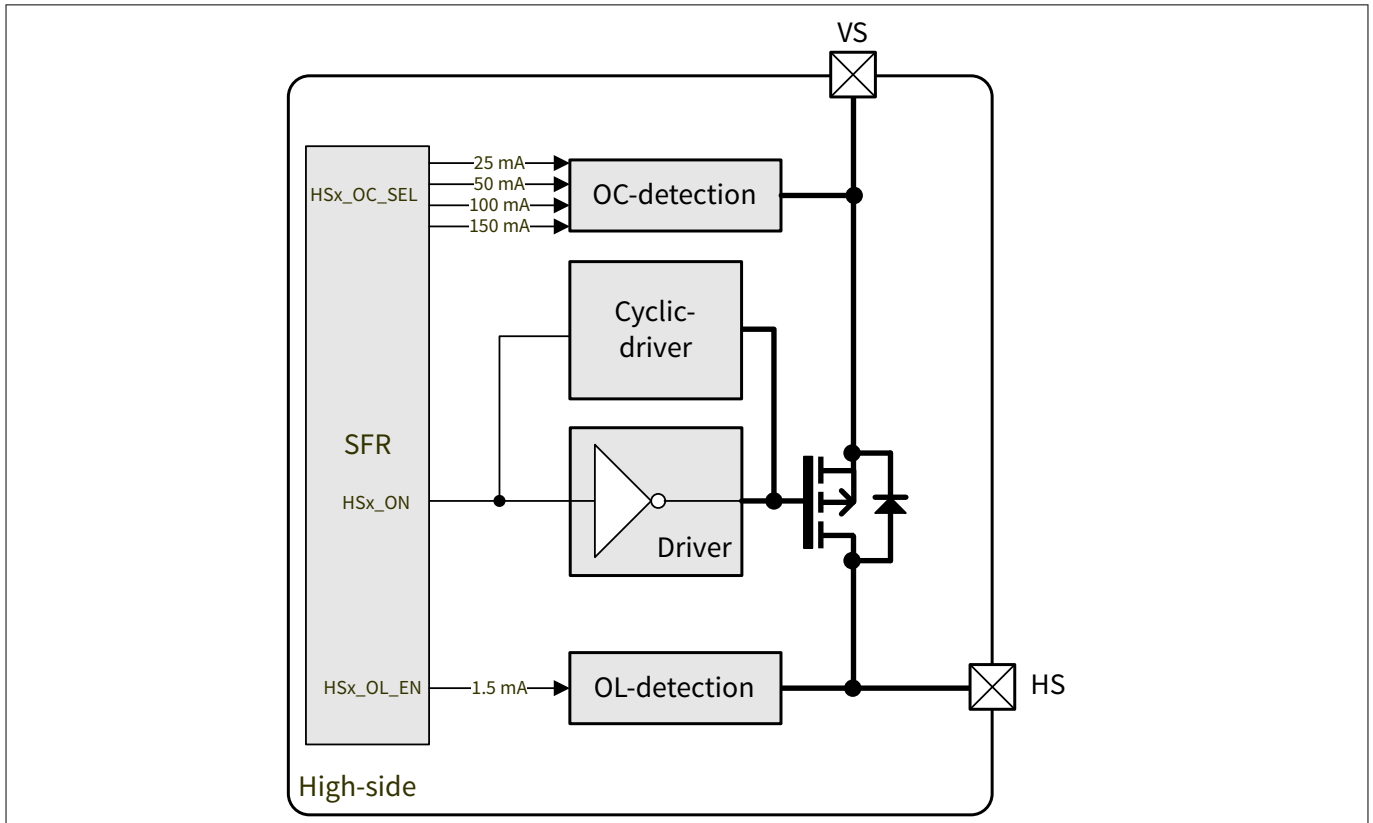

Figure 34 High-side module block diagram (incl. subblocks)

26.2.2 General

The high-side switch can generally be controlled in three different ways:

- In Normal mode the output stage is fully controllable through the SFR registers HSx_CTRL. Protection functions as overcurrent, overtemperature and open load detection are available
- The PWM mode can also be enabled by a HSx_CTRL - SFR bit. The PWM configuration has to be done in the corresponding PWM module. All protection functions are also available in this mode. The maximum PWM frequency must not exceed 25 kHz (disabled slew rate control only)
- The high-side switch provides also the possibility of cyclic switch activation in all low power modes (Sleep mode and Stop mode). In this configuration it has limited functionality with limited current capability. Diagnostic functions are not available in this mode

27 Low-side switch

27.1 Features

The general purpose low-side switch is optimized to control an on-board relay. The low-side switch provides embedded protection functions including overcurrent and overtemperature detection. The module is designed for on-board connections.

Measures for standard ESD (HBM) and EMC robustness are implemented.

Functional features

- Multipurpose low-side switch optimized for driving relays:
 - Simple relay driver
 - PWM relay driver
- Integrated clamping for usage as a simple relay driver
- Overcurrent detection and automatic shutdown
- Overtemperature detection and automatic shutdown
- Interrupt signalling of overcurrent and overtemperature condition
- Open load detection with interrupt signaling
- PWM capability up to 25 kHz (for inductive loads with external clamping circuitry only)
- Selectable PWM source: Dedicated CCU6 channels
- Current drive capability up to min. 270 mA

Applications hints

- It is not recommended to use the switch in PWM mode without external free wheeling diode.

27 Low-side switch

27.2 Introduction

27.2.1 Block diagram

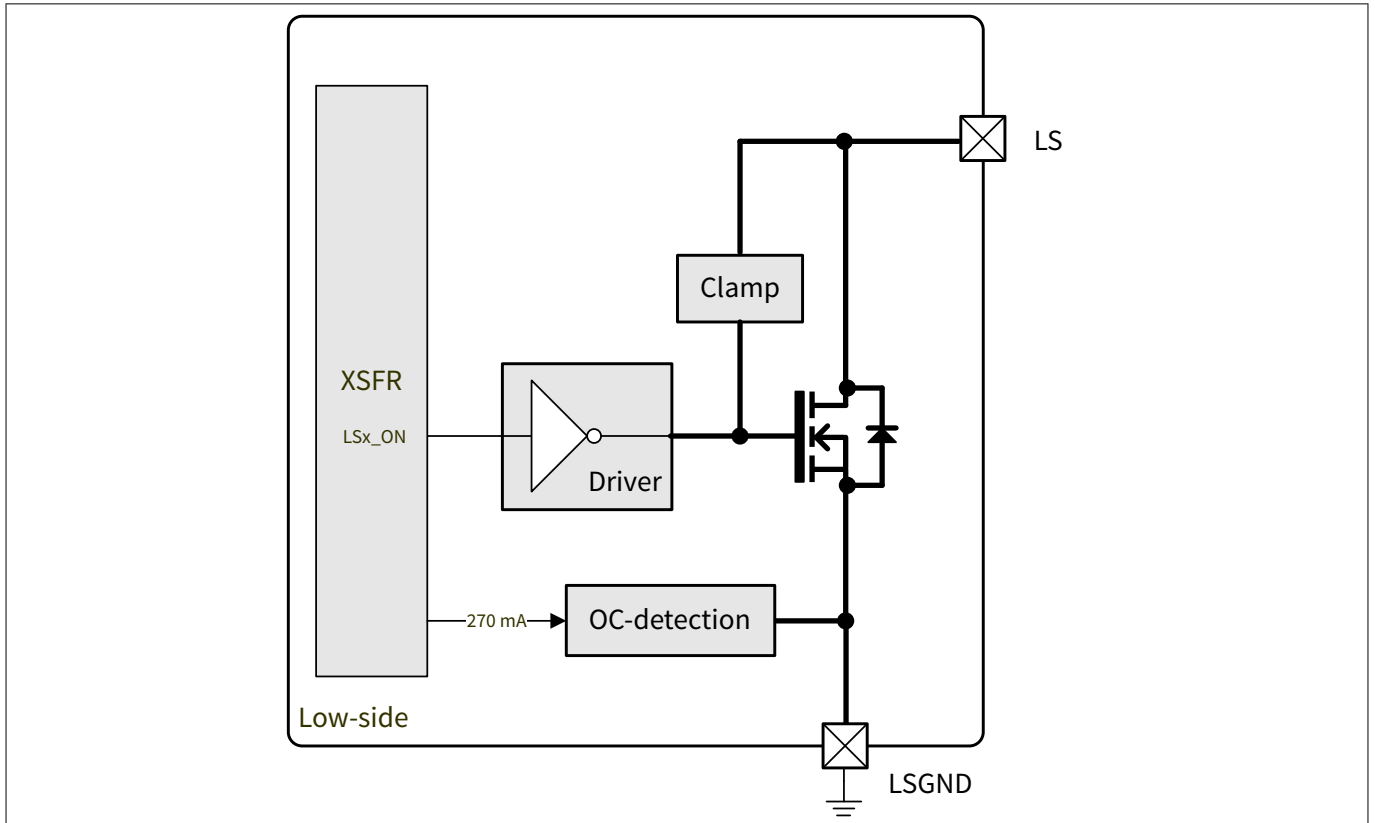

Figure 35 Low-side module block diagram

27.2.2 General

The low-side switches can be generally controlled in two different ways:

- In normal mode the output stage is fully controllable through the SFR registers LSx_CTRL. Protection functions as overcurrent and overtemperature are available
- The PWM mode can also be enabled by a LSx_CTRL - SFR bit. The PWM configuration has to be done in the corresponding PWM module (CCU6). All protection functions are also available in this mode. The maximum PWM frequency must not exceed 25 kHz (fast slew rate only)

28 Application information

28 Application information

Note: *The following information is given as a hint for the implementation of the device only and shall not be regarded as a description or warranty of a certain functionality, condition or quality of the device.*

28.1 Relay window lift application diagram

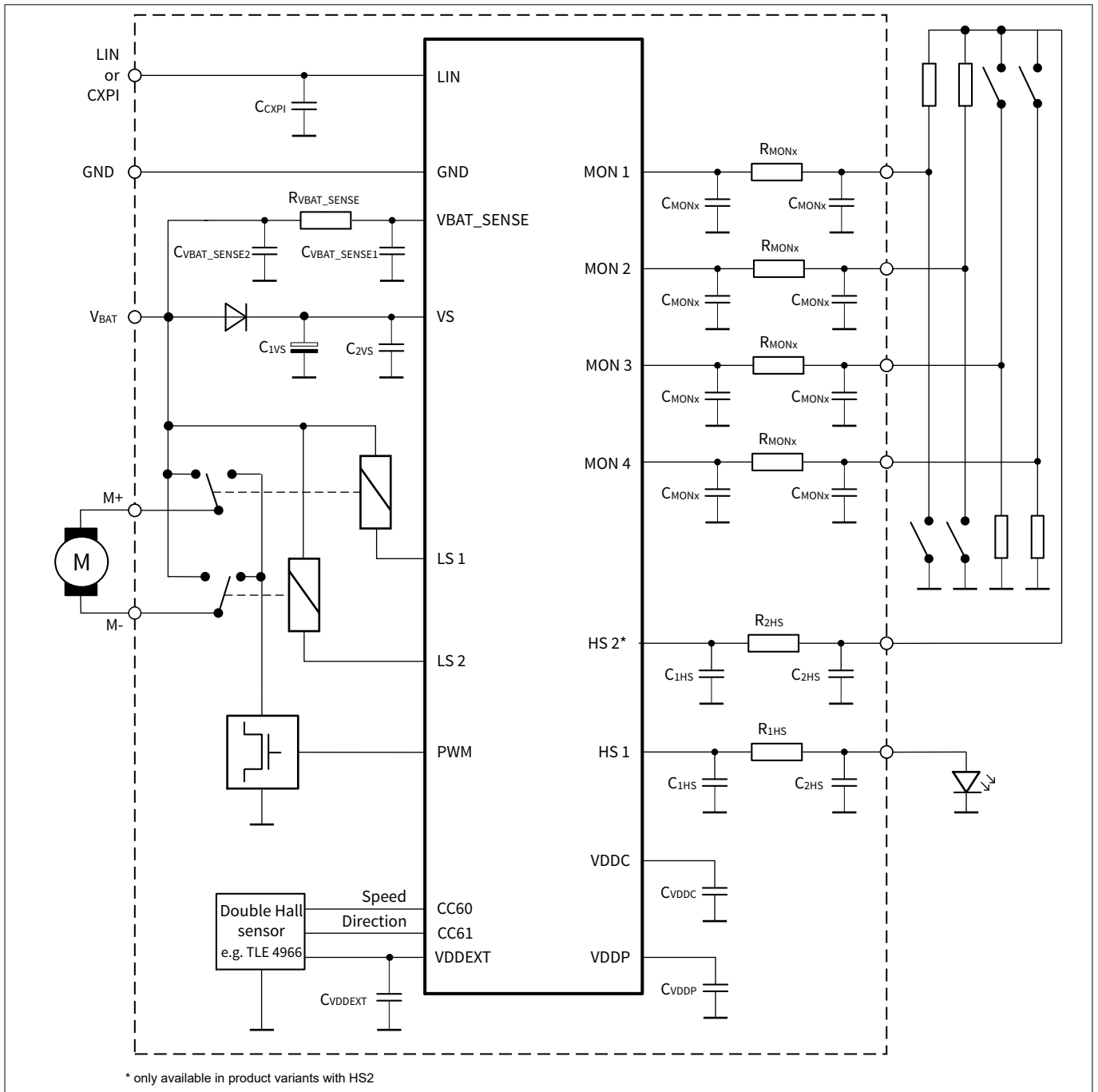

Figure 36 Simplified application diagram example

Note: *This is a very simplified example of an application circuit and bill of material. The function must be verified in the actual application.*

28 Application information

Table 13 External component (BOM)

Symbol	Function	Component
C_{1VS}	Capacitor 1 at VS pin	22 μF ¹⁾
C_{2VS}	Capacitor 2 at VS pin	100 nF ^{2) 3)}
C_{VDDEXT}	Capacitor at VDDEXT pin	330 nF ²⁾
C_{VDDC}	Capacitor at VDDC pin	100 nF ^{2) 3)} + 330 nF ²⁾
C_{VDDP}	Capacitor at VDDP pin	470 nF ^{2) 3)} + 470 nF ²⁾
R_{MONx}	Resistor at MONx pin	3.9 k Ω
C_{MONx}	Capacitor at MONx connector	6.8 nF ⁴⁾
R_{VBAT_SENSE}	Resistor at VBAT_SENSE pin	3.9 k Ω
C_{VBAT_SENSE1}	Capacitor 1 at VBAT_SENSE pin	10 nF ²⁾
C_{VBAT_SENSE2}	Capacitor 2 at VBAT_SENSE connector	6.8 nF ⁴⁾
C_{LIN}	Capacitor at LIN pin	220 pF
R_{1HS}	Resistor at HS pin for LED	e.g. 2.7 k Ω
R_{2HS}	Resistor at HS pin	160 Ω ⁵⁾
C_{1HS}	Capacitor at HS pin	6.8 nF ²⁾
C_{2HS}	Capacitor at HS connector	33 nF ⁴⁾

- 1) To be dimensioned according to application requirements.
- 2) To reduce the effect of fast voltage transients of V_S , these capacitors should be placed close to the device pin.
- 3) Ceramic capacitor.
- 4) For ESD GUN.
- 5) Optional, for short to battery protection, calculated for 24 V (jump start).

28.2 Connection of N.C. / N.U. pins

The device contains several N.C. (not connected, no bond wire) and N.U. (not used, but bonded) pins.

Table 14 Recommendation for connecting N.C. / N.U. pins

Type	Pin number	Recommendation 1	Recommendation 2	Comment
N.C.	27, 28, 29, 38, 40, 41	GND	–	–
N.C.	10, 46	open	GND	Neighboring high-voltage pins
N.U.	4	VS	open	
N.U.	9	GND	–	

28 Application information

28.3 Connection of unused pins

The following table shows recommendations how to connect pins, in case they are not needed by the application.

Table 15 Recommendation for connecting unused pins

Type	Pin number	Recommendation 1 (if unused)	Recommendation 2 (if unused)
LIN	1	open	–
HS1	3	VS	open
MON	5, 6, 7, 8	GND	open + configure internal PU/PD
LS1, LS2	11, 12	GNDLS	open
GPIO	14, 15, 16, 17, 20, 22, 23, 24, 25, 26, 33, 34, 35, 36, 37, 39	GND	External PU/PD or open + configure internal PU/PD
TMS	18	GND	–
Reset	21	open	–
P2/XTAL out	31	open	–
P2/XTAL in	32	GND	–
VDDEXT	45	open	–
VBAT_SENSE	48	VS	–

28.4 Connection of P0.2 for SWD debug mode

To enter the SWD debug mode, P0.2 needs to be 0 at the rising edge of the reset signal.

P0.2 has an internal pull-down, so it just needs to be ensured that there is no external 1 at P0.2 when the debug mode is entered.

28.5 Connection of TMS

For the debug mode, the TMS pin needs to be 1 at the rising edge of the reset signal. This is controlled by the debugger. The TMS pin has an internal PD.

To avoid the device entering the debug mode unintendedly in the final application, adding an external pull-down additionally is recommended.

28 Application information

28.6 ESD immunity according to ISO10605

Note: Tests for ESD robustness according to ISO10605 “gun test” (150 pF, 330 Ω) were performed. The results and test condition are available in a test report. The achieved values for the test are listed in the table below.

Table 16 ESD “Gun test”

Performed test	Result	Unit	Remarks
ESD at pin <i>LIN</i> , versus <i>GND</i>	≥8	kV	¹⁾ Positive pulse
ESD at pin <i>LIN</i> , versus <i>GND</i>	≤-8	kV	¹⁾ Negative pulse
ESD at pin <i>VS</i> , <i>VBAT_SENSE</i> , <i>MONX</i> , <i>HS</i> , versus <i>GND</i>	≥6	kV	¹⁾ Positive pulse
ESD at pin <i>VS</i> , <i>VBAT_SENSE</i> , <i>MONX</i> , <i>HS</i> , versus <i>GND</i>	≤-6	kV	¹⁾ Negative pulse

¹⁾ ESD susceptibility “ESD GUN”, tested by external test house (IBEE Zwickau), according to IEC62228-7 (CXPI).

29 Electrical characteristics

29 Electrical characteristics

This chapter includes all relevant electrical characteristics of the product TLE9844QXC.

29.1 General characteristics

29.1.1 Absolute maximum ratings

Table 17 Absolute maximum ratings¹⁾

$T_j = -40^\circ\text{C}$ to $+150^\circ\text{C}$, all voltages with respect to ground, positive current flowing into pin (unless otherwise specified)

Parameter	Symbol	Values			Unit	Note or test condition	Number
		Min.	Typ.	Max.			
Voltages supply pins							
VS voltage	$V_{S,max}$	-0.3	-	40	V	Load dump	P_1.1.1
VDDP voltage	$V_{DDP,max}$	-0.3	-	5.5	V	-	P_1.1.2
VDDEXT voltage	$V_{DDEXT,max}$	-0.3	-	$V_S + 0.3$	V	-	P_1.1.3
VDDC voltage	$V_{DDC,max}$	-0.3	-	1.6	V	-	P_1.1.4
Voltages high voltage pins							
Voltage at <i>VBAT_SENSE</i> pin	$V_{BAT_SENSE,max}$	-28	-	40	V	²⁾	P_1.1.5
Voltage at <i>HS</i> pin	$V_{HS,max}$	-0.3	-	$V_S + 0.3$	V	-	P_1.1.6
Voltage at <i>LIN</i> pin	$V_{LIN,max}$	-28	-	40	V	-	P_1.1.7
Voltage at <i>MON_X</i> pins	$V_{MON,max}$	-28	-	40	V	²⁾	P_1.1.8
Voltage at <i>LS</i> pin	$V_{LS,max}$	-0.3	-	40	V	Internal clamping structure > 40 V	P_1.1.9
Voltages GPIOs							
Voltage on port pin <i>P0.X</i> , <i>P1.X</i> , <i>P2.X</i> , <i>TMS</i> and <i>RESET</i>	$V_{IO,max}$	-0.3	-	$V_{DDP} + 0.3$	V	$V_{IN} < V_{DDPmax}$	P_1.1.10
Currents							
Injection current in sleep mode on <i>P0.X</i> , <i>P1.X</i> , <i>P2.X</i> , <i>TMS</i> and <i>RESET</i>	I_{xx}	-	-	5	mA	Maximum allowed injection current on single pin or sum of pins in sleep mode and unpowered device	P_1.1.11
Injection current on <i>HS</i>	I_{xLO}	-	-	150	mA	Current flowing into HS pin (back supply in case of short to battery)	P_1.1.12

(table continues...)

29 Electrical characteristics

Table 17 (continued) Absolute maximum ratings¹⁾

$T_j = -40^\circ\text{C}$ to $+150^\circ\text{C}$, all voltages with respect to ground, positive current flowing into pin (unless otherwise specified)

Parameter	Symbol	Values			Unit	Note or test condition	Number
		Min.	Typ.	Max.			
Output current on LS	I_{LS}	-300	-	-	mA	Current flowing out of LS pin, e.g. reverse polarity event (defined in LV124) or ISO Pulse event (defined in ISO 7637-2)	P_1.1.13

Temperatures

Junction temperature	T_j	-40	-	150	$^\circ\text{C}$	-	P_1.1.14
Storage temperature	T_{stg}	-55	-	150	$^\circ\text{C}$	-	P_1.1.15

ESD susceptibility

ESD susceptibility HBM all pins	V_{ESD1}	-2	-	2	kV	JEDEC HBM ³⁾	P_1.1.16
ESD susceptibility HBM pins LIN versus LINGND	V_{ESD3}	-6	-	6	kV	JEDEC HBM ³⁾	P_1.1.17
ESD susceptibility CDM	V_{ESD_CDM}	-500	-	500	V	Charged device model, acc. JEDEC JESD22-C101	P_1.1.18
ESD susceptibility CDM pins 1, 12, 13, 24, 25, 36, 37, 48 (corner pins)	V_{ESD_CDM}	-750	-	750	V	Charged device model, acc. JEDEC JESD22-C101	P_1.1.19

1) Not subject to production test, specified by design.

2) For -28 V, external 3.9 k Ω resistor is required to limit output current.

3) ESD susceptibility, "JEDEC HBM" according to ANSI/ESDA/JEDEC JS001 (1.5 k Ω , 100 pF).

Notes:

1. Stresses above the ones listed here may cause permanent damage to the device. Exposure to absolute maximum rating conditions for extended periods may affect device reliability.
2. Integrated protection functions are designed to prevent IC destruction under fault conditions described in the datasheet. Fault conditions are considered as "outside" normal operating range. Protection functions are not designed for continuous repetitive operation.

29 Electrical characteristics

29.1.2 Functional range

Note: Within the functional range the IC operates as described in the circuit description. The electrical characteristics are specified within the conditions given in the related electrical characteristics table.

Table 18 Functional range

$T_j = -40^\circ\text{C}$ to $+150^\circ\text{C}$, all voltages with respect to ground, positive current flowing into pin (unless otherwise specified)

Parameter	Symbol	Values			Unit	Note or test condition	Number
		Min.	Typ.	Max.			
Supply voltage in active mode	V_{S_AM}	5.5	–	28	V	–	P_1.2.1
Extended supply voltage in active mode - range 1	$V_{S_AM_extended_1}$	28	–	40	V	Functional with parameter deviation ¹⁾	P_1.2.12
Extended supply voltage in active mode with reduced functionality (microcontroller/flash with full operation) - range 2	$V_{S_AM_extended_2}$	3.0	–	5.5	V	Functional with parameter deviation ²⁾	P_1.2.2
Specified supply voltage for LIN/CXPI transceiver - active mode	$V_{S_AM_LIN}$	5.5	–	18	V	Parameter specification	P_1.2.3
Extended supply voltage for monitoring input (MON) - stop and sleep mode	$V_{S_SSM_MON_extend}$	3.6	–	5.5	V	Wake-up functionality ensured	P_1.2.13
Min. supply voltage in stop mode	$V_{S_Stopmin}$	3.0	–	–	V	–	P_1.2.5
Min. supply voltage in sleep mode	$V_{S_Sleepmin}$	3.0	–	–	V	–	P_1.2.6
Supply voltage transients slew rate	$\Delta V_S/\Delta t$	-5	–	5	V/ μs	³⁾	P_1.2.7
Output current on any GPIO	I_{OH}, I_{OL}	-10	–	10	mA	³⁾	P_1.2.8
Output sum current for all GPIO pins	$I_{GPIO,sum}$	-50	–	50	mA	³⁾	P_1.2.9
Operating frequency	f_{sys} ⁴⁾	5	–	25	MHz	³⁾	P_1.2.10
Junction temperature	T_j	-40	–	150	$^\circ\text{C}$	–	P_1.2.11

- 1) This operation voltage range is only allowed for a short duration: $t_{max} \leq 400$ ms.
- 2) Hall-supply, ADC, SPI, UART, NVM, RAM, CPU fully functional and in spec down to 3 V V_S . Actuators (HS, LS) in V_S range from 3 V < V_S < 5.5 V functional but some parameters can be out of spec.
- 3) Not subject to production test, specified by design.
- 4) Function not specified when limits are exceeded.

29 Electrical characteristics

29.1.3 Current consumption

Table 19 Electrical characteristics

$V_S = 5.5\text{ V to }28\text{ V}$, $T_j = -40^\circ\text{C to }+150^\circ\text{C}$, all voltages with respect to ground, positive current flowing into pin (unless otherwise specified). Transceiver module configured for LIN operation

Parameter	Symbol	Values			Unit	Note or test condition	Number
		Min.	Typ.	Max.			
Current consumption at VS pin							
Current consumption in active mode	$I_{V_S_f\text{reduced}}$	–	–	15	mA	$f_{\text{sys}} = 10\text{ MHz}$ $V_S = 13.5\text{ V}$ All digital modules enabled and functional, ADCs converting in sequencer mode, PLL running, no loads on GPIOs, VDDEXT off, LIN in recessive state (no communication), HSx and LSx enabled but off ¹⁾	P_1.3.1
Current consumption in active mode	I_{V_S}	–	14	18	mA	$f_{\text{sys}} = 25\text{ MHz}$ $V_S = 13.5\text{ V}$ All digital modules enabled and functional, ADCs converting in sequencer mode, PLL running, no loads on GPIOs, VDDEXT off, LIN in recessive state (no communication), HSx and LSx enabled but off	P_1.3.22
Current consumption in sleep mode	I_{Sleep}	–	–	20	μA	System in sleep mode, microcontroller not powered, wake capable via LIN and MON; GPIOs open (no loads) or connected to GND: $T_j = -40^\circ\text{C to }25^\circ\text{C}$; $V_S = 13.5\text{ V}$	P_1.3.2
Current consumption in sleep mode (extended temperature range)	$I_{\text{Sleep}(T_{\text{ext end}})}$	–	–	35	μA	System in sleep mode, microcontroller not powered, wake capable via LIN and MON; GPIOs open (no loads) or connected to GND: $T_j = 25^\circ\text{C to }85^\circ\text{C}$; $V_S = 13.5\text{ V}$	P_1.3.3

(table continues...)

29 Electrical characteristics

Table 19 (continued) Electrical characteristics

$V_S = 5.5\text{ V to }28\text{ V}$, $T_j = -40^\circ\text{C to }+150^\circ\text{C}$, all voltages with respect to ground, positive current flowing into pin (unless otherwise specified). Transceiver module configured for LIN operation

Parameter	Symbol	Values			Unit	Note or test condition	Number
		Min.	Typ.	Max.			
Current consumption in sleep mode (extended voltage and temperature range)	$I_{\text{Sleep}(V_{T_e}\text{xtend})}$	–	–	35	μA	System in sleep mode, microcontroller not powered, wake capable via LIN and MON; GPIOs open (no loads) or connected to GND: $T_j = -40^\circ\text{C to }85^\circ\text{C}$; $V_S = 5.5\text{ V to }18\text{ V}$	P_1.3.4
Current consumption in sleep mode (extended voltage and temperature range 2)	$I_{\text{Sleep}(V_{T_e}\text{xtend}2)}$	–	–	40	μA	System in sleep mode, microcontroller not powered, wake capable via LIN and MON; GPIOs open (no loads) or connected to GND: $T_j = -40^\circ\text{C to }85^\circ\text{C}$; $V_S = 3\text{ V to }28\text{ V}$	P_1.3.7
Current consumption in sleep mode with cyclic wake	I_{Cyclic}	–	–	20	μA	$T_j = -40^\circ\text{C to }25^\circ\text{C}$; $V_S = 13.5\text{ V}$; during sleep period	P_1.3.5
Current consumption in sleep mode with cyclic wake (extended temperature range)	$I_{\text{Cyclic}(T_{\text{ext}}\text{end})}$	–	–	35	μA	$T_j = 25^\circ\text{C to }85^\circ\text{C}$; $V_S = 13.5\text{ V}$; during sleep period	P_1.3.6
Current consumption in stop mode	I_{stop}	–	90	140	μA	System in stop mode, microcontroller not clocked, wake capable via LIN and MON; GPIOs open (no loads) or connected to GND; GPIOs are set to PD enabled in test condition $T_j = -40^\circ\text{C to }85^\circ\text{C}$	P_1.3.19

(table continues...)

29 Electrical characteristics

Table 19 (continued) Electrical characteristics

$V_S = 5.5\text{ V to }28\text{ V}$, $T_j = -40^\circ\text{C to }+150^\circ\text{C}$, all voltages with respect to ground, positive current flowing into pin (unless otherwise specified). Transceiver module configured for LIN operation

Parameter	Symbol	Values			Unit	Note or test condition	Number
		Min.	Typ.	Max.			
Current consumption in stop mode	$I_{\text{stop_V_exte}}^{\text{nd}}$	–	3.5	4.0	mA	System in stop mode, microcontroller not clocked, wake capable via LIN and MON; GPIOs open (no loads) or connected to GND; $T_j = -40^\circ\text{C to }85^\circ\text{C}$; $V_S = 3\text{ V}$	P_1.3.21
Current consumption in stop mode with cyclic sense	$I_{\text{stop_CS}}$	–	85	140	μA	System in stop mode (during stop period), microcontroller not clocked, wake capable via LIN and MON; VDDEXT off; High Side off; GPIOs open (no loads) or connected to GND or VDDP; $T_j = -40^\circ\text{C to }85^\circ\text{C}$; $V_S = 5.5\text{ V to }28\text{ V}$	P_1.3.20

1) Not subject to production test, specified by design.

29.1.4 Thermal resistance

Table 20 Thermal resistance

Parameter	Symbol	Values			Unit	Note or test condition	Number
		Min.	Typ.	Max.			
Junction to case	$R_{\text{th(JC)}}$	–	6	–	K/W	1) Measured to exposed pad	P_1.4.1
Junction to ambient	$R_{\text{th(JA)}}$	–	33	–	K/W	2)	P_1.4.2

1) Not subject to production test, specified by design.

2) According to Jedec JESD51-2,-5,-7 at natural convection on FR4 2s2p board . Board: $76.2 \times 114.3 \times 1.5\text{ mm}^3$ with 2 inner copper layers (35 μm thick), with thermal via array under the exposed pad contacting the first inner copper layer and 300 mm^2 cooling area on the bottom layer (70 μm).

29.1.5 Timing characteristics

The transition times between the system modes are specified here. Generally the timings are defined from the time when the corresponding bits in register PMCON0 are set until the sequence is terminated.

29 Electrical characteristics

Table 21 System timing¹⁾

$V_S = 5.5\text{ V to }28\text{ V}$, $T_j = -40^\circ\text{C to }+150^\circ\text{C}$, all voltages with respect to ground, positive current flowing into pin (unless otherwise specified)

Parameter	Symbol	Values			Unit	Note or test condition	Number
		Min.	Typ.	Max.			
Wake-up over battery	t_{start}	–	–	1	ms	Battery ramp-up till MCU reset is released; $V_S > 3\text{ V}$ and RESET = '1'	P_1.5.1
Sleep-exit	$t_{\text{sleep - exit}}$	–	–	2.4	ms	Rising/falling edge of any wake-up signal (TRX, MON) till MCU software running	P_1.5.2
Sleep-entry	$t_{\text{sleep - entry}}$	–	–	330	μs	²⁾	P_1.5.3

1) Not subject to production test, specified by design.

2) Wake events during sleep-entry are stored and lead to wake-up after sleep mode is reached.

29 Electrical characteristics

29.2 Power management unit (PMU)

This chapter includes all electrical characteristics of the power management unit.

29.2.1 PMU input voltage VS

Table 22 Electrical characteristics

$V_S = 5.5\text{ V to }28\text{ V}$, $T_j = -40^\circ\text{C to }+150^\circ\text{C}$, all voltages with respect to ground, positive current flowing into pin (unless otherwise specified)

Parameter	Symbol	Values			Unit	Note or test condition	Number
		Min.	Typ.	Max.			
Required decoupling capacitance	C_{VS1}	0.1	–	–	μF	¹⁾ ESR < 1 Ω	P_2.1.12
Required buffer capacitance for stability (load jumps)	C_{VS2}	10	–	–	μF	²⁾	P_2.1.13

1) Only min. value is tested.

2) Not subject to production test, specified by design.

29.2.2 PMU I/O supply parameters VDDP

Table 23 Electrical characteristics

$V_S = 5.5\text{ V to }28\text{ V}$, $T_j = -40^\circ\text{C to }+150^\circ\text{C}$, all voltages with respect to ground, positive current flowing into pin (unless otherwise specified)¹⁾

Parameter	Symbol	Values			Unit	Note or test condition	Number
		Min.	Typ.	Max.			
Specified output current	I_{VDDP}	0	–	50	mA	²⁾	P_2.1.1
Required decoupling capacitance	C_{VDDP1}	0.47	–	–	μF	^{3) 4)} ESR < 1 Ω	P_2.1.2
Required buffer capacitance for stability (load jumps)	C_{VDDP2}	0.47	–	1	μF	^{4) 5)}	P_2.1.3
Output voltage including line and load regulation at active mode	V_{DDPOUT}	4.9	5.0	5.1	V	⁶⁾ $I_{load} < 90\text{ mA}$; $V_S > 5.5\text{ V}$	P_2.1.4
Output voltage including line and load regulation at stop mode	$V_{DDPOUTSTOP}$	4.5	5.0	5.25	V	⁶⁾ I_{load} is only internal; $V_S > 5.5\text{ V}$	P_2.1.5
Output drop	$V_{S\ VDDPout}$	–	50	+400	mV	⁷⁾ $I_{VDDP} = 50\text{ mA}$; $V_S = 3\text{ V}$;	P_2.1.6
Load regulation	$V_{VDDPLOR}$	-50	–	50	mV	2 ... 90 mA; $C = C_{VDDP1} + C_{VDDP2}$	P_2.1.7
Line regulation	$V_{VDDPLIR}$	-50	–	50	mV	$V_S = 5.5 \dots 28\text{ V}$	P_2.1.8

(table continues...)

29 Electrical characteristics

Table 23 (continued) Electrical characteristics

$V_S = 5.5\text{ V to }28\text{ V}$, $T_j = -40^\circ\text{C to }+150^\circ\text{C}$, all voltages with respect to ground, positive current flowing into pin (unless otherwise specified)¹⁾

Parameter	Symbol	Values			Unit	Note or test condition	Number
		Min.	Typ.	Max.			
Overvoltage detection	V_{DDPOV}	5.14	–	5.4	V	$V_S > 5.5\text{ V}$; Overvoltage leads to SUPPLY_NMI	P_2.1.9
Undervoltage reset	V_{DDPUV}	2.55	2.7	2.8	V	–	P_2.1.10
Overcurrent diagnostic	I_{VDDPOC}	90	–	200	mA	Current including VDDC current consumption	P_2.1.11

- 1) Currents used in this table are positive but flowing out the pin VDDP.
- 2) Specified output current for port supply and additional other external loads connected to VDDP, excluding on-chip current consumption.
- 3) Only min. value is tested.
- 4) The total capacitance on VDDP must not exceed 2,2 μF .
- 5) Not subject to production test, specified by design.
- 6) Load current includes internal supply.
- 7) Output drop for I_{VDDP} plus internal supply.

29 Electrical characteristics

29.2.3 PMU core supply parameters VDDC

Table 24 Electrical characteristics

$V_S = 5.5 \text{ V to } 28 \text{ V}$, $T_j = -40^\circ\text{C to } +150^\circ\text{C}$, all voltages with respect to ground, positive current flowing into pin (unless otherwise specified)

Parameter	Symbol	Values			Unit	Note or test condition	Number
		Min.	Typ.	Max.			
Required decoupling capacitance	C_{VDDC1}	0.1	–	–	μF	¹⁾ ESR < 1 Ω	P_2.2.1
Required buffer capacitance for stability (load jumps)	C_{VDDC2}	0.33	–	1	μF	²⁾	P_2.2.2
Output voltage including line regulation at active mode/stop mode	V_{DDCOUT}	1.44	1.5	1.56	V	$I_{load} < 40 \text{ mA}$; with setting of VDDC output voltage to 1.5 V in stop mode	P_2.2.3
Load regulation	V_{DDCLOR}	-50	–	50	mV	2 ... 40 mA; $C = C_{VDDC1} + C_{VDDC2}$	P_2.2.4
Line regulation	V_{DDCLIR}	-25	–	25	mV	$V_S = 5.5 \dots 28 \text{ V}$	P_2.2.5
Overvoltage detection	V_{DDCOV}	1.58	–	1.68	V	Overvoltage leads to SUPPLY_NMI	P_2.2.6
Undervoltage reset	V_{DDVUV}	1.10	–	1.19	V	–	P_2.2.7
Overcurrent diagnostic	I_{VDDCOC}	40	–	80	mA	–	P_2.2.8

1) Only min. value is tested.

2) Not subject to production test, specified by design.

29 Electrical characteristics

29.2.4 VDDEXT voltage regulator 5.0 V

Table 25 Electrical characteristics

$V_S = 5.5\text{ V to }28\text{ V}$, $T_j = -40^\circ\text{C to }+150^\circ\text{C}$, all voltages with respect to ground, positive current flowing into pin (unless otherwise specified)¹⁾

Parameter	Symbol	Values			Unit	Note or test condition	Number
		Min.	Typ.	Max.			
VDDEXT regulator active mode							
Specified output current	I_{VDDEXT}	0	–	20	mA	Current flowing out of pin VDDEXT	P_2.3.1
Required decoupling capacitance	$C_{VDDEXT1}$	330	–	1000	nF	²⁾ ESR < 1 Ω	P_2.3.2
Required buffer capacitance for stability (load jumps)	$C_{VDDEXT2}$	100	–	1000	nF	³⁾	P_2.3.3
Output voltage including line and load regulation	V_{DDEXT}	4.9	5.0	5.1	V	$I_{load} < 20\text{ mA}$; $V_S \geq 5.5\text{ V}$	P_2.3.4
Output drop	$V_S - V_{DDEXT}$		50	+400	mV	$I_{load} < 20\text{ mA}$; $3\text{ V} < V_S < 5.0\text{ V}$	P_2.3.5
Load regulation	$V_{DDEXTLOR}$	-80	–	20	mV	0.01 ... 20 mA; $C = C_{VDDEXT1} + C_{VDDEXT2}$; $V_S \geq 5.5\text{ V}$	P_2.3.6
Line regulation	$V_{DDEXTLIR}$	-50	–	50	mV	$V_S = 5.5 \dots 28\text{ V}$	P_2.3.7
Power supply ripple rejection	$P_{SSRVDDEXT}$	50	–	–	dB	³⁾ $V_S = 13.5\text{ V}$; $f = 0 \dots 1\text{ KHz}$; $V_r = 2\text{ Vpp}$; $0 \dots 20\text{ mA}$	P_2.3.8
Undervoltage shutdown	$V_{VDDEXTUV}$	1.55	1.9	2.2	V	⁴⁾	P_2.3.9
Overcurrent limitation	$I_{VDDEXTOC}$	100	250	380	mA	³⁾	P_2.3.10
VDDEXT output discharge resistance	R_{VDDEXT_DISCHG}	16	20	24	kΩ	–	P_2.3.11

VDDEXT regulator low current mode

Specified output current	I_{VDDEXT_LCM}	0	–	5	mA	–	P_2.3.28
Output voltage including line and load regulation - load 1	V_{DDEXT_LCM1}	4.6	5.0	5.1	V	$I_{load} \leq 5\text{ mA}$; $V_S \geq 5.5\text{ V}$	P_2.3.29
Output drop - load 1	$V_S - V_{DDEXT_LCM1}$	–	50	+300	mV	$I_{load} \leq 5\text{ mA}$; $3\text{ V} < V_S \leq 5\text{ V}$; $C = C_{VDDEXT1} + C_{VDDEXT2}$	P_2.3.30

(table continues...)

29 Electrical characteristics

Table 25 (continued) Electrical characteristics

$V_S = 5.5\text{ V to }28\text{ V}$, $T_j = -40^\circ\text{C to }+150^\circ\text{C}$, all voltages with respect to ground, positive current flowing into pin (unless otherwise specified)¹⁾

Parameter	Symbol	Values			Unit	Note or test condition	Number
		Min.	Typ.	Max.			
Load regulation - load 1	$V_{\text{DDEXTLOR_L}}$ CM1	-250	–	250	mV	0 ... 5 mA; $C = C_{\text{VDDEXT1}} + C_{\text{VDDEXT2}}$; $V_S \geq 5.5\text{ V}$	P_2.3.31
Line regulation - load 1	$V_{\text{VDDEXTLIR_L}}$ CM1	-300	–	300	mV	$I_{\text{load}} \leq 5\text{ mA}$; $V_S = 5.5 \dots 28\text{ V}$	P_2.3.32
Power supply ripple rejection	$P_{\text{SSRVDEXT_LCM}}$	50	–	–	dB	³⁾ $V_S = 13.5\text{ V}$; $f = 0 \dots 1\text{ KHz}$; $V_r = 2\text{ Vpp}$; 0 ... 5 mA	P_2.3.33

- 1) Currents used in this table are positive but flowing out the pin VDDEXT.
2) Only min. value is tested.
3) Not subject to production test, specified by design.
4) When condition is met, the bit VDDEXT_CTRL.VDDEXT_UV_IS will be set.

29 Electrical characteristics

29.2.5 VPRE voltage regulator (PMU subblock) parameters

The PMU VPRE regulator acts as a supply of VDDP and VDDC voltage regulators.

Table 26 Functional range

Parameter	Symbol	Values			Unit	Note or Test Condition	Number
		Min.	Typ.	Max.			
Specified output current	I_{VPRE}	-	-	90	mA	1)	P_2.4.1

1) Not subject to production test, specified by design.

29.2.5.1 Load sharing of VPRE regulator

The figure below shows the load sharing concept of VPRE regulator.

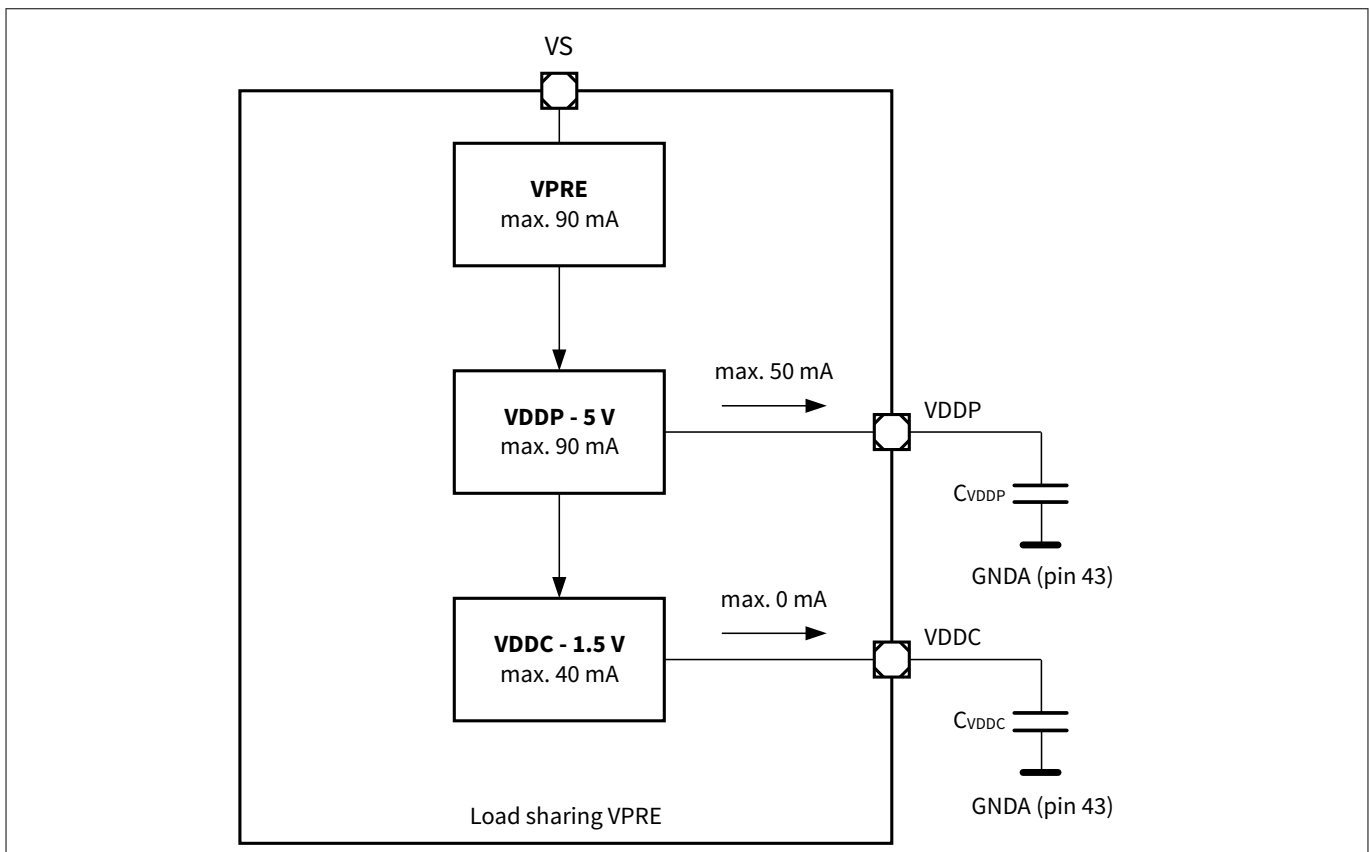

Figure 37 Load sharing of VPRE regulator

29 Electrical characteristics

29.2.6 Power down voltage regulator (PMU subblock) parameters

The PMU power down voltage regulator consists of two subblocks:

- Power down pre regulator: VDD5VPD
- Power down core regulator: VDD1V5_PD (Supply used for GPUDATAxy registers)

Both regulators are used as purely internal supplies. The following table contains all relevant parameters.

Table 27 Functional range

Parameter	Symbol	Values			Unit	Note or test condition	Number
		Min.	Typ.	Max.			
Power-on reset threshold	$V_{DD1V5_PD_RSTTH}$	1.2	–	1.5	V	¹⁾ I_{load} = internal load connected to VDD1V5_PD	P_2.5.1

¹⁾ Not subject to production test, specified by design.

29 Electrical characteristics

29.3 System clocks

29.3.1 Electrical characteristics oscillators and PLL

Table 28 Electrical characteristics system clocks

$V_S = 5.5\text{ V to }28\text{ V}$, $T_j = -40^\circ\text{C to }+150^\circ\text{C}$, all voltages with respect to ground, positive current flowing into pin (unless otherwise specified)

Parameter	Symbol	Values			Unit	Note or test condition	Number
		Min.	Typ.	Max.			
PMU oscillators (power management unit)							
Frequency of LP_CLK	f_{LP_CLK}	17	20	23	MHz	This clock is used at start-up and can be used in case the PLL fails	P_3.1.1
Frequency of LP_CLK2	f_{LP_CLK2}	70	100	130	kHz	This clock is used for cyclic wake	P_3.1.2
CGU oscillator (clock generation unit microcontroller)							
Short term frequency deviation ¹⁾	f_{TRIMST}	-0.4	–	+0.4	%	Within any 100 ms, e.g. after synchronization to a LIN frame (includes PLL accumulated jitter value). Assumption: T_j is varying < 30°C.	P_3.1.3
Absolute accuracy	$f_{TRIMABSA}$	-1.49	–	+1.49	%	Including temperature and lifetime drift and supply variation	P_3.1.4
CGU-OSC start-up time	t_{OSC}	–	–	10	µs	²⁾ Start-up time OSC from sleep mode, power supply stable	P_3.1.5
PLL (clock generation unit microcontroller)²⁾							
VCO reference frequency range	f_{REF}	0.8	1	1.25	MHz	–	P_3.1.25
VCO frequency (tuning) range	f_{VCO}	48	–	160	MHz	–	P_3.1.21
Input frequency range	f_{OSC}	4	–	40	MHz	^{3) 4)} External input clock mode	P_3.1.6
XTAL1 input freq. range	f_{OSCHP}	4	–	16	MHz	³⁾ External crystal mode	P_3.1.23
Output freq. range	f_{PLL}	15	–	40	MHz	^{3) 5)}	P_3.1.7
Free-running frequency	$f_{VCOfree}$	–	34	–	MHz	–	P_3.1.24
Input clock high/low time	$t_{high/low}$	10	–	–	ns	–	P_3.1.8

(table continues...)

29 Electrical characteristics

Table 28 (continued) Electrical characteristics system clocks

$V_S = 5.5\text{ V to }28\text{ V}$, $T_j = -40^\circ\text{C to }+150^\circ\text{C}$, all voltages with respect to ground, positive current flowing into pin (unless otherwise specified)

Parameter	Symbol	Values			Unit	Note or test condition	Number
		Min.	Typ.	Max.			
Peak period jitter	t_{jp}	-500	-	500	ps	For K = 2; this parameter value is only valid with the combination of an external quartz oscillator (e.g. 5 MHz)	P_3.1.9
Accumulated jitter with external oscillator	j_{acc_ext}	-	-	5	ns	For K = 2; this parameter value is only valid with the combination of an external quartz oscillator (e.g. 5 MHz).	P_3.1.10
Lock-in time	t_L	-	-	260	μs	This parameter represents the duration from module power-on to assertion of lock signal	P_3.1.11

- 1) The typical oscillator frequency is 40 MHz
- 2) Not subject to production test, specified by design.
- 3) Specified limits for f_{VCO} and f_{REF} need to be fulfilled, restrictions to PDIV, NDIV, K2DIV settings apply.
- 4) Above 24 MHz the hysteresis of the OSC_HP module needs to be switched off (see register SCU_XTAL_CTRL).
- 5) The parameter P_3.1.7 specifies the limits for the output frequency range without taking into account the absolute accuracy of the internal oscillator.

29.3.2 External clock parameters XTAL1, XTAL2

Table 29 Functional range

$V_S = 5.5\text{ V to }28\text{ V}$, $T_j = -40^\circ\text{C to }+150^\circ\text{C}$, all voltages with respect to ground, positive current flowing into pin (unless otherwise specified)¹⁾

Parameter	Symbol	Values			Unit	Note or test condition	Number
		Min.	Typ.	Max.			
Input voltage range limits for signal on XTAL1	V_{IX1_SR}	$-1.7 + V_{DDC}$	-	1.7	V	²⁾	P_3.2.1
Input voltage (amplitude) on XTAL1	V_{AX1_SR}	0.6	-	-	V	³⁾ Peak-to-peak voltage	P_3.2.2
XTAL1 input current	I_{IL}	-	-	± 20	μA	$0\text{ V} < V_{IN} < V_{DDI}$	P_3.2.3
Oscillator frequency - external input clock mode	f_{OSC_EXT}	4	-	16	MHz	⁴⁾ Clock signal	P_3.2.4
Oscillator frequency - external crystal mode	f_{OSC_XTAL}	4	-	16	MHz	Crystal or resonator	P_3.2.5
High time	t_{1_VCOBYP}	6	-	-	ns	^{5) 6)}	P_3.2.6

(table continues...)

29 Electrical characteristics

Table 29 (continued) Functional range

$V_S = 5.5\text{ V to }28\text{ V}$, $T_j = -40^\circ\text{C to }+150^\circ\text{C}$, all voltages with respect to ground, positive current flowing into pin (unless otherwise specified)¹⁾

Parameter	Symbol	Values			Unit	Note or test condition	Number
		Min.	Typ.	Max.			
Low time	t_{2_VCOBYP}	6	–	–	ns	5) 6)	P_3.2.7
Rise time	t_{3_VCOBYP}	–	8	8	ns	5) 6)	P_3.2.8
Fall time	t_{4_VCOBYP}	–	8	8	ns	5) 6)	P_3.2.9
High time	t_{1_PLLNM}	12	–	–	ns	6) 7)	P_3.2.10
Low time	t_{2_PLLNM}	12	–	–	ns	6) 7)	P_3.2.11
Rise time	t_{3_PLLNM}	–	7	7	ns	6) 7)	P_3.2.12
Fall time	t_{4_PLLNM}	–	7	7	ns	6) 7)	P_3.2.13

- 1) Not subject to production test, specified by design.
- 2) Overload conditions must not occur on pin XTAL1.
- 3) The amplitude voltage V_{AX1} refers to the offset voltage V_{OFF} . This offset voltage must be stable during the operation and the resulting voltage peaks must remain within the limits defined by V_{IX1} .
- 4) Valid for rectangular full-swing input signals.
- 5) This performance is only valid for prescaler mode (VCO bypass mode).
- 6) Tested with rectangular signal with $V_{IN_Low} = 0\text{ V}$ to $V_{IN_High} = V_{DDC}$.
- 7) This performance is only valid for PLL normal mode.

29 Electrical characteristics

29.4 Flash parameters

This chapter includes the parameters for the 64 Kbyte embedded flash module.

29.4.1 Flash characteristics

Table 30 Flash characteristics¹⁾

$V_S = 5.5\text{ V to }28\text{ V}$, $T_j = -40^\circ\text{C to }+150^\circ\text{C}$, all voltages with respect to ground, positive current flowing into pin (unless otherwise specified)

Parameter	Symbol	Values			Unit	Note or Test Condition	Number
		Min.	Typ.	Max.			
Programming time per 128 byte page	t_{PR}	–	3 ²⁾	3.5	ms	$3\text{ V} < V_S < 28\text{ V}$	P_4.1.1
Erase time per sector/page	t_{ER}	–	4 ²⁾	4.5	ms	$3\text{ V} < V_S < 28\text{ V}$	P_4.1.2
Data retention time	t_{RET}	20	–	–	years	1,000 erase / program cycles	P_4.1.3
Data retention time	t_{RET}	50	–	–	years	1,000 erase / program cycles $T_j = 30^\circ\text{C}$ ³⁾	P_4.1.4
Flash erase endurance for user sectors	N_{ER}	30	–	–	kcycles	Data retention time 5 years	P_4.1.5
Flash erase endurance for security pages ⁴⁾	N_{SEC}	10	–	–	cycles	Data retention time 20 years	P_4.1.6
Drain disturb limit	N_{DD}	32	–	–	kcycles	⁵⁾	P_4.1.7

- 1) Not subject for production test, specified by design.
- 2) Programming and erase times depend on the internal flash clock source. The control state machine needs a few system clock cycles. The requirement is only relevant for extremely low system frequencies.
- 3) Derived by extrapolation of lifetime tests.
- 4) Temperature: 25°C.
- 5) This parameter limits the number of subsequent programming operations within a physical sector without a given page in this sector being (re-)programmed. The drain disturb limit is applicable if word line erase is used repeatedly. For normal sector erase/program cycles this limit will not be violated. For data sectors the integrated EEPROM emulation firmware routines handle this limit automatically, for word line erases in code sectors (without EEPROM emulation) it is recommended to execute a software based refresh, which may make use of the integrated random number generator NVMBRNG to statistically start a refresh.

29 Electrical characteristics

29.5 Parallel ports (GPIO)

29.5.1 Description of keep and force current

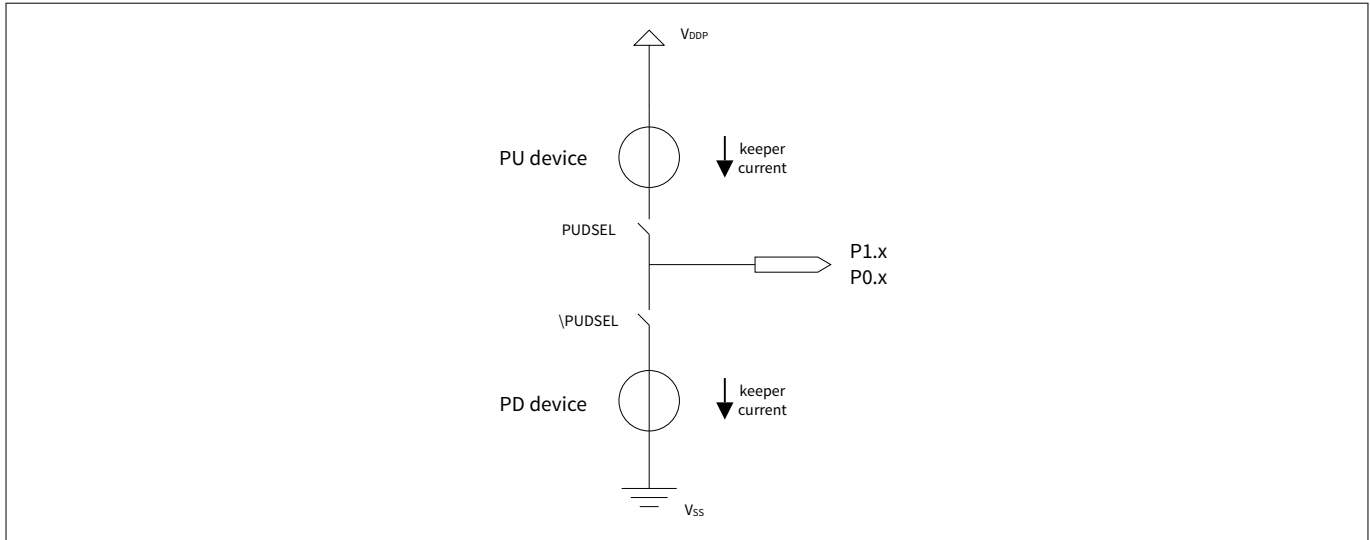

Figure 38 Pull-up/down device

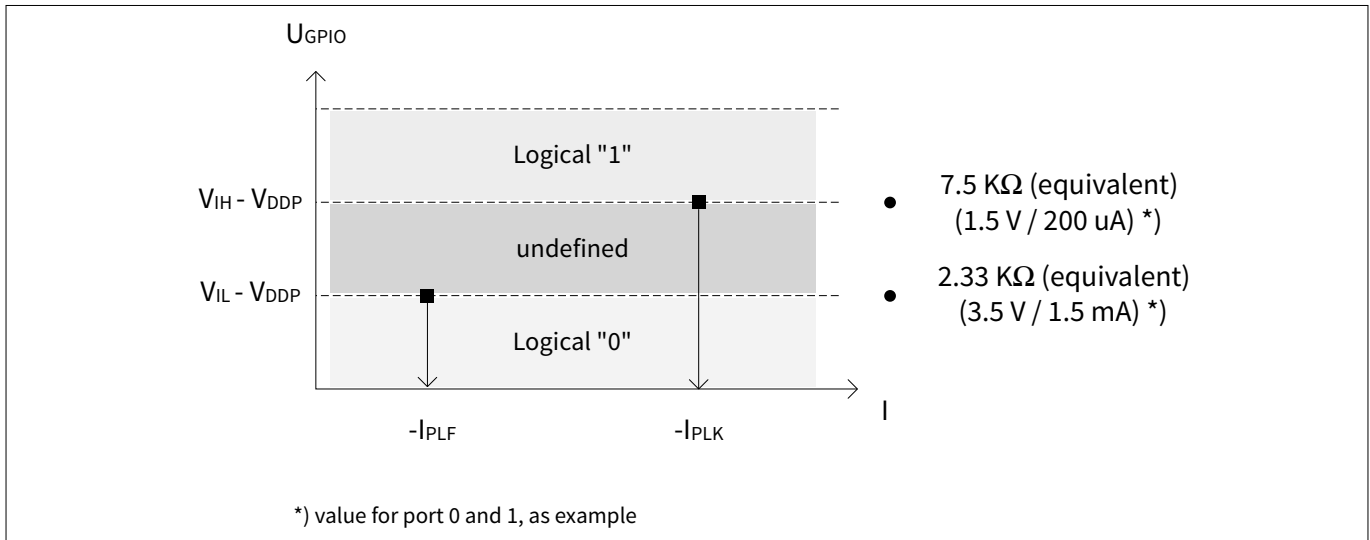

Figure 39 Pull-up keep and forced current

29 Electrical characteristics

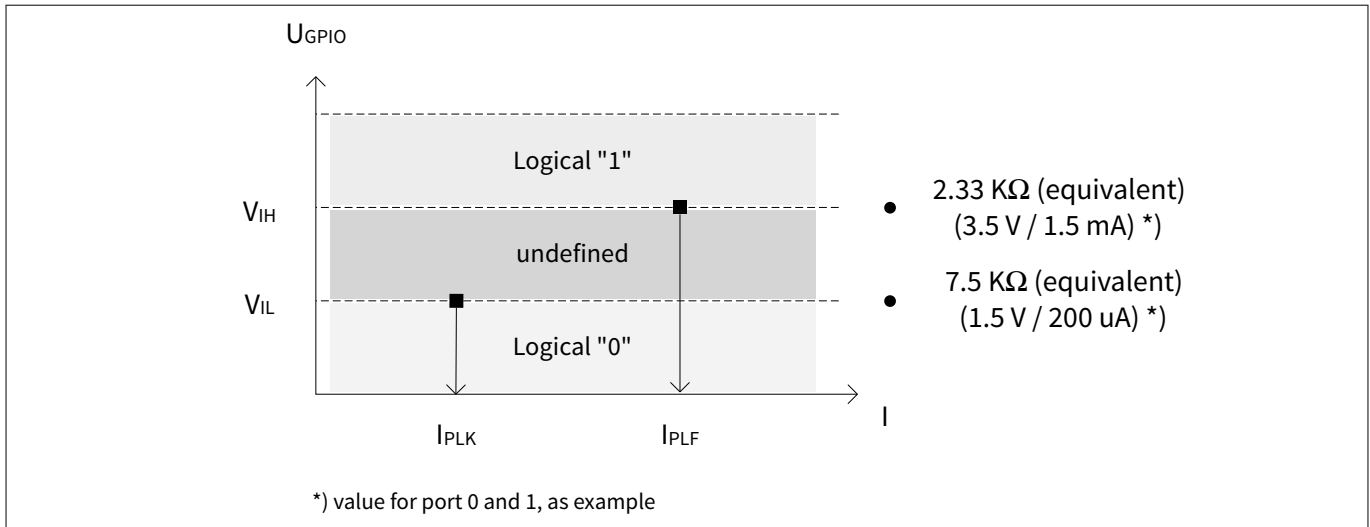

Figure 40 Pull-down keep and force current

29.5.2 DC parameters port 0, port 1, TMS, reset

Table 31 DC characteristics port 0, port 1

$V_S = 5.5\text{ V to }28\text{ V}$, $T_j = -40^\circ\text{C to }+150^\circ\text{C}$, all voltages with respect to ground, positive current flowing into pin (unless otherwise specified)

Parameter	Symbol	Values			Unit	Note or test condition	Number
		Min.	Typ.	Max.			
Input low voltage	V_{IL}	-0.3	-	$0.3 \times V_{DDP}$	V	¹⁾ $4.5\text{ V} \leq V_{DDP} \leq 5.5\text{ V}$	P_5.2.1
Input low voltage	V_{IL_extend}	-0.3	$0.42 \times V_{DDP}$	-	V	²⁾ $2.6\text{ V} \leq V_{DDP} < 4.5\text{ V}$	P_5.2.14
Input high voltage	V_{IH}	$0.7 \times V_{DDP}$	-	$V_{DDP} + 0.3$	V	¹⁾ $4.5\text{ V} \leq V_{DDP} \leq 5.5\text{ V}$	P_5.2.2
Input high voltage	V_{IH_extend}	-	$0.52 \times V_{DDP}$	$V_{DDP} + 0.3$	V	²⁾ $2.6\text{ V} \leq V_{DDP} < 4.5\text{ V}$	P_5.2.15
Input hysteresis	HYS	$0.11 \times V_{DDP}$	-	-	V	²⁾ $4.5\text{ V} \leq V_{DDP} \leq 5.5\text{ V}$; Series resistance = $0\ \Omega$	P_5.2.3
Input hysteresis	HYS_{extend}	-	$0.09 \times V_{DDP}$	-	V	²⁾ $2.6\text{ V} \leq V_{DDP} < 4.5\text{ V}$; Series resistance = $0\ \Omega$	P_5.2.16
Output low voltage	V_{OL}	-	-	1.0	V	^{3) 4)} $I_{OL} \leq I_{OLmax}$	P_5.2.4
Output low voltage	V_{OL}	-	-	0.4	V	^{3) 5)} $I_{OL} \leq I_{OLnom}$	P_5.2.5
Output high voltage	V_{OH}	$V_{DDP} - 1.0$	-	-	V	^{3) 4)} $I_{OH} \geq I_{OHmax}$	P_5.2.6
Output high voltage	V_{OH}	$V_{DDP} - 0.4$	-	-	V	^{3) 5)} $I_{OH} \geq I_{OHnom}$	P_5.2.7

(table continues...)

29 Electrical characteristics

Table 31 (continued) DC characteristics port 0, port 1

$V_S = 5.5\text{ V to }28\text{ V}$, $T_j = -40^\circ\text{C to }+150^\circ\text{C}$, all voltages with respect to ground, positive current flowing into pin (unless otherwise specified)

Parameter	Symbol	Values			Unit	Note or test condition	Number
		Min.	Typ.	Max.			
Input leakage current	I_{OZ2}	-5	-	+5	μA	⁶⁾ $T_j \leq 85^\circ\text{C}$, $0.45\text{ V} < V_{IN} < V_{DDP}$	P_5.2.8
Input leakage current	I_{OZ2}	-15	-	+15	μA	$T_j \leq 150^\circ\text{C}$, $0.45\text{ V} < V_{IN} < V_{DDP}$	P_5.2.9
Pull level keep current ⁷⁾	I_{PLK}	-	-	± 200	μA	⁸⁾ $V_{PIN} \geq V_{IH}$ (up) $V_{PIN} \leq V_{IL}$ (dn)	P_5.2.10
Pull level force current ⁷⁾	I_{PLF}	± 1.5	-	-	mA	⁸⁾ $V_{PIN} \geq V_{IL}$ (up) $V_{PIN} \leq V_{IH}$ (dn)	P_5.2.11
Pin capacitance	C_{IO}	-	-	10	pF	²⁾	P_5.2.12

Reset pin timing

Reset pin input filter time	$T_{\text{filt_RESET}}$	-	5	-	μs	⁹⁾	P_5.2.13
-----------------------------	--------------------------	---	---	---	---------------	---------------	----------

- 1) Tested at $V_{DDP} = 5\text{ V}$, specified for $2.55\text{ V} < V_{DDP} < 5.1\text{ V}$.
- 2) Not subject to production test, specified by design.
- 3) The maximum deliverable output current of a port driver depends on the selected output driver mode. The limit for pin groups must be respected.
- 4) Tested at $2.55\text{ V} < V_{DDP} < 5.1\text{ V}$, $I_{OL} = 4\text{ mA}$, $I_{OH} = -4\text{ mA}$, specified for $2.7\text{ V} < V_{DDP} < 5.1\text{ V}$.
- 5) As a rule, with decreasing output current the output levels approach the respective supply level ($V_{OL} \rightarrow GND$, $V_{OH} \rightarrow V_{DDP}$). Tested at $2.55\text{ V} < V_{DDP} < 5.1\text{ V}$, $I_{OL} = 1\text{ mA}$, $I_{OH} = -1\text{ mA}$.
- 6) The given values are worst-case values. In production test, this leakage current is only tested at 125°C ; other values are ensured by correlation. For derating, please refer to the following descriptions: Leakage derating depending on temperature ($T_j =$ junction temperature [$^\circ\text{C}$]): $I_{OZ} = 0.05 \times e^{(1.5 + 0.028 \times T_j)}$ [μA]. For example, at a temperature of 95°C the resulting leakage current is $3.2\ \mu\text{A}$. Leakage derating depending on voltage level ($DV = V_{DDP} - V_{PIN}$ [V]): $I_{OZ} = I_{OZ\text{tempmax}} - (1.6 \times DV)$ [μA]. This voltage derating formula is an approximation which applies for maximum temperature.
- 7) Negative current is representing pullup; positive current is representing pulldown.
- 8) Keep current: Limit the current through this pin to the indicated value so that the enabled pull device can keep the default pin level: $V_{PIN} \geq V_{IH}$ for a pull-up; $V_{PIN} \leq V_{IL}$ for a pull-down.
 Force current: Drive the indicated minimum current through this pin to change the default pin level driven by the enabled pull device: $V_{PIN} \leq V_{IL}$ for a pull-up; $V_{PIN} \geq V_{IH}$ for a pull-down.
 These values apply to the fixed pull-devices in dedicated pins and to the user-selectable pull-devices in general purpose IO pins.
- 9) This filter time and its variation is derived from the time base $t_{LP_CLK} = 1 / f_{LP_CLK}$.

Note: *Operating conditions apply.
 Keeping signal levels within the limits specified in this table ensures operation without overload conditions. For signal levels outside these specifications, also refer to the specification of the overload current I_{OV} .*

29 Electrical characteristics

Table 32 Current limits for port output drivers¹⁾

Port output driver mode	Maximum output current (I_{OLmax} , - I_{OHmax})		Output current (I_{OLnom} , - I_{OHnom})		Number
	$V_{DDP} \geq 4.5\text{ V}$	$2.55\text{ V} < V_{DDP} < 4.5\text{ V}$	$V_{DDP} \geq 4.5\text{ V}$	$2.55\text{ V} < V_{DDP} < 4.5\text{ V}$	
Strong driver	5 mA	3 mA	1.6 mA	1.0 mA	P_5.2.20
Medium driver	3 mA	1.8 mA	1.0 mA	0.8 mA	P_5.2.21
Weak driver	0.5 mA	0.3 mA	0.25 mA	0.15 mA	P_5.2.22

1) Not subject to production test, specified by design.

29.5.3 DC parameters port 2

These parameters apply to the IO voltage range, $2.55\text{ V} \leq V_{DDP} \leq 5.5\text{ V}$.

Note: Operating conditions apply.

Keeping signal levels within the limits specified in this table ensures operation without overload conditions. For signal levels outside these specifications, also refer to the specification of the overload current I_{OV} .

Table 33 DC characteristics port 2

$V_S = 5.5\text{ V}$ to 28 V , $T_j = -40^\circ\text{C}$ to $+150^\circ\text{C}$, all voltages with respect to ground, positive current flowing into pin (unless otherwise specified)

Parameter	Symbol	Values			Unit	Note or test condition	Number
		Min.	Typ.	Max.			
Input low voltage	V_{IL_P2}	-0.3	-	$0.3 \times V_{DDP}$	V	¹⁾ $4.5\text{ V} \leq V_{DDP} \leq 5.5\text{ V}$	P_5.3.1
Input low voltage	$V_{IL_P2_ext}$ end	-0.3	$0.42 \times V_{DDP}$	-	V	²⁾ $2.6\text{ V} \leq V_{DDP} < 4.5\text{ V}$	P_5.3.8
Input high voltage	V_{IH_P2}	$0.7 \times V_{DDP}$	-	$V_{DDP} + 0.3$	V	¹⁾ $4.5\text{ V} \leq V_{DDP} \leq 5.5\text{ V}$	P_5.3.2
Input high voltage	$V_{IH_P2_ext}$ end	-	$0.52 \times V_{DDP}$	$V_{DDP} + 0.3$	V	²⁾ $2.6\text{ V} \leq V_{DDP} < 4.5\text{ V}$	P_5.3.9
Input hysteresis	HYS_{P2}	$0.11 \times V_{DDP}$	-	-	V	²⁾ $4.5\text{ V} \leq V_{DDP} \leq 5.5\text{ V}$; Series resistance = $0\ \Omega$	P_5.3.3
Input hysteresis	HYS_{P2_ext} end	-	$0.09 \times V_{DDP}$	-	V	²⁾ $2.6\text{ V} \leq V_{DDP} < 4.5\text{ V}$; Series resistance = $0\ \Omega$	P_5.3.10
Input leakage current	I_{OZ1_P2}	-400	-	+400	nA	$4.5\text{ V} \leq V_{DDP} \leq 5.5\text{ V}$ V $T_j \leq 85^\circ\text{C}$, $0\text{ V} < V_{IN} < V_{DDP}$	P_5.3.4

(table continues...)

29 Electrical characteristics

Table 33 (continued) DC characteristics port 2

$V_S = 5.5\text{ V to }28\text{ V}$, $T_j = -40^\circ\text{C to }+150^\circ\text{C}$, all voltages with respect to ground, positive current flowing into pin (unless otherwise specified)

Parameter	Symbol	Values			Unit	Note or test condition	Number
		Min.	Typ.	Max.			
Input leakage current (extended temperature range)	$I_{OZ1_P2_T_}$ extend	-1	-	+1	µA	$2.6\text{ V} \leq V_{DDP} < 4.5\text{ V}$ $T_j \leq 150^\circ\text{C}$, $0\text{ V} < V_{IN} < V_{DDP}$	P_5.3.11
Pull level keep current ⁴⁾	I_{PLK_P2}	-	-	±30	µA	³⁾ $V_{PIN} \geq V_{IH}$ (up) $V_{PIN} \leq V_{IL}$ (dn)	P_5.3.5
Pull level force current ⁴⁾	I_{PLF_P2}	±750	-	-	µA	³⁾ $V_{PIN} \leq V_{IL}$ (up) $V_{PIN} \geq V_{IH}$ (dn)	P_5.3.6
Pin capacitance (digital inputs/outputs)	C_{IO_P2}	-	-	10	pF	²⁾	P_5.3.7

1) Tested at $V_{DDP} = 5\text{ V}$, specified for $4.9\text{ V} < V_{DDP} < 5.1\text{ V}$.

2) Not subject to production test, specified by design.

3) Keep current: Limit the current through this pin to the indicated value so that the enabled pull device can keep the default pin level: $V_{PIN} \geq V_{IH}$ for a pull-up; $V_{PIN} \leq V_{IL}$ for a pull-down. Force current: Drive the indicated minimum current through this pin to change the default pin level driven by the enabled pull device: $V_{PIN} \leq V_{IL}$ for a pull-up; $V_{PIN} \geq V_{IH}$ for a pull-down.

4) Negative current is representing pullup; positive current is representing pulldown.

29.5.4 Operating conditions

The following operating conditions must not be exceeded to ensure correct operation of the TLE9844QXC. All parameters specified in the following sections refer to these operating conditions, unless otherwise noticed.

Note: *Typical parameter values refer to room temperature and nominal supply voltage, minimum/maximum parameter values also include conditions of minimum/maximum temperature and minimum/maximum supply voltage. Additional details are described where applicable.*

Table 34 Operating condition parameters

$V_S = 5.5\text{ V to }28\text{ V}$, $T_j = -40^\circ\text{C to }+150^\circ\text{C}$, all voltages with respect to ground, positive current flowing into pin (unless otherwise specified)

Parameter	Symbol	Values			Unit	Note or test condition	Number
		Min.	Typ.	Max.			
Digital core supply voltage	V_{DDC}	1.35	-	1.6	V	Full active mode	P_5.4.1
Digital supply voltage for IO pads	V_{DDP}	2.55	5.0	5.5	V	¹⁾	P_5.4.2
Digital ground voltage	V_{SS}	0	-	0	V	Reference voltage	P_5.4.3
Overload current	I_{OV}	- 5.0	-	5.0	mA	Per IO pin ^{2) 3)}	P_5.4.4
Overload current	I_{OV}	- 2.0	-	5.0	mA	Per analog input pin ^{2) 3)}	P_5.4.5

(table continues...)

29 Electrical characteristics

Table 34 (continued) Operating condition parameters

$V_S = 5.5\text{ V to }28\text{ V}$, $T_j = -40^\circ\text{C to }+150^\circ\text{C}$, all voltages with respect to ground, positive current flowing into pin (unless otherwise specified)

Parameter	Symbol	Values			Unit	Note or test condition	Number
		Min.	Typ.	Max.			
Overload positive current coupling factor for analog inputs ⁴⁾	K_{OVA}	–	1.0×10^{-6}	1.0×10^{-4}	–	$I_{OV} > 0$ ³⁾	P_5.4.6
Overload negative current coupling factor for analog inputs	K_{OVA}	–	2.5×10^{-4}	1.5×10^{-3}	–	$I_{OV} < 0$ ³⁾	P_5.4.7
Overload positive current coupling factor for digital I/O pins	K_{OVD}	–	1.0×10^{-4}	5.0×10^{-3}	–	$I_{OV} > 0$ ³⁾	P_5.4.8
Overload negative current coupling factor for digital I/O pins	K_{OVD}	–	1.0×10^{-2}	3.0×10^{-2}	–	$I_{OV} < 0$ ³⁾	P_5.4.9
Absolute sum of overload currents	$\Sigma I_{OV} $	–	–	80	mA	³⁾	P_5.4.10

- 1) Performance of pad drivers, A/D converter, and flash module depends on V_{DDP} . If the external supply voltage V_{DDP} becomes lower than the specified operating range, a power reset must be generated. Otherwise, the core supply voltage V_{DD1} may rise above its specified operating range due to parasitic effects. This power reset can be generated by the on-chip SWD. If the SWD is disabled the power reset must be generated by activating the PORST input.
- 2) Overload conditions occur if the standard operating conditions are exceeded, that is the voltage on any pin exceeds the specified range: $V_{OV} > V_{IHmax}$ ($I_{OV} > 0$) or $V_{OV} < V_{ILmin}$ ($I_{OV} < 0$). The absolute sum of input overload currents on all pins may not exceed 50 mA. The supply voltages must remain within the specified limits. Proper operation under overload conditions depends on the application. Overload conditions must not occur on pin XTAL1 (powered by V_{DDIM}).
- 3) Not subject to production test, specified by design.
- 4) An overload current (I_{OV}) through a pin injects an error current (I_{INJ}) into the adjacent pins. This error current adds to that pin's leakage current (I_{OZ}). The value of the error current depends on the overload current and is defined by the overload coupling factor K_{OV} . The polarity of the injected error current is reversed from the polarity of the overload current that produces it. The total current through a pin is $|I_{TOT}| = |I_{OZ}| + (|I_{OV}| \times K_{OV})$. The additional error current may distort the input voltage on analog inputs.

29 Electrical characteristics

29.6 LIN/CXPI transceiver (TRX)

29.6.1 Transceiver general characteristics

Table 35 Recommended operating conditions

$V_S = 5.5\text{ V to }18\text{ V}$, $T_J = -40^\circ\text{C to }+150^\circ\text{C}$, all voltages with respect to ground, positive current flowing into the pin (unless otherwise specified)

Parameter	Symbol	Values			Unit	Note or condition	P-Number
		Min.	Typ.	Max.			
CXPI nominal bit duration	t_{bit}	50		208.4	μs	1) 2)	P_6.3.2

- 1) Transceiver configured for CXPI protocol. Nominal bit rate ranging from 4.8 kbps to 20 kbps.
 2) Not subject to production test, specified by design.

Table 36 Bus interface DC characteristics

$V_S = 5.5\text{ V to }18\text{ V}$, $T_J = -40^\circ\text{C to }+150^\circ\text{C}$, all voltages with respect to ground, positive current flowing into the pin (unless otherwise specified)

Parameter	Symbol	Values			Unit	Note or condition	P-Number
		Min.	Typ.	Max.			
Input leakage current	$I_{BUS_PAS_d}$ om	-1			mA	$V_S = 18\text{ V}$ $V_{BUS} = 0\text{ V}$ Network is in dominant state. Transmitter output is recessive state	P_6.1.13
Input leakage current	$I_{BUS_PAS_r}$ ec			20	μA	$V_S = 8\text{ V}$ $V_{BUS} = 18\text{ V}$ Network is in recessive state. Transmitter output is recessive state	P_6.1.14
Leakage current (loss of ground)	$I_{BUS_NO_G}$ ND	-1	-0.45	0	mA	$V_{BUS} = -12\text{ V}$ $V_S = 0\text{ V}$	P_6.1.11
Leakage current (loss of supply)	$I_{BUS_NO_B}$ AT		10	20	μA	$V_{BUS} = 18\text{ V}$ $V_S = 0\text{ V}$	P_6.1.12
Network pull-up resistance (responder node)	$R_{BUS,resp}$ $nder$	20	30	47	k Ω	1)	P_6.1.15
Transceiver input pin capacity	C_{LIN_IN}		15	30	pF	2)	P_6.1.36

- 1) Pull-up resistor present (also) in Sleep mode.
 2) Not subject to production test, specified by design.

29 Electrical characteristics

Table 37 Thermal shutdown

$V_S = 5.5\text{ V to }18\text{ V}$, $T_J = -40^\circ\text{C to }+150^\circ\text{C}$, all voltages with respect to ground, positive current flowing into the pin (unless otherwise specified)

Parameter	Symbol	Values			Unit	Note or condition	P-Number
		Min.	Typ.	Max.			
Thermal shutdown temperature	T_{JSD}	160	180	200	°C	1)	P_6.1.38
Thermal shutdown hysteresis	ΔT		10		°C	1)	P_6.1.39

1) Not subject to production test, specified by design.

29.6.1.1 Transmitter interface

Table 38 DC electrical characteristics

$V_S = 5.5\text{ V to }18\text{ V}$, $T_J = -40^\circ\text{C to }+150^\circ\text{C}$, all voltages with respect to ground, positive current flowing into the pin (unless otherwise specified)

Parameter	Symbol	Values			Unit	Note or condition	P-Number
		Min.	Typ.	Max.			
Network recessive output voltage (transmitter)	$V_{BUS,ro}$	$0.8 \cdot V_S$		V_S	V	TXD input high; LIN pin unconnected	P_6.1.9
Network short circuit current	$I_{BUS,sc}$	40	100	150	mA	$V_{BUS} = 18\text{ V}$ Current limit for transmitter dominant state	P_6.1.10

Table 39 Timings characteristics

Parameter	Symbol	Values			Unit	Note or condition	P-Number
		Min.	Typ.	Max.			
TxD dominant timeout	$t_{timeout}$	6	12	20	ms	Transmitter dominant state	P_6.1.37

29.6.1.2 Receiver interface

Table 40 DC electrical characteristics

$V_S = 5.5\text{ V to }18\text{ V}$, $T_J = -40^\circ\text{C to }+150^\circ\text{C}$, all voltages with respect to ground, positive current flowing into the pin (unless otherwise specified). Transceiver configured for Normal Slope mode operation.

Parameter	Symbol	Values			Unit	Note or condition	P-Number
		Min.	Typ.	Max.			
Receiver node dominant threshold voltage	$V_{th_dom_C}$ XPI	$0.423 \cdot V_S$		$0.486 \cdot V_S$	V		P_6.1.1.A

(table continues...)

29 Electrical characteristics

Table 40 (continued) DC electrical characteristics

$V_S = 5.5\text{ V to }18\text{ V}$, $T_J = -40^\circ\text{C to }+150^\circ\text{C}$, all voltages with respect to ground, positive current flowing into the pin (unless otherwise specified). Transceiver configured for Normal Slope mode operation.

Parameter	Symbol	Values			Unit	Note or condition	P-Number
		Min.	Typ.	Max.			
Receiver node dominant threshold voltage	$V_{th_dom_LIN}$	$0.4 \cdot V_S$			V		P_6.1.1
Receiver dominant state	V_{BUSdom_CXPI}	-27		$0.423 \cdot V_S$	V	Refer to Figure 47	P_6.1.2.A
Receiver dominant state	V_{BUSdom_LIN}	-27		$0.4 \cdot V_S$	V		P_6.1.2
Receiver node recessive threshold voltage	$V_{th_rec_CXPI}$	$0.493 \cdot V_S$		$0.556 \cdot V_S$	V		P_6.1.3.A
Receiver node recessive threshold voltage	$V_{th_rec_LIN}$			$0.6 \cdot V_S$	V		P_6.1.3
Receiver recessive state	V_{BUSrec_CXPI}	$0.556 \cdot V_S$		$1.15 \cdot V_S$ ¹⁾	V	Refer to Figure 47	P_6.1.4.A
Receiver recessive state	V_{BUSrec_LIN}	$0.6 \cdot V_S$		$1.15 \cdot V_S$	V		P_6.1.4
Receiver center voltage	V_{BUS_CNT}	$0.475 \cdot V_S$		$0.525 \cdot V_S$	V	²⁾	P_6.1.5
Receiver hysteresis	V_{HYS_CXPI}			$0.133 \cdot V_S$	V	³⁾ Refer to Figure 47	P_6.1.6.A
Receiver hysteresis	V_{HYS_LIN}	$0.07 \cdot V_S$		$0.175 \cdot V_S$	V	⁴⁾	P_6.1.6

1) Maximum limit specified by design.

2) $V_{BUS_CNT} = 0.5 \times (V_{BUSdom} + V_{BUSrec})$

3) $V_{HYS} = V_{BUSrec} - V_{BUSdom}$

4) $V_{HYS} = V_{BUSrec} - V_{BUSdom}$

Table 41 Wake-up static characteristics

Parameter	Symbol	Values			Unit	Note or condition	P-Number
		Min.	Typ.	Max.			
Wake-up threshold voltage	$V_{BUS,wk}$	$0.4 \cdot V_S$	$0.5 \cdot V_S$	$0.6 \cdot V_S$	V		P_6.1.7

29.6.2 LIN transceiver

29 Electrical characteristics

29.6.2.1 Receiver interface

Table 42 Timing requirements

$V_S = 5.5\text{ V to }18\text{ V}$, $T_J = -40^\circ\text{C to }+150^\circ\text{C}$, all voltages with respect to ground, positive current flowing into the pin (unless otherwise specified)

Parameter	Symbol	Values			Unit	Note or condition	P-Number
		Min.	Typ.	Max.			
Transceiver Normal Slope mode							
Propagation delay network dominant to RxD LOW	$t_{d(L),R}$	0.1	1	6	μs	LIN Spec ISO17987-4 (Param. 31)	P_6.1.16
Propagation delay network recessive to RxD HIGH	$t_{d(H),R}$	0.1	1	6	μs	LIN Spec ISO17987-4 (Param. 31)	P_6.1.17
Receiver delay symmetry	$t_{sym,R}$	-2		2	μs	LIN Spec ISO17987-4 (Param. 32) ¹⁾	P_6.1.18
Transceiver Low Slope mode							
Propagation delay network dominant to RxD LOW	$t_{d(L),R}$	0.1	1	6	μs	LIN Spec ISO17987-4 (Param. 31)	P_6.1.21
Propagation delay network recessive to RxD HIGH	$t_{d(H),R}$	0.1	1	6	μs	LIN Spec ISO17987-4 (Param. 31)	P_6.1.22
Receiver delay symmetry	$t_{sym,R}$	-2		2	μs	LIN Spec ISO17987-4 (Param. 32) ¹⁾	P_6.1.23
Transceiver Fast Slope mode							
Propagation delay network dominant to RxD LOW	$t_{d(L),R}$	0.1	1	6	μs	LIN Spec ISO17987-4 (Param. 31)	P_6.1.26
Propagation delay network recessive to RxD HIGH	$t_{d(H),R}$	0.1	1	6	μs	LIN Spec ISO17987-4 (Param. 31)	P_6.1.27
Receiver delay symmetry	$t_{sym,R}$	-2		2	μs	LIN Spec ISO17987-4 (Param. 32) ¹⁾	P_6.1.42
Transceiver Flash mode							
Propagation delay network dominant to RxD LOW	$t_{d(L),R}$	0.1	0.5	6	μs	LIN Spec ISO17987-4 (Param. 31)	P_6.1.31
Propagation delay network recessive to RxD HIGH	$t_{d(H),R}$	0.1	0.5	6	μs	LIN Spec ISO17987-4 (Param. 31)	P_6.1.32

(table continues...)

29 Electrical characteristics

Table 42 (continued) Timing requirements

$V_S = 5.5\text{ V to }18\text{ V}$, $T_J = -40^\circ\text{C to }+150^\circ\text{C}$, all voltages with respect to ground, positive current flowing into the pin (unless otherwise specified)

Parameter	Symbol	Values			Unit	Note or condition	P-Number
		Min.	Typ.	Max.			
Receiver delay symmetry	$t_{sym,R}$	-1		2	μs	LIN Spec ISO17987-4 (Param. 32) ¹⁾	P_6.1.44

1) $t_{sym,R} = t_{d(L),R} - t_{d(H),R}$

Table 43 Wake-up timing characteristics

Parameter	Symbol	Values			Unit	Note or condition	P-Number
		Min.	Typ.	Max.			
Wake-up dominant pulse width	$t_{WK,bus}$	30		150	μs		P_6.1.8

29.6.2.2 Transmitter interface

Table 44 Timings characteristics

$V_S = 5.5\text{ V to }18\text{ V}$, $T_J = -40^\circ\text{C to }+150^\circ\text{C}$, all voltages with respect to ground, positive current flowing into the pin (unless otherwise specified)

Parameter	Symbol	Values			Unit	Note or condition	P-Number
		Min.	Typ.	Max.			

Transceiver Normal Slope mode

Duty-cycle D1: Normal Slope mode (for worst case at 20 kBit/s)	t_{duty1}	0.396			-	$7\text{ V} \leq V_S \leq 18\text{ V}$; $t_{bit} = 52\ \mu\text{s}$; $TH_{Rec(max)} = 0.744 \times V_S$; $TH_{Dom(max)} = 0.581 \times V_S$; ^{1);.2)}	P_6.2.52
Duty-cycle D1: Normal Slope mode (for worst case at 20 kBit/s)	t_{duty1}	0.396			-	$5.5\text{ V} \leq V_S \leq 7\text{ V}$; $t_{bit} = 52\ \mu\text{s}$; $TH_{Rec(max)} = 0.665 \times V_S$; $TH_{Dom(max)} = 0.499 \times V_S$; ^{1);.2)}	P_6.2.53
Duty-cycle D2: Normal Slope mode (for worst case at 20 kBit/s)	t_{duty2}			0.581	-	$7.6\text{ V} \leq V_S \leq 18\text{ V}$; $t_{bit} = 52\ \mu\text{s}$; $TH_{Rec(min)} = 0.422 \times V_S$; $TH_{Dom(min)} = 0.284 \times V_S$; ^{3);.2)}	P_6.2.54
Duty-cycle D2: Normal Slope mode (for worst case at 20 kBit/s)	t_{duty2}			0.581	-	$6.1\text{ V} \leq V_S \leq 7.6\text{ V}$; $t_{bit} = 52\ \mu\text{s}$; $TH_{Rec(min)} = 0.496 \times V_S$; $TH_{Dom(min)} = 0.361 \times V_S$; ^{3);.2)}	P_6.2.55

(table continues...)

29 Electrical characteristics

Table 44 (continued) Timings characteristics

$V_S = 5.5\text{ V to }18\text{ V}$, $T_J = -40^\circ\text{C to }+150^\circ\text{C}$, all voltages with respect to ground, positive current flowing into the pin (unless otherwise specified)

Parameter	Symbol	Values			Unit	Note or condition	P-Number
		Min.	Typ.	Max.			
Duty-cycle D3: Normal Slope mode (for worst case at 10.4 kBit/s)	t_{duty3}	0.417			-	$7\text{ V} \leq V_S \leq 18\text{ V}$; $t_{bit} = 96\ \mu\text{s}$; $TH_{Rec(max)} = 0.778 \times V_S$; $TH_{Dom(max)} = 0.616 \times V_S$; 1); 2)	P_6.2.56
Duty-cycle D3: Normal Slope mode (for worst case at 10.4 kBit/s)	t_{duty3}	0.417			-	$5.5\text{ V} \leq V_S \leq 7\text{ V}$; $t_{bit} = 96\ \mu\text{s}$; $TH_{Rec(max)} = 0.665 \times V_S$; $TH_{Dom(max)} = 0.499 \times V_S$; 1); 2)	P_6.2.57
Duty-cycle D4: Normal Slope mode (for worst case at 10.4 kBit/s)	t_{duty4}			0.590	-	$7.6\text{ V} \leq V_S \leq 18\text{ V}$; $t_{bit} = 96\ \mu\text{s}$; $TH_{Rec(min)} = 0.389 \times V_S$; $TH_{Dom(min)} = 0.251 \times V_S$; 3); 2)	P_6.2.58
Duty-cycle D4: Normal Slope mode (for worst case at 10.4 kBit/s)	t_{duty4}			0.590	-	$6.1\text{ V} \leq V_S \leq 7.6\text{ V}$; $t_{bit} = 96\ \mu\text{s}$; $TH_{Rec(min)} = 0.496 \times V_S$; $TH_{Dom(min)} = 0.361 \times V_S$; 3); 2)	P_6.2.59

Transceiver Fast Slope mode

Duty-cycle D5: Fast Slope mode (for worst case at 62.5 kBit/s)	t_{duty5}	0.395			-	$5.5\text{ V} \leq V_S \leq 18\text{ V}$. $t_{bit} = 16\ \mu\text{s}$. $TH_{Rec(max)} = 0.744 \times V_S$. $TH_{Dom(max)} = 0.581 \times V_S$; 1); 4)	P_6.1.29
Duty-cycle D6: Fast Slope mode (for worst case at 62.5 kBit/s)	t_{duty6}			0.581	-	$5.5\text{ V} \leq V_S \leq 18\text{ V}$; $t_{bit} = 16\ \mu\text{s}$; $TH_{Rec(min)} = 0.422 \times V_S$; $TH_{Dom(min)} = 0.284 \times V_S$; 3); 4)	P_6.1.30

Transceiver Flash mode

Duty-cycle D7: Flash mode (for worst case at 115 kBit/s)	t_{duty7}	0.42		0.55	-	$V_S = 13.5\text{ V}$; $T_J = 25^\circ\text{C}$; $t_{bit} = 8.7\ \mu\text{s}$; $TH_{Rec(max)} = 0.6 \times V_S$; $TH_{Dom(max)} = 0.4 \times V_S$; 1); 5)	P_6.2.60
--	-------------	------	--	------	---	--	----------

1) $Duty\text{-cycle} = t_{bus_rec(min)} / (2 \times t_{bit})$

2) Transceiver configured for LIN operation in Normal Slope mode. LIN network load conditions:

- $C_{BUS} = 1\text{ nF}$, $R_{BUS(PULL-UP)} = 1\text{ k}\Omega$
- $C_{BUS} = 6.8\text{ nF}$, $R_{BUS(PULL-UP)} = 660\ \Omega$
- $C_{BUS} = 10\text{ nF}$, $R_{BUS(PULL-UP)} = 500\ \Omega$

LIN Spec ISO17987-4

3) $Duty\text{-cycle} = t_{bus_rec(max)} / (2 \times t_{bit})$

29 Electrical characteristics

- 4) Transceiver configured for LIN operation in Fast Slope mode. LIN network load conditions:
 - $C_{BUS} = 220 \text{ pF}$, $R_{BUS(PULL-UP)} = 500 \Omega$
- 5) Transceiver configured for LIN operation in Flash mode. LIN network load conditions:
 - $C_{BUS} = 220 \text{ pF}$, $R_{BUS(PULL-UP)} = 500 \Omega$

29.6.2.3 LIN waveform diagrams

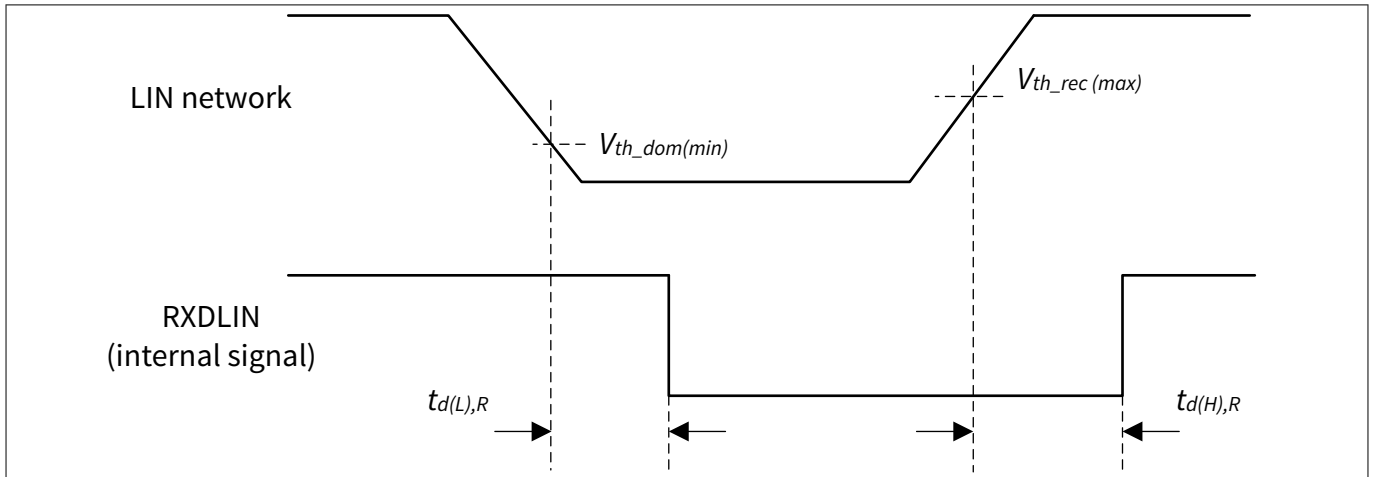

Figure 41 Receiver propagation delay

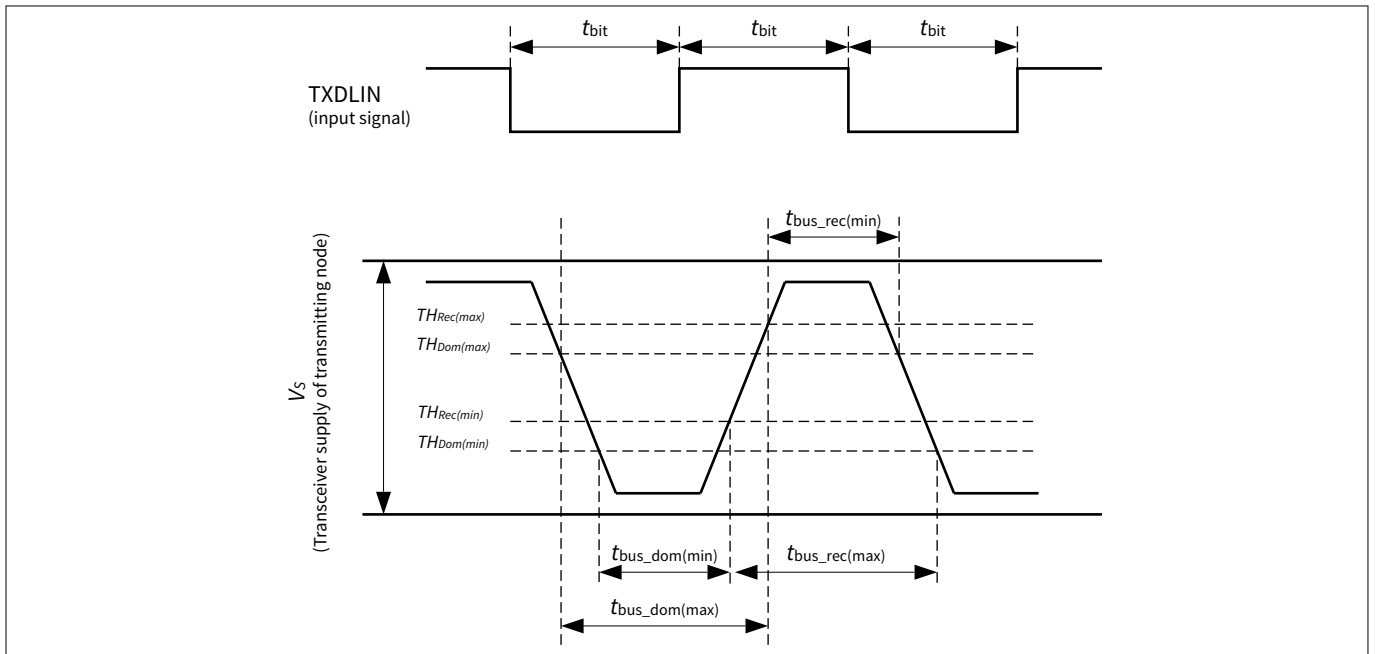

Figure 42 LIN network timing parameters

29.6.3 CXPI transceiver

29 Electrical characteristics

29.6.3.1 Receiver interface

Table 45 Wake-up timing characteristics

$V_S = 5.5\text{ V to }18\text{ V}$, $T_J = -40^\circ\text{C to }+150^\circ\text{C}$, all voltages with respect to ground, positive current flowing into the pin (unless otherwise specified).

Parameter	Symbol	Values			Unit	Note or condition	P-Number
		Min.	Typ.	Max.			
Wake-up spike filter time (commander node)	$t_{rx_wakeup_clk}$	30 ¹⁾		150 ²⁾	μs	Transceiver operates in sleep (wake-capable) mode. Refer to "Wake-Up Pulse Detection by Commander Node" timing diagrams ³⁾	P_6.2.37
Wake-up spike filter time (responder node)	t_{rx_wakeup}	0.5 ¹⁾		5 ²⁾	μs	Transceiver operates in sleep (wake-capable) mode. Refer to "Network Wake-Up Pulse Waveforms" timing diagrams ³⁾	P_6.2.38

- 1) This parameter is defining the minimum dominant time of a valid wake-up pulse.
- 2) This parameter is defining the maximum dominant time of an invalid wake-up pulse.
- 3) Not subject to production test.

Table 46 Timing requirements

$V_S = 5.5\text{ V to }18\text{ V}$, $T_J = -40^\circ\text{C to }+150^\circ\text{C}$, all voltages with respect to ground, positive current flowing into the pin (unless otherwise specified).

Parameter	Symbol	Values			Unit	Note or condition	P-Number
		Min.	Typ.	Max.			
Receiver spike filter time	t_{rx_filter}	0.5 ¹⁾		2.1 ²⁾	μs	Transceiver operates in normal or receive-only mode ³⁾	P_6.2.33
Receiver propagation delay (CXPI rising edge)	$t_{rx_pwm_p_dr}$			2.1	μs	$V_{stim_dom} = 1.2\text{ V}$. $V_{stim_rec} = V_S - 1\text{ V}$. $V_{th_rec} = 0.556 \times V_S$. CXPI network slew-rate $\leq 5\text{ V}/\mu\text{s}$. Transceiver operates in normal or receive-only mode. Refer to "Receiver Propagation Delay" timing diagrams	P_6.2.34

(table continues...)

29 Electrical characteristics

Table 46 (continued) Timing requirements

$V_S = 5.5\text{ V to }18\text{ V}$, $T_J = -40^\circ\text{C to }+150^\circ\text{C}$, all voltages with respect to ground, positive current flowing into the pin (unless otherwise specified).

Parameter	Symbol	Values			Unit	Note or condition	P-Number
		Min.	Typ.	Max.			
Receiver propagation delay (CXPI falling edge)	$t_{rx_pwm_p_df}$			2.1	μs	$V_{stim_dom} = 1.2\text{ V}$. $V_{stim_rec} = V_S - 1\text{ V}$. $V_{th_dom} = 0.423 \times V_S$. CXPI network slew-rate $\leq 5\text{ V}/\mu\text{s}$. Transceiver operates in normal or receive-only mode. Refer to "Receiver Propagation Delay" timing diagrams	P_6.2.35
Symmetry of receiver propagation delay (CXPI rising edge vs. falling edge)	$t_{rx_pwm_p_d_sym}$	-2		2	μs	Transceiver operates in normal or receive-only mode ⁴⁾	P_6.2.36

- 1) This parameter is defining the minimum pulse width of a propagated pulse.
- 2) This parameter is defining the maximum pulse width of a non-propagated pulse.
- 3) Not subject to production test.
- 4) $t_{rx_0_hi_cont} = (0,06 \times t_{bit}) - t_{rx_pwm_pd_sym}$

29.6.3.2 Transmitter interface

Table 47 Timing characteristics

$V_S = 5.5\text{ V to }18\text{ V}$, $T_J = -40^\circ\text{C to }+150^\circ\text{C}$, all voltages with respect to ground, positive current flowing into the pin (unless otherwise specified).

Parameter	Symbol	Values			Unit	Note or condition	P-Number
		Min.	Typ.	Max.			
Transmitter jitter (CXPI falling edge)	$\Delta t_{bit_drive_r}$	-0.005		0.005	-	Transmitter jitter on CXPI falling edge. The jitter tolerance is related to the bit width (t_{bit_ref}). Refer to "CXPI Network Falling Edge Transmitter Jitter" timing diagram ¹⁾	P_6.2.40

(table continues...)

29 Electrical characteristics

Table 47 (continued) Timing characteristics

$V_S = 5.5\text{ V to }18\text{ V}$, $T_J = -40^\circ\text{C to }+150^\circ\text{C}$, all voltages with respect to ground, positive current flowing into the pin (unless otherwise specified).

Parameter	Symbol	Values			Unit	Note or condition	P-Number
		Min.	Typ.	Max.			
Transmitter propagation delay of clock commander (CXPI falling edge)	$t_{tx_pwm_p_df_clk}$			16.9	μs	CXPI network load conditions: <ul style="list-style-type: none"> $C_{BUS} = 10\text{ nF}$; $R_{BUS(PULL-UP)} = 500\ \Omega$ Threshold conditions: <ul style="list-style-type: none"> $TH_{tx_dom} = 0.3 \times V_S$ Refer to "Transmitter Propagation Delay (Clock Commander)" timing diagram	P_6.2.41
CXPI network fall time (clock commander)	$t_{tx_pwm_sl_ope_clk}$			8	μs	$t_{bit} = 50\ \mu\text{s}$ CXPI network load conditions: <ul style="list-style-type: none"> $C_{BUS} = 10\text{ nF}$; $R_{BUS(PULL-UP)} = 500\ \Omega$ Threshold conditions: <ul style="list-style-type: none"> $TH_{tx_rec} = 0.7 \times V_S$ $TH_{tx_dom} = 0.3 \times V_S$ Refer to "Waveforms for Logic Value '0'" timing diagram	P_6.2.42
Transmitter propagation delay (CXPI rising edge)	$t_{tx_pwm_p_dr}$			16.9	μs	CXPI network load conditions: <ul style="list-style-type: none"> $C_{BUS} = 10\text{ nF}$; $R_{BUS(PULL-UP)} = 500\ \Omega$ Threshold conditions: <ul style="list-style-type: none"> $TH_{tx_dom} = 0.3 \times V_S$ $TH_{tx_rec} = 0.7 \times V_S$ Refer to "Transmitter Propagation Delay (Clock Commander)" and "Transmitter Propagation Delay (Responder Node)" timing diagrams	P_6.2.43

(table continues...)

29 Electrical characteristics

Table 47 (continued) Timing characteristics

$V_S = 5.5\text{ V to }18\text{ V}$, $T_J = -40^\circ\text{C to }+150^\circ\text{C}$, all voltages with respect to ground, positive current flowing into the pin (unless otherwise specified).

Parameter	Symbol	Values			Unit	Note or condition	P-Number
		Min.	Typ.	Max.			
Transmitter propagation delay (CXPI falling edge)	$t_{tx_pwm_pdf}$			2.9	μs	CXPI network load conditions: • $C_{BUS} = 10\text{ nF}$; $R_{BUS(PULL-UP)} = 500\ \Omega$ Threshold conditions: • $TH_{tx_dom} = 0.3 \times V_S$ Refer to "Transmitter Propagation Delay (Responder Node)" timing diagrams Requires special test mode implementation - refer to analog module DfT documentation	P_6.2.44
Loop delay timing from transmitter input to receiver output (clock commander, CXPI rising edge)	t_{loopr_pwm}			19	μs	CXPI network load conditions: • $C_{BUS} = 10\text{ nF}$; $R_{BUS(PULL-UP)} = 500\ \Omega$ Refer to "Loop Delay" timing diagrams	P_6.2.46
Loop delay timing from transmitter input to receiver output (clock commander, CXPI falling edge)	t_{loopf_pwm}			19	μs	CXPI network load conditions: • $C_{BUS} = 10\text{ nF}$; $R_{BUS(PULL-UP)} = 500\ \Omega$ Refer to "Loop Delay" timing diagrams	P_6.2.47
LO level duty-cycle for a logical value '1'	$D_{tx_1_lo_dom}$	11			%	$t_{bit} = 50\ \mu\text{s}$ $t_{txpwm_lo} = 13.75\ \mu\text{s}$ CXPI network load conditions: • $C_{BUS} = 1\text{ nF}$, $R_{BUS(PULL-UP)} = 1\text{ k}\Omega$ Threshold conditions: • $TH_{tx_dom} = 0.3 \times V_S$ Refer to "Waveforms for Logic Value '1'" timing diagram ²⁾	P_6.2.48

(table continues...)

29 Electrical characteristics

Table 47 (continued) Timing characteristics

$V_S = 5.5\text{ V to }18\text{ V}$, $T_J = -40^\circ\text{C to }+150^\circ\text{C}$, all voltages with respect to ground, positive current flowing into the pin (unless otherwise specified).

Parameter	Symbol	Values			Unit	Note or condition	P-Number
		Min.	Typ.	Max.			
LO level duty-cycle for a logical value '1'	$D_{tx_1_lo_rec}$			45	%	$t_{bit} = 50\ \mu\text{s}$ $t_{txpwm_lo} = 11.25\ \mu\text{s}$ CXPI network load conditions: • $C_{BUS} = 10\ \text{nF}$, $R_{BUS(PULL-UP)} = 500\ \Omega$ Threshold conditions: • $TH_{tx_rec} = 0.7 \times V_S$ Refer to "Waveforms for Logic Value '1'" timing diagram ³⁾	P_6.2.49
LO level duty-cycle for a logical value '0'	$D_{tx_0_lo_dom}$	17			%	$t_{bit} = 50\ \mu\text{s}$ $t_{txpwm_lo} = 16.75\ \mu\text{s}$ CXPI network load conditions: • $C_{BUS} = 1\ \text{nF}$, $R_{BUS(PULL-UP)} = 1\ \text{k}\Omega$ Threshold conditions: • $TH_{tx_dom} = 0.3 \times V_S$ Refer to "Waveforms for Logic Value '0'" timing diagram ^{4) 5)}	P_6.2.50

- 1) Not subject to production test, specified by design.
- 2) $D_{tx_1_lo_dom} = 100 \times t_{tx_1_lo_dom} / t_{bit}$
- 3) $D_{tx_1_lo_rec} = 100 \times t_{tx_1_lo_rec} / t_{bit}$
- 4) $D_{tx_0_lo_rec} = 100 \times t_{tx_0_lo_rec} / t_{bit}$
- 5) $D_{tx_0_lo_dom}$ refers to the $D_{tx_0_lo}$ parameter (CXPI ISO20794-4 specification)

29.6.3.3 CXPI waveform diagrams

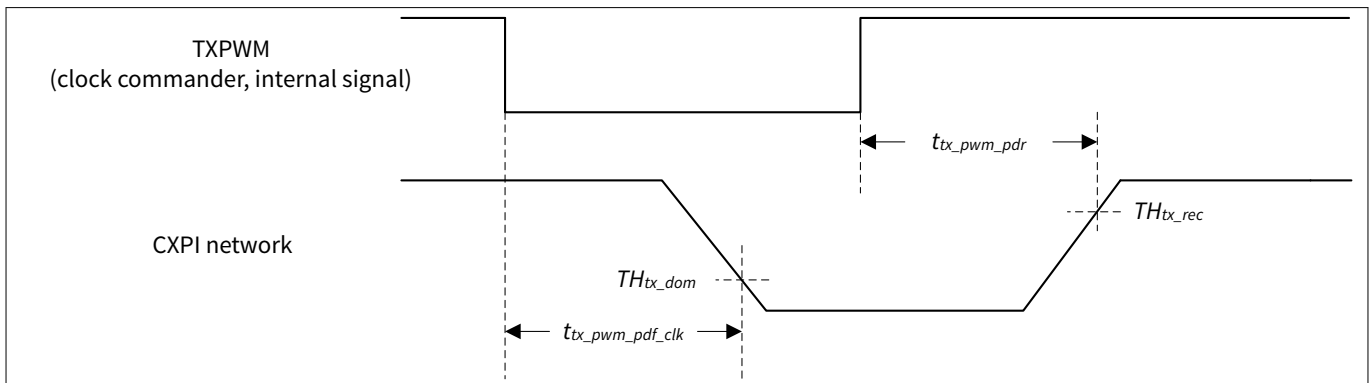

Figure 43 Transmitter propagation delay (clock commander)

29 Electrical characteristics

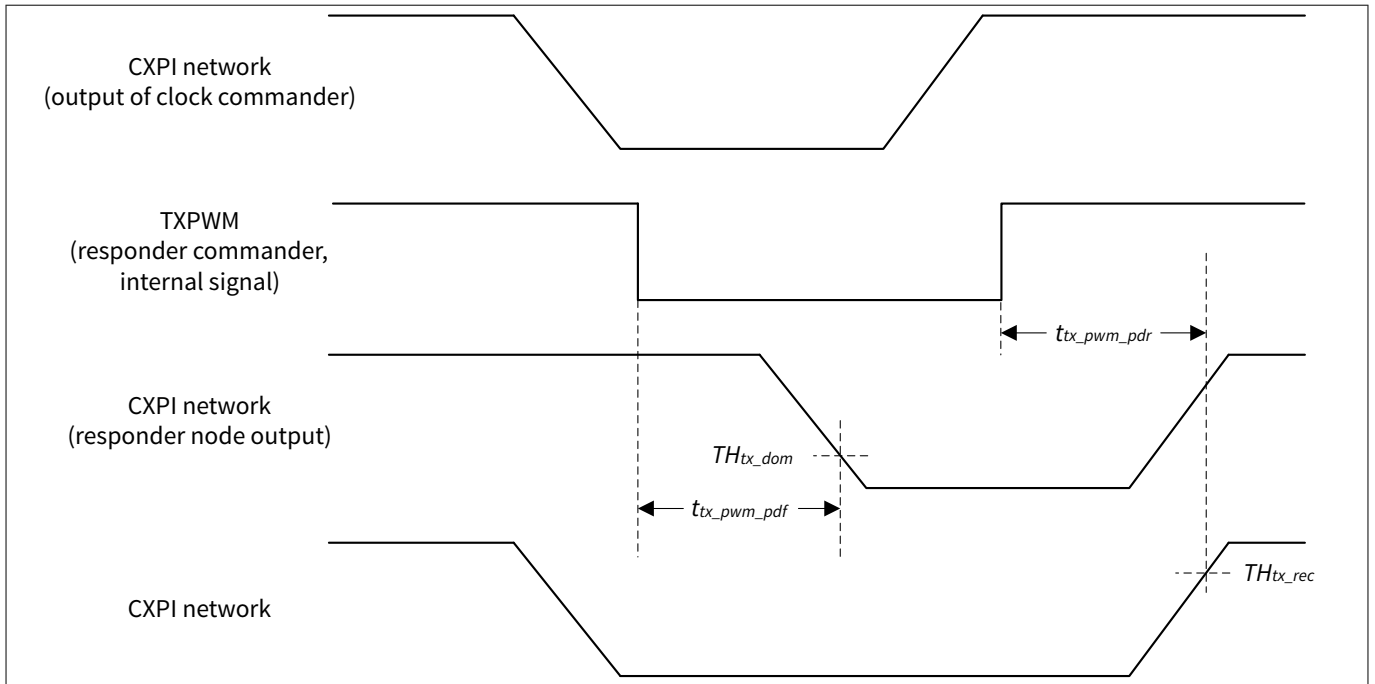

Figure 44 Transmitter propagation delay (responder node)

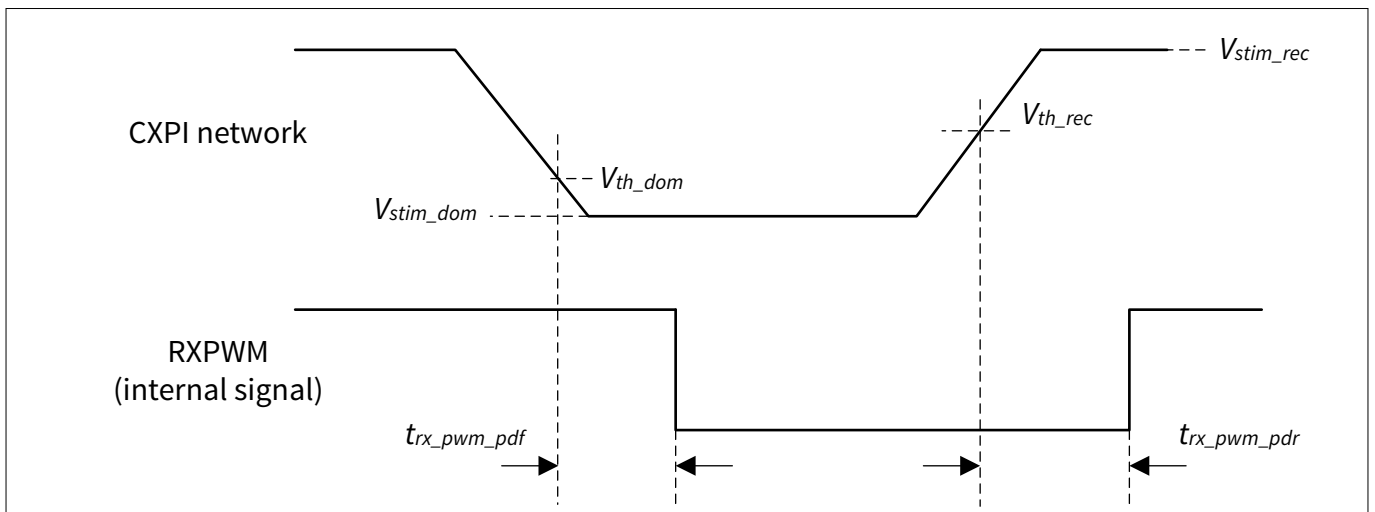

Figure 45 Receiver propagation delay

29 Electrical characteristics

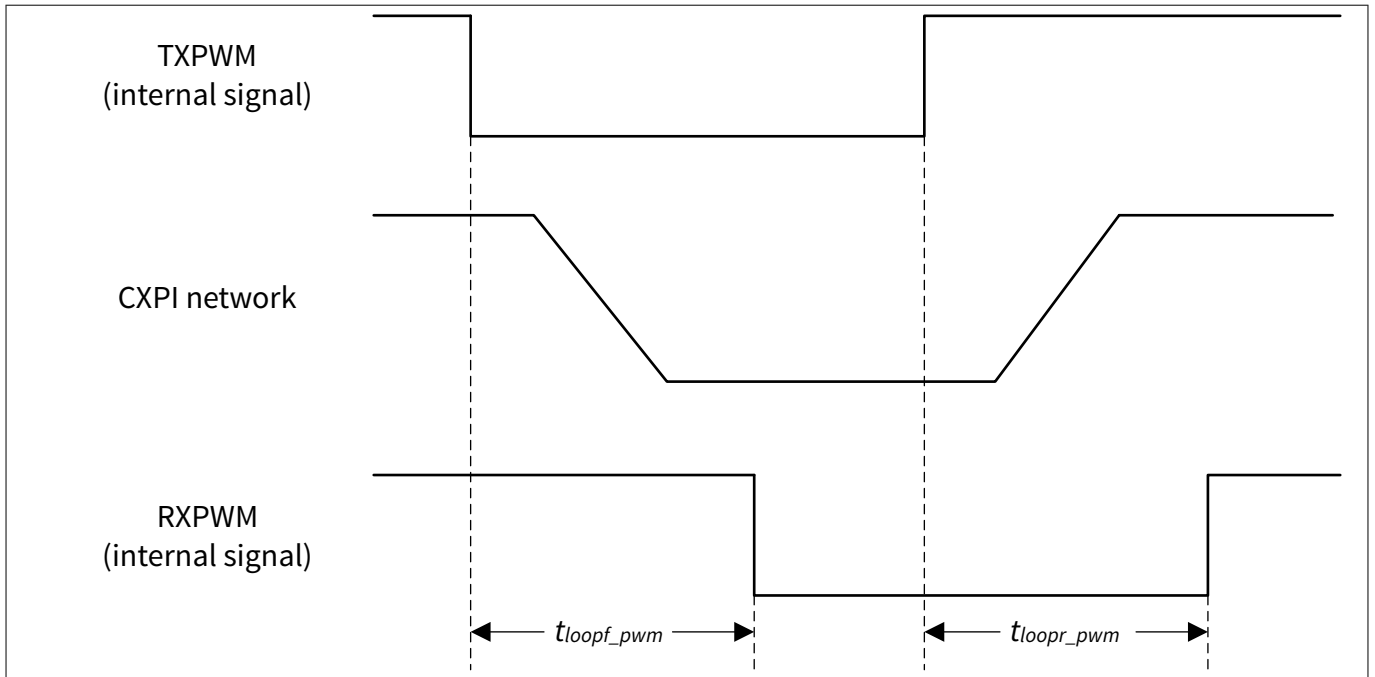

Figure 46 Loop delay

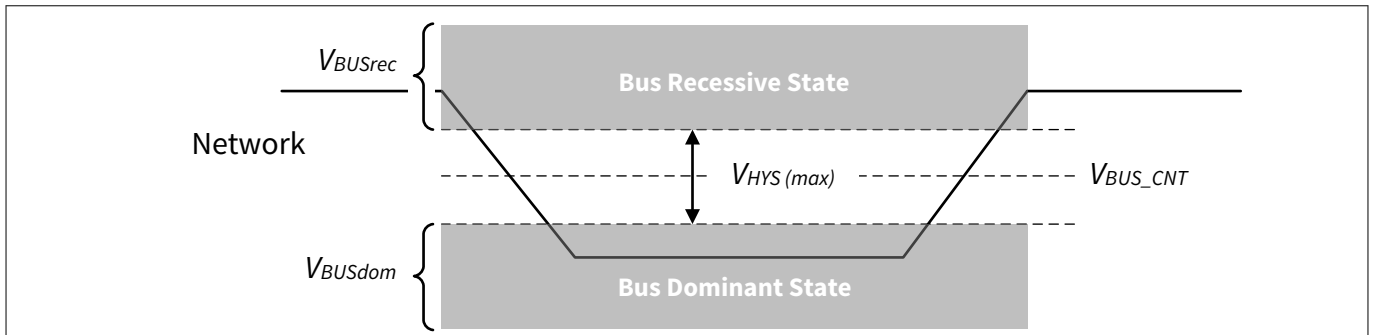

Figure 47 Definition of bus states

29 Electrical characteristics

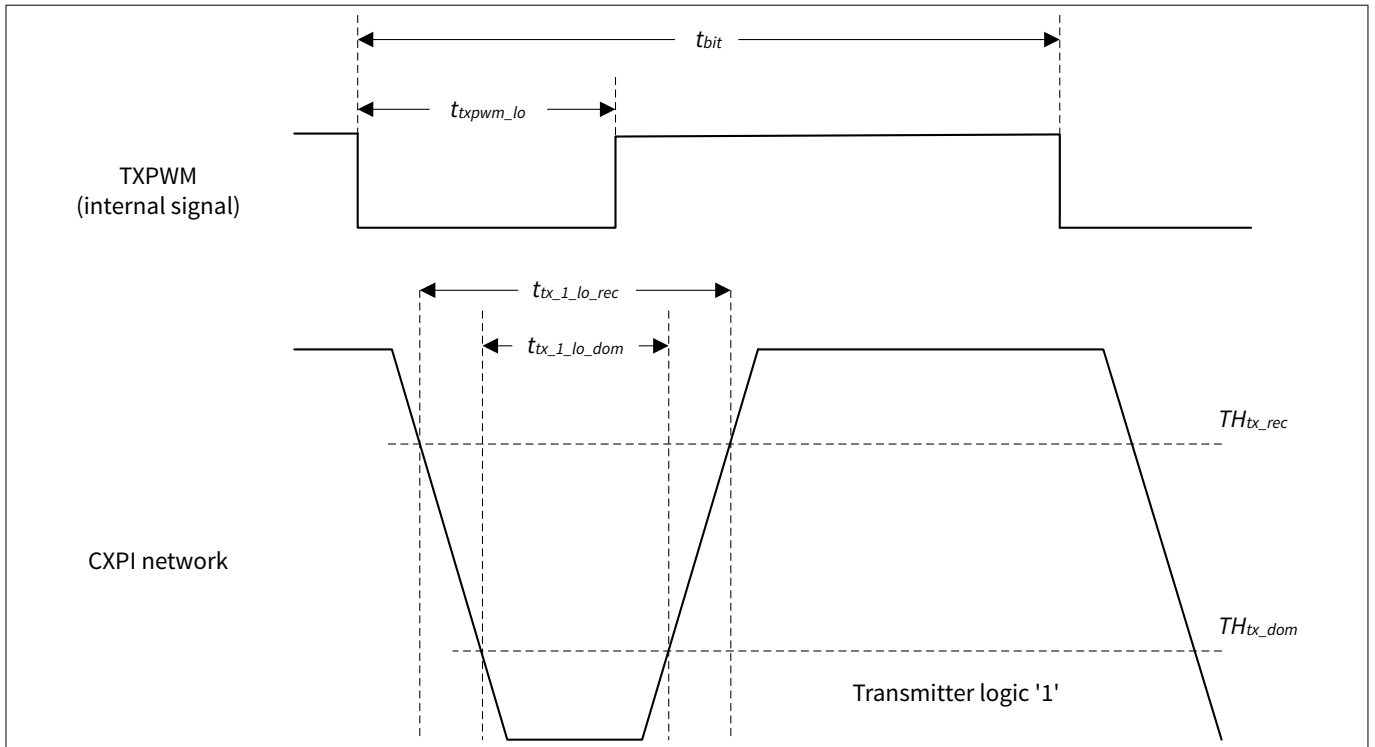

Figure 48 Waveforms for logic value '1'

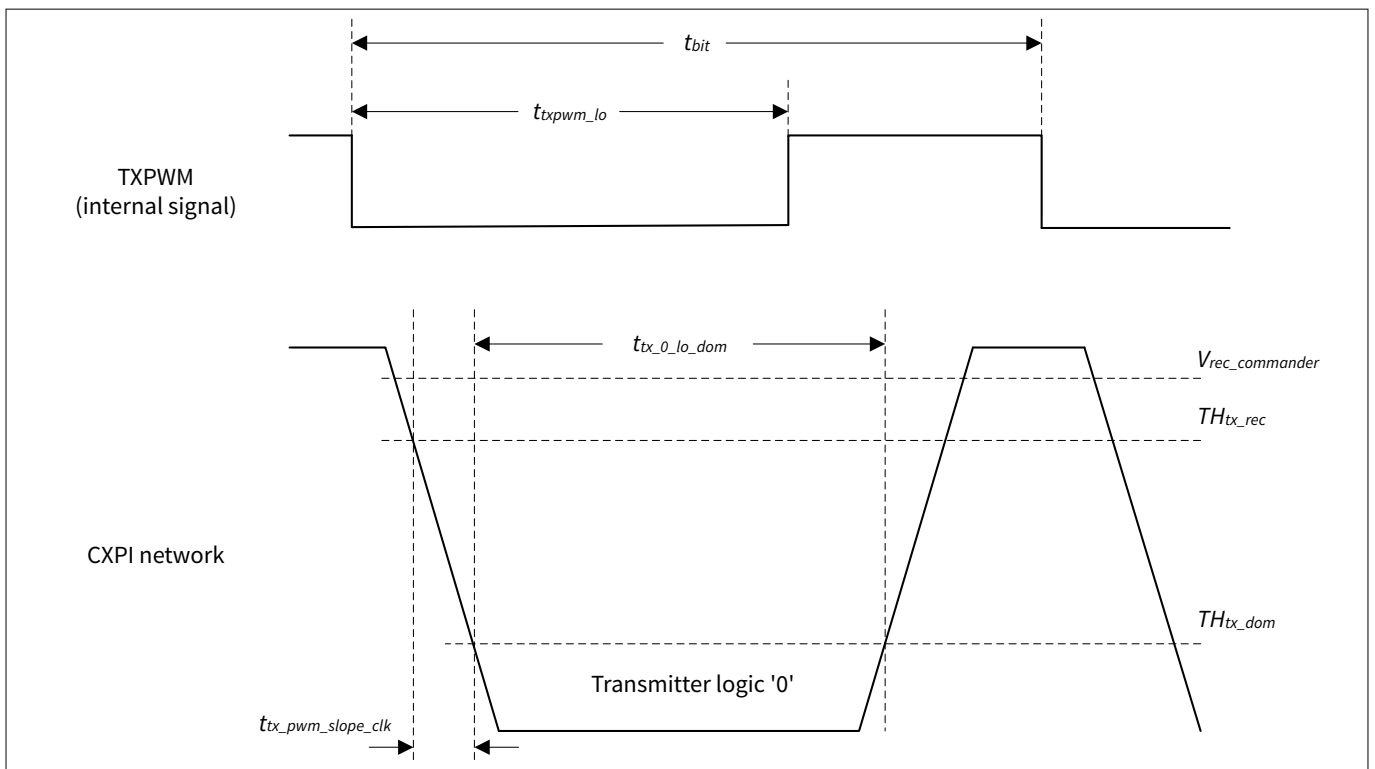

Figure 49 Waveforms for logic value '0'

29 Electrical characteristics

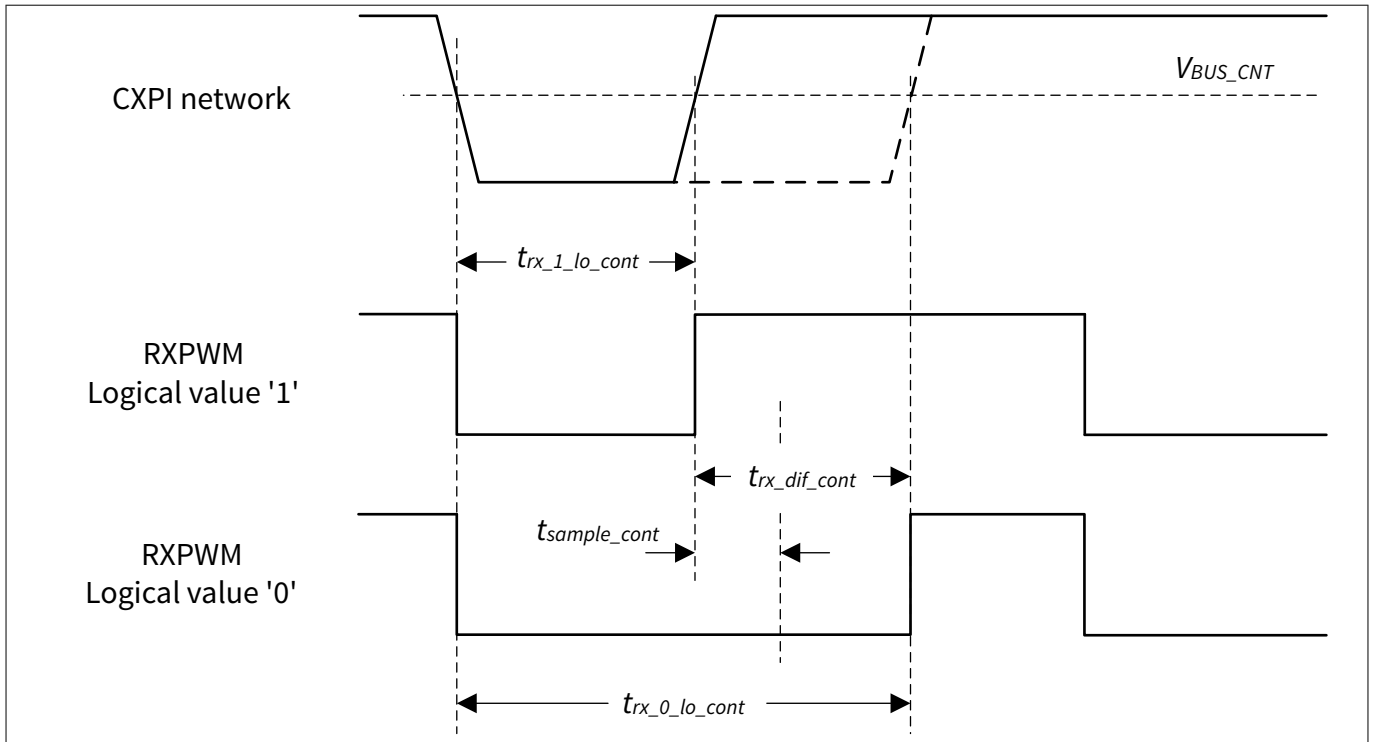

Figure 50 Width difference of LO levels

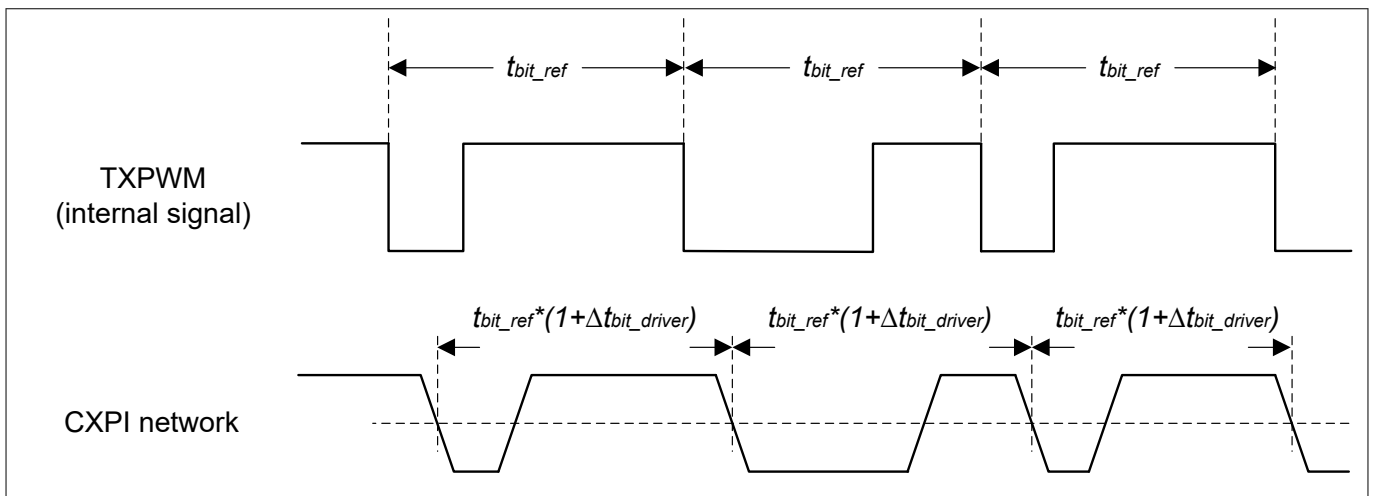

Figure 51 Network falling edge transmitter jitter

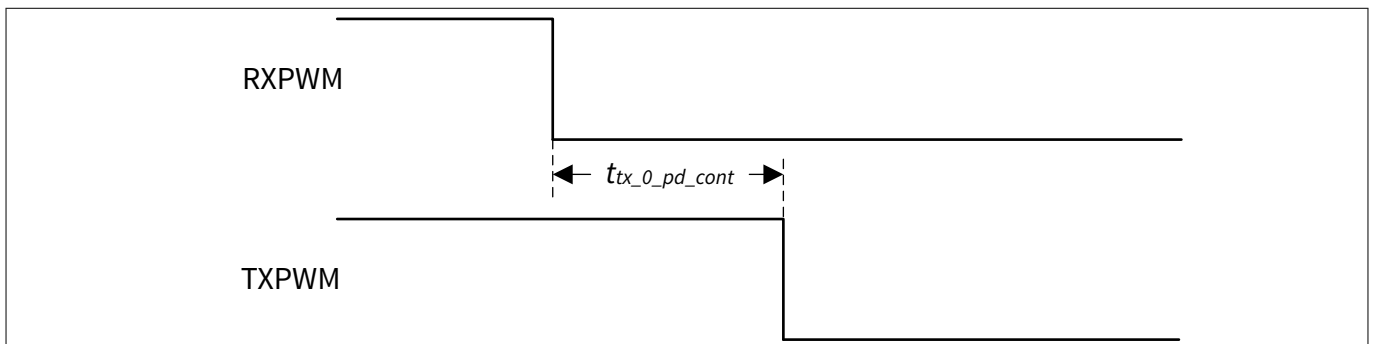

Figure 52 Transmitter propagation delay for logic value '0' (responder node)

29 Electrical characteristics

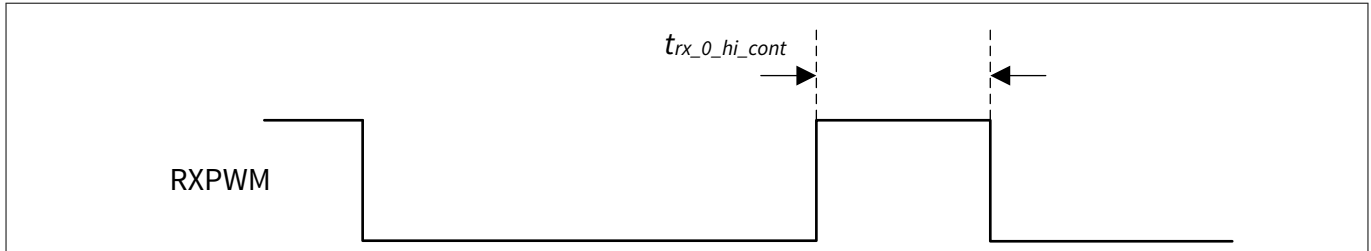

Figure 53 Receiver HI level detection

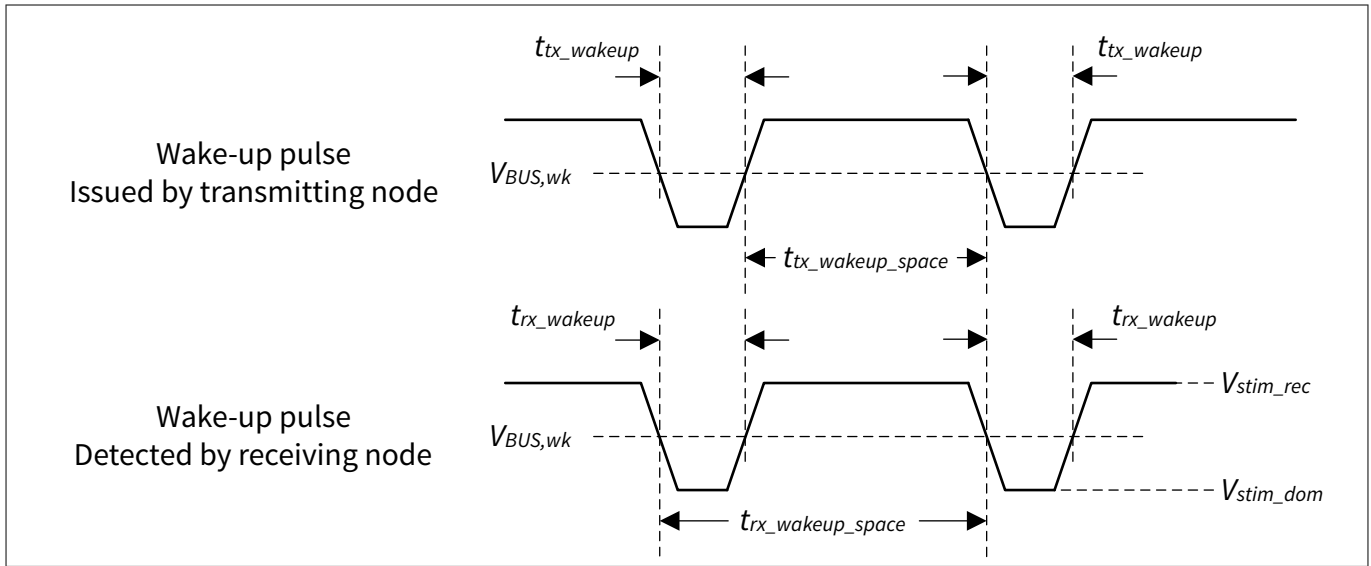

Figure 54 Network wake-up pulse waveforms

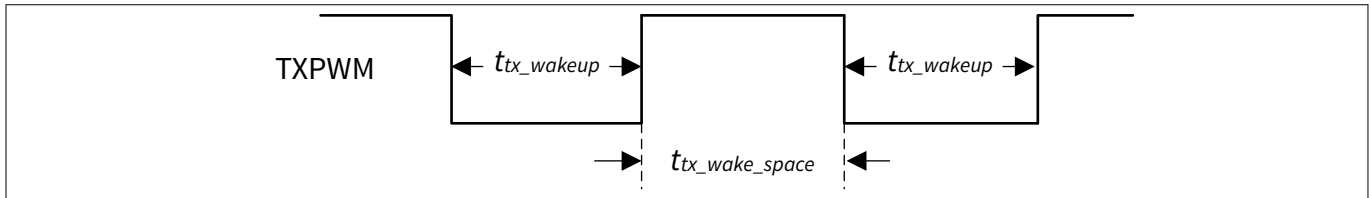

Figure 55 Wake-up pulse generated by responder node

29.6.4 Parameter test circuit

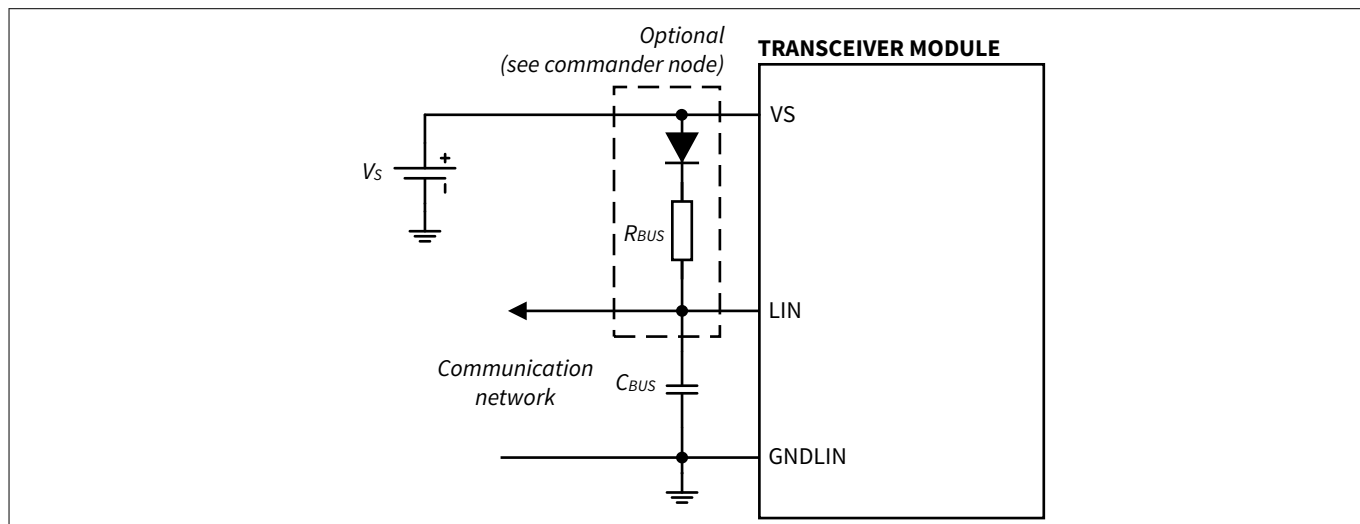

Figure 56 Parameter test circuit

29 Electrical characteristics

29.7 CXPI protocol controller (MXCXPI)

Table 48 Timing requirements

$V_S = 5.5\text{ V to }18\text{ V}$, $T_J = -40^\circ\text{C to }+150^\circ\text{C}$, all voltages with respect to ground, positive current flowing into the pin (unless otherwise specified)

Parameter	Symbol	Values			Unit	Note or condition	P-Number
		Min.	Typ.	Max.			
CXPI communication nominal bit rate	B_{SYS}	4800	19200	20000	bps	1)	P_MXC_1_1

1) Not subject to production test, specified by design.

Table 49 Wake-up timing characteristics

$V_S = 5.5\text{ V to }18\text{ V}$, $T_J = -40^\circ\text{C to }+150^\circ\text{C}$, all voltages with respect to ground, positive current flowing into the pin (unless otherwise specified)

Parameter	Symbol	Values			Unit	Note or condition	P-Number
		Min.	Typ.	Max.			
Wake-up dominant pulse width (transmitting node)	t_{tx_wakeup}	400	–	2500	μs	1) $t_{bit} = 50\ \mu\text{s}$ $t_{txpwm_wakeup} = 8 \times t_{bit}$ and $t_{txpwm_wakeup} = 50 \times t_{bit}$ Refer to "Wake-Up Pulse Generated By Responder Node" timing diagrams.	P_MXC_2_1

1) Not subject to production test, specified by design.

29.7.1 Figures

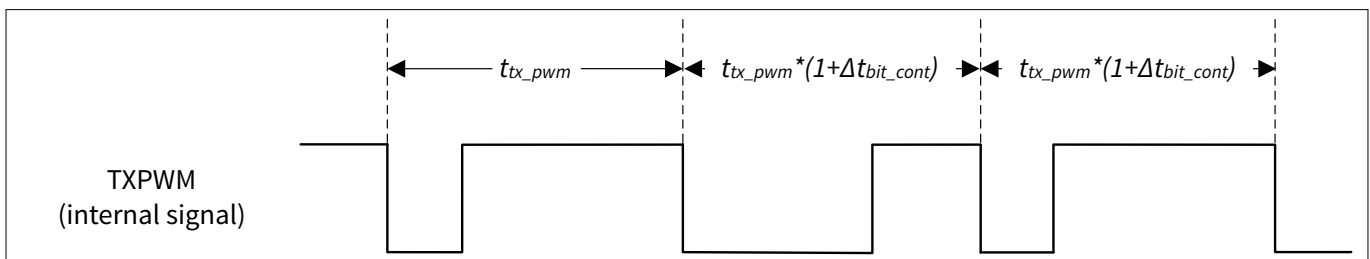

Figure 57 TXPWM falling edge transmitter jitter

29 Electrical characteristics

29.8 High-speed synchronous serial interface

29.8.1 SSC timing

The table below provides the SSC timing in the TLE9844QXC.

Table 50 SSC commander mode timing (operating conditions apply; $C_L = 50$ pF)

$V_S = 5.5$ V to 28 V, $T_j = -40^\circ\text{C}$ to $+150^\circ\text{C}$, all voltages with respect to ground, positive current flowing into pin (unless otherwise specified)

Parameter	Symbol	Values			Unit	Note or test condition	Number
		Min.	Typ.	Max.			
SCLK clock period	t_0	¹⁾ $2 \times T_{SSC}$	–	–		²⁾ $V_{DDP} > 2.7$ V	P_7.1.1
CTRR delay from SCLK	t_1	10	–	–	ns	²⁾ $V_{DDP} > 2.7$ V	P_7.1.2
CRRT setup to SCLK	t_2	10	–	–	ns	²⁾ $V_{DDP} > 2.7$ V	P_7.1.3
CRRT hold from SCLK	t_3	15	–	–	ns	²⁾ $V_{DDP} > 2.7$ V	P_7.1.4

- 1) $T_{SSCmin} = T_{CPU} = 1/f_{CPU}$. If $f_{CPU} = 20$ MHz, $t_0 = 100$ ns. T_{CPU} is the CPU clock period.
- 2) Not subject to production test, specified by design.

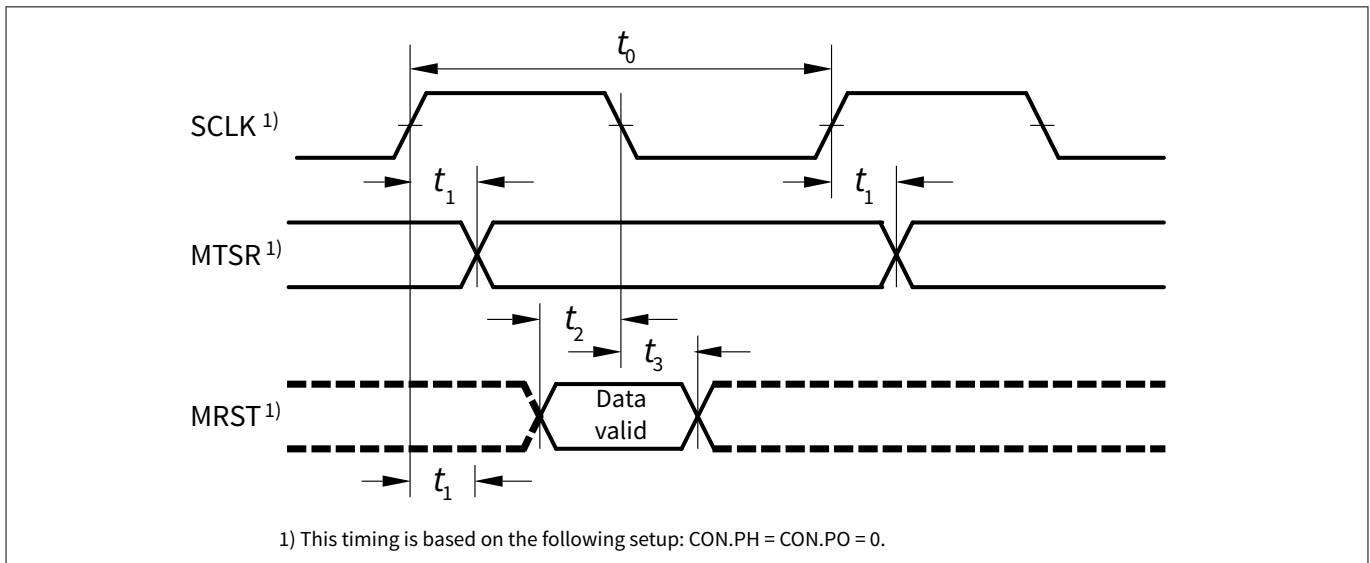

Figure 58 SSC commander mode timing

29 Electrical characteristics

29.9 Measurement unit

29.9.1 Electrical characteristics

Table 51 Supply voltage signal conditioning

$V_S = 5.5\text{ V to }28\text{ V}$, $T_j = -40^\circ\text{C to }+150^\circ\text{C}$, all voltages with respect to ground, positive current flowing into pin (unless otherwise specified)

Parameter	Symbol	Values			Unit	Note or test condition	Number
		Min.	Typ.	Max.			
ADC1 - battery/supply voltage measurement $V_{\text{BAT_SENSE}} / V_S$							
Input to output voltage attenuation: $V_{\text{BAT_SENSE}} / V_S$	$ATT_{V_{\text{BAT_SENSE}}}$, ATT_{V_S}	–	0.047	–		–	P_8.1.10
Nominal operating input voltage range $V_{\text{BAT_SENSE}} / V_S$	$V_{\text{BAT_SENSE, range}}$, $V_{S, range}$	0	–	25.77	V	²⁾ max. value corresponds to typ. ADC full scale input	P_8.1.11
Accuracy of $V_{\text{BAT_SENSE}} / V_S$ after calibration - with IIR filter	$\Delta V_{\text{BAT_SENSE_IIR}}$, V_{S_IIR}	-200	–	200	mV	$V_S = 5.5\text{ V to }18\text{ V}$, $f_{\text{ADCl}} = f_{\text{sys_max}}$ ADC1_FILTCOEFF0_11.C Hx = 11'b	P_8.1.12
Accuracy of $V_{\text{BAT_SENSE}} / V_S$ after calibration	$\Delta V_{\text{BAT_SENSE}}$, V_S	-300	–	300	mV	$V_S = 5.5\text{ V to }18\text{ V}$, $f_{\text{ADCl}} = f_{\text{sys_max}}$	P_8.1.36
ADC1 - monitoring input voltage measurement V_{MONx}							
Input to output voltage attenuation: V_{MONx}	$ATT_{V_{\text{MONx}}}$	–	0.039	–		–	P_8.1.13
Nominal operating input voltage range V_{MONx}	$V_{\text{MONx, range}}$	0	–	31.05	V	²⁾ max. value corresponds to typ. ADC full scale input	P_8.1.14
Accuracy of V_{MONx} sense after calibration - with IIR filter	$\Delta V_{\text{MONx_IIR}}$	-241	–	241	mV	$V_S = 5.5\text{ V to }18\text{ V}$, $f_{\text{ADCl}} = f_{\text{sys_max}}$ ADC1_FILTCOEFF0_11.C Hx = 11'b	P_8.1.33
Accuracy of V_{MONx} sense after calibration - Reduced Operating Range - with IIR filter	$\Delta V_{\text{MONx_ROR_IIR}}$	-170	–	170	mV	²⁾ $V_S = 5.5\text{ V to }18\text{ V}$, $V_{\text{MONx, range}} = 0\text{ V to }12\text{ V}$, $f_{\text{ADCl}} = f_{\text{sys_max}}$, ADC1_FILTCOEFF0_11.C Hx = 11'b	P_8.1.20
Accuracy of V_{MONx} sense after calibration	ΔV_{MONx}	-361	–	361	mV	²⁾ $V_S = 5.5\text{ V to }18\text{ V}$, $f_{\text{ADCl}} = f_{\text{sys_max}}$	P_8.1.37

(table continues...)

29 Electrical characteristics

Table 51 (continued) Supply voltage signal conditioning

$V_S = 5.5\text{ V to }28\text{ V}$, $T_j = -40^\circ\text{C to }+150^\circ\text{C}$, all voltages with respect to ground, positive current flowing into pin (unless otherwise specified)

Parameter	Symbol	Values			Unit	Note or test condition	Number
		Min.	Typ.	Max.			
ADC1 - port 2.x voltage measurement $V_{2.x}$							
Input to output voltage attenuation: $V_{\text{Port}2.x}$	$ATT_{2.x}$	–	0.219	–		–	P_8.1.15
Nominal operating input voltage range $V_{\text{Port}2.x}$	$V_{\text{Port}2.x,\text{range}}$	0	–	5.53 ¹⁾	V	²⁾ max. value corresponds to typ. ADC full scale input;	P_8.1.16
Accuracy of $V_{\text{Port}2.x}$ sense after calibration - with IIR filter	$\Delta V_{\text{Port}2.x,\text{IIR}}$	-43	–	43	mV	$V_S = 5.5\text{ V to }18\text{ V}$, $f_{\text{ADC1}} = f_{\text{sys_max}}$ ADC1_FILTCOEFF0_11.C Hx = 11'b	P_8.1.34
Accuracy of $V_{\text{Port}2.x}$ sense after calibration	$\Delta V_{\text{Port}2.x}$	-67	–	67	mV	$V_S = 5.5\text{ V to }18\text{ V}$, $f_{\text{ADC1}} = f_{\text{sys_max}}$	P_8.1.38
ADC2 - supply voltage measurement V_S							
Input to output voltage attenuation: V_S	$ATT_{V_S,\text{ADC2}}$	–	0.039	–		–	P_8.1.1
Nominal operating input voltage range V_S	$V_{S,\text{ADC2}}$	3	–	31.05	V	²⁾ max. value corresponds to typ. ADC full scale input; $3\text{ V} < V_S < 28\text{ V}$	P_8.1.2
Accuracy of V_S after calibration	$\Delta V_{S,\text{ADC2}}$	-270	–	270	mV	$V_S = 5.5\text{ V to }18\text{ V}$, $T_j = -40 \dots 125^\circ\text{C}$	P_8.1.3
ADC2 - VDDEXT voltage measurement V_{DDEXT}							
Input to output voltage attenuation: V_{DDEXT}	$ATT_{V_{\text{DDEXT}}}$	–	0.203	–		–	P_8.1.17
Nominal operating input voltage range V_{DDEXT}	$V_{\text{DDEXT},\text{range}}$	0	–	5.96	V	²⁾ max. value corresponds to typ. ADC full scale input	P_8.1.18
Accuracy of $V_{\text{DD_EXT}}$ sense after calibration	$\Delta V_{\text{DD_EXT}}$	-75	–	75	mV	$V_S = 5.5\text{ V to }18\text{ V}$, $T_j = 40 \dots 125^\circ\text{C}$	P_8.1.35

(table continues...)

29 Electrical characteristics

Table 51 (continued) Supply voltage signal conditioning

$V_S = 5.5\text{ V to }28\text{ V}$, $T_j = -40^\circ\text{C to }+150^\circ\text{C}$, all voltages with respect to ground, positive current flowing into pin (unless otherwise specified)

Parameter	Symbol	Values			Unit	Note or test condition	Number
		Min.	Typ.	Max.			
ADC2 - pad supply voltage measurement V_{VDDP}							
Input-to-output voltage attenuation: V_{VDDP}	ATT_{VDDP}	–	0.203	–		–	P_8.1.4
Nominal operating input voltage range V_{VDDP}	$V_{VDDP,range}$	0	–	5.96	V	²⁾ max. value corresponds to typ. ADC full scale input	P_8.1.5
Accuracy of V_{VDDP} sense after calibration V_{DD5_SENSE} ³⁾	ΔV_{DDP_SENSE}	-75	–	75	mV	$V_S = 5.5\text{ V to }18\text{ V}$, $T_j = 40 \dots 125^\circ\text{C}$	P_8.1.27
ADC2 - reference voltage measurement V_{VBG}							
Input-to-output voltage attenuation: V_{VBG}	ATT_{VBG}	–	0.75	–		–	P_8.1.6
Nominal operating input voltage range V_{VBG}	$V_{VBG,range}$	0.8	–	$V_{DDC} - 0.1\text{ V}$	V	²⁾ max. value corresponds to typ. ADC full scale input	P_8.1.7
Value of ADC2- V_{VBG} measurement after calibration	V_{VBG_PMU}	0.90	1.0	1.1	V	–	P_8.1.39
ADC2 - core supply voltage measurement V_{VDDC}							
Input-to-output voltage attenuation: V_{VDDC}	ATT_{VDDC}	–	0.75	–		–	P_8.1.8
Nominal operating input voltage range V_{VDDC}	$V_{VDDC,range}$	0.6	–	$V_{DDC} + 0.1\text{ V}$	V	²⁾ max. value corresponds to typ. ADC full scale input	P_8.1.9
Accuracy of V_{VDDC} sense after calibration V_{DD1} V_{S_SENSE}	ΔV_{DDC_SENSE}	-30	–	30	mV	$V_S = 5.5\text{ V to }18\text{ V}$, $T_j = 40 \dots 125^\circ\text{C}$	P_8.1.29
¹⁾ This typical theoretical full scale is not reached as the internal ESD Clamping Structure limits the voltage to max. 5.2 V. ²⁾ Not subject to production test, specified by design. ³⁾ Accuracy is valid for a calibrated device.							

29 Electrical characteristics

29.9.2 Central temperature sensor module

29.9.2.1 Electrical characteristics

Table 52 Electrical characteristics temperature sensor module

$V_S = 5.5\text{ V to }28\text{ V}$, $T_j = -40^\circ\text{C to }+150^\circ\text{C}$, all voltages with respect to ground, positive current flowing into pin (unless otherwise specified)

Parameter	Symbol	Values			Unit	Note or test condition	Number
		Min.	Typ.	Max.			
Output voltage V_{TEMP} at $T_0 = 0^\circ\text{C}$ (273 K) ²⁾	<i>a</i>	–	0.628	–	V	$T_0 = 0^\circ\text{C}$ (273 K)	P_8.2.1
Temperature sensitivity <i>b</i> ²⁾	<i>b</i>	–	2.31	–	mV/K	–	P_8.2.2
Accuracy_1	<i>Acc_1</i>	-10	–	10	°C	¹⁾ $-40^\circ\text{C} < T_j < 85^\circ\text{C}$	P_8.2.3
Accuracy_2	<i>Acc_2</i>	-15	–	15	°C	$125^\circ\text{C} < T_j < 175^\circ\text{C}$	P_8.2.4
Accuracy_3	<i>Acc_3</i>	-5	–	5	°C	²⁾ $85^\circ\text{C} < T_j < 125^\circ\text{C}$	P_8.2.5

1) Accuracy with reference to on-chip temperature calibration measurement.
 2) Not subject to production test, specified by design.

29 Electrical characteristics

29.10 ADC1 (10-bit)

29.10.1 ADC1 reference voltage

Table 53 DC specifications

$V_S = 5.5\text{ V to }28\text{ V}$, $T_j = -40^\circ\text{C to }+150^\circ\text{C}$, all voltages with respect to ground, positive current flowing into pin (unless otherwise specified)

Parameter	Symbol	Values			Unit	Note or test condition	Number
		Min.	Typ.	Max.			
Reference voltage	V_{BG}	-1%	1.211	+1%	V	-	P_9.1.10
Temperature drift	ΔV_{BG}	-1%	-	+1%	V	-	P_9.1.11

29.10.2 Electrical characteristics ADC1 (10-bit)

These parameters describe the conditions for optimum ADC performance.

Note: *Operating conditions apply.*

Table 54 A/D converter characteristics

$V_S = 5.5\text{ V to }28\text{ V}$, $T_j = -40^\circ\text{C to }+150^\circ\text{C}$; all voltages with respect to ground, positive current flowing into pin (unless otherwise specified)

Parameter	Symbol	Values			Unit	Note or test condition	Number
		Min.	Typ.	Max.			
Analog clock frequency	f_{ADCI}	5	-	40	MHz	¹⁾	P_9.2.1
DNL error	EA_{DNL}	-	-	± 2	LSB	²⁾	P_9.2.8
INL error	EA_{INL}	-	-	± 1.5	LSB	-	P_9.2.9
Gain error	EA_{GAIN}	-	-	± 0.54	% of FSR ³⁾	⁴⁾ calibrated; gain error is calibrated by implemented calibration unit	P_9.2.10
Offset error	EA_{OFF}	-	-	± 2.5	LSB	⁴⁾ calibrated; offset error is calibrated by implemented calibration unit	P_9.2.11
Total unadjusted error	EA_{TUE}	-	-	± 8	LSB	Already calibrated	P_9.2.33
Total unadjusted error, without filter	EA_{TUE_nofilt}	-	-	± 12.4	LSB	⁴⁾ already calibrated, without filter	P_9.2.35

(table continues...)

29 Electrical characteristics

Table 54 (continued) A/D converter characteristics

$V_S = 5.5\text{ V to }28\text{ V}$, $T_j = -40^\circ\text{C to }+150^\circ\text{C}$; all voltages with respect to ground, positive current flowing into pin (unless otherwise specified)

Parameter	Symbol	Values			Unit	Note or test condition	Number
		Min.	Typ.	Max.			
Input referred noise	$V_{\text{Noise_LSB}}$	–	–	1.5	LSB rms	4)	P_9.2.34
Cross-coupling attenuation between LV channels	EA_{CCOUP}	–	± 1	± 2	LSB	4)	P_9.2.12
Input capacitance of a HV analog input	$C_{\text{AINT_HVI}}$	–	–	200	fF	4)	P_9.2.13
Input capacitance of a LV analog input	$C_{\text{AINT_LVI}}$	–	–	200	fF	4)	P_9.2.19

- 1) The limit values for f_{ADC1} must not be exceeded when selecting the peripheral frequency and the prescaler setting.
- 2) This parameter is measured with disabled hardware calibration.
- 3) This gain error is calibrated by Infineon end of line.
- 4) Not subject to production test.

29 Electrical characteristics

29.11 High-voltage monitoring input

29.11.1 Electrical characteristics

Table 55 Electrical characteristics monitoring input

$V_S = 5.5\text{ V to }28\text{ V}$, $T_j = -40^\circ\text{C to }+150^\circ\text{C}$, all voltages with respect to ground, positive current flowing into pin (unless otherwise specified)

Parameter	Symbol	Values			Unit	Note or test condition	Number
		Min.	Typ.	Max.			
MON input pin characteristics							
Wake-up/monitoring threshold voltage	V_{MONth}	$0.4 \times V_S$	$0.5 \times V_S$	$0.6 \times V_S$	V	Without external serial resistor R_S (with $R_S: dV = I_{\text{PD/PU}} \times R_S$);	P_10.1.1
Threshold hysteresis	$V_{\text{MONth,hy s}}$	$0.015 \times V_S$	$0.06 \times V_S$	$0.10 \times V_S$	V	In all modes; without external serial resistor R_S (with $R_S: dV = I_{\text{PD/PU}} \times R_S$); $5.5\text{ V} < V_S < 18\text{ V}$	P_10.1.2
Threshold hysteresis-extended supply voltage range	$V_{\text{MONth,hy s_VS_extended}}$	$0.02 \times V_S$	$0.06 \times V_S$	$0.12 \times V_S$	V	In all modes; without external serial resistor R_S (with $R_S: dV = I_{\text{PD/PU}} \times R_S$); $18\text{ V} < V_S < 28\text{ V}$	P_10.1.7
Pull-up current	$I_{\text{PU, MON}}$	-20	-10	-5	μA	$0.6 \times V_S$	P_10.1.3
Pull-down current	$I_{\text{PD, MON}}$	5	10	20	μA	$0.4 \times V_S$	P_10.1.4
Input leakage current	$I_{\text{LK, MON}}$	-2	-	2	μA	$0\text{ V} < V_{\text{MON_IN}} < 28\text{ V}$	P_10.1.5
Timing							
Wake-up filter time	$t_{\text{FT, MON}}$	-	20	-	μs	1)	P_10.1.6

1) With pull-up, pull down current disabled.

29 Electrical characteristics

29.12 High side switches

29.12.1 Electrical characteristics

Table 56 Electrical characteristics

$V_S = 5.5\text{ V to }28\text{ V}$, $T_j = -40^\circ\text{C to }+150^\circ\text{C}$, all voltages with respect to ground, positive current flowing into pin (unless otherwise specified)

Parameter	Symbol	Values			Unit	Note or test condition	Number
		Min.	Typ.	Max.			
PWM frequency of HS with slew rate control	$f_{\text{PWM_W_SR}}$	0	–	10	kHz	¹⁾ Frequency must be configured in the PWM generator	P_11.1.1
PWM frequency of HS without slew rate control	$f_{\text{PWM_W/O_SR}}$	0	–	25 ²⁾	kHz	¹⁾ Frequency must be configured in the PWM generator	P_11.1.2

Output HS

ON-state resistance	R_{ON}	2	10	18	Ω	$5.5\text{ V} < V_S < 28\text{ V}$ $I_{\text{ds}} = 100\text{ mA}$ $T_j = 25^\circ\text{C}$	P_11.1.3
Output leakage current	I_{leakage}	–	–	2	μA	Output OFF $0\text{ V} < V_{\text{XLO}} < V_S$ $T_j \leq 150^\circ\text{C}$	P_11.1.4
Output slew rate (rising) with slow slew rate setting (slew rate 1)	$SR_{\text{raise_SR1}}$	1	–	10	$\text{V}/\mu\text{s}$	20% to 80% of V_S $V_S = 9\text{ to }18\text{ V}$ $R_L = 300\ \Omega$ ¹⁾	P_11.1.5
Output slew rate (falling) with slow slew rate setting (slew rate 1)	$SR_{\text{fall_SR1}}$	-10	–	-1	$\text{V}/\mu\text{s}$	80% to 20% of V_S $V_S = 9\text{ to }18\text{ V}$ $R_L = 300\ \Omega$ ¹⁾	P_11.1.6
Output slew rate (rising) with fast slew rate setting (slew rate 2)	$SR_{\text{raise_SR2}}$	18.0	–	55.0	$\text{V}/\mu\text{s}$	20% to 80% of V_S $V_S = 9\text{ to }18\text{ V}$ $R_L = 300\ \Omega$ ¹⁾	P_11.1.7
Output slew rate (falling) with fast slew rate setting (slew rate 2)	$SR_{\text{fall_SR2}}$	-43.4	–	-12.5	$\text{V}/\mu\text{s}$	80% to 20% of V_S $V_S = 9\text{ to }18\text{ V}$ $R_L = 300\ \Omega$ ¹⁾	P_11.1.8
Turn ON delay time (slew rate 1)	$t_{\text{IN-HS_SR1}}$	–	–	4.5	μs	ON = 1 to 20% of V_S $R_L = 300\ \Omega$	P_11.1.9
Turn ON time (slew rate 1)	$t_{\text{ON_SR1}}$	1	–	15	μs	$V_S = 9\text{ to }18\text{ V}$ HS_ON = 1 to 80% of V_S $R_L = 300\ \Omega$ $T_j = 25^\circ\text{C}$	P_11.1.10

(table continues...)

29 Electrical characteristics

Table 56 (continued) Electrical characteristics

$V_S = 5.5\text{ V to }28\text{ V}$, $T_j = -40^\circ\text{C to }+150^\circ\text{C}$, all voltages with respect to ground, positive current flowing into pin (unless otherwise specified)

Parameter	Symbol	Values			Unit	Note or test condition	Number
		Min.	Typ.	Max.			
Turn OFF time (slew rate 1)	$t_{\text{OFF_SR1}}$	1	–	15	μs	$V_S = 9\text{ to }18\text{ V}$ $\text{HS_ON} = 0\text{ to }20\%\text{ of }V_S$ $R_L = 300\ \Omega$ $T_j = 25^\circ\text{C}$	P_11.1.11
Turn ON delay time (slew rate 2)	$t_{\text{IN-HS_SR2}}$	–	–	1	μs	$\text{ON} = 1\text{ to }20\%\text{ of }V_S$ $R_L = 300\ \Omega$	P_11.1.55
Turn ON time (slew rate 2)	$t_{\text{ON_SR2}}$	–	–	3	μs	$V_S = 9\text{ to }18\text{ V}$ $\text{HS_ON} = 1\text{ to }80\%\text{ of }V_S$ $R_L = 300\ \Omega$ $T_j = 25^\circ\text{C}$	P_11.1.56
Turn OFF time (slew rate 2)	$t_{\text{OFF_SR2}}$	–	–	3	μs	$V_S = 9\text{ to }18\text{ V}$ $\text{HS_ON} = 0\text{ to }20\%\text{ of }V_S$ $R_L = 300\ \Omega$ $T_j = 25^\circ\text{C}$	P_11.1.57

Overcurrent detection

Overcurrent threshold 0	I_{octh0}	26	42	60	mA	$V_S = 13.5\text{ V}$ $\text{HSx_OC_SEL} = 00$	P_11.1.12
Overcurrent threshold 0 hysteresis	$I_{\text{octh0,hyst}}$	–	14	–	mA	¹⁾ $\text{HSx_OC_SEL} = 00$	P_11.1.13
Overcurrent threshold 1	I_{octh1}	51	60	80	mA	$V_S = 13.5\text{ V}$ $\text{HSx_OC_SEL} = 01$	P_11.1.14
Overcurrent threshold 1 hysteresis	$I_{\text{octh1,hyst}}$	–	17	–	mA	¹⁾ $\text{HSx_OC_SEL} = 01$	P_11.1.15
Overcurrent threshold 2	I_{octh2}	101	123	150	mA	$V_S = 13.5\text{ V}$ $\text{HSx_OC_SEL} = 10$	P_11.1.16
Overcurrent threshold 2 hysteresis	$I_{\text{octh2,hyst}}$	–	25	–	mA	¹⁾ $\text{HSx_OC_SEL} = 10$	P_11.1.17
Overcurrent threshold 3	I_{octh3}	151	176	210	mA	$V_S = 13.5\text{ V}$ $\text{HSx_OC_SEL} = 11$	P_11.1.18
Overcurrent threshold 3 hysteresis	$I_{\text{octh3,hyst}}$	–	30	–	mA	¹⁾ $\text{HSx_OC_SEL} = 11$	P_11.1.19

(table continues...)

29 Electrical characteristics

Table 56 (continued) Electrical characteristics

$V_S = 5.5\text{ V to }28\text{ V}$, $T_j = -40^\circ\text{C to }+150^\circ\text{C}$, all voltages with respect to ground, positive current flowing into pin (unless otherwise specified)

Parameter	Symbol	Values			Unit	Note or test condition	Number
		Min.	Typ.	Max.			
Overcurrent shutdown response time	t_{ocft}	8	–	80	μs	¹⁾ $V_S = 13.5\text{ V}$ $R_L = 100\ \Omega$, HS_ON to OC_SD (including switch-on time)	P_11.1.20
ON-state open load detection							
Open load threshold	I_{OLONth}	0.46	1.32	2.2	mA	–	P_11.1.21
Hysteresis	$I_{OLONhys}$	35	155	300	μA	–	P_11.1.22
Cyclic sense mode							
Current capability	$I_{HS\ max\ sleep_pd}$	40	–	–	mA	Sleep mode/stop mode	P_11.1.23
ON-State resistance	$R_{ON,static}$	–	–	40	Ω	$I_{ds} = 40\text{ mA}$	P_11.1.24
Output slew rate (rising)	SR_{rise_cyc}	1	–	–	V/ μs	20% to 80% of V_S $V_S = 9\text{ to }18\text{ V}$ $R_L = 300\ \Omega$	P_11.1.25
Output slew rate (falling)	SR_{fal_cycl}	–	–	-1	V/ μs	80% to 20% of V_S $V_S = 9\text{ to }18\text{ V}$ $R_L = 300\ \Omega$	P_11.1.26
Delay time CYCLIC_ON-HS	t_{IN_cyc}	–	–	2	μs	ON = 1 to 20% of V_S $R_L = 300\ \Omega$	P_11.1.27
Turn-ON time	t_{ON_cyc}	–	–	15	μs	$V_S = 9\text{ to }18\text{ V}$ ON = 1 to 80% $R_L = 300\ \Omega$	P_11.1.28
Turn-OFF time	t_{OFF_cyc}	–	–	15	μs	$V_S = 9\text{ to }18\text{ V}$ ON = 0 to 20% of V_S $R_L = 300\ \Omega$ $T_j = 25^\circ\text{C}$	P_11.1.29

1) Not subject to production test, specified by design.

2) This is an additional requirement which refers to a 47 Ω series resistor to charge an external power mos gate.

29 Electrical characteristics

29.13 Low-side switches

29.13.1 Electrical characteristics

Table 57 Electrical characteristics

$V_S = 5.5\text{ V to }28\text{ V}$, $T_j = -40^\circ\text{C to }+150^\circ\text{C}$, all voltages with respect to ground, positive current flowing into pin (unless otherwise specified)

Parameter	Symbol	Values			Unit	Note or test condition	Number
		Min.	Typ.	Max.			
PWM frequency of LS	f_{PWM}	–	–	25	kHz	¹⁾ $R_L = 270\ \Omega$	P_12.1.1
Output LS							
Overcurrent limitation	I_{LSTyp}	270	300	330	mA	–	P_12.1.2
ON-state resistance	R_{ON}	1	4	10	Ω	$I_{\text{ds}} = 100\text{ mA}$	P_12.1.3
Leakage current	I_{leakage}	–	–	2	μA	$0\text{ V} < V_{\text{LS}} < V_S$; $T_j < 85^\circ\text{C}$	P_12.1.5
Turn ON delay time, slow mode	$t_{\text{dOn-LS}}$	–	–	50	μs	²⁾ $\text{LS_ON} = 1\text{ to }0.9 \times V_S$; $V_S = 13.5\text{ V}, R_L = 270\ \Omega$	P_12.1.6
Turn ON delay time, PWM mode	$t_{\text{dOn,f-LS}}$	–	–	0.5	μs	$\text{LS_ON} = 1\text{ to }0.9 \times V_S$; $V_S = 13.5\text{ V}, R_L = 270\ \Omega$	P_12.1.7
Turn ON fall time, PWM mode	$t_{\text{ONf,PWM}}$	–	1	1.25	μs	$V_{\text{LS}} 0.9 \times V_S\text{ to }0.1 \times V_S$; $V_S = 13.5\text{ V}, R_L = 270\ \Omega$	P_12.1.8
Turn ON fall time, slow mode	$t_{\text{ONf,Slow}}$	–	100	150	μs	²⁾ $V_{\text{LS}} 0.9 \times V_S\text{ to }0.1 \times V_S$; $V_S = 13.5\text{ V}, R_L = 270\ \Omega$	P_12.1.9
Turn OFF delay time, slow mode	$t_{\text{dOff-LS}}$	–	–	50	μs	²⁾ $\text{LS_ON} = 0\text{ to }0.1 \times V_S$; $V_S = 13.5\text{ V}, R_L = 270\ \Omega$	P_12.1.10
Turn OFF delay time, PWM mode	$t_{\text{dOff,f-LS}}$	–	–	2	μs	$\text{LS_ON} = 0\text{ to }0.1 \times V_S$; $V_S = 13.5\text{ V}, R_L = 270\ \Omega$	P_12.1.11
Turn OFF rise time, PWM mode	$t_{\text{OFFr,PWM}}$	–	1	1.25	μs	$V_{\text{LS}} 0.1 \times V_S\text{ to }0.9 \times V_S$; $V_S = 13.5\text{ V}, R_L = 270\ \Omega$	P_12.1.12
Turn OFF rise time, slow mode	$t_{\text{OFFr,Slow}}$	–	100	150	μs	²⁾ $V_{\text{LS}} 0.1 \times V_S\text{ to }0.9 \times V_S$; $V_S = 13.5\text{ V}, R_L = 270\ \Omega$	P_12.1.13
Minimum duty cycle pulse width variation	ton_{MIN}	1.5	2	3.5	μs	$ton(\text{dig}) = 2\ \mu\text{s}^{\text{1)}$	P_12.1.14
Typical (systematic) pulse width increase LS_ON to VLS	$d\ ton_{\text{Typ}}$	–	1.25	–	μs	$ton(\text{dig}) = 2\ \mu\text{s}^{\text{1)}$	P_12.1.15
Zener clamp voltage	V_{AZ}	–	50	–	V	Values are valid at $T_j = 25^\circ\text{C}$	P_12.1.16
Clamping energy (repetitive)	E_{clamp}	–	–	2	mJ	^{1) 3)} 1.000.000 cycles, at $I_{\text{max}} = 90\text{ mA}$	P_12.1.17

(table continues...)

29 Electrical characteristics

Table 57 (continued) Electrical characteristics

$V_S = 5.5\text{ V to }28\text{ V}$, $T_j = -40^\circ\text{C to }+150^\circ\text{C}$, all voltages with respect to ground, positive current flowing into pin (unless otherwise specified)

Parameter	Symbol	Values			Unit	Note or test condition	Number
		Min.	Typ.	Max.			
Clamping energy	E_{clamp}	–	–	14	mJ	^{1) 3)} 10 cycles, $T_{\text{start}} = 25^\circ\text{C}$, at $I_{\text{max}} = 230\text{ mA}$	P_12.1.18
Clamping energy (single), hot	E_{clamp}	–	–	7	mJ	^{1) 3)} 10 cycles, $T_{\text{start}} = 85^\circ\text{C}$, at $I_{\text{max}} = 230\text{ mA}$	P_12.1.19

- 1) Not subject to production test, specified by design.
- 2) Static ON mode (no PWM).
- 3) Valid for one low-side, not for both at the same time.

30 Package information

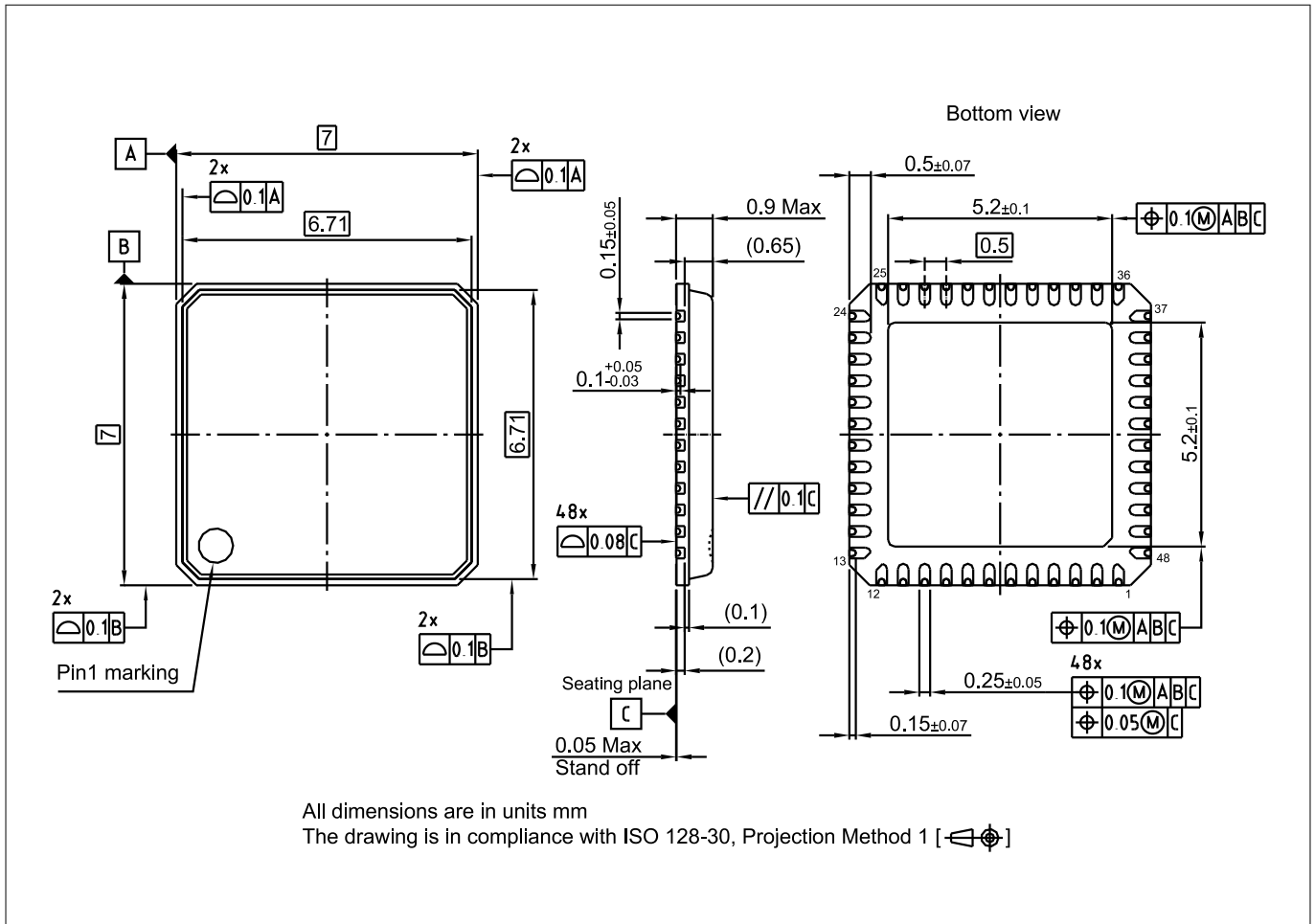

Figure 60 Package outline VQFN-48-79⁴⁾

Green product (RoHS compliant)

To meet the world-wide customer requirements for environmentally friendly products and to be compliant with government regulations the device is available as a green product. Green products are RoHS-compliant (that is Pb-free finish on leads and suitable for Pb-free soldering according to IPC/JEDEC J-STD-020).

Further information on packages

<https://www.infineon.com/packages>

⁴ Dimensions in mm.

31 Abbreviations

31 Abbreviations

The following acronyms and terms are used within this document.

Table 58 Acronyms

Acronyms	Name
AHB	Arm® advanced high-performance bus
CCU6	Capture compare unit 6
CGU	Clock generation unit
CLKMU	Clock management unit
CMU	Cyclic management unit
CRRT	Commander receive/responder transmit, corresponds to MISO in SPI
CTRR	Commander transmit/responder receive, corresponds to MOSI in SPI
CXPI	Clock eXtension Peripheral Interface
DPP	Data post processing
ECC	Error correction code
EEPROM	Electrically erasable programmable read only memory
GPIO	General purpose input output
HV	High voltage
ICU	Interrupt control unit
LDO	Low dropout voltage regulator
LIN	Local interconnect network
LSB	Least significant bit
LTI	Lead tip inspection
LV	Low voltage
MCU	Microcontroller unit
MF	Measurement functions
MPU	Memory protection unit
MSB	Most significant bit
MU	Measurement unit
NMI	Non-maskable interrupt
NVIC	Nested vector interrupt controller
OSC	Oscillator
OTP	One time programmable
PBA	Peripheral bridge
PC	Program counter
PCU	Power control unit

(table continues...)

31 Abbreviations

Table 58 (continued) Acronyms

Acronyms	Name
PD	Pull down
PGU	Power supply generation unit
PLL	Phase locked loop
PMU	Power management unit
PPB	Private peripheral bus
PSW	Program status word
PU	Pull up
PWM	Pulse width modulation
RAM	Random access memory
RCU	Reset control unit
rfu	Reserved for future use
RMU	Reset management unit
ROM	Read only memory
SCU	System control unit
SOW	Short open window (for WDT1)
SPI	Serial peripheral interface
SSC	Synchronous serial channel
SWD	Arm® serial wire debug
TCCR	Temperature compensation control register
TMS	Test mode select
TSD	Thermal shut down
UART	Universal asynchronous receiver transmitter
VBG	Voltage reference band gap
VCO	Voltage controlled oscillator
WDT1	Watchdog timer in SCU-PM (system control unit – power modules)
WMU	Wake-up management unit
100TP	100 times programmable

32 Revision history

32 Revision history

Document version	Date of release	Description of changes
Rev. 1.1	2025-09-15	Added note for Figure 27 Added package VQFN-48-37
Rev. 1.0	2024-01-15	Initial revision

Trademarks

All referenced product or service names and trademarks are the property of their respective owners.

Edition 2025-09-15

Published by

Infineon Technologies AG

81726 Munich, Germany

© 2025 Infineon Technologies AG

All Rights Reserved.

Do you have a question about any aspect of this document?

Email: erratum@infineon.com

Document reference

IFX-Z8F70838971

Important notice

The information given in this document shall in no event be regarded as a guarantee of conditions or characteristics ("Beschaffheitsgarantie").

With respect to any examples, hints or any typical values stated herein and/or any information regarding the application of the product, Infineon Technologies hereby disclaims any and all warranties and liabilities of any kind, including without limitation warranties of non-infringement of intellectual property rights of any third party.

In addition, any information given in this document is subject to customer's compliance with its obligations stated in this document and any applicable legal requirements, norms and standards concerning customer's products and any use of the product of Infineon Technologies in customer's applications.

The data contained in this document is exclusively intended for technically trained staff. It is the responsibility of customer's technical departments to evaluate the suitability of the product for the intended application and the completeness of the product information given in this document with respect to such application.

Warnings

Due to technical requirements products may contain dangerous substances. For information on the types in question please contact your nearest Infineon Technologies office.

Except as otherwise explicitly approved by Infineon Technologies in a written document signed by authorized representatives of Infineon Technologies, Infineon Technologies' products may not be used in any applications where a failure of the product or any consequences of the use thereof can reasonably be expected to result in personal injury.