

Features

- Eight half-bridge gate drivers for external N-channel MOSFETs
- Control of reverse battery protection MOSFET
- Adaptive MOSFET gate control
 - Improved electromagnetic emission
 - Reduced switching losses in PWM mode
- 24-bit Serial Peripheral Interface
- Two current sense amplifiers with configurable gain
 - High-side and low-side capable for protection and diagnosis
- Drain-source monitoring for short circuit detection
- Overtemperature warning and shutdown
- Timeout watchdog
- Detailed off-state diagnostic (open load, short circuit to battery or short circuit to GND) via SPI
- Three PWM inputs
 - High-side and low-side PWM capable
 - Active free-wheeling
 - Up to 25 kHz PWM frequency
- Low current consumption in sleep mode
- Configurable low-side 1-4 brake with short circuit detection in sleep mode and normal mode
- Configurable VS overvoltage detection in sleep mode
- Leadless power package with support of optical lead tip inspection
- Green Product (RoHS compliant)
- AEC Qualified

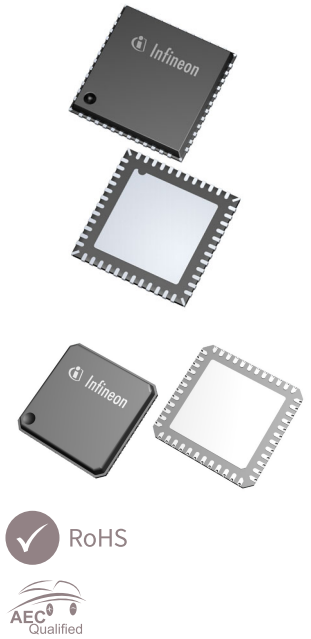

Potential applications

- Seat control and extended functions (steering column adjustment, gas pedal adjustment)
- Power lift gate
- Central door lock
- Body control module (cargo cover, washer pump, window lift, rear wiper ...)

Product validation

Qualified for automotive applications. Product validation according to AEC-Q100.

Description

The TLE92108-232QX is a Multi-MOSFET driver IC dedicated to control up to sixteen n-channel MOSFETs. It includes eight half-bridges for DC motor control applications such as automotive power seat control or other applications.

A 24-bit Serial Peripheral Interface (SPI) is used to configure the TLE92108-232QX and to control the half-bridges. It also allows the read out of the status registers for diagnostic purpose.

The TLE92108-232QX offers a wide range of diagnostic features such as the monitoring of the supply voltage, the charge pump voltage, temperature warning and over-temperature shutdown. Each gate driver monitors independently its external MOSFET drain-source voltage for fault conditions.

The device is housed in a VQFN-48 with exposed pad supporting lead tip inspection. The package provides a good thermal performance and minimizes the required PCB space.

Type	Package	Marking
TLE92108-232QX	PG-VQFN-48	TLE92108-232QX

Table of contents

	Features	1
	Potential applications	1
	Product validation	1
	Description	1
	Table of contents	2
1	Block diagram	6
1.1	Voltage and current definition	7
2	Pin configuration	8
2.1	Pin assignment	8
2.2	Pin definitions and functions	9
3	General product characteristics	11
3.1	Absolute maximum ratings	11
3.2	Functional range	12
3.3	Thermal resistance	14
4	General description	15
4.1	Power supply	15
4.2	Operation modes	15
4.2.1	Normal mode	16
4.2.2	Sleep mode	16
4.2.3	Fail Safe Mode	16
4.3	Reset behavior	17
4.4	Charge pump	18
4.5	Frequency modulation	18
4.6	Electrical characteristics	19
4.6.1	Electrical characteristics: supply	19
4.6.2	Electrical characteristics: logic inputs PWMx, EN	22
4.6.3	Electrical characteristics charge pump	23
5	Floating gate drivers	24
5.1	MOSFET control with bridge driver in active mode (BD_PASS = 0 and EN = High)	26
5.2	Static activation with bridge driver in active mode (BD_PASS = 0)	26
5.2.1	Static activation of a high-side MOSFET	27
5.2.2	Static activation of a low-side MOSFET	30
5.2.3	Turn-off of the high-side and low-side MOSFETs of a half-bridge	30
5.3	PWM operation with bridge driver in active mode (BD_PASS = 0)	31
5.3.1	Determination of the active and free-wheeling MOSFET	32
5.3.2	Configuration in PWM mode	34
5.3.3	PWM operation with adaptive gate control	36

5.3.3.1	High-side PWM with adaptive gate control, motor operating as load	38
5.3.3.2	Low-side PWM with adaptive gate control, motor operating as load	43
5.3.3.3	High-side PWM with adaptive gate control, motor operating as generator	44
5.3.3.4	Low-side PWM with adaptive gate control, motor operating as generator	46
5.3.3.5	Status bits for regulation of turn-on and turn-off delay times	48
5.3.3.6	Precharge and predischage phases with <code>EN_DEEP_AD = 1</code>	48
5.3.4	PWM operation without adaptive gate control	51
5.3.4.1	PWM operation without adaptive gate control, <code>AGC[1:0] = (0,0)</code>	51
5.3.4.2	PWM operation without adaptive gate control, <code>AGC[1:0] = (0,1)</code>	52
5.3.5	PWM operation at high and low duty cycles	54
5.3.6	Gate driver current	57
5.4	Passive discharge	61
5.5	Bridge driver in passive mode	61
5.6	Electrical characteristics gate driver	62
6	Protections and diagnostics	65
6.1	Reverse polarity protection	65
6.2	Safe switch (optional)	65
6.3	Drain-source voltage monitoring with bridge driver in active mode	65
6.4	Drain-source voltage monitoring with bridge driver in passive mode	66
6.5	Cross-current protection and drain-source overvoltage blank time	67
6.5.1	Cross-current protection	67
6.5.2	Drain-source overvoltage blank time in bridge driver active mode	67
6.5.3	Mapping of cross-current protection and blank times	70
6.6	OFF-state diagnostic	70
6.7	Temperature monitoring	71
6.8	V_S overvoltage and undervoltage shutdown	72
6.8.1	V_S undervoltage	72
6.8.2	V_S overvoltage with bridge driver in active mode	72
6.8.3	V_S overvoltage with bridge driver in passive mode	73
6.8.4	V_{DD} undervoltage	73
6.8.5	Charge pump undervoltage	73
6.9	Switching parameters of MOSFETs in PWM mode	74
6.10	Timeout watchdog	74
6.11	Current sense amplifier	75
6.11.1	Unidirectional and bidirectional operation	76
6.11.2	Gain configuration	76
6.11.3	High-side and low-side setting	76
6.11.4	Overcurrent detection	77
6.11.5	CSO outputs capacitor	78
6.12	Electrical characteristics protections and diagnostics	79
7	Serial Peripheral Interface - SPI	85

7.1	SPI protocol with independent slave selection	85
7.2	Global Error Flag (GEF)	87
7.3	Global status byte	87
7.4	SPI error detection	89
7.5	Daisy chain	90
7.6	SPI electrical characteristics: timings	93
8	Register specification	96
8.1	Control registers	96
8.1.1	General Control Registers and Protection Settings	97
8.1.1.1	General control register 1	97
8.1.1.2	General control register 2	98
8.1.1.3	Drain-source monitoring threshold HB1-4	100
8.1.1.4	Drain-source monitoring threshold HB5-8	102
8.1.1.5	Cross current protection and blank time setting 1	103
8.1.1.6	Cross current protection and blank time setting 2 for active MOSFETs	104
8.1.1.7	Cross current protection and blank time setting 2 for FW MOSFETs	106
8.1.2	Half-bridge control	108
8.1.2.1	Half-bridge mode	108
8.1.2.2	PWM channel settings	109
8.1.2.3	PWM pre-charge and pre-discharge time	110
8.1.2.4	Half-bridge diagnostic current control	112
8.1.2.5	Static charge and discharge current selection	113
8.1.2.6	PWM Active MOSFET precharge current initialization	115
8.1.2.7	PWM charge current of active MOSFETs	115
8.1.2.8	PWM charge/discharge currents of FW MOSFETs	116
8.1.2.9	PWM discharge current for active MOSFETs	117
8.1.2.10	PWM Active MOSFET pre-discharge current initialization	117
8.1.2.11	PWM maximum drive current selection and active tCCP4, tBLANK 3/4	118
8.1.2.12	PWM maximum drive current selection and FW tCCP4, tBLANK 3/4	119
8.1.2.13	Selection MOSFET turn-on and turn-off delay for PWM channel 1	120
8.1.2.14	Selection MOSFET turn-on and turn-off delay for PWM channel 2	120
8.1.2.15	Selection MOSFET turn-on and turn-off delay for PWM channel 3	121
8.2	Status register	122
8.2.1	General status register	122
8.2.2	Drain-Source Overvoltage 1	124
8.2.3	Half-bridge Output Voltage Status	125
8.2.4	Effective MOSFET turn-on and turn-off delay of PWM1	127
8.2.5	Effective MOSFET turn-on and turn-off delay of PWM2	128
8.2.6	Effective MOSFET turn-on and turn-off delay of PWM3	128
8.2.7	Effective MOSFET rise and fall times of PWM channel 1	129
8.2.8	Effective MOSFET rise and fall times of PWM channel 2	129
8.2.9	Effective MOSFET rise and fall times of PWM channel 3	130

8.2.10	Device Identifier	130
9	Application information	131
10	Package outlines	133
11	Revision History	134
	Disclaimer	135

1 Block diagram

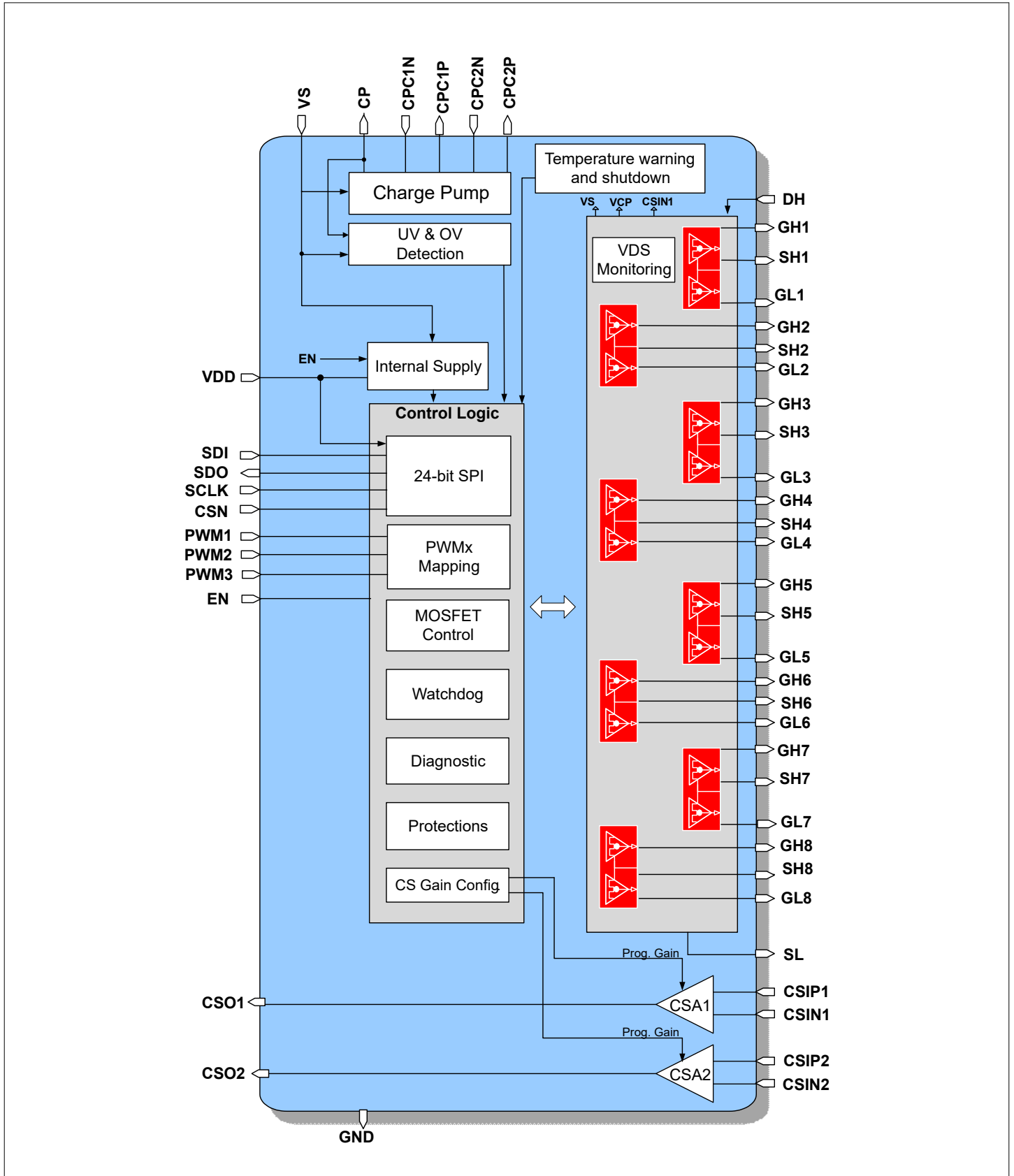

Figure 1 Block diagram

1.1 Voltage and current definition

Figure 2 shows terms used in this datasheet, with associated convention for positive value.

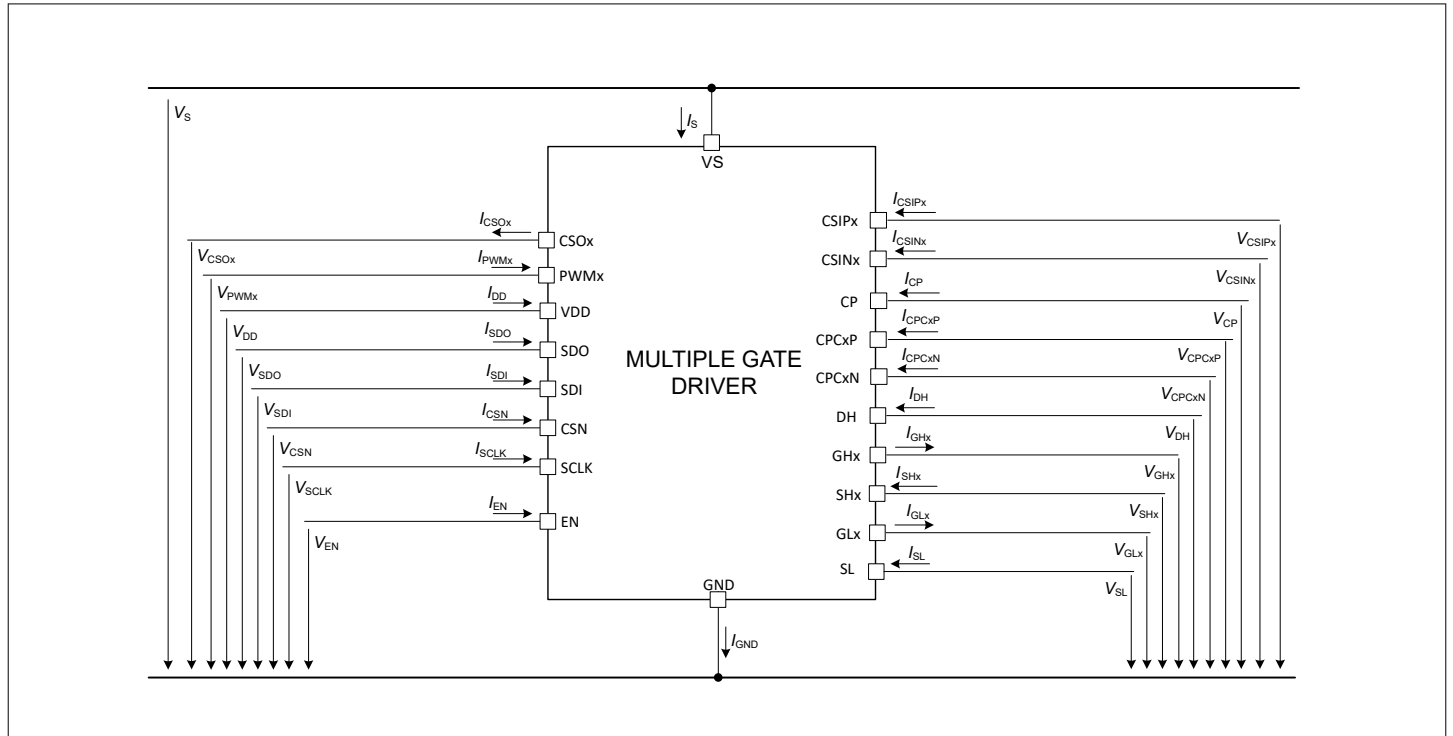

Figure 2 Voltage and current definition

2 Pin configuration

2.1 Pin assignment

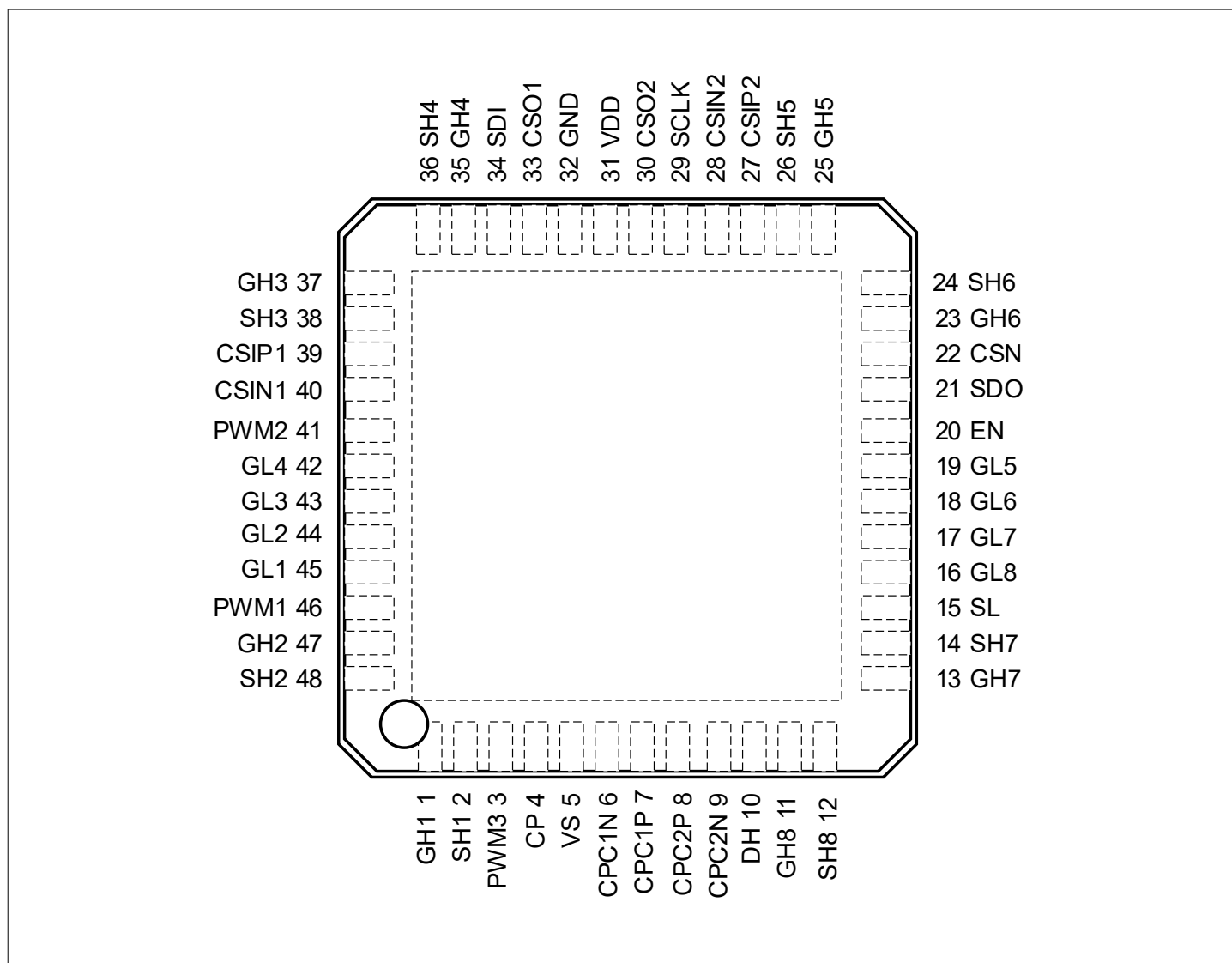

Figure 3 Pin configuration TLE92108-232QX

2.2 Pin definitions and functions

Table 1 Pin configuration TLE92108-232QX

Pin	Symbol	Function
1	GH1	Gate high-side 1 Analog I/O pin to turn on/off high-side MOSFET 1. Connect to the gate of high-side MOSFET 1.
2	SH1	Source high-side 1 Connection to source of high-side MOSFET 1.
3	PWM3	PWM input 3
4	CP	Charge Pump Output
5	VS	Supply Voltage Device supply voltage. Connect this pin to the supply (battery) voltage with a reverse battery protection circuit.
6	CPC1N	Negative connection to Charge Pump Capacitor 1
7	CPC1P	Positive connection to Charge Pump Capacitor 1
8	CPC2P	Positive connection to Charge Pump Capacitor 2
9	CPC2N	Negative connection to Charge Pump Capacitor 2
10	DH	Drain input for high-sides Input for the drains of high-side MOSFETs. Refer to Chapter 6.3 .
11	GH8	Gate high-side 8
12	SH8	Source high-side 8
13	GH7	Gate high-side 7
14	SH7	Source high-side 7
15	SL	Source low-side Common connection to the source of the low-side MOSFETs.
16	GL8	Gate low-side 8
17	GL7	Gate low-side 7
18	GL6	Gate low-side 6
19	GL5	Gate low-side 5
20	EN	Enable input with internal pull-down
21	SDO	Serial Data Output
22	CSN	Chip Select Not with internal pull-up
23	GH6	Gate high-side 6
24	SH6	Source high-side 6
25	GH5	Gate high-side 5
26	SH5	Source high-side 5
27	CSIP2	Non-Inverting input of the Current Sense Amplifier 2

(table continues...)

2 Pin configuration

Table 1 (continued) Pin configuration TLE92108-232QX

Pin	Symbol	Function
28	CSIN2	Inverting input of the Current Sense Amplifier 2
29	SCLK	Serial Clock Input with internal pull-down
30	CSO2	Current Sense Amplifier Output 2
31	VDD	Logic supply
32	GND	Ground connection
33	CSO1	Current Sense Amplifier Output1
34	SDI	Serial Data Input with internal pull-down
35	GH4	Gate high-side 4
36	SH4	Source high-side 4
37	GH3	Gate high-side 3
38	SH3	Source high-side 3
39	CSIP1	Non-inverting input of the Current Sense Amplifier 1
40	CSIN1	Inverting input of the Current Sense Amplifier 1 . This pin can be used as reference for the high-side MOSFET drain if CSA1 is configured as high-side. Refer to Chapter 6.3
41	PWM2	PWM input 2
42	GL4	Gate low-side 4
43	GL3	Gate low-side 3
44	GL2	Gate low-side 2
45	GL1	Gate low-side 1
46	PWM1	PWM input 1
47	GH2	Gate high-side 2
48	SH2	Source high-side 2
	E.P.	Exposed pad For cooling purpose only, do not use as electrical GND ¹⁾ .

1) The exposed pad at the bottom of the package allows better power dissipation from TLE92108-232QX via the PCB. The exposed pad must be left floating or connected to GND (recommended) for best EMC and thermal performance.

3 General product characteristics

3.1 Absolute maximum ratings

Table 2 Absolute maximum ratings¹⁾

T_j = -40°C to 150°C; all voltages with respect to ground, positive current flowing into pin (unless otherwise specified)

Parameter	Symbol	Values			Unit	Note or Test Condition	Number
		Min.	Typ.	Max.			
Voltages							
Supply voltage	V _S	-0.3	–	40	V	–	P_4.1.1
PWM input voltages (PWMx)	V _{PWMx}	-0.3	–	V _{DD} + 0.3	V	I < 10 mA	P_4.1.2
Logic input voltages (SDI, SCLK, CSN, EN)	V _{SDI} , V _{SCLK} , V _{CSN} , V _{EN}	-0.3	–	V _{DD} + 0.3	V	I < 10 mA	P_4.1.3
Voltage range and SDO	V _{SDO}	-0.3	–	V _{DD} + 0.3	V	I < 10 mA	P_4.1.4
Voltage range at CSIPx and CSINx	V _{CSIP} , V _{CSIN}	-8.0	–	40	V	–	P_4.1.5
Differential input voltage range CSIPx - CSINx	V _{CSIDiff}	-8.0	–	8.0	V	–	P_4.1.21
Voltage range at DH	V _{DH}	-0.3	–	40	V	–	P_4.1.6
Voltage range at SL	V _{SL}	-8.0	–	6.0	V	–	P_4.1.7
Voltage range at SHx	V _{SH}	-8.0	–	48	V	–	P_4.1.8
Voltage range at GHx	V _{GH}	-8.0	–	48	V	–	P_4.1.9
Voltage range at GLx	V _{GL}	-8.0	–	24	V	–	P_4.1.10
Voltage difference between GLx and SL	V _{GS_LS}	-0.3	–	16	V	–	P_4.1.11
Voltage difference between GHx and SHx	V _{GS_HS}	-1.0	–	16	V	2)	P_4.1.23
Voltage range at charge pump pins CP	V _{CP}	V _S - 0.3	–	V _S + 17	V	–	P_4.1.12
Voltage range at charge pump pins CPC1P, CPC2P	V _{CPCxP}	-0.3	–	V _S + 17	V	–	P_4.1.22
Voltage range at charge pump pins CPC1N, CPC2N	V _{CPCxN}	-0.3	–	V _S + 0.3	V	–	P_4.1.24
Logic supply voltage	V _{DD}	-0.3	–	5.5	V	–	P_4.1.13
Voltage at CSOx	V _{CSOx}	-0.3	–	V _{DD} + 0.3	V	–	P_4.1.14

Temperatures

Junction temperature	T _j	-40	–	150	°C	–	
----------------------	----------------	-----	---	-----	----	---	--

(table continues...)

Table 2 (continued) Absolute maximum ratings¹⁾

$T_j = -40^\circ\text{C}$ to 150°C ; all voltages with respect to ground, positive current flowing into pin (unless otherwise specified)

Parameter	Symbol	Values			Unit	Note or Test Condition	Number
		Min.	Typ.	Max.			
Storage temperature	T_{stg}	-55	–	150	$^\circ\text{C}$	–	P_4.1.16
ESD susceptibility							
ESD susceptibility all pins	V_{ESDHBM1}	-2	–	2	kV	HBM ³⁾	P_4.1.17
ESD susceptibility of VS and DH pins versus GND	V_{ESDHBM2}	-4	–	4	kV	HBM ³⁾	P_4.1.18
ESD susceptibility all pins	V_{ESDCDM1}	-500	–	500	V	CDM ⁴⁾	P_4.1.19
ESD susceptibility pin corner pins	V_{ESDCDM2}	-750	–	750	V	CDM ⁴⁾	P_4.1.20

1) Not subject to production test, specified by design.

2) $V_{\text{GS_GH}}$ may be between -1.0 and -0.3V only if the current injected into SHx is below 4 mA

3) ESD susceptibility, HBM according to ANSI/ESDA/JEDEC JS001 (1.5 k Ω , 100 pF).

4) ESD susceptibility, Charged Device Model “CDM” according JEDEC JESD22-C101.

Notes:

1. Stresses above the ones listed here may cause permanent damage to the device. Exposure to absolute maximum rating conditions for extended periods may affect device reliability.
2. Integrated protection functions are designed to prevent IC destruction under fault conditions described in the data sheet. Fault conditions are considered as “outside” normal operating range. Protection functions are not designed for continuous repetitive operation.

3.2 Functional range

Table 3 Functional range

Parameter	Symbol	Values			Unit	Note or Test Condition	Number
		Min.	Typ.	Max.			
Supply voltage range for normal operation	$V_{\text{S(nor)}}$	6.0	–	28	V	–	P_4.2.1
Extended supply voltage range	$V_{\text{S(ext)}}$	5.5	–	6	V	¹⁾ Parameter deviations possible	P_4.2.7
Extended supply voltage range	$V_{\text{S(ext)}}$	28	–	$V_{\text{SOV_OFF2}}$ (max)	V	¹⁾ Parameter deviations possible	P_4.2.2
Supply voltage transients slew rate	dV_{S}/dt	-10	–	10	V/ μs	¹⁾	P_4.2.3
Logic supply voltage	V_{DD}	3.0	–	5.5	V	–	P_4.2.4
SPI logic input voltage	V_{SDI} , V_{SCLK} , V_{CSN}	0	–	V_{DD}	V	–	P_4.2.5
Junction temperature	T_j	-40	–	150	$^\circ\text{C}$	–	P_4.2.6

1) Not subject to production test, specified by design.

Note: *Within the functional or operating range, the IC operates as described in the circuit description. The electrical characteristics are specified within the conditions given in the Electrical Characteristics table.*

3.3 Thermal resistance

Note: This thermal data was generated in accordance with JEDEC JESD51 standards. For more information, go to www.jedec.org.

Table 4 Thermal resistance

Parameter	Symbol	Values			Unit	Note or Test Condition	Number
		Min.	Typ.	Max.			
Junction to case	R_{thJC}	–	4.4	–	K/W	1)	
Junction to ambient	R_{thJA}	–	27	–	K/W	1) 2)	

1) Not subject to production test, specified by design.

2) Specified R_{thJA} value is according to Jedec JESD51-2,-5,-7 at natural convection on FR4 2s2p board; The Product (Chip+Package) was simulated on a 76.2 × 114.3 × 1.5 mm board with 2 inner copper layers (2 × 70 mm Cu, 2 × 35 mm Cu). Where applicable a thermal via array under the exposed pad contacted the first inner copper layer.

4 General description

4.1 Power supply

The Multiple MOSFET Driver IC requires two power supplies: V_S and V_{DD} .

V_{DD} supplies the I/O buffers (including the SPI pins) and the internal voltage regulator for the logic. V_{DD} allows the flexibility of a 3.3 V or a 5.0 V logic interface.

V_S supplies the charge pump for the MOSFET gate drivers. The V_S pin must be connected to the battery through a reverse battery protection.

Both supplies are separated so that the information stored in the logic remains intact in the event of voltage drop on V_S . V_{DD} and V_S should be decoupled with ceramic capacitors connected close to the supply and ground planes.

4.2 Operation modes

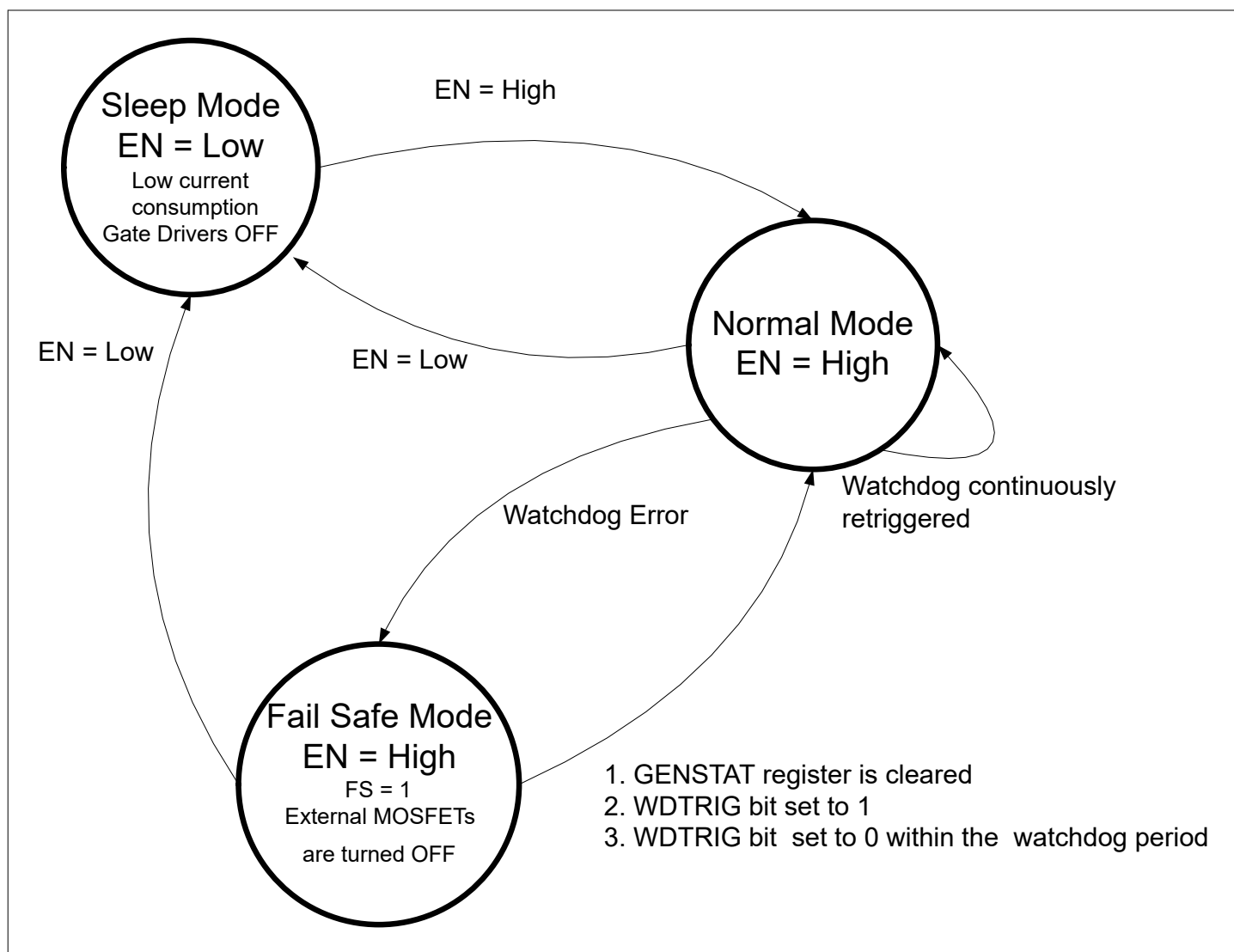

Figure 4 State diagram

Note: The state diagram is valid for V_S and V_{DD} within the nominal operating range. For V_S and V_{DD} outside of the nominal range, refer to [Chapter 6.8](#), respectively [Chapter 4.2.2](#).

4.2.1 Normal mode

The TLE92108-232QX enters Normal Mode by setting EN pin to High and waiting for the SPI setup time t_{SET_SPI} . In normal mode, the MOSFET gate drivers are enabled and can be configured through the SPI interface, provided that the voltages applied to V_{DD} and V_S are within the operating range. The watchdog must be retriggered correctly in order to stay in Normal Mode (see [Chapter 6.10](#)).

4.2.2 Sleep mode

The Multiple MOSFET Driver IC enters Sleep Mode by setting EN pin to Low. The transition to the sleep mode is delayed by $t_{DSLEEP}^{1)}$ (max tCCP of active half-bridges + 3 μ s) in order to actively turn-off the external MOSFETs. In this mode, the internal regulator and the internal circuitry are deactivated, and the SPI registers are reset. The current consumption of V_{DD} is reduced to IDD_Q . The current consumption of V_S is reduced to ISQ or $ISQ + ISQ_BRAKE$.

The V_S current consumption is ISQ if:

- $PASS_MOD = 00_B$ and $PASS_VDS = 0_B$ while entering sleep mode
- and V_S never drops below $VSLEEP_SET$ after entering sleep mode

The V_S current consumption is $ISQ + ISQ_BRAKE$ if:

- $PASS_MOD = 01_B, 10_B, 11_B$ or $PASS_VDS = 1_B$ while entering sleep mode
- or V_S has recovered from a voltage below $VSLEEP_SET$ (i.e. V_S has ramped up from a voltage below $VSLEEP_SET$ or V_S has dropped below $VSLEEP_SET$)

The internal resistors R_{GGND} between GHx/GLx and GND are activated to discharge the gate of the external MOSFETs.

Note: If EN is set to Low for a duration shorter than (t_{ENL_FILT} , 8 μ s max.), and EN is set to High again, then device does not go in sleep mode and the registers are not reset. The half-bridges are reactivated according to the settings of the control registers when EN is High.

4.2.3 Fail Safe Mode

In case of watchdog error (see [Chapter 6.10](#)), the device enters Fail Safe Mode, FS bit is set (see [Global status byte](#)) and the external MOSFETs are actively discharged with the static discharge current ([Chapter 5.2](#)) during the max. configured t_{HBxCCP} active ([Chapter 6.5.1](#)). Then the bridge driver is set to passive mode (the passive discharge path is activated, [Chapter 5.4](#), all external MOSFETs are latched off, and the charge pump is deactivated). To resume Normal Mode the microcontroller must execute the following sequence²⁾:

1. Clear [GENSTAT](#) register.
2. Write WDTRIG bit to 1 ([GENCTRL1](#)) within the watchdog period.
3. Write WDTRIG bit to 0 within the watchdog period³⁾.

In fail safe mode, the control registers are frozen to their default value, at the exception of [WDTRIG](#), [CCSO](#), [PASS_VDS](#), [PASS_MOD](#), [CSA1L](#), [CSA2L](#). Any write command (except for WDTRIG bit) or clear command (except for GENSTAT) will be discarded in this mode and sets SPIE bit ([Global status byte](#)).

A clear command to [GENSTAT](#) in fail safe mode does not reset any failure flag reported by this status register.

The control and status registers can be read in this mode before the start of the exit sequence without SPIE bit being set.

¹ SPI Frames are ignored during t_{DSLEEP} .

² The exit sequence must be strictly followed to leave fail safe mode. If a SPI frame not belonging to the sequence is added, then the device stays in fail safe mode and the microcontroller must restart the complete sequence to enter normal mode.

³ During Fail Safe Mode, the charge pump is deactivated and [CPUV](#) is set. Therefore, recovering from Fail Safe Mode, [GENSTAT](#) must be cleared again at the end of the Fail Safe exit sequence to re-activate of the gate drivers.

4.3 Reset behavior

The following events trigger a Power On Reset:

V_{DD} undervoltage reset:

If $V_{DD} < V_{DD\ PoffR}$ the digital block is deactivated and the outputs are switched off. The digital block is reset once $V_{DD} > V_{DD\ POR}$. Then NPOR bit (negated power-on reset bit, see [Global status byte](#)) is reset to 0 to report the reset condition.

Reset on EN pin:

If the EN pin is pulled low, the logic content is reset and the device enters sleep mode. Once the device enters Normal Mode (after [tSET_SPI](#) with EN = high and $V_{DD} > V_{DD\ POR}$), the NPOR bit is reset to 0 to report the reset condition.

NPOR is set to 1 when [GENSTAT](#) is cleared.

4.4 Charge pump

A dual-stage charge pump supplies the gate drivers for the high-side and low-side MOSFETs. It requires three external capacitors connected between CPC1N and CPC1P, CPC2N and CPC2P, VS and CP.

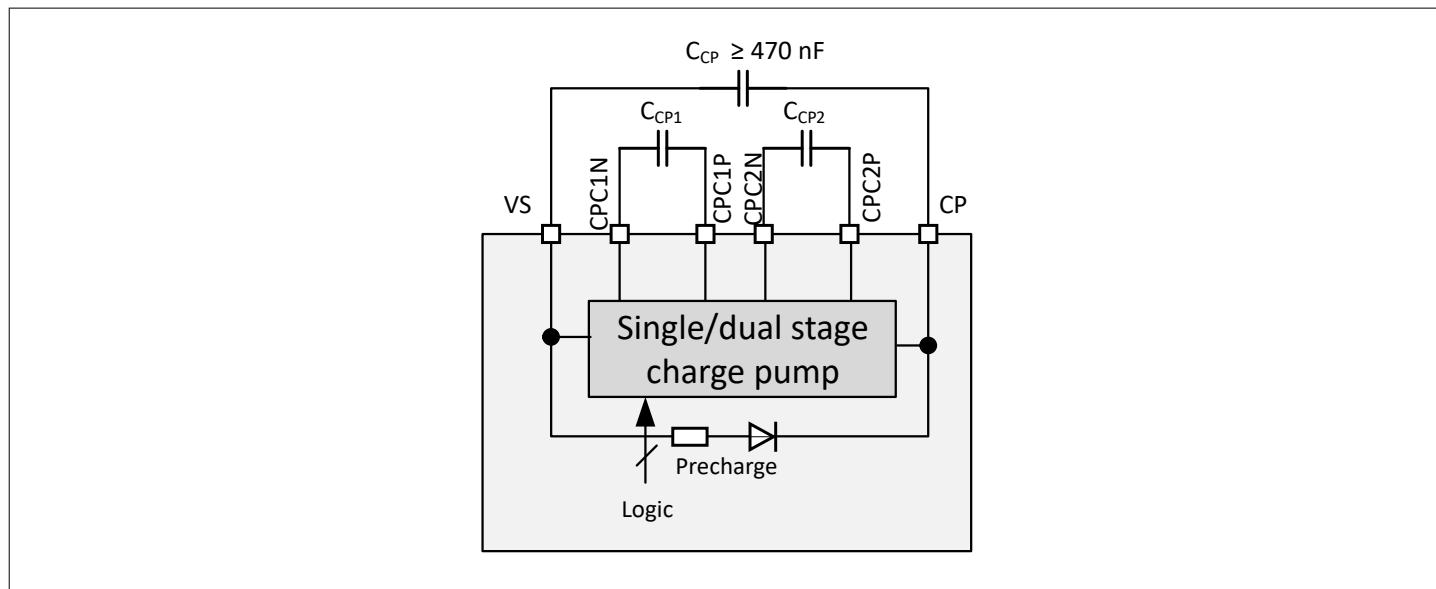

Figure 5 Charge pump

CPSTGA = 0 (default, see [GENCTRL2](#)), the device operates with the dual-stage charge pump.

If CPSTGA = 1 ([GENCTRL2](#)), the device switches automatically to single-stage or dual-stage charge pump automatically:

- If $V_S > V_{CPSO DS}$: the TLE92108-232QX switches from a dual-stage to a single-stage charge pump.
- If $V_S < V_{CPSO SD}$: the TLE92108-232QX switches from single-stage to dual-stage charge pump.

The operation with the single-stage charge pump reduces the current consumption from the VS pin.

4.5 Frequency modulation

A modulation of the charge pump frequency can be activated to reduce the peak emission. The modulation frequency can be selected based on the resolution bandwidth of the peak detector during EMC testing.

The modulation frequency is set by the control bit FMODE in [GENCTRL1](#)

- FMODE = 0: No modulation.
- FMODE = 1: Modulation frequency = 15.6 kHz (default).

4.6 Electrical characteristics

4.6.1 Electrical characteristics: supply

Table 5 Electrical characteristics: supply

VS = 6.0 V to 18 V if VSOVTH = 0, VS = 6.0 V to 28 V if VSOVTH = 1; VDD = 3.0 V to 5.5 V, Tj = -40°C to 150°C, all voltages with respect to ground, positive current flowing into pin (unless otherwise specified)

Parameter	Symbol	Values			Unit	Note or Test Condition	Number
		Min.	Typ.	Max.			
Current consumption, EN = LOW)							
Supply quiescent current	I_{SQ}	-	2	5	μA	$T_j < 85^\circ\text{C}$, $V_S = 13.5\text{ V}$ PASS_MOD=00 _B , PASS_VDS=0 _B	P_5.5.1
Supply quiescent current	I_{SQ2}	-	5	7	μA	$T_j < 85^\circ\text{C}$, $V_S < 25\text{ V}$ PASS_MOD=00 _B , PASS_VDS=0 _B	P_5.5.61
Additional supply quiescent current, brake enabled	I_{SQ_BRAKE}	-	5	7.5	μA	$T_j < 85^\circ\text{C}$, $V_S = 13.5\text{ V}$ ¹⁾ PASS_MOD=01 _B or 10 _B or 11 _B or PASS_VDS=1 _B	P_5.5.60
Logic Supply quiescent current	I_{DD_Q}	-	1	3	μA	$T_j < 85^\circ\text{C}$	P_5.5.3
Total quiescent current	$I_{DD_Q} + I_{SQ}$	-	3	8	μA	$T_j < 85^\circ\text{C}$, $V_S = 13.5\text{ V}$ PASS_MOD=00 _B , PASS_VDS	P_5.5.5
EN Low filter time	t_{DSLEEP}	-	-	Max. tCCP + 3 μs	μs	^{2) 3)} BD_PASS = 0	P_5.5.49
EN Low filter time	t_{ENL_FILT}	1	-	8	μs	²⁾	P_5.5.51
VS for LS1-4 setting	V_{SLEEP_SET}	-	-	5.5	V		P_5.5.63
Current consumption, EN = HIGH							
Supply current	I_{S1}	-	45	55	mA	HBxVDSTH = 001 _B , BD_PASS = 0, $I_{CP} = 0\text{ mA}$	P_5.5.6
Supply current	I_{S2}	-	83	100	mA	$8\text{ V} < V_S < 28\text{ V}$ HBxVDSTH = 001 _B , BD_PASS = 0, $I_{CP} = -12\text{ mA}$, dual stage CP	P_5.5.7

(table continues...)

Table 5 (continued) Electrical characteristics: supply

VS = 6.0 V to 18 V if VSOVTH = 0, VS = 6.0 V to 28 V if VSOVTH = 1; VDD = 3.0 V to 5.5 V, Tj = -40°C to 150°C, all voltages with respect to ground, positive current flowing into pin (unless otherwise specified)

Parameter	Symbol	Values			Unit	Note or Test Condition	Number
		Min.	Typ.	Max.			
Supply current	I_{S3}	–	55	70	mA	18 V < VS < 28 V HBxVDSTH = 001B, BD_PASS = 0, ICP = -12 mA ²⁾ , single stage CP	P_5.5.56
Supply current	I_{S4}	–	55	70	mA	VS = 6 V, HBxVDSTH = 001B, BD_PASS = 0, ICP = -6 mA ²⁾	P_5.5.57
Supply current	$I_{S_BD_PASS}$	–	10	20	mA	HBxMODE=00B, BD_PASS = 1	P_5.5.54
Logic supply current	I_{DD1}	–	3	4	mA	SPI not active, CSA1 and CSA2 off, all IPDDiag off, BD_PASS=0	P_5.5.8
Logic supply current	I_{DD2}	–	3	3.8	mA	⁴⁾ Additional VDD current per CSA on, VCSOx = 4.5 V, LS shunt, CCSO = 1 CSAxL = 0, IPDDiag off	P_5.5.52
Logic supply current	I_{DD3}	–	2	2.8	mA	⁴⁾ Additional VDD current per CSA on, CCSO = 0, VCSOx = 4.5 V, LS shunt, CSAxL = 0, IPDDiag off	P_5.5.55

(table continues...)

Table 5 (continued) Electrical characteristics: supply

VS = 6.0 V to 18 V if VSOVTH = 0, VS = 6.0 V to 28 V if VSOVTH = 1; VDD = 3.0 V to 5.5 V, Tj = -40°C to 150°C, all voltages with respect to ground, positive current flowing into pin (unless otherwise specified)

Parameter	Symbol	Values			Unit	Note or Test Condition	Number
		Min.	Typ.	Max.			
Logic supply current	I_{DD4}	–	6	7	mA	⁵⁾ Additional VDD current per CSA on, VCSOx = 4.5 V, HS shunt, VSOVTH = 1, CSAxL = 1, I_{PDDiag} off	P_5.5.58
Logic supply current	I_{DD5}	–	4.2	5.2	mA	⁵⁾ Additional VDD current per CSA on, VSOVTH = 0, VCSOx = 4.5 V, HS shunt, CSAxL = 1, I_{PDDiag} off	P_5.5.59
Additional logic supply current pull-down	I_{DD_PDDiag}	–	1.5	2	mA	Additional VDD current when all I_{PDDiag} are on	P_5.5.53

VS with active bridge driver (BD_PASS = 0)

UV switch ON voltage	$V_{SUV\ ON}$	–	–	5.5	V	V_S increasing	P_5.5.11
UV switch OFF voltage	$V_{SUV\ OFF}$	4.0	4.5	5.0	V	V_S decreasing	P_5.5.12
UV ON/OFF hysteresis	$V_{SUV\ HY}$	–	0.5	–	V	$V_{SUV\ ON} - V_{SUV\ OFF}$ ²⁾	P_5.5.13
OV switch OFF voltage VSOVTH = 0	$V_{SOV\ OFF1}$	19	–	21	V	V_S increasing	P_5.5.14
OV switch ON voltage VSOVTH = 0	$V_{SOV\ ON1}$	18	–	20	V	V_S decreasing	P_5.5.15
OV switch OFF voltage VSOVTH = 1	$V_{SOV\ OFF2}$	29	–	31	V	V_S increasing	P_5.5.16
OV switch ON voltage VSOVTH = 1	$V_{SOV\ ON2}$	28	–	30	V	V_S decreasing	P_5.5.17
OV ON/OFF hysteresis	$V_{SOV\ HY}$	–	1	–	V	$V_{SUV\ ON} - V_{SUV\ OFF}$ ²⁾	P_5.5.18
VS undervoltage filter time	t_{VSUV_FILT}	7	10	13	μs	¹⁾	P_5.5.47
VS overvoltage filter time	t_{VSOV_FILT}	7	10	13	μs	²⁾	P_5.5.48
CP turn-off delay after VS overvoltage detection	t_{D_CPVSOV}	12.8	16	19.2	μs	²⁾	P_5.5.50

(table continues...)

Table 5 (continued) Electrical characteristics: supply

VS = 6.0 V to 18 V if VSOVTH = 0, VS = 6.0 V to 28 V if VSOVTH = 1; VDD = 3.0 V to 5.5 V, Tj = -40°C to 150°C, all voltages with respect to ground, positive current flowing into pin (unless otherwise specified)

Parameter	Symbol	Values			Unit	Note or Test Condition	Number
		Min.	Typ.	Max.			
VDD							
V _{DD} Power-On-Reset	V _{DD POR}	2.40	2.60	2.80	V	V _{DD} increasing	P_5.5.19
V _{DD} Power-Off-Reset	V _{DD PoffR}	2.30	2.50	2.70	V	V _{DD} decreasing	P_5.5.20
V _{DD} Power-On-Reset Hysteresis	V _{DD POR HY}	–	0.1	–	V	V _{DD POR} - V _{DD PoffR} ²⁾	P_5.5.21

- 1) Additional quiescent current if VS drops below VSLEEP_SET.
- 2) Not subject to production test, specified by design.
- 3) Max. cross-current protection time of the active half-bridges.
- 4) Parameter independent of VSOVTH.
- 5) Parameter independent of CCSO.

4.6.2 Electrical characteristics: logic inputs PWMx, EN

Table 6 Electrical characteristics: PWMx, EN

VS = 6.0 V to 18 V if VSOVTH = 0, VS = 6.0 V to 28 V if VSOVTH = 1; VDD = 3.0 V to 5.5 V, Tj = -40°C to 150°C, all voltages with respect to ground, positive current flowing into pin (unless otherwise specified)

Parameter	Symbol	Values			Unit	Note or Test Condition	Number
		Min.	Typ.	Max.			
EN high voltage	V _{ENH}	0.7 × V _{DD}	–	–	V	–	P_5.5.22
EN low voltage	V _{ENL}	–	–	0.3 × V _{DD}	V	–	P_5.5.23
EN hysteresis	V _{ENHY}	–	0.12 × V _{DD}	–	V	1)	P_5.5.24
EN pull-down resistor	R _{PD_EN}	30	40	50	kΩ	–	P_5.5.25
PWMx high voltage	V _{PWMH}	0.7 × V _{DD}	–	–	V	–	P_5.5.26
PWMx low voltage	V _{PWML}	–	–	0.3 × V _{DD}	V	–	P_5.5.27
PWMx hysteresis	V _{PWMHY}	–	0.12 × V _{DD}	–	V	1)	P_5.5.28
PWMx pull-down resistor	R _{PD_PWMx}	30	40	50	kΩ	–	P_5.5.29

- 1) Not subject to production test, specified by design.

4.6.3 Electrical characteristics charge pump

Table 7 Electrical characteristics: charge pump

$V_S = 6.0\text{ V}$ to 18 V if $V_{SOVTH} = 0$, $V_S = 6.0\text{ V}$ to 28 V if $V_{SOVTH} = 1$; $V_{DD} = 3.0\text{ V}$ to 5.5 V , $T_j = -40^\circ\text{C}$ to 150°C , all voltages with respect to ground, positive current flowing into pin (unless otherwise specified)

Parameter	Symbol	Values			Unit	Note or Test Condition	Number
		Min.	Typ.	Max.			
Charge Pump Frequency	f_{CP}	–	250	–	kHz	³⁾	P_5.5.30
Output Voltage VCP vs. VS	V_{CPmin}	8.5	–	–	V	$V_S = 6\text{ V}$, $I_{CP} = -6\text{ mA}$	P_5.5.31
Regulated output voltage VCP vs. VS, CPSTGA = 0	V_{CP1}	11	15	17	V	$8\text{ V} < V_S < 28\text{ V}$, $I_{CP} = -12\text{ mA}$	P_5.5.32
Regulated output voltage VCP vs. VS, CPSTGA = 1	V_{CP2}	12	15	17	V	$18\text{ V} < V_S < 28\text{ V}$, $I_{CP} = -12\text{ mA}$	P_5.5.41
Turn-on time, CPSTGA = 0	t_{ON_VCP1}	10	40	80	μs	$8\text{ V} < V_S < 28\text{ V}$ (25%) ^{1) 2) 3) 4)}	P_5.5.34
Rise time, CPSTGA = 0	t_{RISE_VCP1}	10	60	100	μs	$8\text{ V} < V_S < 28\text{ V}$ (25%-75%) ^{1) 2) 3) 4)}	P_5.5.35
Turn-on time, CPSTGA = 1	t_{ON_VCP2}	10	40	80	μs	$18\text{ V} < V_S < 28\text{ V}$ (25%) ^{1) 2) 3) 5)}	P_5.5.36
Rise time, CPSTGA = 1	t_{RISE_VCP2}	10	60	100	μs	$18\text{ V} < V_S < 28\text{ V}$ (25%-75%) ^{1) 2) 3) 5)}	P_5.5.37
Charge Pump Undervoltage (referred to VS)	V_{CPUV1}	5.5	6	6.5	V	$CPUVTH = 0$, VCP falling	P_5.5.38
Charge Pump Undervoltage (referred to VS)	V_{CPUV2}	7	7.5	8	V	$CPUVTH = 1$, VCP falling	P_5.5.42
Automatic switch over dual to single stage charge pump	$V_{CPSO DS}$	16	17	18	V	$CPSTGA = 1$	P_5.5.43
Automatic switch over single to dual stage charge pump	$V_{CPSO SD}$	15.5	16.5	17.5	V	$CPSTGA = 1$	P_5.5.44
Charge pump switch over hysteresis	$V_{CPSO HY}$	–	0.5	–	V	³⁾ $CPSTGA = 1$, $V_{CPSO DS} - V_{CPSO SD}$	P_5.5.45
Charge Pump Undervoltage Filter Time	t_{CPUV}	51	64	77	μs	³⁾	P_5.5.39
Charge pump minimum output current	I_{CPOC1}	–	–	-12	mA	^{2) 3) 4)} $V_S = 13.5\text{ V}$; $CPSTGA = 0$	
Charge pump minimum output current	I_{CPOC2}	–	–	-12	mA	^{2) 3) 5)} $V_S = 18\text{ V}$; $CPSTGA = 1$	

- 1) Parameter dependent on the capacitance C_{CP} .
- 2) $C_{CPC1} = C_{CPC2} = 220\text{ nF}$, $C_{CP} = 470\text{ nF}$, $I_{CP} = 0\text{ mA}$.
- 3) Not subject to production test, specified by design.
- 4) Dual stage charge pump.
- 5) Single stage charge pump.

5 Floating gate drivers

The TLE92108-232QX integrates sixteen floating gate drivers capable of controlling a wide range of n-channel MOSFETs. They are configured as eight high-sides and low-sides, building eight half-bridges.

This section describes the MOSFET control by the gate drivers.

After power-on reset, the bridge driver is in passive mode (default value of `BD_PASS` = 1 and all `HBxMODE`=00_B). Refer to [Chapter 5.4](#) and [Chapter 5.5](#).

The bridge driver is in active mode by setting `BD_PASS` to 0. [Chapter 5.1](#), [Chapter 5.2](#) and [Chapter 5.3](#) describes the static and PWM control in active mode.

Attention: *It is highly recommended to have all `HBxMODE` bits set to 00_B or 11_B before setting `BD_PASS` to 0 in order to avoid wrong drain-source overvoltage detection.*

Table 8 Operating modes of the gate driver

EN	BD_PASS	HBxMODE[1:0]	Gate driver	Comment	Chapter
High	0	x	Active ¹⁾		Chapter 5.1 Chapter 5.2 Chapter 5.3
High	1	One HBxMODE = 01 _B or 10 _B	Active ¹⁾	Equivalent to EN=High and <code>BD_PASS</code> = 0	Chapter 5.1 Chapter 5.2 Chapter 5.3
High	1	All HBxMODE=00 _B or 11 _B	Passive		Chapter 5.5
Low	x	x	Passive		Chapter 5.5

¹⁾ Provided that no VS overvoltage, VS undervoltage, CP undervoltage or overtemperature failure are detected, and TLE92108-232QX is not in Fail Safe Mode.

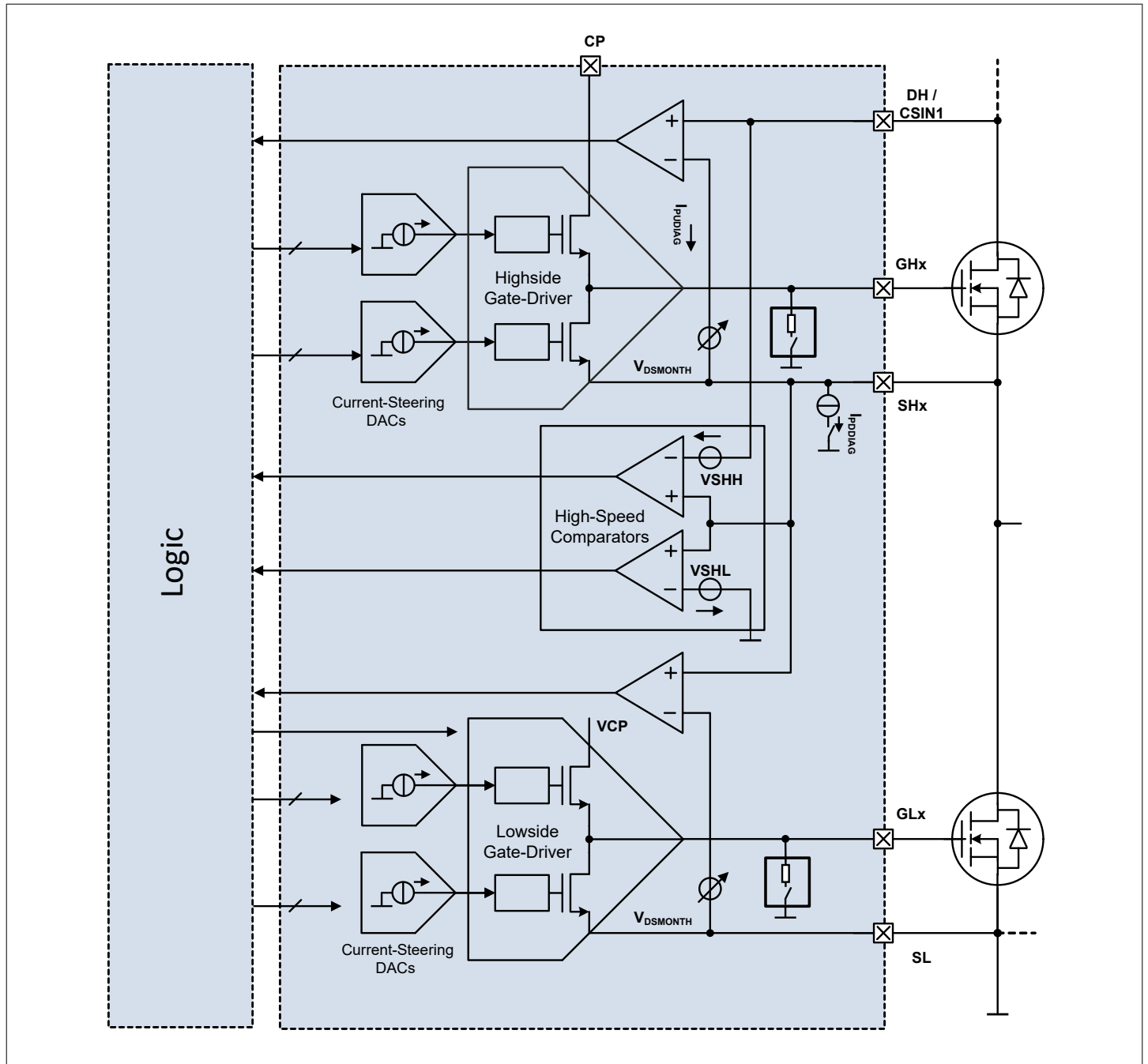

Figure 6 Block diagram - Gate driver for one half-bridge

5.1 MOSFET control with bridge driver in active mode ($BD_PASS = 0$ and $EN = High$)

Depending on the configuration bits $HBxMODE[1:0]$ ([HBMODE](#), [Table 9](#) and [Table 11](#)), each high-side and low-side MOSFETs can be:

- deactivated
- activated (statically, no PWM)
- activated in PWM mode ([Chapter 5.3](#), [PWMSET](#))

Table 9 Half-bridge mode selection

$HBxMODE[1:0]$ ¹⁾	Configuration of HSx/LSx ¹⁾
00 _B	LSx and HSx MOSFETs are actively kept OFF (default)
01 _B	LSx MOSFET is ON (static or PWM, refer to Table 11), HSx MOSFET is actively kept OFF
10 _B	HSx MOSFET is ON (static or PWM, refer to Table 11), LSx MOSFET is actively kept OFF
11 _B	Reserved - LSx and HSx MOSFETs are actively kept OFF

1) x = 1 ... 8.

5.2 Static activation with bridge driver in active mode ($BD_PASS = 0$)

In this section, we consider the static activation of the high-side and low-side MOSFET of the half-bridge x, x = 1...8. Refer to [Table 11](#) for the setting of a high-side or low-side in the static or PWM operation.

If HBx is not mapped to any activated PWM channel, the low-side or high-side MOSFET of HBx is statically activated (no PWM) by setting $HBxMODE[1:0]$ to respectively (0,1) or (1,0).

The configured cross-current protection and the Drain-Source overvoltage blank times for the Half-Bridge x are noted $t_{HBxCCP Active}$ and $t_{HBxBLANK Active}$ (refer to [Chapter 6.5](#)).

The charge and discharge currents applied to the static controlled Half-Bridge x are noted $ICHGSTx$ ([ST_ICHG](#)).

$I_{HARDOFF}$ is the maximum current that the gate drivers can sink. It corresponds to the discharge current when $IDCHGx[4:0] = 31_D$ (See [PWM_IDCHG_ACT](#)). This current is used to keep a MOSFET off, when the opposite MOSFET of the same half-bridge is being turned on. This feature avoids parasitic cross-current conduction.

$ICHGSTx$ is the current sourced, respectively sunk, by the gate driver to turn-on the high-side x or low-side x. $ICHGSTx$ is configured in the control register [ST_ICHG](#).

Table 10 Static charge and discharge currents

$ICHGSTx[3:0]$ ¹⁾	Nom. charge current [mA] ²⁾	Nom. discharge current [mA] ³⁾	Max. deviation to typ. values
0000 _B	1.0	1.0	+/- 60%
0001 _B	2.0	2.8	+/- 60 %
0010 _B	4.5	5.7	+/- 60 %
0011 _B	8.0	9.4	+/- 38 %
0100 _B	12.5	14.2	+/- 38 %
0101 _B	17.8	19.7	+/- 38 %
0110 _B	23.9	26.0	+/- 38 %
0111 _B	30.0	32.0	+/- 28 %

(table continues...)

Table 10 (continued) Static charge and discharge currents

ICHGSTx[3:0] ¹⁾	Nom. charge current [mA] ²⁾	Nom. discharge current [mA] ³⁾	Max. deviation to typ. values
1000 _B	37.1	39.5	+/- 28 %
1001 _B	44.3	46.8	+/- 28 %
1010 _B	52.3	54.7	+/- 28 %
1011 _B	60.2	62.5	+/- 28 %
1100 _B	68.3	70.6	+/- 28 %
1101 _B	76.8	78.5	+/- 28 %
1110 _B	86.0	87.0	+/- 28 %
1111 _B	96.0	95.0	+/- 25 %

1) Refer to [ST_ICHG](#)

2) $V_S \geq 8V$ and $V_{GS} \leq V_{GS(ON)1}$ if ICHGSTx $\leq 7_D$, $V_S \geq 8V$ and $V_{GS} \leq V_{GS(ON)2}$ if ICHGSTx $\geq 8_D$

3) $V_{GS} \geq V_{GS(OFF)1}$ if ICHGSTx $\leq 7_D$, $V_{GS} \geq V_{GS(OFF)2}$ if ICHGSTx $\geq 8_D$

IHOLD is the hold current used to keep the gate of the external MOSFETs in the desired state. This parameter is configurable with the [IHOLD](#) control bit in [GENCTRL2](#).

If [IHOLD](#) = 0:

- the MOSFETs are kept ON with the current I_{CHG8} (12.5 mA typ.)
- the MOSFETs are kept OFF with the current I_{DCHG8} (14.2 mA typ.)

If [IHOLD](#) = 1:

- the MOSFETs are kept ON with the current I_{CHG12} (23.9 mA typ.)
- the MOSFETs are kept with the current I_{DCHG12} (26.0 mA typ.)

The static discharge current is applied to turn off the MOSFETs when the bridge driver is in active mode when the following failures occur:

- V_S undervoltage/overvoltage
- Overtemperature
- V_{DS} overvoltage
- Charge pump undervoltage
- Overcurrent if [OCEN](#) = 1

5.2.1 Static activation of a high-side MOSFET

Turn-on with cross-current protection

If LSx is ON ([HBxMODE](#)[1:0] = 01_B), before the activation of HSx ([HBxMODE](#)[1:0] = 10_B) then the high-side MOSFET is turned on after a cross-current protection time (refer to [Figure 7](#)):

- after the CSN rising edge and for the duration $t_{HBxCCP Active}$:
 - the high-side MOSFET is kept OFF with the current -ICHGSTx
 - the gate of the low-side MOSFET is discharged with the current -ICHGSTx

5 Floating gate drivers

- at the end of $t_{HBxCCP \text{ Active}}$ and for the duration $t_{HBxBLANK \text{ Active}} + t_{FVDS}$:
 - the gate of the high-side MOSFET is charged with the current $ICHGSTx$
 - low-side MOSFET is kept OFF with the current $-IHARDOFF$ (hard off phase)
- at the end of t_{FVDS} :
 - the drive current of the high-side MOSFET is reduced to $IHOLD$
 - the drive current of the low-side MOSFET is set to $-IHOLD$

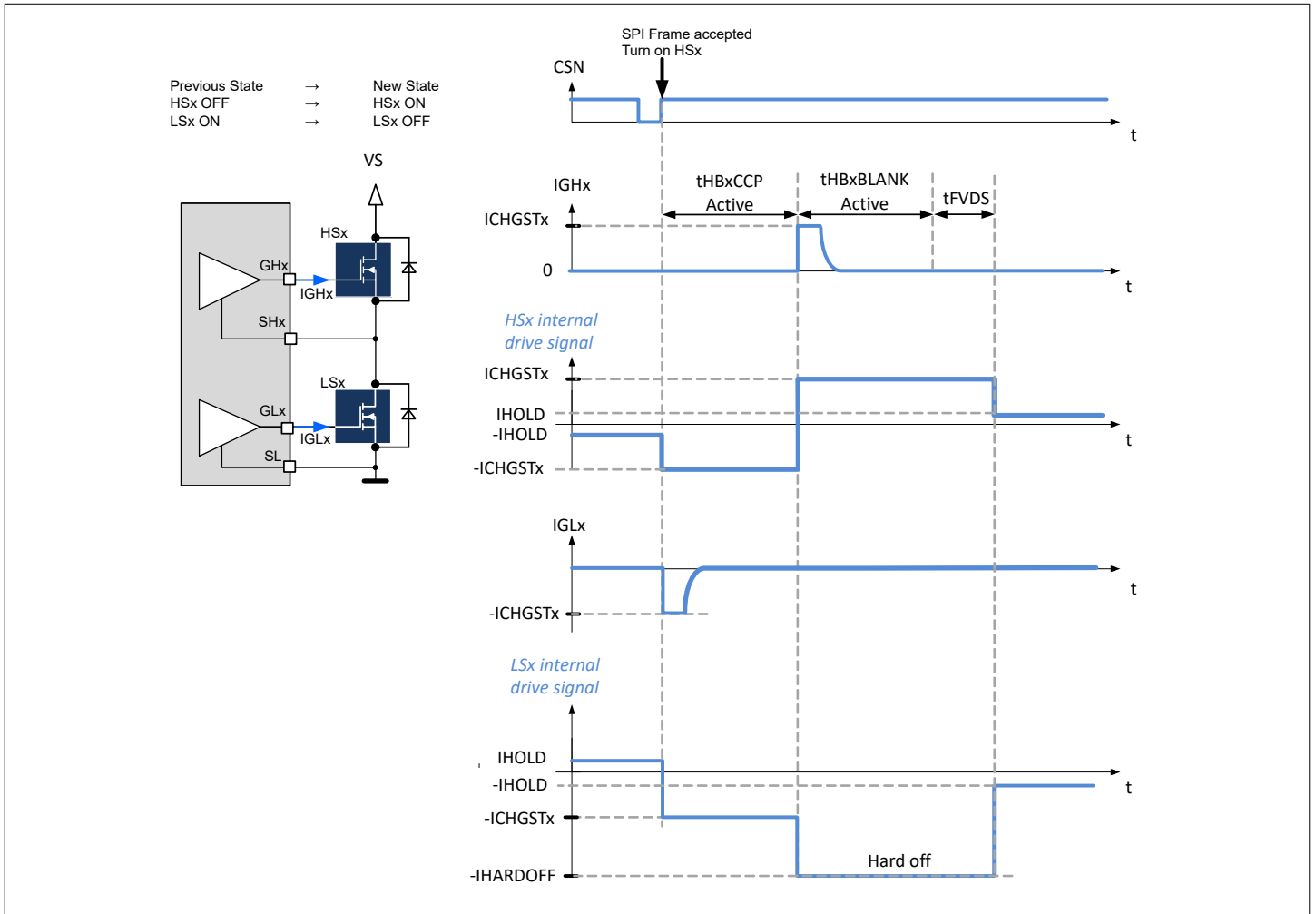

Figure 7 Turn-on of a high-side MOSFET with cross-current protection

Note: The CSN rising edge must be synchronized with the device logic. Therefore SPI commands are executed with a delay of up to $3 \mu s$ after the CSN rising edge.

Turn-on without cross-current protection

If LSx is OFF ($HBxMODE[1:0] = 00_B$), before the activation of HSx ($HBxMODE[1:0] = 10_B$), then the high-side MOSFET is turned on without cross-current protection (refer to [Figure 8](#)):

- after the CSN rising edge and for a duration $t_{HBxBLANK \text{ Active}} + t_{FVDS}$:
 - the gate of the high-side MOSFET is charged with the current $ICHGSTx$
 - the low-side MOSFET is kept OFF with the current $-IHARDOFF$
- at the end of t_{FVDS} :
 - the drive current of the high-side MOSFET is reduced to $IHOLD$
 - the drive current of the low-side MOSFET is set to $-IHOLD$

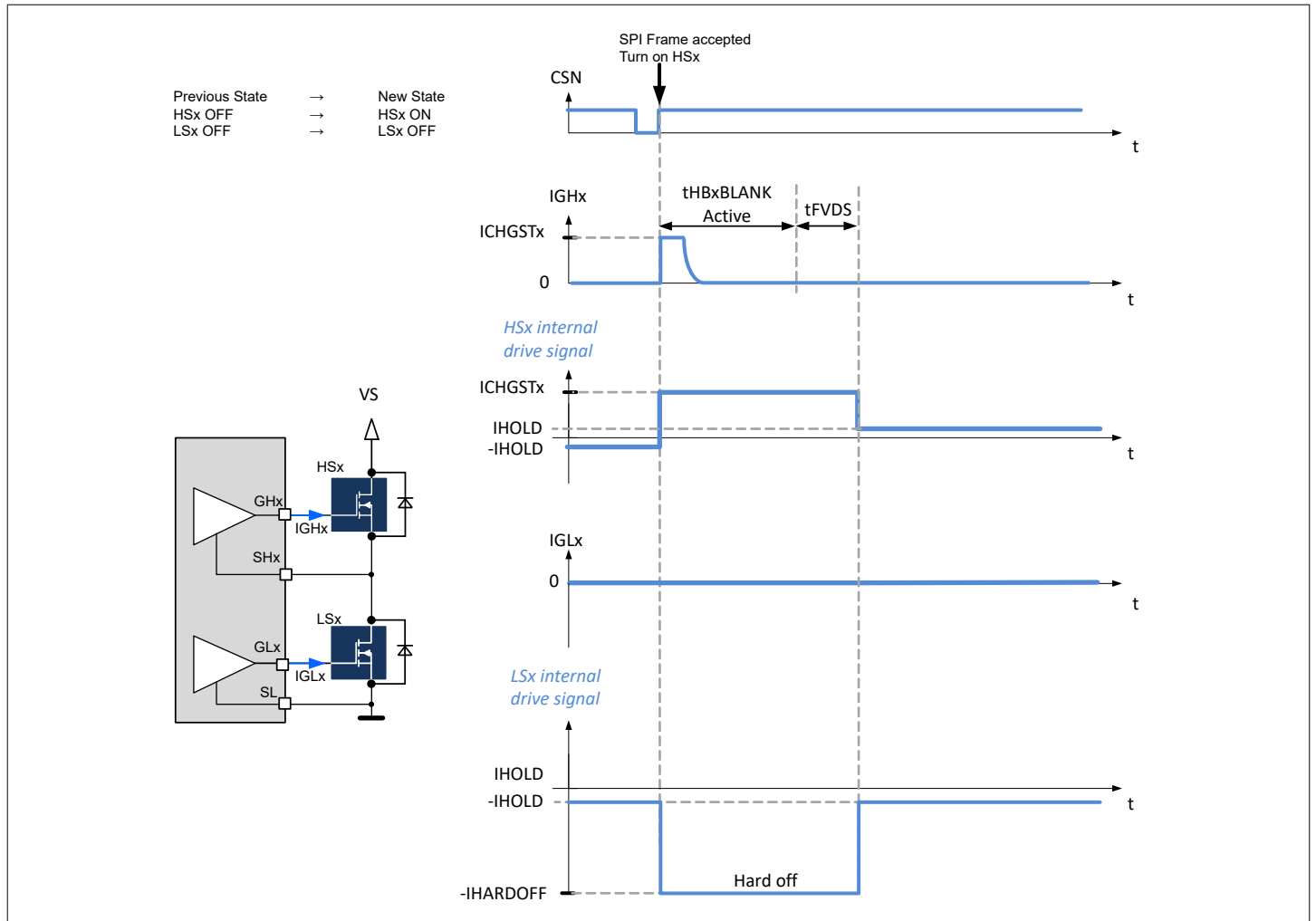

Figure 8 Turn-on of a high-side MOSFET without cross-current protection

Note: The CSN rising edge must be synchronized with the device logic. Therefore SPI commands are executed with a delay of up to 3 μ s after the CSN rising edge.

5.2.2 Static activation of a low-side MOSFET

The description of the static activation of a low-side x differs from the description of [Chapter 5.2.1](#) only by exchanging high-side x and low-side x.

5.2.3 Turn-off of the high-side and low-side MOSFETs of a half-bridge

When the TLE92108-232QX receives a SPI to turn-off both the high-side and low-side MOSFETs of the half-bridge x ($HBxMODE[1:0] = (0,0)$ or $(1,1)$):

- the gate of HSx and LSx are discharged with the current $-ICHGSTx$ for the duration $t_{HBxCCP Active}$ ([Figure 9](#))
- at the end of $t_{HBxCCP Active}$, the drive current of HSx and LSx are reduced to $-IHOLD$

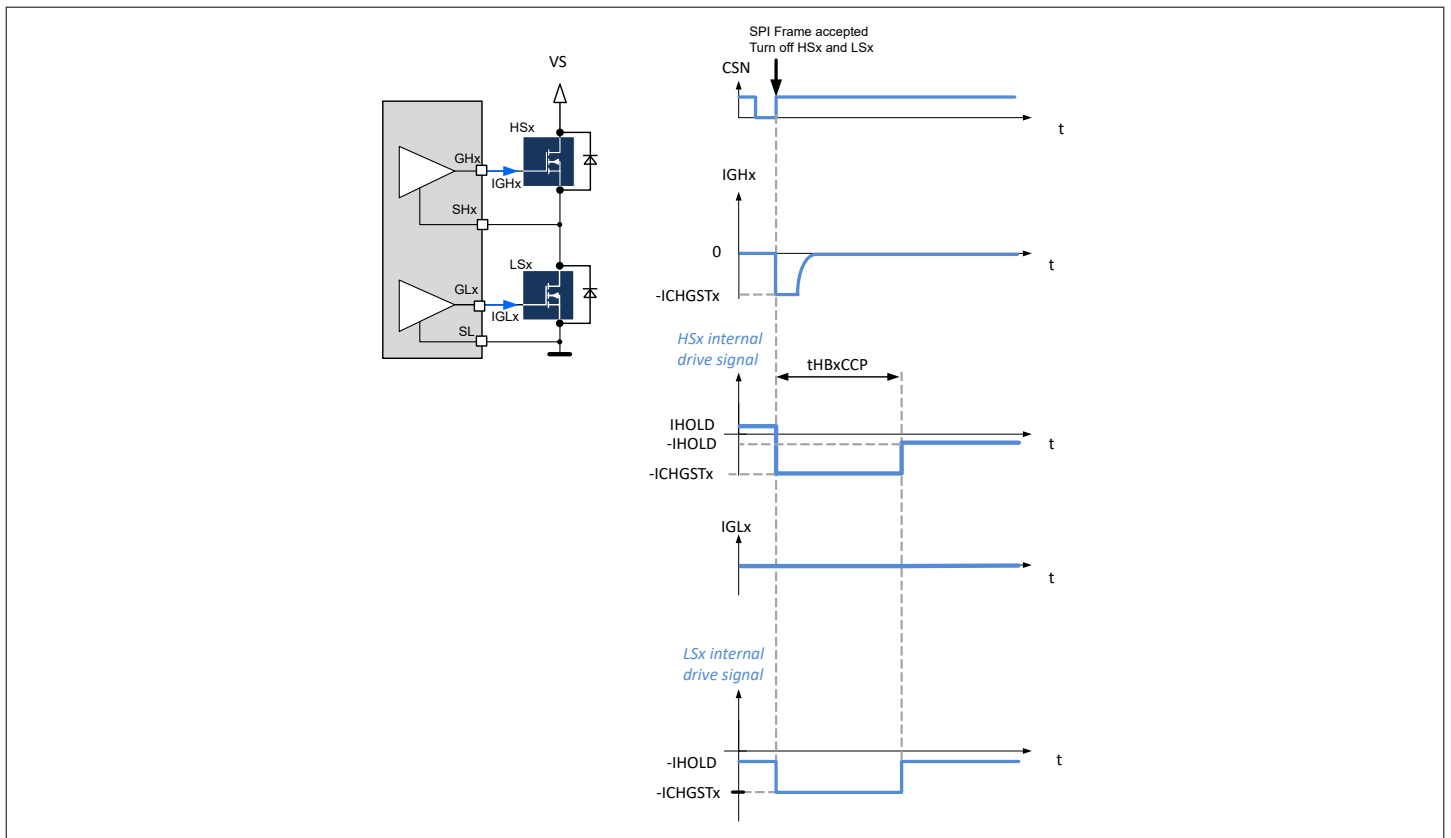

Figure 9 Turn-off of the high-side and low-side MOSFETs of a half-bridge

Note: The CSN rising edge must be synchronized with the device logic. Therefore SPI commands are executed with a delay of up to $3 \mu s$ after the CSN rising edge.

5.3 PWM operation with bridge driver in active mode (BD_PASS = 0)

The TLE92108-232QX integrates three PWM channels. The pins PWM1, PWM2 and PWM3 provide the PWM signal for each PWM channel.

One half-bridge can be mapped to one of the PWM channels according to the settings of the control registers **HBMODE** and **PWMSET** (see [Table 11](#)):

- PWMxEN in **PWMSET**, enables or disables the PWM channel x
- The control bits PWMx_HB[2:0] in **PWMSET** select the half-bridge
- The control bits HBMODE[1:0] (**HBMODE**) of the half-bridge selected by PWMx_HB[2:0] configures the low-side or the high-side MOSFET in PWM mode

Example: the following bits must be set to map the low-side of HB3 to the PWM channel 2 (start sequence with PWM):

1. Set HB3MODE[1:0] to (0,0): HB3 is in high impedance
2. Set PWM2_HB[2:0] to (0,1,0) and set PWM2EN to 1 (HB3 stays in high impedance, independently from the signal present at the PWM2 pin)
3. Set HB3MODE[1:0] to (0,1): PWM2 is applied to the low-side of HB3

Table 11 PWM channel settings

PWMxEN ¹⁾	PWMx_HB[2:0] ¹⁾	HByMODE[1:0] ²⁾	PWMx channel setting ¹⁾
0 _B	don't care	don't care	no PWM operation
don't care	don't care	00 _B	no PWM operation on the selected HB
don't care	don't care	11 _B	no PWM operation on the selection HB
1 _B	000 _B	01 _B	Low-side of HB1 is mapped to PWMx
1 _B	001 _B	01 _B	Low-side of HB2 is mapped to PWMx
1 _B	010 _B	01 _B	Low-side of HB3 is mapped to PWMx
1 _B	011 _B	01 _B	Low-side of HB4 is mapped to PWMx
1 _B	100 _B	01 _B	Low-side of HB5 is mapped to PWMx
1 _B	101 _B	01 _B	Low-side of HB6 is mapped to PWMx
1 _B	110 _B	01 _B	Low-side of HB7 is mapped to PWMx
1 _B	111 _B	01 _B	Low-side of HB8 is mapped to PWMx
1 _B	000 _B	10 _B	High-side of HB1 is mapped to PWMx
1 _B	001 _B	10 _B	High-side of HB2 is mapped to PWMx
1 _B	010 _B	10 _B	High-side of HB3 is mapped to PWMx
1 _B	011 _B	10 _B	High-side of HB4 is mapped to PWMx
1 _B	100 _B	10 _B	High-side of HB5 is mapped to PWMx
1 _B	101 _B	10 _B	High-side of HB6 is mapped to PWMx
1 _B	110 _B	10 _B	High-side of HB7 is mapped to PWMx
1 _B	111 _B	10 _B	High-side of HB8 is mapped to PWMx

1) x = 1...3

2) the half-bridge y is selected by the PWMx_HB[2:0] bits

Note: An SPI error is reported if one half-bridge is mapped to several activated PWM channels. In this case the external MOSFETs of the impacted half-bridge are turned-off and the corresponding status bit (HBxPWME) of the HBVOUT_PWMERR register is set.

5.3.1 Determination of the active and free-wheeling MOSFET

An active free-wheeling is automatically implemented when a half-bridge is activated in PWM mode to reduce the power dissipation of the free-wheeling (FW) MOSFET: If the active MOSFET is OFF, the opposite (free-wheeling) MOSFET of the same half-bridge is actively turned on. See Figure 11, Figure 12, Figure 13, Figure 14, .

If EN_GEN_CHECK = 0: the PWM MOSFET is considered as the active MOSFET and the opposite MOSFET of the same half-bridge is considered as the free-wheeling MOSFET.

If EN_GEN_CHECK = 1: At the end of the cross-current protection times (tHBxCCP Active, tHBxCCP FW) of each MOSFET (both MOSFETs are supposed to be off) the device detects which MOSFET of the half-bridge is the active MOSFET and which MOSFET is the FW MOSFET (Figure 10).

- If $V_{SHx} > V_{SHH}$: The high-side MOSFET is the FW MOSFET and the low-side MOSFET is the active MOSFET
- If $V_{SHx} < V_{SHL}$: Then the low-side MOSFET is the FW MOSFET and the high-side MOSFET is the active MOSFET
- If $V_{SHL} < V_{SHx} < V_{SHH}$: No clear distinction between the FW MOSFET and the active MOSFET. The MOSFET to be turned on is considered as the active MOSFET.

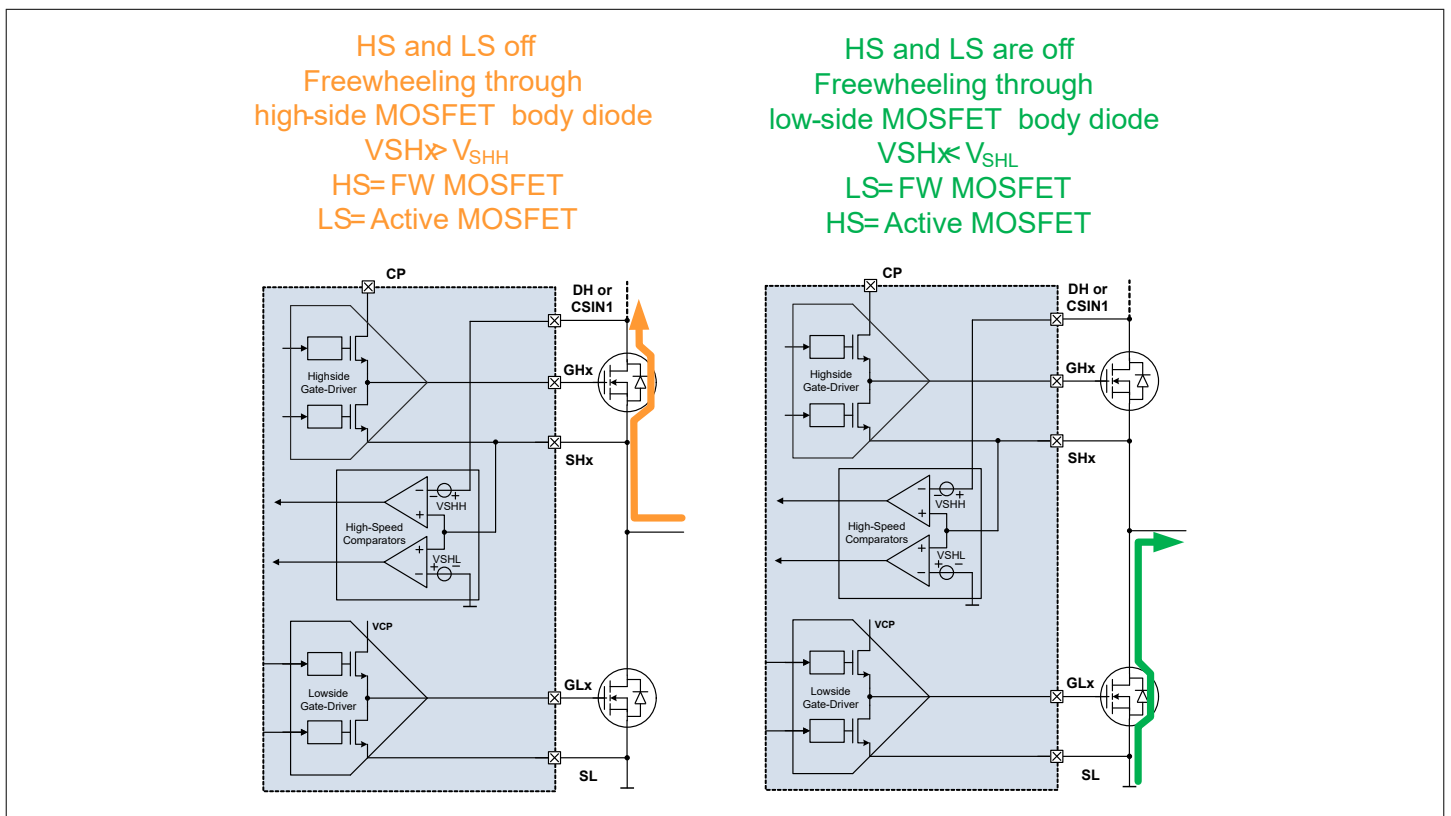

Figure 10 Detection principle of the active and freewheeling MOSFET

Note: The PWM signal is applied to the MOSFET selected by HBxMODE[1:0], independently from the free-wheeling and the active MOSFET.

Note: It is not possible to determine the active or FW MOSFET if the PWM on-time is shorter than $t_{HBxCCP\ FW}$, or if the PWM-off-time is shorter than $t_{HBxCCP\ Active}$ (Refer to Chapter 5.3.5). In this case, the PWM MOSFET is considered as the active MOSFET. In other words, it is assumed that the motor operates as load.

Figure 11, Figure 12 show examples of free-wheeling and active MOSFET when the motor operates as load.

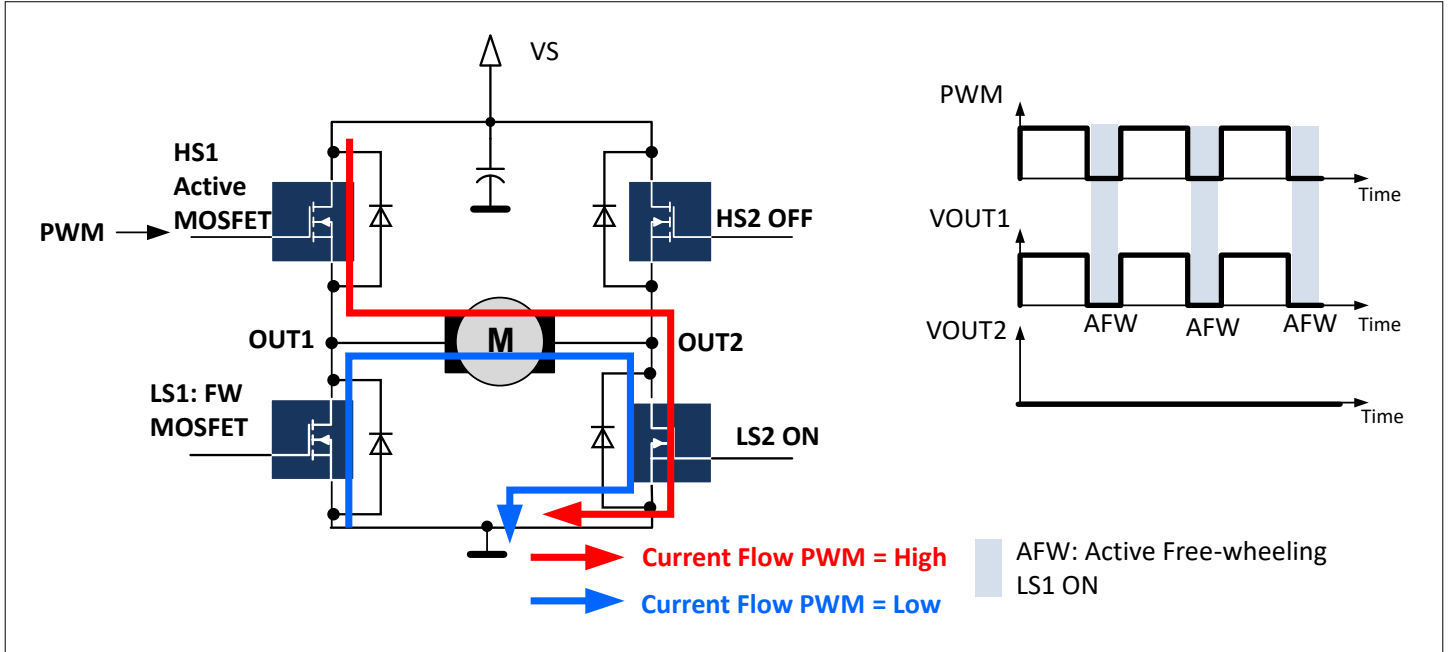

Figure 11 Active freewheeling on HB1: PWM1EN = 1. PWM applied to HS1 (HB1MODE[1:0] = 10_B). The motor operates as load: HS1 is the active MOSFET, LS1 is the FW MOSFET.

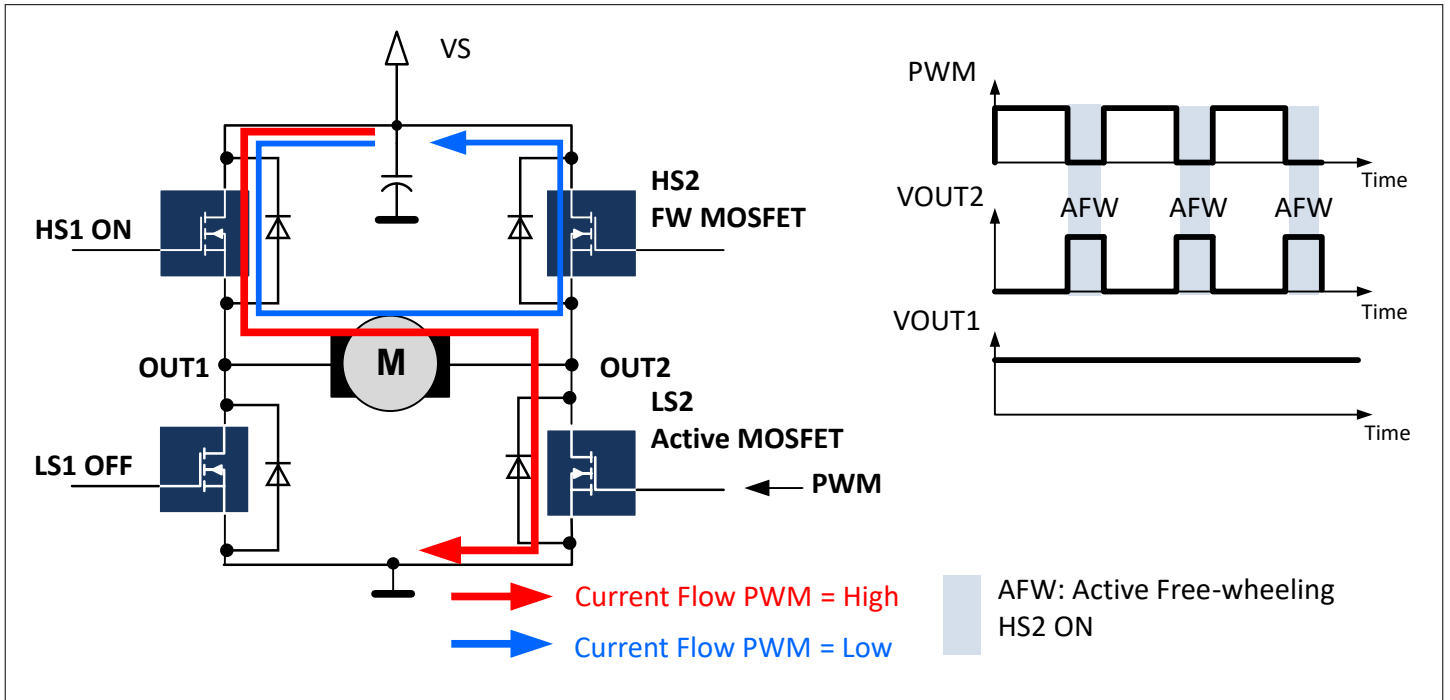

Figure 12 Active freewheeling on HB2: PWM1EN = 1. PWM applied to LS2 (HB2MODE[1:0] = 01_B). The motor operates as load: LS2 is the active MOSFET, HS2 is the FW MOSFET.

Figure 13 and Figure 14 show examples of free-wheeling and active MOSFET when the motor operates as generator.

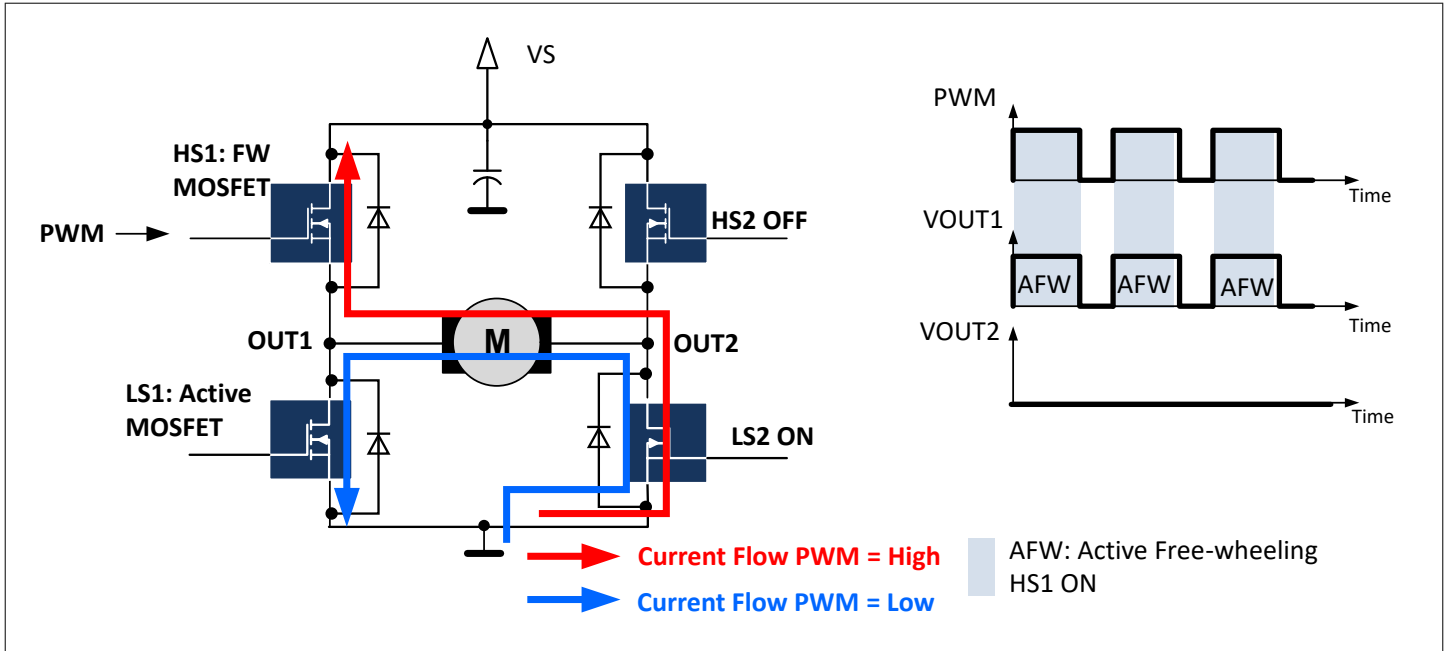

Figure 13 Active freewheeling on HB1: $PWM1EN = 1$. PWM applied to $HS1$ ($HB1MODE[1:0] = 10_B$). The motor operates as generator: $LS1$ is the active MOSFET, $HS1$ is the FW MOSFET.

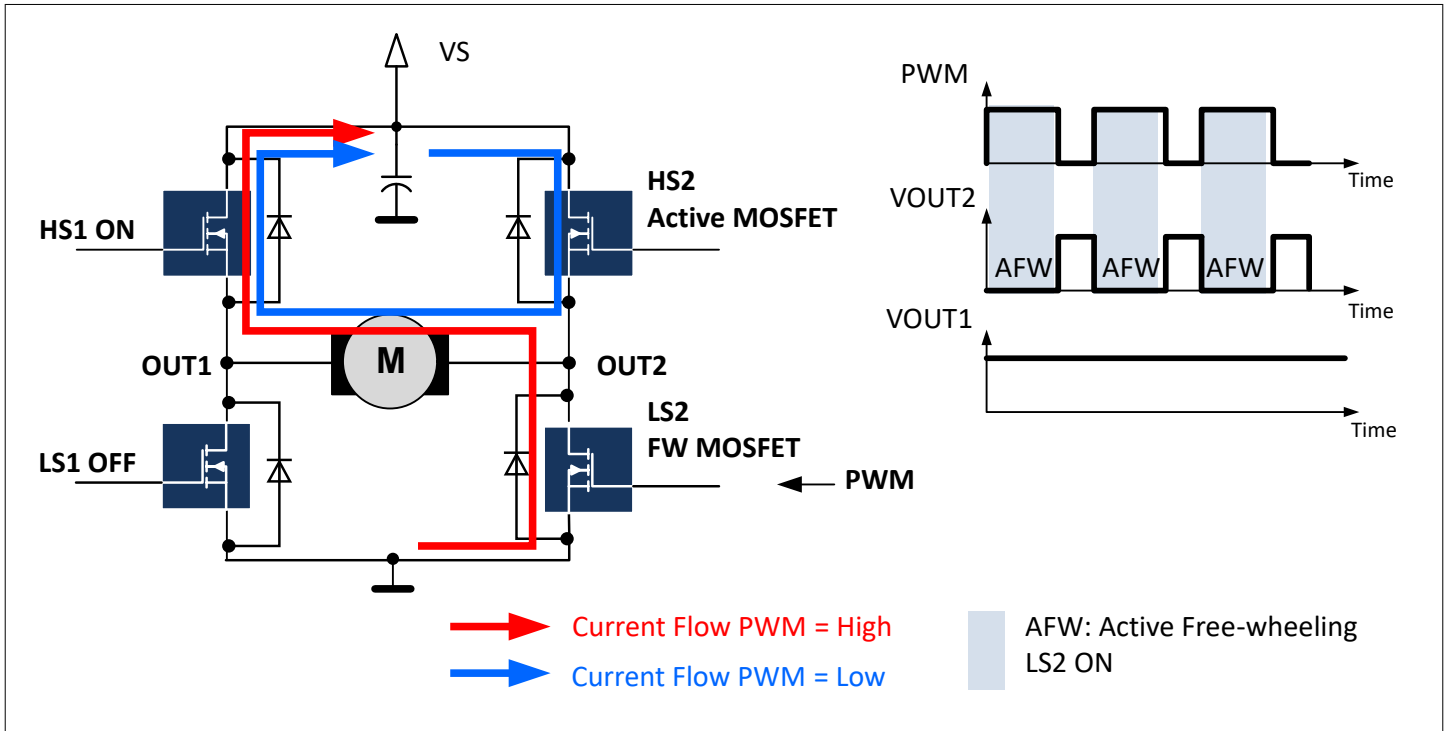

Figure 14 Active freewheeling on HB2: $PWM1EN = 1$. PWM applied to $LS2$ ($HB2MODE[1:0] = 01_B$). The motor operates as generator: $HS2$ is the active MOSFET, $LS2$ is the FW MOSFET.

5.3.2 Configuration in PWM mode

The following sections describe the different control schemes in PWM mode. They differ during the pre-charge and pre-discharge phases (Figure 15):

- Adaptive gate control (AGC[1:0] = (1,0) or (1,1), [GENCTRL2](#)): in this mode a pre-charge current and a pre-discharge current are applied to the gate of the PWM MOSFET. These currents are used to regulate the effective turn-on and turn-off delays to the respective target values. Refer to [Chapter 5.3.3](#).
- No adaptive gate control (AGC[1;0] = (0,0)): in this mode, the pre-charge and pre-discharge phases are deactivated. Refer to [Chapter 5.3.4.1](#).
- No adaptive gate control (AGC[1;0] = (0,1)). In this mode:
 - the pre-charge phase is deactivated
 - during the pre-discharge phase, the gate of the PWM MOSFET mapped to the PWM channel x, x = 1...3, is discharged with the configured current IPCHGINIT (Refer to [PWM_PCHG_INIT](#) and [Chapter 5.3.4.2](#))

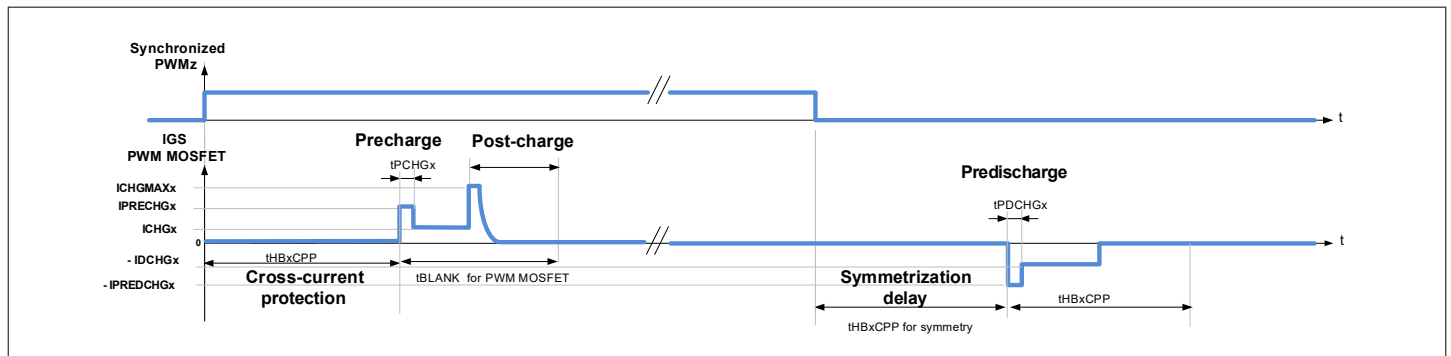

Figure 15 PWM overview showing pre-charge, pre-discharge and post charge phases, AGC[1:0] = 10_B or 11_B, POCHGDIS = 1_B.

5.3.3 PWM operation with adaptive gate control

This section describes the MOSFETs control during high-side or low-side PWM operation when the adaptive gate control is enabled ($AGC[1:0] = (1,0)$ or $(1,1)$, [GENCTRL2](#)).

Refer to [Chapter 5.3.1](#) for the definition of the active and of the freewheeling MOSFET according to the setting of [AGC](#).

Assumption: a high-side or low-side MOSFET driver is mapped to the PWM channel z , $z = 1,2$ or 3 .

Refer to [Figure 16](#) for high-side PWM and [Figure 19](#) for low-side PWM for the description of the switching phase.

The TLE92108-232QX adapts the pre-charge current, respectively the pre-discharge current, in order to match the effective turn-on delay (t_{DON}) and turn-off delay (t_{DOFF}) to the configured values.

The configured turn-on and turn-off delays of the respective PWM MOSFETs are set by the registers [TDON_OFF1](#), [TDON_OFF2](#), [TDON_OFF3](#).

The effective turn-on and turn-off delays of the respective active MOSFETs are read out from the status registers [EFF_TDON_OFF1](#), [EFF_TDON_OFF2](#), [EFF_TDON_OFF3](#).

Table 12 Abbreviations for adaptive turn-on and turn-off phases in PWM configuration

Abbreviation	Definition
Suffix x	Related to the half-bridge x ($x = 1 \dots 8$)
Suffix z	Related to the PWM channel z ($z = 1,2$ or 3)
VGS_HSx	Gate-Source voltage of high-side MOSFET x
IGS_HSx	Gate current of high-side MOSFET x IGS_HSx is positive when the current flows out of GHx.
VGS_LSx	Gate-Source voltage of low-side MOSFET x
IGS_LSx	Gate current of low-side MOSFET x IGS_LSx is positive when the current flows out of GLx.
tHBxCCP ACTIVE	Active cross-current protection time of HBx. See control registers CCP_BLK1 , CCP_BLK2_ACT , PWM_ICHGMAX_CCP_BLK3_ACT and Chapter 6.5 .
tHBxBLANK ACTIVE	Active Drain-source overvoltage blank time of HBx. See control registers CCP_BLK1 , CCP_BLK2_ACT , PWM_ICHGMAX_CCP_BLK3_ACT and Chapter 6.5 .
tHBxCCP FW	Freewheeling cross-current protection time of HBx. See control registers CCP_BLK1 , CCP_BLK2_FW , PWM_ICHGMAX_CCP_BLK3_FW and Chapter 6.5
tHBxBLANK FW	Freewheeling drain-source overvoltage blank time of HBx. See control registers CCP_BLK1 , CCP_BLK2_FW , PWM_ICHGMAX_CCP_BLK3_FW and Chapter 6.5
PWMz	External PWM signal applied to the input pin PWMz.
ICHGMAXz	Maximum drive current of the half-bridge mapped to PWM channel z during the pre-charge and pre-discharge phases. See control registers PWM_ICHGMAX_CCP_BLK3_ACT and PWM_ICHGMAX_CCP_BLK3_FW ICHGMAXz is also the drive current for the post-charge phase IPRECHGz and IPREDCHGz are limited to ICHGMAXz.
IPRECHGz	Pre-charge current sourced by the gate driver mapped to the PWM channel z during tPCHGz. Internal and self-adaptive parameter (if $AGC = (1,0)$ or $(1,1)$, GENCTRL2) IPRECHGz is clamped between I_{CHG0} and ICHGMAXz.
IPCHGINITz	Initial value of IPRECHGz. Refer to PWM_PCHG_INIT

(table continues...)

Table 12 (continued) Abbreviations for adaptive turn-on and turn-off phases in PWM configuration

Abbreviation	Definition
IPREDCHGz	Pre-discharge-current sunk by the gate driver mapped to the PWM channel z during tPDCHGz. Internal and self-adaptive parameter. (AGC = (1,0) or (1,1), GENCTRL2) IPREDCHGz is clamped between I_{DCHG0} and IDCHGMAXz.
IPDCHGINITz	Initial value of IPREDCHGz. Refer to PWM_PDCHG_INIT
ICHGz	Current sourced by the gate driver mapped to the PWM channel z during the charge phase. See control register PWM_ICHG_ACT.
IDCHGz	Current sunk by the gate driver mapped to the PWM channel z during the discharge phase. See control register PWM_IDCHG_ACT.
ICHGFWz	Current source or sunk by the gate driver to turn on / turn off the freewheeling MOSFET of the half-bridge mapped to the PWM channel z. See PWM_ICHG_ACT.
tPCHGz	Duration of the pre-charge phase of PWM channel z. tPCHGz is configurable by SPI. See control register TPRECHG, configuration bits TPCHGz[1:0].
tPDCHGz	Duration of the pre-discharge phase of PWM channel z. tPDCHGz is configurable by SPI. See control register TPRECHG, configuration bits TPDCHGz[1:0].
tDONz	Turn-on delay of the PWM MOSFET mapped to the PWM channel z: <ul style="list-style-type: none"> for high-side PWM: time between the end of the cross-current protection and when VSHx increases to V_{SHL} (Figure 17). for low-side PWM: time between the end of the cross-current protection and when VSHx decreases to V_{SHH}.
tDOFFz	Turn-off delay of the PWM MOSFET mapped to the PWM channel z: <ul style="list-style-type: none"> for high-side PWM: time between the end of the symmetrization delay (t_{HBxCCP}) and when VSHx decreases to V_{SHH} (Figure 18). for low-side PWM: time between the end of the symmetrization delay (t_{HBxCCP}) and when VSHx increases to V_{SHL}.
IHOLD	Hold current sourced or sunk by the gate driver to keep the MOSFET in the desired state. See IHOLD control bit in GENCTRL2.
IHARDOFF	IHARDOFF is the maximum current that the gate drivers can sink. It corresponds to the discharge current when IDCHGx[4:0] = 31 _D (100 mA typ.).
TFVDS	Drain-Source overvoltage filter time. See GENCTRL2.

5.3.3.1 High-side PWM with adaptive gate control, motor operating as load

The following section describes the MOSFET control when the PWM signal is applied to the high-side MOSFET of one half-bridge while the motor operates.

Assumption: the PWM channel z , $z = 1, 2$ or 3 , is applied to the high-side MOSFET of the half-bridge x , $x = 1 \dots 8$.

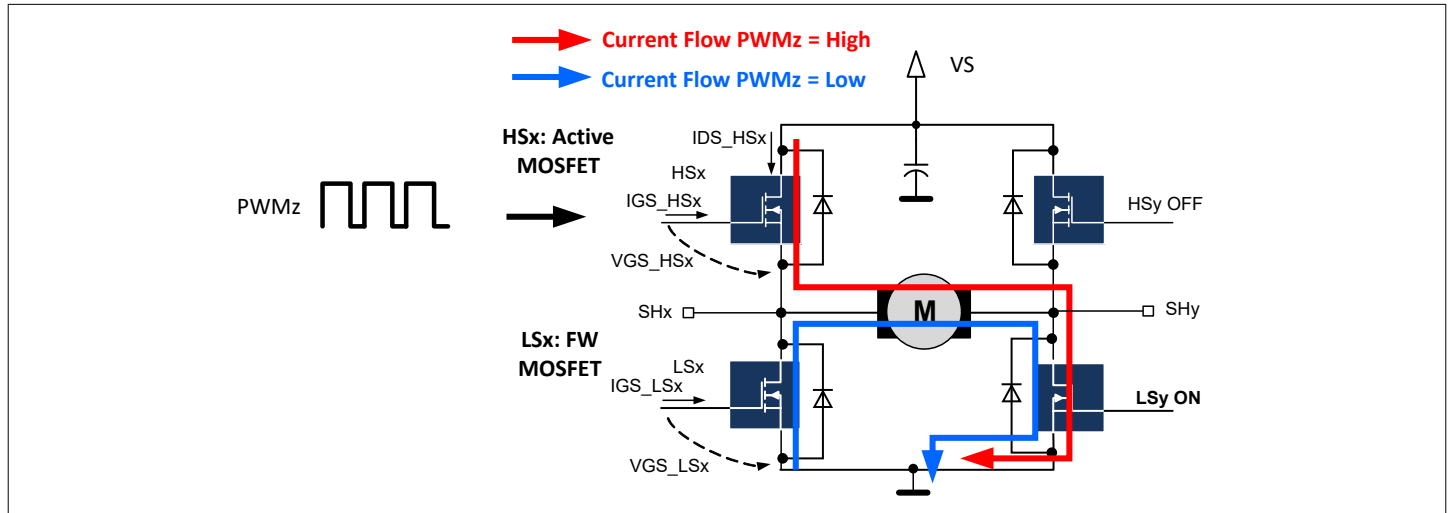

Figure 16 PWM channel z is mapped to high-side x , motor operating as load

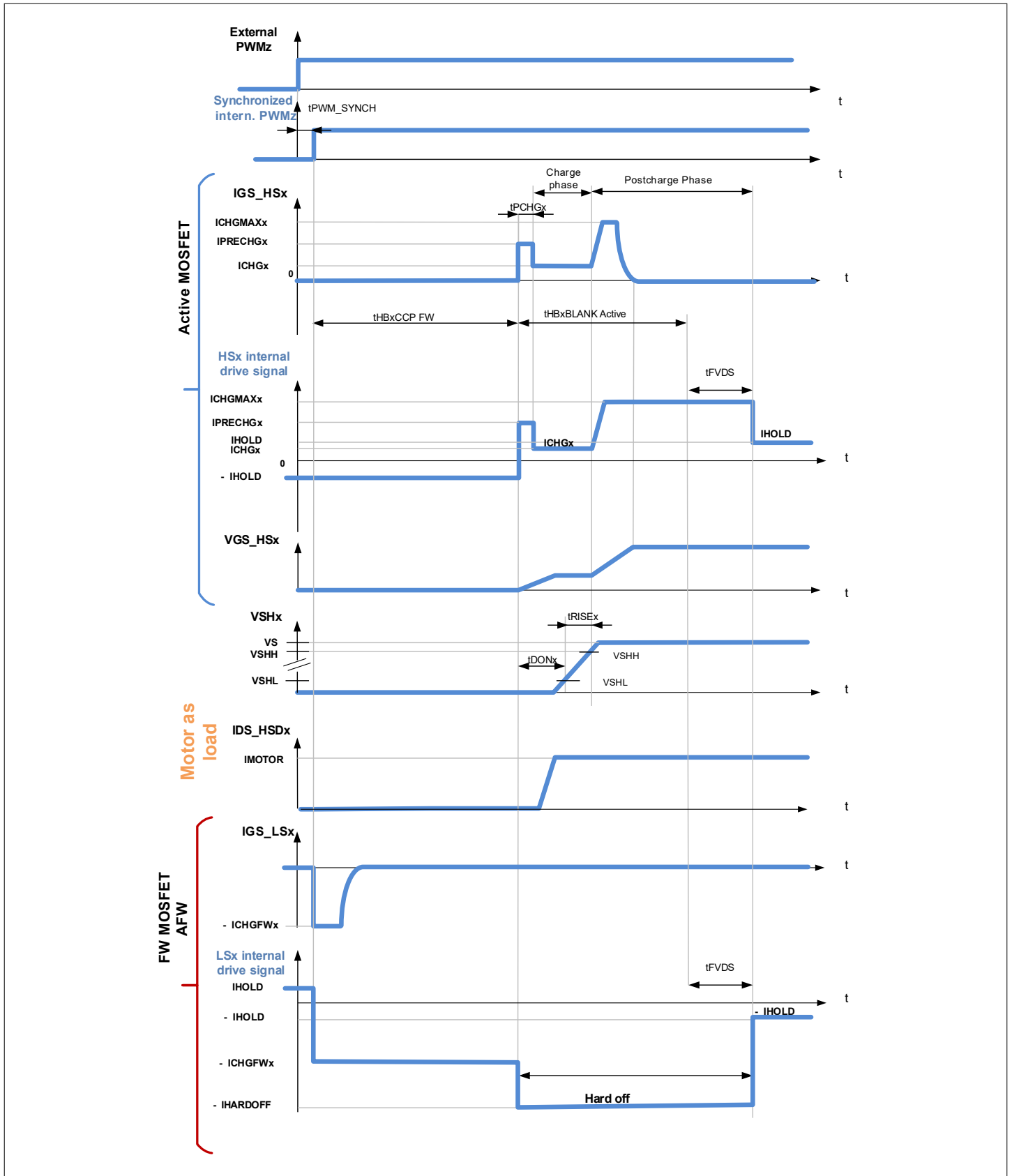

Figure 17 Adaptive turn-on, high-side PWM, AGC[1:0] = (1,0) or (1,1), motor operating as load
Adaptive turn-on during high-side PWM

The turn-on of the high-side MOSFET is done in four phases (Refer to Figure 17):

- Cross-current protection phase:** The cross-current protection tHBxCCP FW starts at the rising edge of the internal PWMz signal⁴. During tHBxCCP FW, the low-side MOSFET x is turned off with the discharge current - ICHGFWx, while the high-side MOSFET x is kept off.
- Pre-charge:** Once tHBxCCP FW has elapsed, the gate of the high-side MOSFET x is pre-charged with the current IPRECHGz for a duration tPCHGz. IPRECHGz⁵ is an internal parameter, which is self-adaptive (see next phase).
- Charge:** After tPCHGz, the charge current is decreased from IPRECHGz down to ICHGz. The effective tDONz⁶ is measured and compared to the configured tDONz for the automatic adaptation of IPRECHGz (see [Adaptive control of pre-charge current](#)). The charge phase ends up when V_{SHx} reaches VSHH.
- Post-charge:** After the charge phase, the control signal for the charge current of HSx is increased by one current step every 62.5 ns typ. to ICHGMAXx.

Note: The postcharge phase is deactivated by setting [POCHGDIS](#) to 1. Refer to [GENCTRL2](#).

Adaptive control of pre-charge current

Refer to [Chapter 5.3.6](#) for information on the pre-discharge currents.

The pre-charge current IPRECHGz is a self-adaptive parameter if $AGC[1:0] = (1,0)$ or $(1,1)$ (see [GENCTRL2](#)). It is applied during tPCHGz (see [TPRECHG](#)). The TLE92108-232QX adapts IPRECHGz to match the effective tDONz to the configured value.

IPRECHGz is clamped between I_{CHG0} (1 mA typ.) and ICHGMAXz (see [PWM_ICHGMAX_CCP_BLK3_ACT](#)).

IPRECHGz is initialized to $\min(IPCHGINITz, ICHGMAXz)$ (refer to [PWM_PCHG_INIT](#)) when the TLE92108-232QX receives an SPI command setting PWMz_EN to 1 (see [PWMSET](#)).

The following adaptive schemes can be selected:

AGCFILT = 0 ([GENCTRL2](#)): No filter is applied

- If the effective tDONz is longer than the configured tDONz, then IPRECHGz is increased during the next pre-charge phase.
- If the effective tDONz is shorter than the configured tDONz, then IPRECHGz is decreased during the next pre-charge phase.
- The pre-charge current is increased or decreased by one, respectively by two current steps ([Chapter 5.3.6](#)) if the control bit IPCHGADT in the control register [GENCTRL1](#) is set to 0 respectively 1.

AGCFILT = 1: The filter is applied

- If the effective tDONz **of the last two PWM cycles** are longer than the configured tDONz, then IPRECHGz is increased during the next pre-charge phase.
- If the effective tDONz **of the last two PWM cycles** are shorter than the configured tDONz, then IPRECHGz is decreased during the next pre-charge phase.
- The pre-charge current is increased or decreased by one, respectively by two current steps ([Chapter 5.3.6](#)) if the control bit IPCHGADT in the control register [GENCTRL1](#) is set to 0 respectively 1.
- If none of the two cases are applicable, then IPRECHGz is unchanged during the next pre-charge phase.

⁴ The external PWMz signal is synchronized with the internal device clock, resulting in the delay t_{PWM_SYNCH} between the internal and the external PWMz signals.

⁵ IPRECHGz is clamped between ICHGMAXz and I_{CHG0} .

⁶ The effective tDON can be read out. Refer to [EFF_TDON_OFF1](#), [EFF_TDON_OFF2](#), [EFF_TDON_OFF3](#)

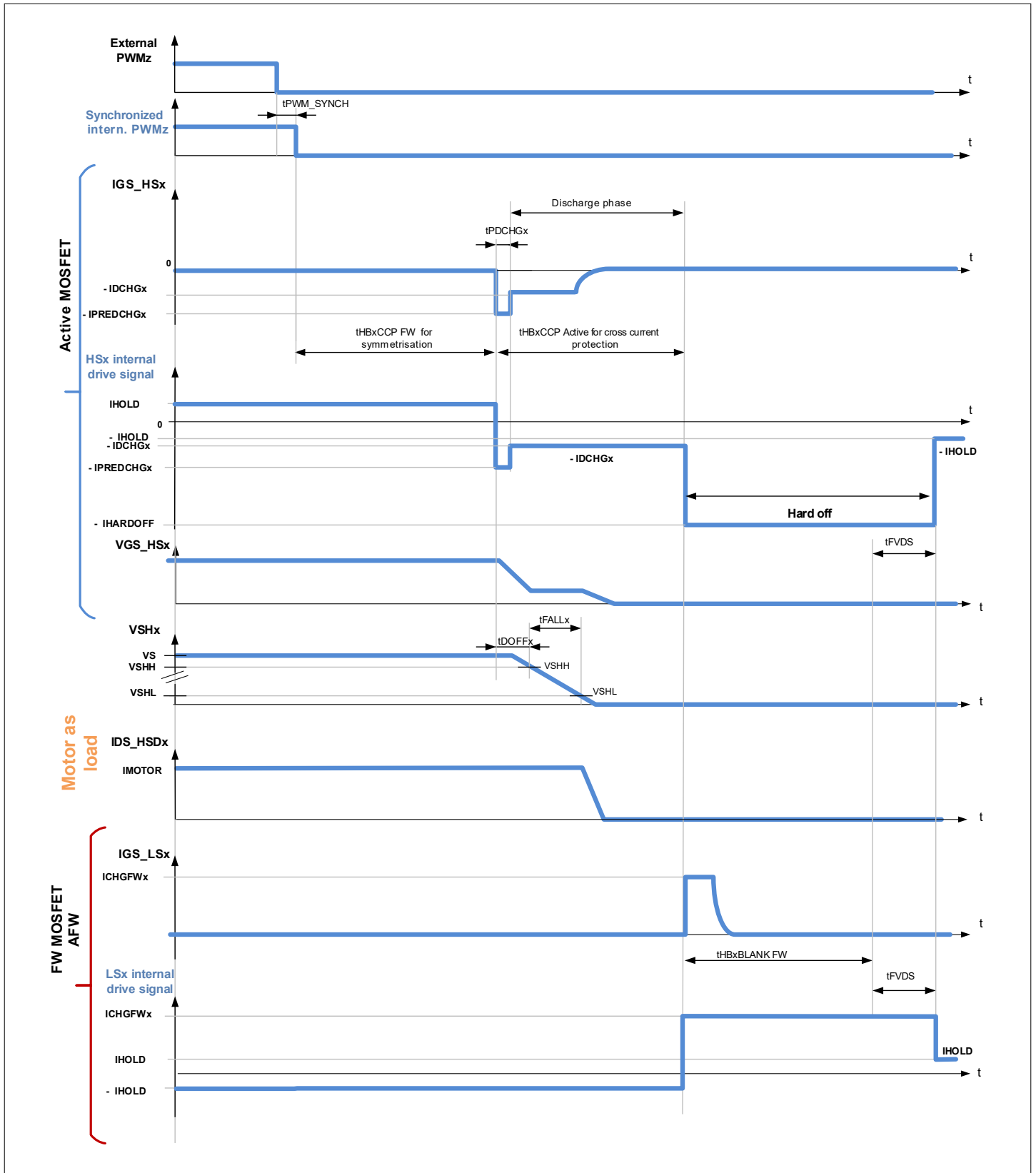

Figure 18 Adaptive turn-off, high-side PWM, AGC[1:0] = (1,0) or (1,1), motor operating as load

Adaptive turn-off during high-side PWM

The turn-off of the high-side MOSFET is done in four phases (Refer to [Figure 18](#)):

- Turn-off delay time for symmetrization** of the PWM signal: The turn-off of HSx is delayed by tHBxCCP FW after the falling edge of the internal PWMz signal⁷, in order to compensate the distortion caused by the cross-current protection time at turn-on.
- Pre-discharge:** once tHBxCCP FW for symmetrization has elapsed, the gate of the high-side MOSFET x is pre-discharged with the current - IPREDCHGz for a duration tDPCHGz. IPREDCHGz is a device internal parameter, which is self-adaptive (See next phase).
- Discharge:** After tDPCHGz, the pre-discharge current is decreased in absolute value from IPREDCHGz⁸ down to IDCHGz. The effective tDOFF⁹ is measured and compared to the configured tDOFFz for the automatic adaptation of IPREDCHGz (see [Adaptive control of pre-discharge current](#)). The discharge phase ends up at expiration of tHBxCCP active for cross-current protection.
- Cross-current protection phase:** The cross-current protection is concurrent to the pre-discharge and discharge of the high-side MOSFET. The cross-current protection phase starts when the turn-off delay for symmetrization ends up. It has the duration tHBxCCP active. During tHBxCCP active, the low-side MOSFETx is kept OFF. When tHBxCCP active has elapsed, the gate of the low-side MOSFET x is charged with the current ICHGFWz until the end of tFVDS, provided that $V_{SHx} < V_{SHL}$.

Adaptive control of pre-discharge current

Refer to [Chapter 5.3.6](#) for information on the pre-discharge currents.

The pre-discharge current IPREDCHGz is a self-adaptive parameter if AGC[1:0] = (1,0) or (1,1) (see [GENCTRL2](#)). The TLE92108-232QX adapts the IPREDCHGz to match the measured t_{DOFFz} to the configured value.

IPREDCHGz is clamped between I_{DCHG0} (1 mA typ.) and ICHGMAXz (see [PWM_ICHGMAX_CCP_BLK3_ACT](#)).

IPREDCHGz is initialized to min(IPDCHGINITz, ICHGMAXz) (refer to [PWM_PDCHG_INIT](#)) when the TLE92108-232QX receives a SPI command setting PWMz_EN to 1 (see [PWMSET](#))

The pre-discharge current is increased or decreased by one, respectively by two current steps ([Chapter 5.3.6](#)) if the control bit IPCHGADT in the control register [GENCTRL1](#) is set to 0 respectively 1.

The following adaptive schemes can be selected:

AGCFILT = 0 ([GENCTRL2](#)): No filter is applied

- If the effective tDOFFz is longer than the configured tDOFFz, then IPREDCHGz is increased during the next pre-discharge phase
- If the effective tDOFFz is shorter than the configured tDOFFz, then IPREDCHGz is decreased during the next pre-discharge phase
- The pre-charge current is increased or decreased by one, respectively by two current steps ([Chapter 5.3.6](#)) if the control bit IPCHGADT in the control register [GENCTRL1](#) is set to 0 respectively 1.

AGCFILT = 1: The filter is applied

- If the effective tDOFFz **of the last two PWM cycles** are longer than the configured tDOFFz, then IPREDCHGz is increased during the next pre-charge phase.
- If the effective tDOFFz **of the last two PWM cycles** are shorter than the configured tDOFFz, then IPREDCHGz is decreased during the next pre-charge phase.
- If none of the two cases are applicable, then IPREDCHGz is unchanged during the next pre-charge phase.
- The pre-charge current is increased or decreased by one, respectively by two current steps if the control bit IPCHGADT is set to 0 respectively 1.

⁷ The external PWMz signal is synchronized with the internal device clock, resulting in the delay t_{PWM_SYNCH} between the internal and the external PWMz signals.

⁸ IPREDCHGz is clamped between ICHGMAXz and I_{DCHG0} .

⁹ The effective tDOFF can be read out. Refer to [EFF_TDON_OFF1](#), [EFF_TDON_OFF2](#), [EFF_TDON_OFF3](#)

5.3.3.2 Low-side PWM with adaptive gate control, motor operating as load

The following section describes the MOSFET control when the PWM signal is applied to the low-side MOSFET of one half-bridge.

Assumption: the PWM channel z , $z = 1, 2$ or 3 , is applied to the low-side MOSFET of the half-bridge x , $x = 1 \dots 8$ (Figure 19).

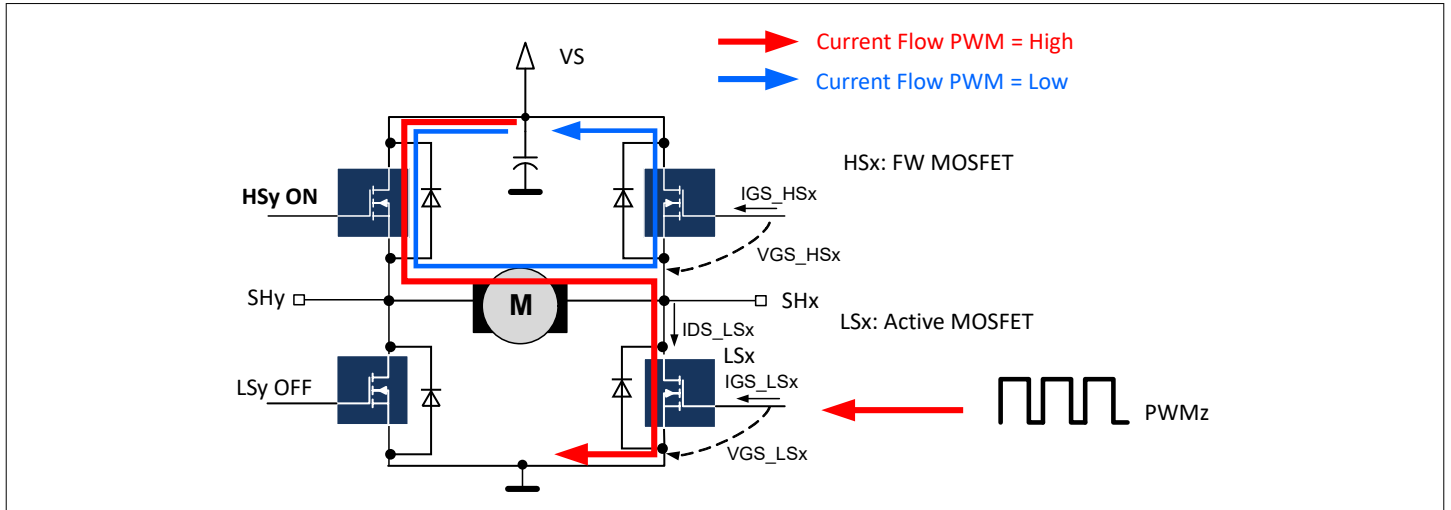

Figure 19 PWM Channel z is mapped to low-side x , motor operating as load

The description of the control of the PWM half-bridge differs from the description of Chapter 5.3.3.1 only by exchanging high-side x and low-side x and the thresholds $VSHH$ and $VSHL$.

5.3.3.3 High-side PWM with adaptive gate control, motor operating as generator

The control scheme during high-side PWM in generator mode (refer to Figure 20) is equivalent to low-side MOSFET in load mode with the complementary signal of the external PWM input.

The turn-on, turn-off delay times and the rise and fall times are applied and measured for the active MOSFET.

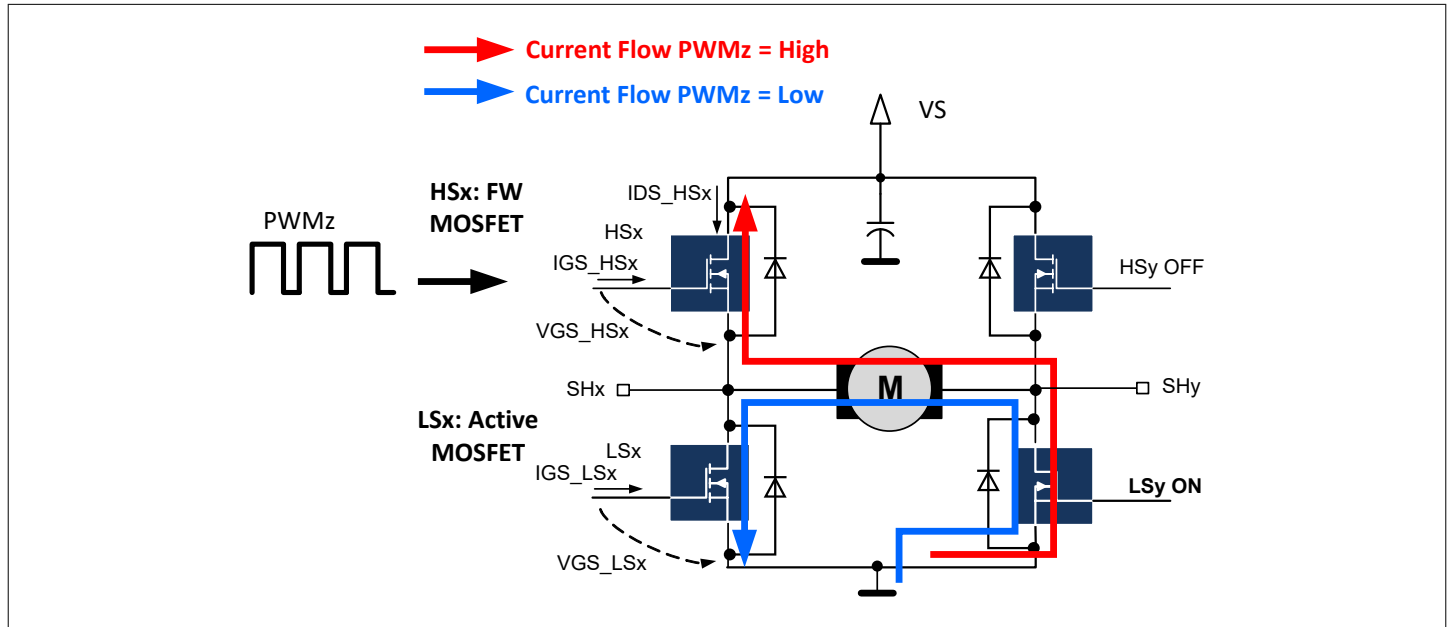

Figure 20 PWM input z is mapped to high-side x, the motor operating as generator

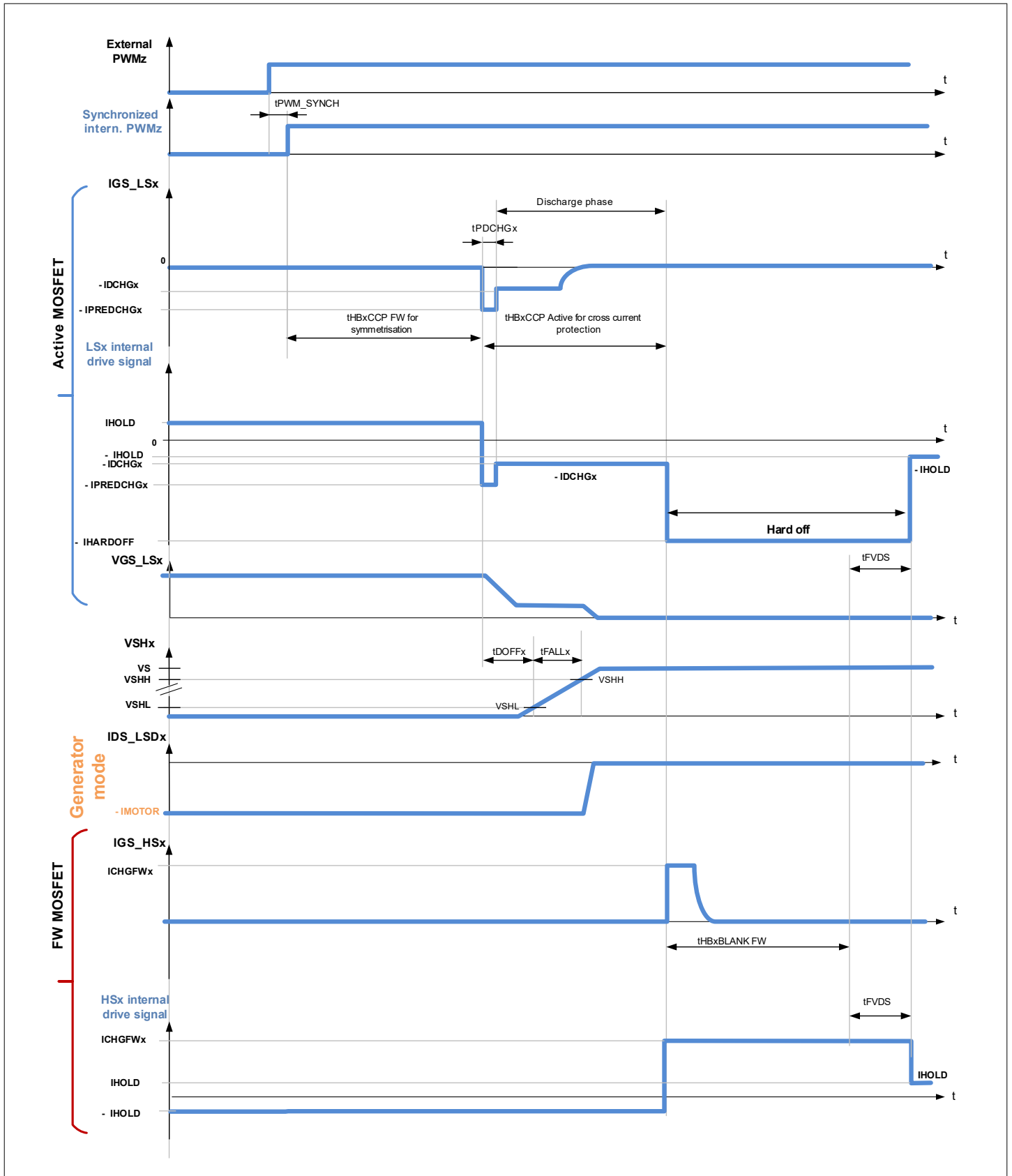

Figure 21 Adaptive turn-on, high-side PWM, AGC[1:0] = (1,0) or (1,1), motor operating as generator

5.3.3.4 Low-side PWM with adaptive gate control, motor operating as generator

The control scheme during high-side PWM in generator mode (refer to Figure 20) is equivalent to low-side PWM in load mode with the complementary signal of the external PWM input.

The turn-on, turn-off delay times and the rise and fall times are applied and measured for the active MOSFET.

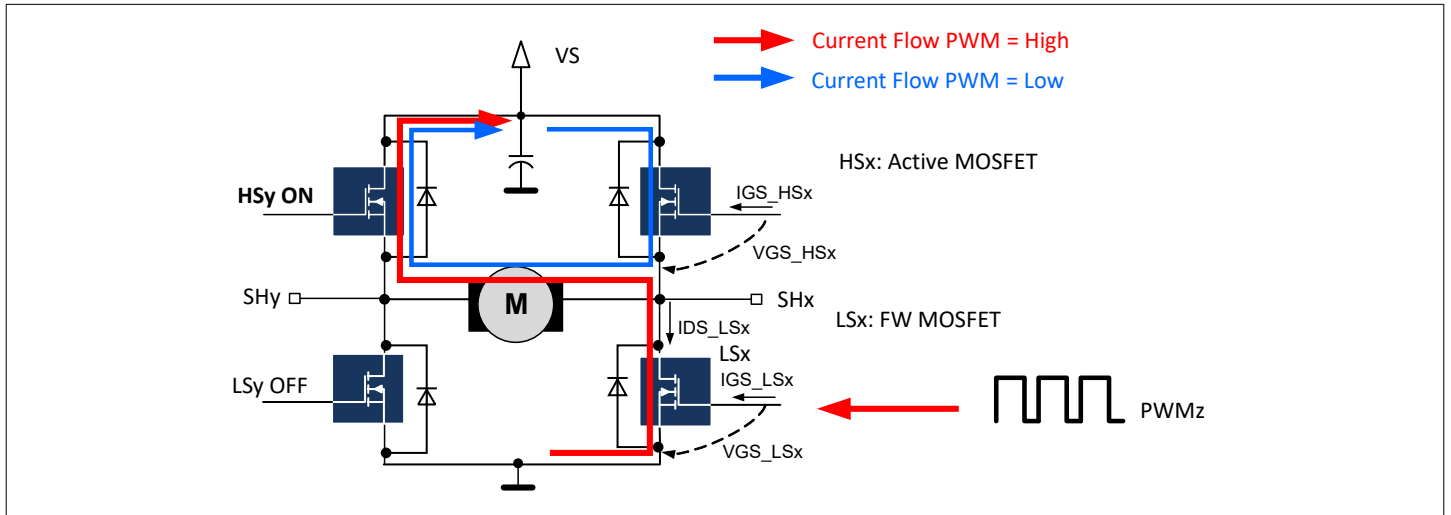

Figure 22 PWM input z is mapped to low-side x, the motor operating as generator

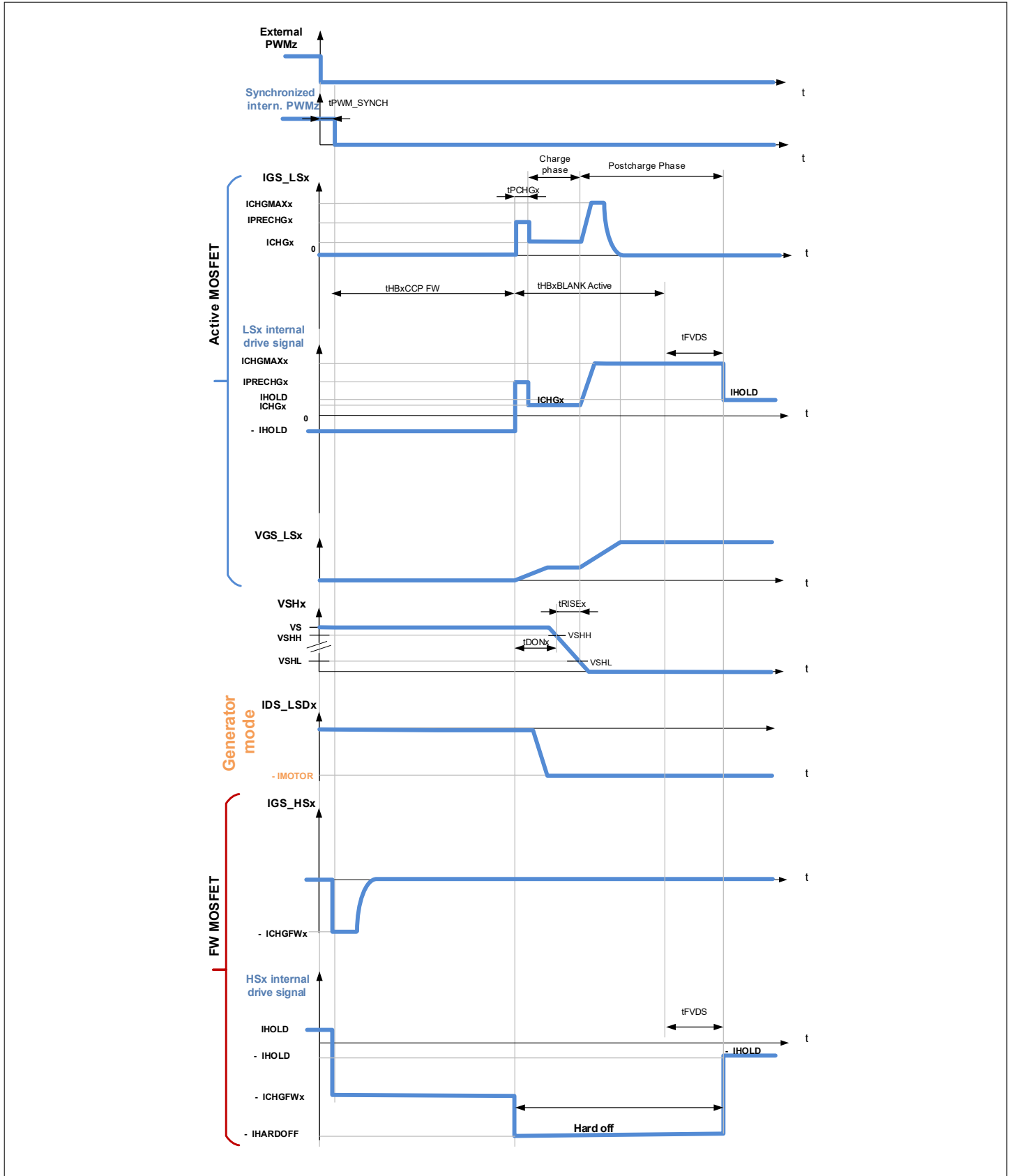

Figure 23 Adaptive turn-off with high-side PWM, AGC[1:0] = (1,0) or (1,1), motor operating as generator

5.3.3.5 Status bits for regulation of turn-on and turn-off delay times

The control bits TDREGx ([GENSTAT](#)) indicate if tDONx and tDOFFx of the PWM channel x using the adaptive gate control scheme (AGC[1:0] = 10_B or 11_B) is in regulation.

The PWM channel is considered in regulation if one of the following conditions are met:

- the effective turn-on and turn-off delays are equal to the configured delays for at least eight consecutive PWM cycles
- the error between the effective and configured delay changes its sign at least three times during the last 8 PWM cycles

5.3.3.6 Precharge and predischARGE phases with EN_DEEP_AD = 1

This section is valid if [EN_DEEP_AD](#) = 1. Enabling this feature leads to a lower granularity of the resulting precharge and predischARGE currents.

This principle is illustrated with an example during the precharge phase on [Figure 24](#). The same principle is applied to the predischARGE phase.

If [EN_DEEP_AD](#) = 1:

- The precharge phase can be divided in two parts, during which different precharge current steps are applied
- The predischARGE phase can be divided in two parts, during which different predischARGE current steps are applied

The device exits the “deep adaptation mode” if t_{DON} , respectively t_{DOFF} , cannot be regulated and the resolution of the precharge time cannot be further divided. Then, one single current step is applied during the precharge time ([Figure 25](#)).

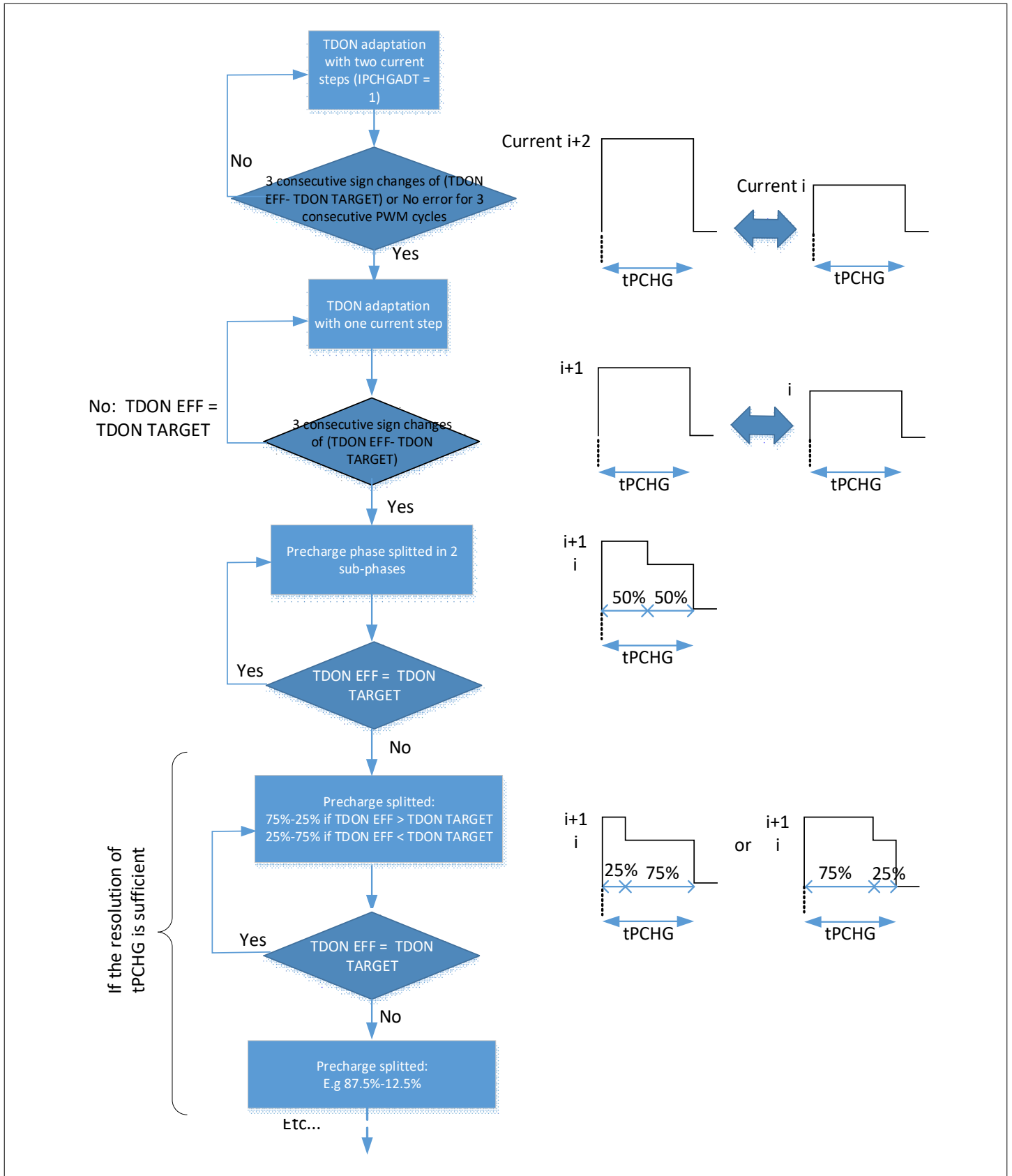

Figure 24 Example of precharge current modulation during the precharge phase, EN_DEEP_AD = 1

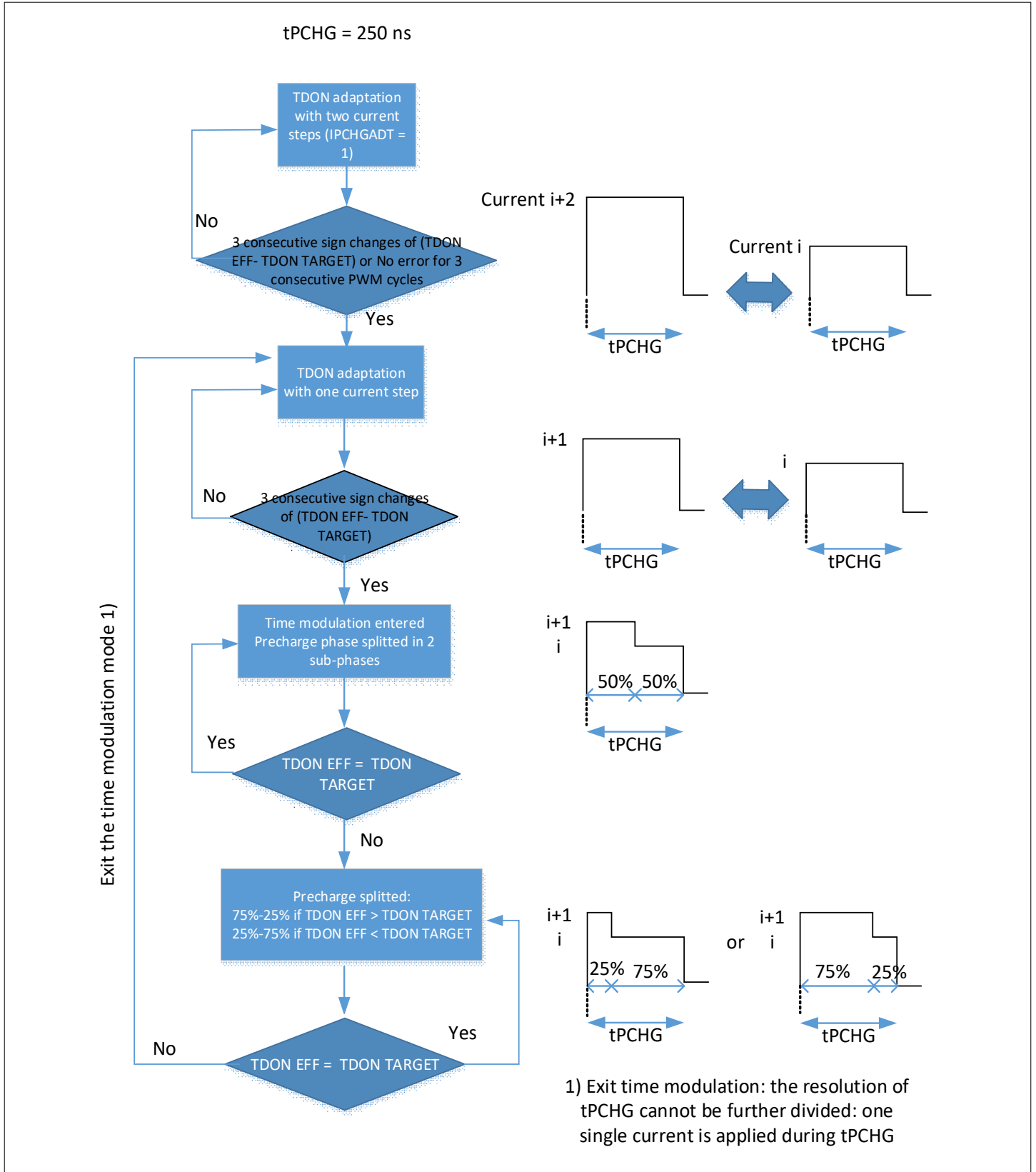

Figure 25 Criteria to exit the time modulation, EN_DEEP_AD = 1

5.3.4 PWM operation without adaptive gate control

The adaptive gate control is disabled if AGC[1:0] is set to (0,0) or (0,1). The effective turn-on and turn-off delays of the PWM MOSFETs are not regulated. Two modes can be selected.

The target turn-on and turn-off delay times of PWM MOSFETs (configured in [TDON_OFF1](#), [TDON_OFF2](#), [TDON_OFF3](#)) are no longer regulated. Nevertheless the status registers [EFF_TDON_OFF1](#), [EFF_TDON_OFF2](#), [EFF_TDON_OFF3](#) still report the effective turn-on and turn-off times of the PWM MOSFET.

5.3.4.1 PWM operation without adaptive gate control, AGC[1:0] = (0,0)

When AGC[1:0] = (0,0) (see [GENCTRL2](#)), the control of the gate drivers in PWM mode differs from the description of [Chapter 5.3.3, PWM operation with adaptive gate control](#), only by the suppression of the pre-charge and pre-discharge phases.

5.3.4.2 PWM operation without adaptive gate control, AGC[1:0] = (0,1)

When AGC[1:0] = (0,1) (see [GENCTRL2](#)), the control of the gate drivers in PWM mode differs from the description of [Chapter 5.3.4.1, PWM operation without adaptive gate control, AGC\[1:0\] = \(0,0\)](#), only by the addition of a pre-discharge phase. During tPDCHGz, the gate of the PWM MOSFET mapped to the PWM channel z is discharged with the current -IPDCHGINITz (Refer to [PWM_PDCHG_INIT](#)).

Refer to [Figure 26](#) for the turn-off of the PWM MOSFET with high-side PWM.

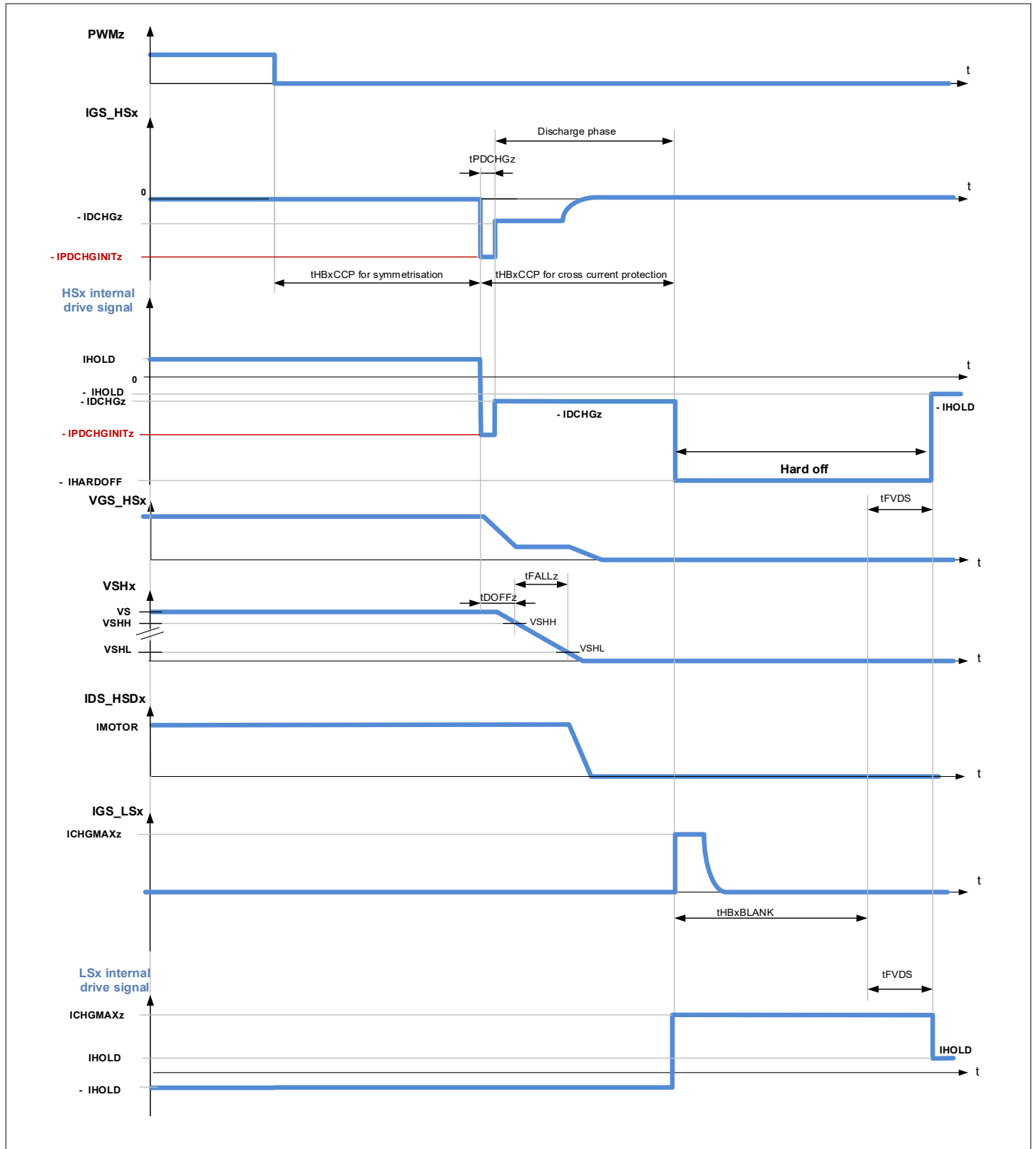

Figure 26 High-side PWM operation - turn-off without adaptive gate control, AGC[1:0] = (0,1)

5.3.5 PWM operation at high and low duty cycles

This section describes the internal PWM signal of the active and FW MOSFET when the motor operates as load or generator. In particular, at low and high duty cycles, the active free-wheeling is disabled.

Note: It is recommended to clear `EN_GEN_CHECK` (`EN_GEN_CHECK` to 0) at very high or very low duty cycles: $t_{ON} < t_{HBxCCP\ FW}$ or $t_{OFF} < t_{HBxCCP\ active}$. Under these conditions, a generator mode cannot be correctly detected. The control scheme of the active MOSFET and of the freewheeling MOSFET can therefore be inverted.

Note: The device cannot measure the switching times t_{DON} , t_{DOFF} , t_{RISE} and t_{FALL} at very high or very low duty cycles: $t_{ON} < t_{HBxCCP\ FW}$ or $t_{OFF} < t_{HBxCCP\ active}$.

General case, motor operating as load, $t_{ON} > t_{HBxCCP\ FW}$ and $t_{OFF} > t_{HBxCCP\ active}$

Figure 27 shows the internal control signals of the PWM MOSFETs and the freewheeling MOSFET while the motor operates as load :

- t_{ON} is longer than the FW cross-current protection time ($t_{HBxCCP\ FW}$)
- t_{OFF} is longer than the active cross-current protection time ($t_{HBxCCP\ Active}$)

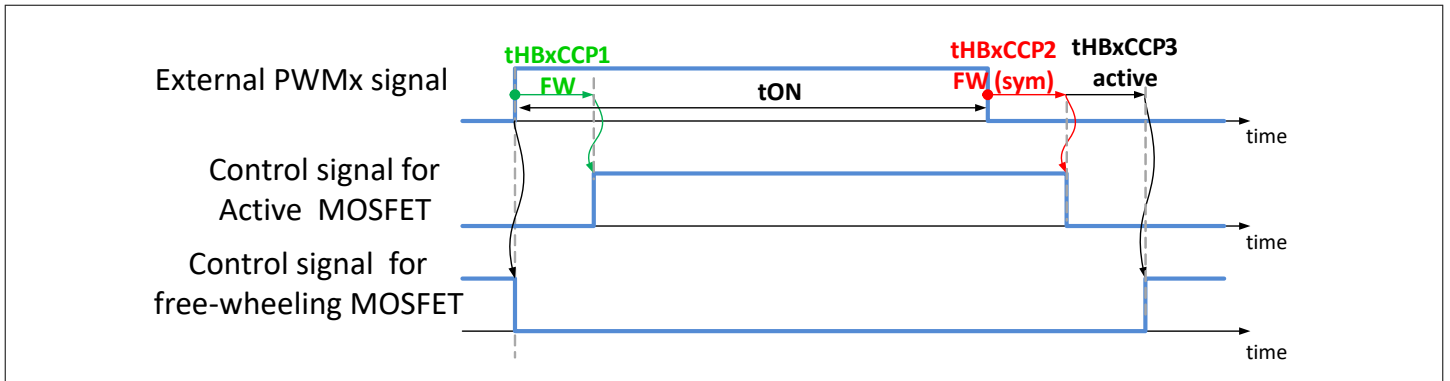

Figure 27 Internal signals for PWM operation - General case $t_{ON} > t_{HBxCCP\ FW}$, $t_{OFF} > t_{HBxCCP\ active}$, motor operating as load

General case, motor operating as generator, $t_{OFF} > t_{HBxCCP\ FW}$ and $t_{ON} > t_{HBxCCP\ active}$

Figure 28 shows the internal control signals of the PWM MOSFETs and the freewheeling MOSFET while the motor operates as generator:

- t_{OFF} is longer than the FW cross-current protection time ($t_{HBxCCP\ FW}$)
- t_{ON} is longer than the active cross-current protection time ($t_{HBxCCP\ Active}$)

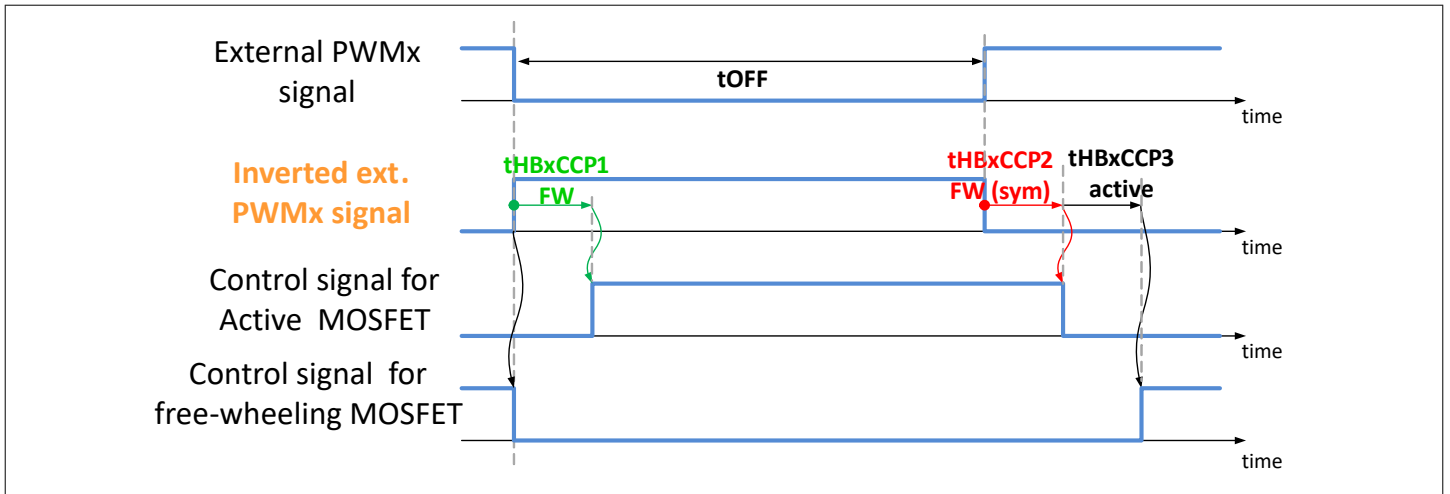

Figure 28 Internal signals for PWM operation - General case: $t_{OFF} > t_{HBxCCP}$ FW, $t_{ON} > t_{HBxCCP}$ active, motor operating as generator

High duty cycle: $t_{OFF} < t_{HBxCCP}$ active

No distinction between active MOSFET and FW MOSFET is possible, when the OFF-time of the external PWM signal is shorter than the configured active cross-current protection time. Therefore the PWM MOSFET (selected by HBxMODE[1:0]) is controlled as the active MOSFET. In other words, it is assumed that the motor operates as load. The control signal of the PWM MOSFET is shifted by one FW cross-current protection time compared to the external PWM signal. The MOSFET opposite to the PWM MOSFET stays OFF (passive FW). Refer to [Figure 29](#).

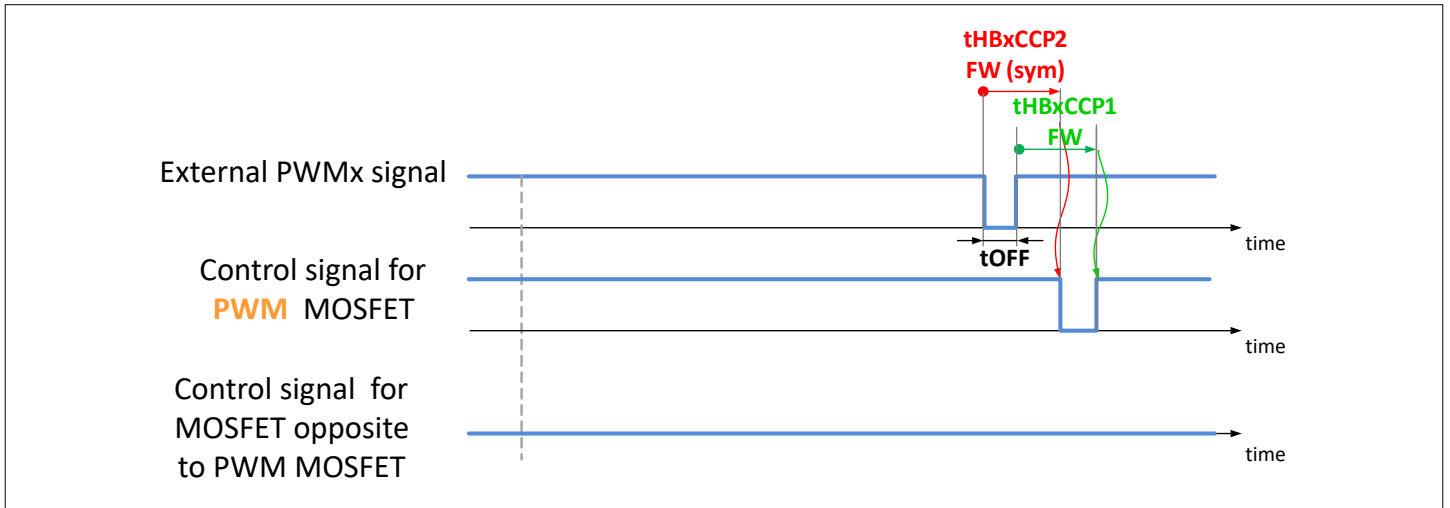

Figure 29 Internal signals for PWM operation at high duty cycle, $t_{OFF} < t_{HBxCCP}$ active

Low duty cycle: $t_{ON} < t_{HBxCCP}$ FW

No distinction between active MOSFET and FW MOSFET is possible, when the ON-time of the external PWM signal is shorter than the configured FW cross-current protection time. Therefore the PWM MOSFET (selected by HBxMODE[1:0]) is controlled as the active MOSFET. In other words, it is assumed that the motor operates as load. The control signal of the PWM MOSFET is shifted by one cross-current protection time compared to the external PWM signal. Refer to [Figure 30](#).

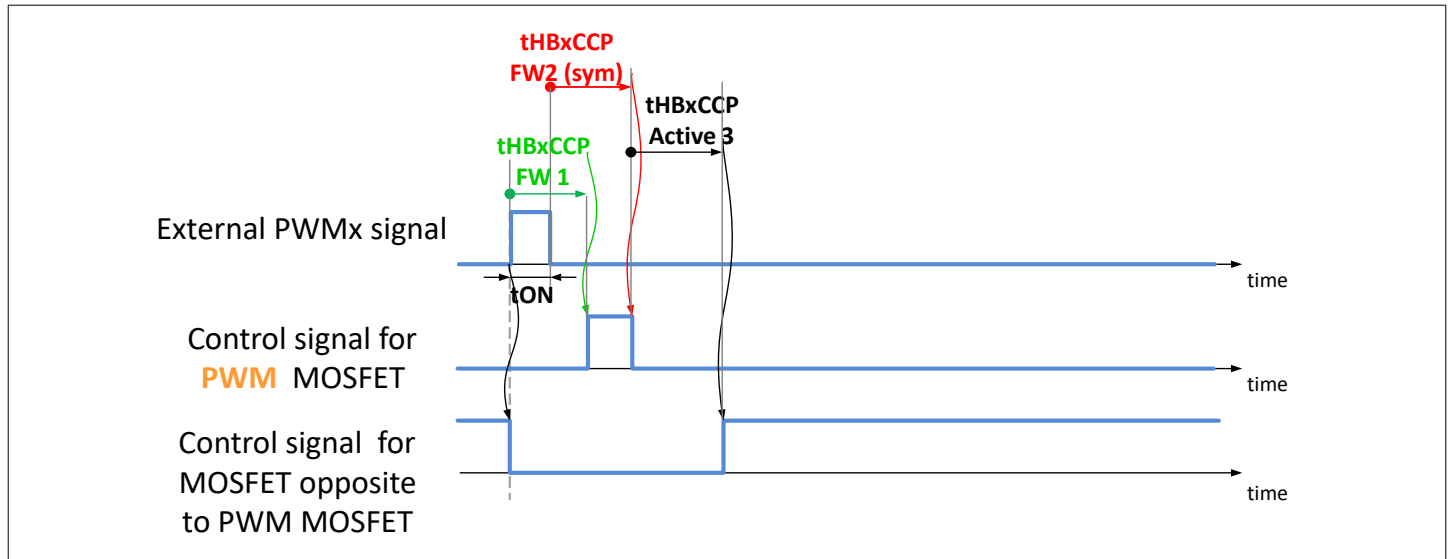

Figure 30 Internal signals for PWM operation at low duty cycle, $t_{ON} < t_{HBxCCP}$ FW

5.3.6 Gate driver current

Each gate driver is able to source and sink currents from 1.0 mA to 100 mA, with 32 steps according to [Figure 31](#) and [Figure 32](#).

The charge and discharge currents of the active and the FW MOSFETs are configured separately by:

- The `REG_BANK` bit (`GENCTRL1`)
- The control registers `PWM_ICHG_ACT`, `PWM_IDCHG_ACT`, `PWM_ICHG_FW`

The charge current of the active MOSFETs are configured by `PWM_ICHG_ACT` (`REG_BANK = 0`)

The discharge current of the active MOSFETs are configured by `PWM_IDCHG_ACT` (`REG_BANK = 0`)

The charge and discharge current of the FW MOSFET are configured by `PWM_ICHG_FW` (`REG_BANK = 1`)

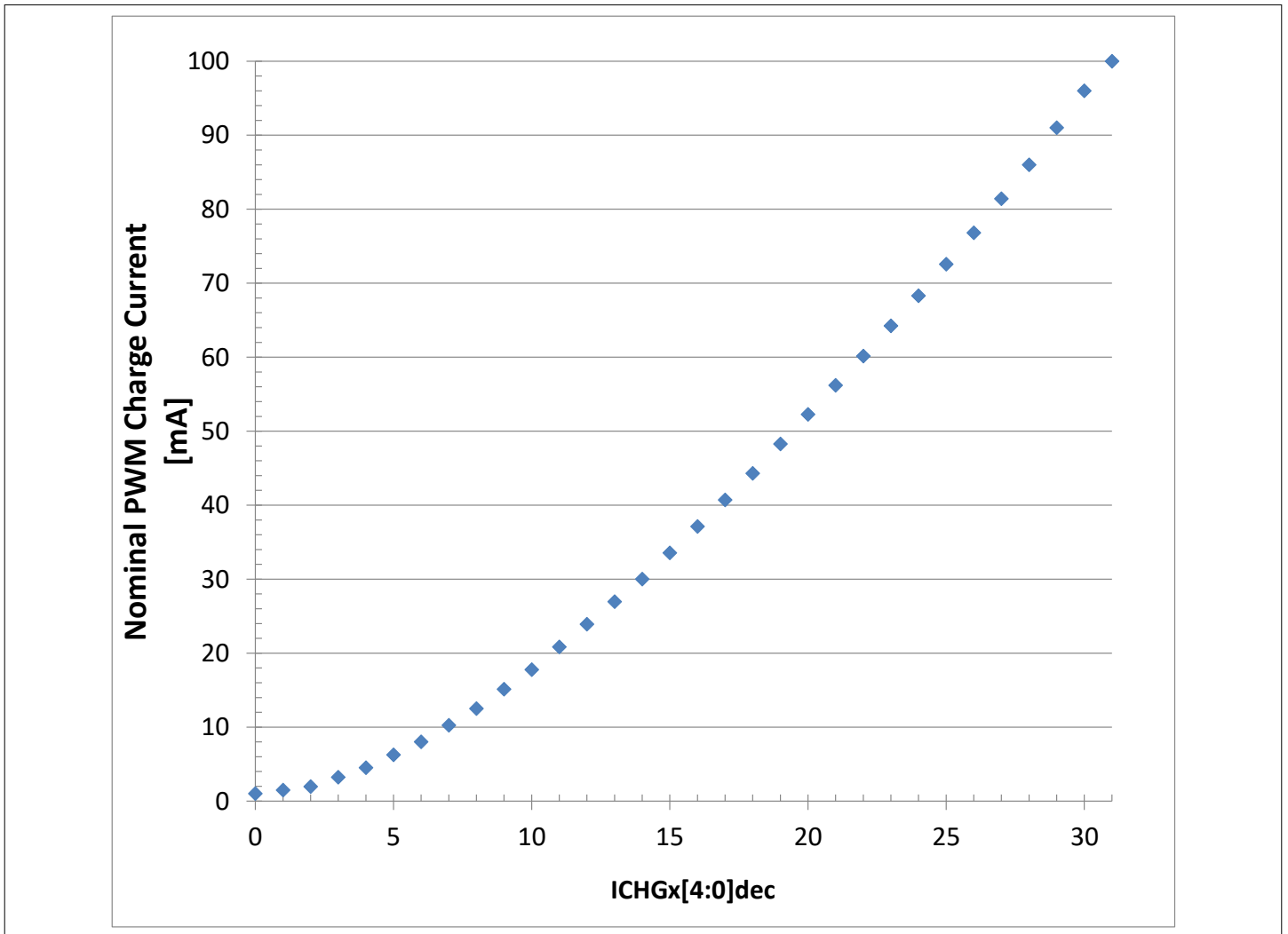

Figure 31 Configurable charge currents in PWM operation

Table 13 Charge currents in PWM operation

ICHGx[4:0], ICHGxFW[4:0], IPCHGINITx[4:0]	Nom. charge current [mA] ¹⁾	Max. deviation to nominal values [%]
00000 _B	1.0	+/- 60 %
00001 _B	1.5	+/- 60 %

(table continues...)

Table 13 (continued) Charge currents in PWM operation

ICHGx[4:0], ICHGxFW[4:0], IPCHGINITx[4:0]	Nom. charge current [mA] ¹⁾	Max. deviation to nominal values [%]
00010 _B	2.0	+/- 60 %
00011 _B	3.2	+/- 60 %
00100 _B	4.5	+/- 60 %
00101 _B	6.3	+/- 60 %
00110 _B	8.0	+/- 38 %
00111 _B	10.3	+/- 38 %
01000 _B	12.5	+/- 38 %
01001 _B	15.1	+/- 38 %
01010 _B	17.8	+/- 38 %
01011 _B	20.8	+/- 38 %
01100 _B	23.9	+/- 38 %
01101 _B	27.0	+/- 38 %
01110 _B	30.0	+/- 28 %
01111 _B	33.5	+/- 28 %
10000 _B	37.1	+/- 28 %
10001 _B	40.7	+/- 28 %
10010 _B	44.3	+/- 28 %
10011 _B	48.3	+/- 28 %
10100 _B	52.3	+/- 28 %
10101 _B	56.2	+/- 28 %
10110 _B	60.1	+/- 28 %
10111 _B	64.2	+/- 28 %
11000 _B	68.3	+/- 28 %
11001 _B	72.5	+/- 28 %
11010 _B	76.8	+/- 28 %
11011 _B	81.4	+/- 28 %
11100 _B	86.0	+/- 28 %
11101 _B	91.0	+/- 28 %
11110 _B	96.0	+/- 25 %
11111 _B	100	+/- 25 %

1) $V_S \geq 8V$ and $V_{GS} \leq V_{GS(ON)1}$ if ICHGx/ICHGxFW $\leq 14_D$, $V_S \geq 8V$ and $V_{GS} \leq V_{GS(ON)2}$ if ICHGx/ICHGxFW $\geq 15_D$

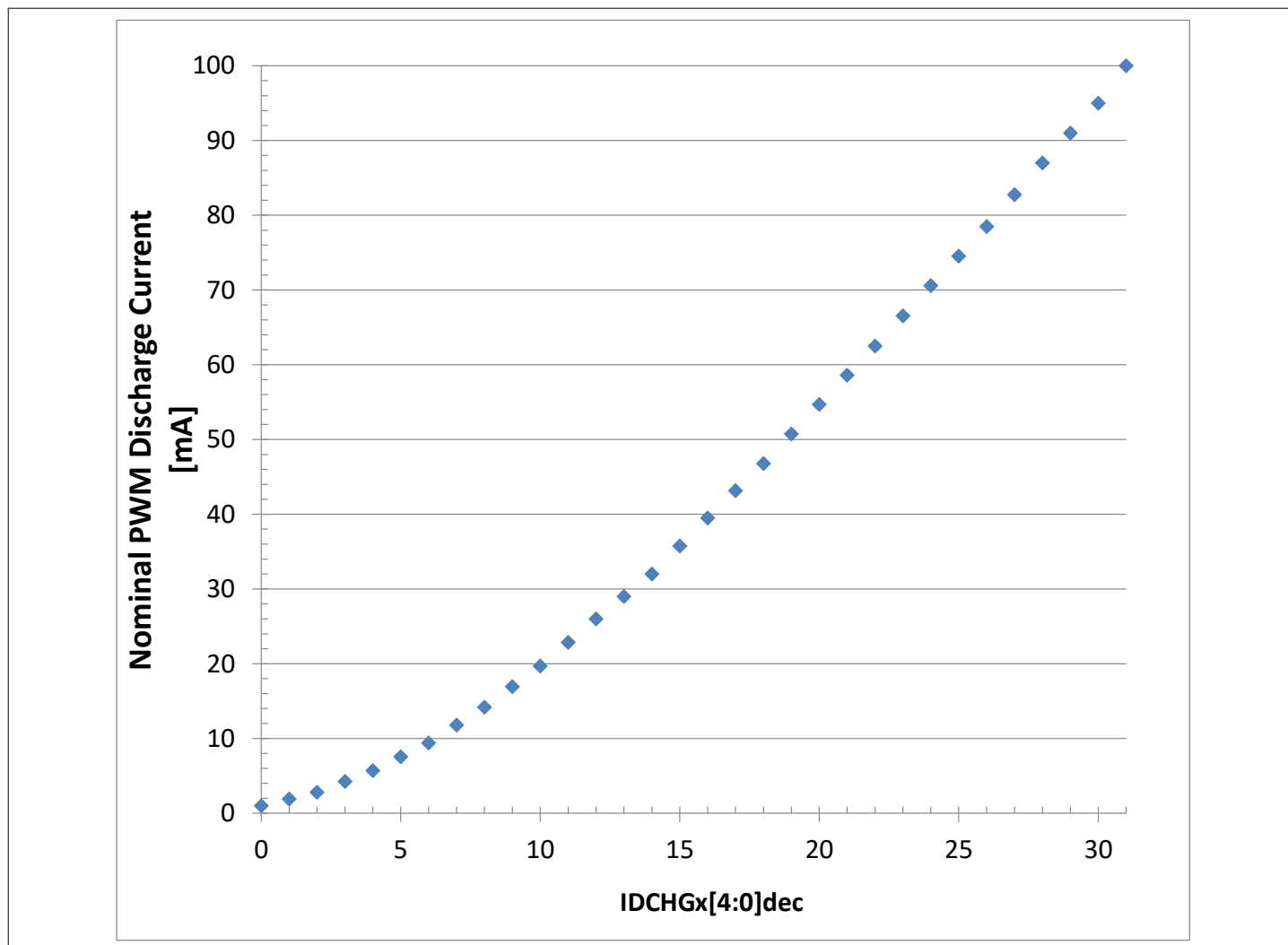

Figure 32 Configurable discharge currents in PWM operation

Table 14 Discharge currents in PWM operation

IDCHGx[4:0], IDCHGxFW[4:0], IPDCHGINITx[4:0]	Nom. discharge current [mA] ¹⁾	Max. deviation to nominal values [%]
0000 _B	1.0	+/- 60 %
00001 _B	1.9	+/- 60 %
00010 _B	2.8	+/- 60 %
00011 _B	4.3	+/- 60 %
00100 _B	5.7	+/- 60 %
00101 _B	7.5	+/- 60 %
00110 _B	9.4	+/- 38 %
00111 _B	11.8	+/- 38 %
01000 _B	14.2	+/- 38 %
01001 _B	17.0	+/- 38 %

(table continues...)

Table 14 (continued) Discharge currents in PWM operation

IDCHGx[4:0], IDCHGxFW[4:0], IPDCHGINITx[4:0]	Nom. discharge current [mA]¹⁾	Max. deviation to nominal values [%]
01010 _B	19.7	+/- 38 %
01011 _B	22.9	+/- 38 %
01100 _B	26.0	+/- 38 %
01101 _B	29.0	+/- 38 %
01110 _B	32.0	+/- 28 %
01111 _B	35.8	+/- 28 %
10000 _B	39.5	+/- 28 %
10001 _B	43.1	+/- 28 %
10010 _B	46.8	+/- 28 %
10011 _B	50.8	+/- 28 %
10100 _B	54.7	+/- 28 %
10101 _B	58.6	+/- 28 %
10110 _B	62.5	+/- 28 %
10111 _B	66.6	+/- 28 %
11000 _B	70.6	+/- 28 %
11001 _B	74.6	+/- 28 %
11010 _B	78.5	+/- 28 %
11011 _B	82.8	+/- 28 %
11100 _B	87.0	+/- 28 %
11101 _B	91.0	+/- 28 %
11110 _B	95.0	+/- 25 %
11111 _B	100	+/- 25 %

1) $V_{GS} \geq V_{GS(OFF)1}$ if $IDCHGx \leq 14_D$, $V_{GS} \geq V_{GS(OFF)2}$ if $IDCHGxFW \geq 15_D$

5.4 Passive discharge

Resistors (R_{GGND}) between the gate of GHx and GND, and between GLx and GND, ensure that the external MOSFETs are turned off, when EN = Low or when $V_{DD} < V_{DDPOFFR}$.

During normal mode with **BD_PASS** bit reset (**GENCTRL2**) without failure causing the deactivation of the gate drivers, these pull-down resistors are switched off. The MOSFET are actively kept off with the discharge current IHOLD.

During normal mode with failure leading to the deactivation of the gate drivers (charge pump undervoltage, VS undervoltage and overvoltage, thermal shutdown) or in fail safe mode, R_{GGND} are activated, independently from the setting of **BD_PASS**.

Gate driver power down

The gate driver is deactivated in normal mode with **BD_PASS** set to 1 **and** all HBxMODE[1:0]=00 or 11. The current consumption of the VS input is reduced to **IS_BD_PASS** and R_{GGND} are activated.

5.5 Bridge driver in passive mode

The low-side MOSFETs LS1, LS2, LS3 and LS4 can be controlled when the bridge driver in the passive mode. All the other MOSFETs kept off by the passive discharge.

The bridge driver is in passive mode:

- If **BD_PASS** = 1 in normal mode and all HBxMODE[1:0]=00_B or 11_B.
- In sleep mode (EN = Low).
- If $V_{DD} < V_{DDPOFFR}$.

When the bridge driver is in passive mode, then the state of the low-side MOSFETs LS1-LS4 is configured by **PASS_MOD**.¹⁰⁾

- If **PASS_MOD**[1:0] = 00_B: LS1, LS2, LS3 and LS4 are off (passive discharge).
- If **PASS_MOD**[1:0] = 01_B: LS1, LS2, LS3 and LS4 are on (static brake).
- If **PASS_MOD**[1:0] = 10_B: LS1, LS2, LS3 and LS4 are turned on if $V_S > V_{SOV PASS OFF}$ (overvoltage brake). The PWM3 pin is pulled down by an internal open drain (**RPWM3_OD**).
- If **PASS_MOD**[1:0] = 11_B: LS1, LS2, LS3 and LS4 are turned on if PWM1 = High and $V_S > V_{SOV PASS OFF}$ (overvoltage brake conditioned by PWM1). The PWM3 pin is pulled down by an internal open drain (**RPWM3_OD**).

LS1, LS2, LS3 and LS4 MOSFETs with an input capacitor up to 10 nF are turned on within **tON_BD_PASS**.

The setting of LS1-LS4 according to **PASS_MOD** in sleep mode or if $V_{DD} < V_{DDPOFFR}$ is valid only if V_S stays above **VSLEEP_SET**. If V_S drops below **VSLEEP_SET**, then LS1-LS4 behave as if **PASS_MOD** = 10_B, the latter setting is kept even after a V_S recovery. Note that the quiescent current is changed accordingly.

¹⁰⁾ If **BD_PASS** = 0, the setting by **PASS_MOD**[1:0] is effective only when EN=0 or $V_{DD} < V_{DDPOFFR}$

5.6 Electrical characteristics gate driver

The electrical characteristics related to the gate driver are valid for $V_{CP} > V_S + 8.5 \text{ V}$.

Table 15 Electrical characteristics: gate drivers

$V_S = 6.0 \text{ V}$ to 18 V if $V_{SOVTH} = 0$, $V_S = 6.0 \text{ V}$ to 28 V if $V_{SOVTH} = 1$; $V_{DD} = 3.0 \text{ V}$ to 5.5 V , $T_j = -40^\circ\text{C}$ to 150°C

$V_{CP} > V_S + 8.5 \text{ V}$, all voltages with respect to ground. Positive current flowing into pin except for I_{GLx} and I_{GHx} (unless otherwise specified).

Parameter	Symbol	Values			Unit	Note or Test Condition	Number
		Min.	Typ.	Max.			
Comparators							
SHx High Threshold	V_{SHH}	$V_S - 2.5$	–	$V_S - 2.0$	V		P_6.5.1
SHx Low Threshold	V_{SHL}	2	–	2.5	V	Referred to GND	P_6.5.2
SHx comparator delay	t_{SHx}	–	5	30	ns	¹⁾	P_6.5.26
MOSFET Driver Output							
High Level Output Voltage GHx vs. SHx and GLx vs. SL, CPSTGA= 0	V_{GH1}	10	–	12.2	V	$V_S > 8 \text{ V}$ $C_{Load} = 10 \text{ nF}$ $I_{CP} = -12 \text{ mA}^{2)}$	P_6.5.3
High Level Output Voltage GHx vs. SHx and GLx vs. SL, CPSTGA= 0	V_{GH3}	7	–	–	V	$V_S > 6.0 \text{ V}$ $C_{Load} = 10 \text{ nF}$ $I_{CP} = -6 \text{ mA}^{2)}$	P_6.5.5
High Level Output Voltage GHx vs. SHx and GLx vs. SL, CPSTGA= 1	V_{GH4}	10	–	12.2	V	¹⁾ $V_S > 18 \text{ V}$, $C_{Load} = 10 \text{ nF}$ $I_{CP} = -12 \text{ mA}^{2)}$	P_6.5.6
Charge current	I_{CHG0}	0.4	1.0	1.6	mA	$I_{CHG} = 0_D$ $C_{Load} = 10 \text{ nF}$ $V_{GS} \leq V_{GS(ON)1}$	P_6.5.30
Charge current	I_{CHG6}	5.0	8.0	11.0	mA	$I_{CHG} = 6_D$ $C_{Load} = 10 \text{ nF}$ $V_{GS} \leq V_{GS(ON)1}$	P_6.5.31
Charge current	I_{CHG14}	21.6	30.0	38.4	mA	$I_{CHG} = 14_D$ $C_{Load} = 10 \text{ nF}$ $V_{GS} \leq V_{GS(ON)1}$	P_6.5.33
Charge current	I_{CHG30}	72	96	120	mA	$I_{CHG} = 30_D$ $C_{Load} = 10 \text{ nF}$ $V_{GS} \leq V_{GS(ON)2}$	P_6.5.35
Discharge current	I_{DCHG0}	-1.6	-1.0	-0.4	mA	$I_{DCHG} = 0_D$ $C_{Load} = 10 \text{ nF}$ $V_{GS} \geq V_{GS(OFF)1}$	P_6.5.36

(table continues...)

Table 15 (continued) Electrical characteristics: gate drivers

$V_S = 6.0\text{ V to }18\text{ V}$ if $V_{SOVTH} = 0$, $V_S = 6.0\text{ V to }28\text{ V}$ if $V_{SOVTH} = 1$; $V_{DD} = 3.0\text{ V to }5.5\text{ V}$, $T_j = -40^\circ\text{C to }150^\circ\text{C}$

$V_{CP} > V_S + 8.5\text{ V}$, all voltages with respect to ground. Positive current flowing into pin except for I_{GLx} and I_{GHx} (unless otherwise specified).

Parameter	Symbol	Values			Unit	Note or Test Condition	Number
		Min.	Typ.	Max.			
Discharge current	I_{DCHG6}	-13.0	-9.4	-5.8	mA	$IDCHG = 6_D$ $C_{Load} = 10\text{ nF}$ $V_{GS} \geq V_{GS(OFF)1}$	P_6.5.37
Discharge current	I_{DCHG14}	-41.0	-32.0	-23.0	mA	$IDCHG = 14_D$ $C_{Load} = 10\text{ nF}$ $V_{GS} \geq V_{GS(OFF)1}$	P_6.5.39
Discharge current	I_{DCHG30}	-119	-95	-71	mA	$IDCHG = 30_D$ $C_{Load} = 10\text{ nF}$ $V_{GS} \geq V_{GS(OFF)2}$	P_6.5.41
Passive discharge resistance between GHx/GLx and GND	R_{GGND}	10	20	30	k Ω	¹⁾	P_6.5.11
Resistor between SHx and GND	R_{SHGND}	10	20	30	k Ω	¹⁾	P_6.5.12
Low R _{DS(on)} mode	R_{ONCCP}	-	22	40	Ω	$V_S = 13.5\text{ V}$ $V_{CP} = V_S + 14\text{ V}$ $I_{CHG} = I_{DCHG} = 31$ (max)	P_6.5.13

Gate Drivers Dynamic Parameters

External MOSFET gate-to-source voltage - ON	$V_{GS(ON)1}$	9	-	-	V	¹⁾ $V_S \geq 8\text{ V}$ $ICHGx \leq 14_D$	P_6.5.50
External MOSFET gate-to-source voltage - ON	$V_{GS(ON)2}$	7	-	-	V	¹⁾ $V_S \geq 8\text{ V}$ $ICHGx \geq 15_D$	P_6.5.51
External MOSFET gate-to-source voltage - OFF	$V_{GS(OFF)1}$	-	-	2	V	¹⁾ $IDCHGx \leq 14_D$	P_6.5.52
External MOSFET gate-to-source voltage - OFF	$V_{GS(OFF)2}$	-	-	5	V	¹⁾ $IDCHGx \geq 15_D$	P_6.5.53
PWM synchronization delay	t_{PWM_SYNCH}	50	-	150	ns	¹⁾	P_6.5.46
Pre-charge time	t_{PCHG00}	100	125	150	ns	¹⁾ $TPCHG = 00_B$	P_6.5.18
Pre-charge time	t_{PCHG01}	200	250	300	ns	¹⁾ $TPCHG = 01_B$	P_6.5.19
Pre-charge time	t_{PCHG10}	400	500	600	ns	¹⁾ $TPCHG = 10_B$	P_6.5.20
Pre-charge time	t_{PCHG11}	800	1000	1200	ns	¹⁾ $TPCHG = 11_B$	P_6.5.21
Pre-discharge time	$t_{DPCHG00}$	100	125	150	ns	¹⁾ $TDPCHG = 00_B$	P_6.5.22
Pre-discharge time	$t_{DPCHG01}$	200	250	300	ns	¹⁾ $TDPCHG = 01_B$	P_6.5.23

(table continues...)

Table 15 (continued) Electrical characteristics: gate drivers

$V_S = 6.0\text{ V to }18\text{ V}$ if $V_{SOVTH} = 0$, $V_S = 6.0\text{ V to }28\text{ V}$ if $V_{SOVTH} = 1$; $V_{DD} = 3.0\text{ V to }5.5\text{ V}$, $T_j = -40^\circ\text{C to }150^\circ\text{C}$

$V_{CP} > V_S + 8.5\text{ V}$, all voltages with respect to ground. Positive current flowing into pin except for I_{GLx} and I_{GHx} (unless otherwise specified).

Parameter	Symbol	Values			Unit	Note or Test Condition	Number
		Min.	Typ.	Max.			
Pre-discharge time	$t_{DPCHG01}$	400	500	600	ns	¹⁾ TDPCHG = 10 _B	P_6.5.24
Pre-discharge time	$t_{DPCHG01}$	800	1000	1200	ns	¹⁾ TDPCHG = 11 _B	P_6.5.25

1) Not subject to production test, specified by design.

2) $I_{CHGx[4:0]} = 11111_{\text{B}}$ (100 mA typ.)

6 Protections and diagnostics

6.1 Reverse polarity protection

The output of the charge pump (CP pin) can be used to supply an external n-channel MOSFET, building an active reverse polarity protection. Refer to [Figure 50](#).

6.2 Safe switch (optional)

The output of the charge pump (CP pin) can be used to supply an optional external n-channel MOSFET, operating as safe switch. The safe switch can be actively turned off for example by the microcontroller or a safety logic, in order to disconnect the MOSFET supply, independently from the TLE92108-232QX. Refer to [Figure 50](#).

6.3 Drain-source voltage monitoring with bridge driver in active mode

When EN = High and [BD_PASS](#) = 0 (bridge driver in active mode), voltage comparators monitor the activated MOSFETs to protect the high-side MOSFETs and low-side MOSFETs against a short circuit respectively to ground and to the battery during ON-state.

If a Drain-Source overvoltage is detected, the corresponding half-bridge is latched off.

If $HBxD = 0$, $x = 1..8$ ([VDS1](#) and [VDS2](#)): The half-bridge x is latched off if the voltage difference between DH and $VSHx$ exceeds the threshold voltage configured by [VDS1](#), and [VDS2](#) (see [Table 16](#)).

If $HBxD = 1$, $x = 1..8$ (see [VDS1](#) and [VDS2](#)): The half-bridge x is latched off if the voltage difference between $CSIN1$ and $VSHx$ exceeds the threshold voltage configured by [VDS1](#), and [VDS2](#) (see [Table 16](#)).

Short circuits of low-side MOSFETs to VS are detected by monitoring the voltage difference between $VSHx$ and SL (see [Table 16](#)).

Table 16 Drain-Source overvoltage threshold, EN = High, [BD_PASS](#) = 0

HBxVDSTH¹⁾ [2:0]	Drain-Source overvoltage threshold for HSx and LSx¹⁾ (typical)
000 _B	150 mV
001 _B	200 mV (default)
010 _B	250 mV
011 _B	300 mV
100 _B	400 mV
101 _B	500 mV
110 _B	600 mV
111 _B	2 V

1) $x = 1 \dots 8$.

Attention: ***HBxVDSTH[2:0] = 111_B (2 V threshold) is dedicated for the diagnostic in off-state. It is highly recommended to select another drain-source overvoltage threshold once the routine of the diagnostic in off-state has been performed to avoid additional current consumption from VS and from the charge pump.***

The device reports a Drain-Source overvoltage error if both conditions are met:

- After expiration of the blank time.
- If the Drain-Source voltage monitoring exceeds the configured threshold for a duration longer than the configured filter time (refer to [Table 17](#) and [GENCTRL2](#) TFVDS bits).

- Note:**
- Exception with **static activated** MOSFETs when the short circuit is applied **before the expiration of the blank time**: the MOSFETs are turned off between **blank time + t_{FVDS}** and **blank time + $2 \times t_{FVDS}$**
 - Exception for active MOSFETs in PWM operation :
 - For a low-side MOSFET: When the LS MOSFET is turned off at the end of the PWM on-time, a drain-source overvoltage may be detected if the drain-source voltage is higher than the drain-source overvoltage threshold regardless of the filter time. The drain-source overvoltage is then reported to the low-side of the impacted half-bridge.
 - For a high-side MOSFET: When the HS MOSFET is turned off at the end of the PWM on-time, a drain-source overvoltage may be detected if the drain-source voltage is higher than the drain-source overvoltage threshold regardless of the filter time. The drain-source overvoltage is then reported to the **low-side** of the impacted half-bridge.

Table 17 Drain-Source overvoltage filter time

TFVDS[1:0]	Drain-Source overvoltage filter time (typical)
00 _B	0.5 μ s (default)
01 _B	1 μ s
10 _B	2 μ s
11 _B	3 μ s

If a short circuit is detected by the Drain-Source voltage monitoring:

- The impacted half-bridge is latched off.
 - The discharge current is according to the settings of [ST_ICHG](#), as if the MOSFET was previously statically activated.
- The corresponding bit in the status register [DSOV](#) is set.
- The VDSE in Global Status Register [Global status byte](#) is set.

If a Drain-Source overvoltage is detected for one of the MOSFETs, then the status register [DSOV](#) must be cleared in order to re-enable the faulty half-bridge.

6.4 Drain-source voltage monitoring with bridge driver in passive mode

LS1 to LS4 can be activated when the bridge driver is in passive mode (refer to [Chapter 5.5](#)).

A drain-source overvoltage monitoring of LS1, LS2, LS3 and LS4 MOSFETs is enabled if [PASS_VDS](#) is set.

The drain-source monitoring (VSHx - VSL, x = 1 to 4) is ignored for [tBLK_BD_PASS](#) (blank time) after beginning of the activation of LS1, LS2, LS3 and LS4 MOSFETs.

The drain-source monitoring filter time is [tDSMON_FILT_BD_PASS](#) and the VDS threshold is [VDSMON_BD_PASS](#) (370 mV typ).

If a drain-source overvoltage is detected, then:

- The LS1, LS2, LS3 and LS4 MOSFETs are turned off.
- [PASS_VDSOV](#) and the corresponding status bit in [DSOV](#) are set.

LS1-4 can be reactivated by clearing [DSOV](#). Clearing [DSOV](#) also clears [PASS_VDSOV](#).

6.5 Cross-current protection and drain-source overvoltage blank time

All gate drivers feature a cross-current protection time and a Drain-Source overvoltage blank times.

The cross-current protection avoids the simultaneous activation of the high-side and the low-side MOSFETs of the same half-bridge.

During the blank time, the drain-source overvoltage detection is disabled, to avoid a wrong fault detection during the activation phase of a MOSFET.

Notes:

1. The setting of the cross-current protection and of the blank times may be changed by the microcontroller only if all $PWMx_EN$ bits are reset, $x = 1 \dots 3$.
2. Changing the Drain-Source overvoltage of a half-bridge x (HBx) in on-state ($HBxMODE[1:0]=(0,1)$ or $(1,0)$) may result in a wrong VDS overvoltage detection on HBx . Therefore it is highly recommended to change this threshold when $HBxMODE[1:0]=(0,0)$ or $(1,1)$.

6.5.1 Cross-current protection

Four pairs of cross-current protection and blank times ($tCCPx$, $tBLANKx$), $x = 1 \dots 4$) can be mapped to each half-bridge with the control register [CCP_BLK1](#).

The cross-current protection time of the active MOSFET of the FW MOSFETs are set independently.

- The cross-current protection times of the active MOSFETs are configured by the control bits $TCCPx_ACT$ ([CCP_BLK2_ACT](#), [PWM_ICHGMAX_CCP_BLK3_ACT](#)) and [CCP_BLK1](#)
- The cross-current protection times of the free-wheeling MOSFETs are configured by the control bits $TCCPx_FW$ ([CCP_BLK2_FW](#), [PWM_ICHGMAX_CCP_BLK3_FW](#)) and [CCP_BLK1](#)

Table 18 Cross-current protection time

$TCCPx_ACT[2:0]$, $TCCPx_FW[2:0]$, $x = 1 \dots 4$	Cross-current protection time $tCCPx_ACT/tCCPx_FW$, $x = 1 \dots 4$ (typical)
000 _B	375 ns
001 _B	625 ns
010 _B	1 μ s
011 _B	1.5 μ s
100 _B	2 μ s (default)
101 _B	3 μ s
110 _B	4 μ s
111 _B	16 μ s ¹⁾

1) When applying a cross-current protection time of 16 μ s to a half-bridge, the max. drive current used for this half-bridge must be set below 30 mA to avoid an overheating of the gate driver.

6.5.2 Drain-source overvoltage blank time in bridge driver active mode

A configurable blank time (refer to [Table 19](#)) for the Drain-Source monitoring is applied at the turn-on of the MOSFETs. During the blank time, a Drain-Source overvoltage error is masked.

The blank time of the active MOSFET of the FW MOSFETs are set independently:

- The blank times of the active MOSFETs are configured by the control bits TBLANKx_ACT (CCP_BLK2_ACT, PWM_ICHGMAX_CCP_BLK3_ACT) and CCP_BLK1
- The blank times of the free-wheeling MOSFETs are configured by the control bits TBLANKx_FW (CCP_BLK2_FW, PWM_ICHGMAX_CCP_BLK3_FW) and CCP_BLK1

Half-bridges in PWM mode

If the detection of the generator mode is disabled (EN_GEN_CHECK = 0):

- The blank time of the PWM MOSFET starts at the expiration of the cross-current protection time of the FW MOSFET (tHBxCCP FW). Refer to Figure 33.
- The blank time of the FW MOSFET starts after expiration of the cross-current protection time at turn-off of the PWM MOSFET (tHBxCCP Active). Refer to Figure 33.

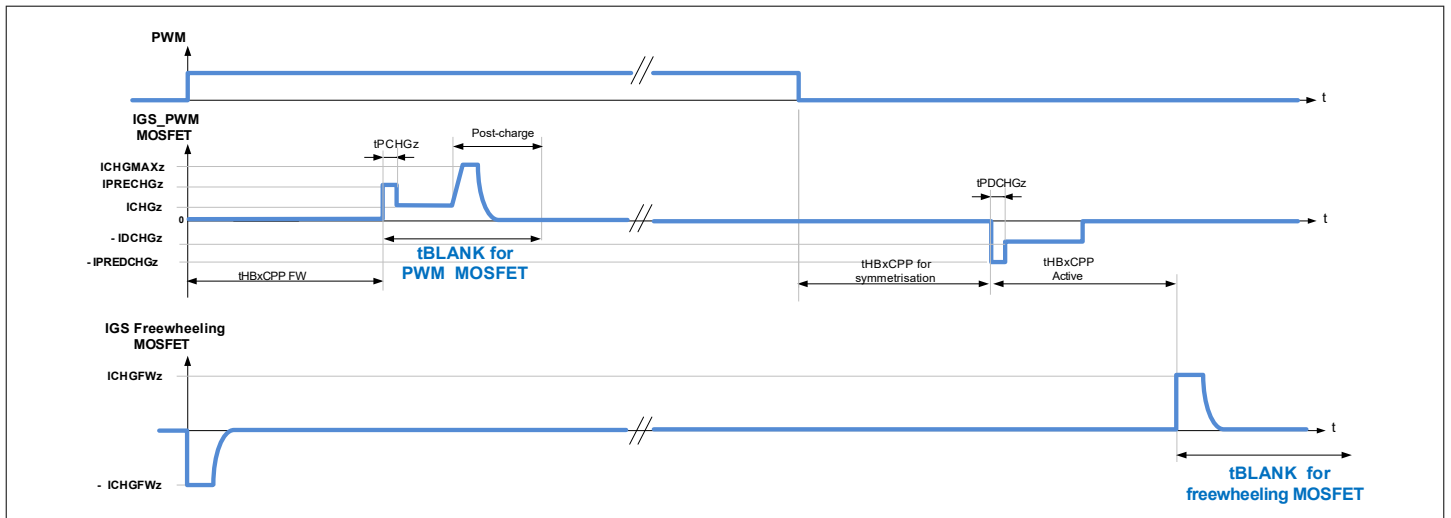

Figure 33 Blank time for half-bridges in PWM operation, detection of generator mode disabled (EN_GEN_CHECK = 0)

If the detection of the generator mode is enabled (EN_GEN_CHECK = 1):

- The blank time of the Active MOSFET starts at the expiration of the cross-current protection time of the FW MOSFET (tHBxCCP FW). Refer to Figure 34 and Figure 35.
- The blank time of the FW MOSFET starts after expiration of the cross-current protection time at turn-off of the Active MOSFET (tHBxCCP Active). Refer to Figure 34 and Figure 35.

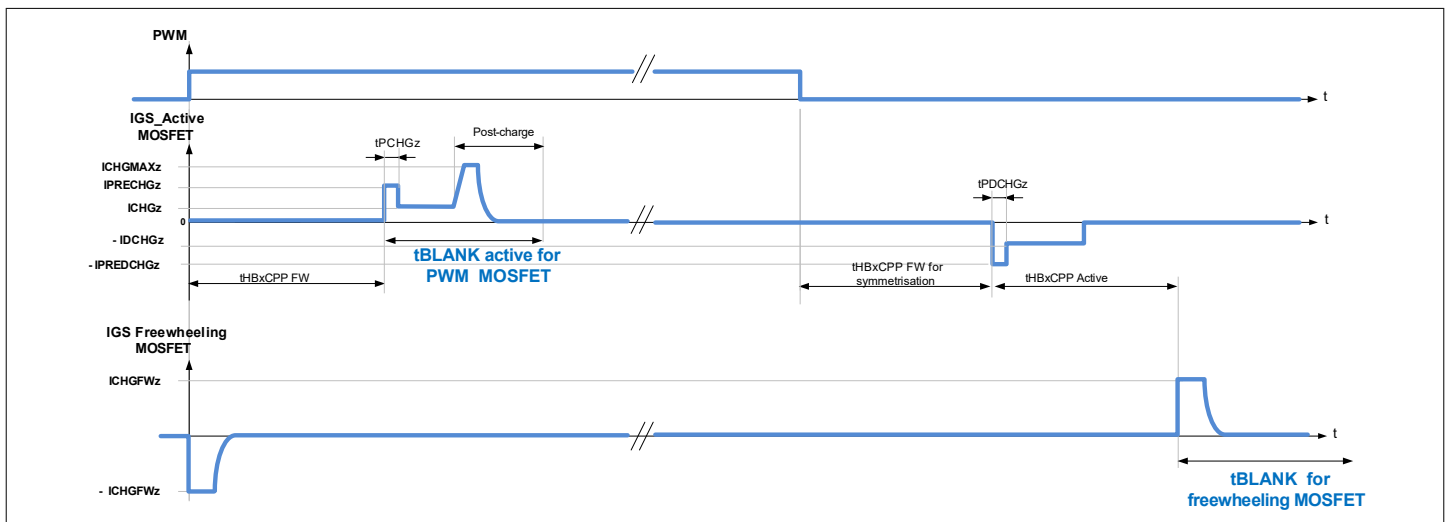

Figure 34 Blank time for half-bridges in PWM operation, detection of generator mode enabled (EN_GEN_CHECK = 1), motor operating as load

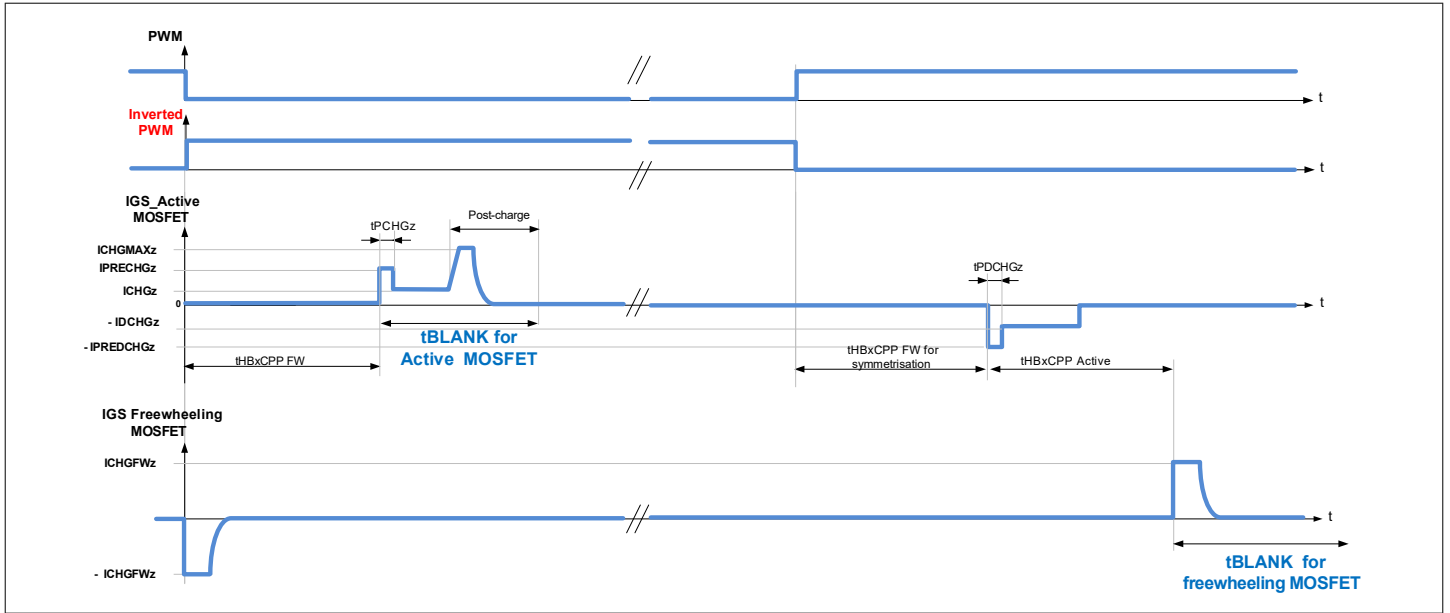

Figure 35 Blank time for half-bridges in PWM operation, detection of generator mode enabled (EN_GEN_CHECK = 1), motor operating as generator

For statically activated half-bridges, the blank time starts:

- Case 1: At expiration of the active cross-current protection (Figure 7), if the opposite MOSFET was previously activated.
- Case 2: Right after the decoding of the SPI command to turn on a MOSFET, if the half-bridge was in high impedance (Figure 8).

The blank times can be configured with the control registers `CCP_BLK2_ACT` and `PWM_ICHGMAX_CCP_BLK3_ACT` for the active MOSFETs and `CCP_BLK2_FW` and `PWM_ICHGMAX_CCP_BLK3_FW` for the freewheeling MOSFETs.

Table 19 Drain-source overvoltage blank time

TBLANKx[2:0], x = 1...4	Drain-Source overvoltage blank time tBLANKx, x = 1...4 (typical)
000 _B	625 ns
001 _B	1 μs
010 _B	1.25 μs
011 _B	1.5 μs
100 _B	2 μs (default)
101 _B	3 μs
110 _B	4 μs
111 _B	16 μs ¹⁾

1) When applying a blank time of 16 μs to a half-bridge, the max. drive current used for this half-bridge must be set below 30 mA, to avoid an overheating of the gate driver.

Note: The blank time is implemented at every new activation of a MOSFET, including a recovery from VS undervoltage, VS overvoltage.

6.5.3 Mapping of cross-current protection and blank times

One of the pairs of cross-current protection and blank times are mapped to each half-bridge according to [Table 20](#), by configuring the control register `CCP_BLK1`.

Table 20 Mapping of tCCP and tBLANK to the half-bridges

HBxCCPBLK[1:0], x =1..8	tCCP and tBLANK applied to HBx
00 _B	(tCCP1,tBLANK1) are mapped to HBx ¹⁾
01 _B	(tCCP2,tBLANK2) are mapped to HBx
10 _B	(tCCP3,tBLANK3) are mapped to HBx
11 _B	(tCCP4,tBLANK4) are mapped to HBx

1) Example: (tHBxCCP, tHBxBLANK) = (tCCP1, tBLANK1), x = 1 ... 4.

6.6 OFF-state diagnostic

In order to support the off-state diagnostic, the gate driver of each MOSFET provides pull-up (450 µA typ.) and a pull-down currents (1250 µA typ.) at the SHx pins when the driver driver is active (`BD_PASS = 0`). Under these conditions, the pull-up current sources are active.

Attention: *The off-state diagnostic is possible only when the bridge driver is active (`BD_PASS=0`) and the corresponding half-bridge is off (`HBxMODE = 00b or 11b`).*

The pull-down current of each gate driver are activated by the control bits HBxIDIAG (`HBIDIAG` register).

During the off-state diagnostic routine performed by the microcontroller, the drain-source overvoltage threshold of the relevant half-bridges must be set to 2 V nominal. Refer to [Table 16](#). Once the routine is finished, it is highly recommended to decrease the drain-source overvoltage threshold to a lower value, avoiding additional current consumption from the VS input.

The following failures can be detected:

- MOSFET short circuit to GND.
- MOSFET short circuit the battery.
- Open load (disconnected motor).

The status of the output voltages `VOUTx`, with $x = 1 \dots 8$, can be read back with status bit `HBxVOUT` (register `HBVOUT_PWMERR`) when the corresponding half-bridge is in off-state (`HBxMODE[1:0] = 00 or 11`).

Note: *HBxVOUT = 0 if the half-bridge x is not in off-state (`HBxMODE[1:0] = (0,1) or (1,0)`).*

Refer to [Application information, Chapter 9](#) for off-state diagnostic when the shunt resistor is in the motor phase.

6.7 Temperature monitoring

Temperature sensors are integrated in the device. The temperature monitoring circuit compares the measured temperature to the warning and shutdown thresholds.

Temperature warning

If the temperature sensor reaches T_{jW} , then **TW** is set (see **GENSTAT**). This bit is latched and reset by clearing **GENSTAT** if the thermal warning condition has disappeared. The outputs stages however remain activated. Refer to **Figure 36**.

Temperature shutdown

If the temperature sensor reaches T_{jSD} **all gate drivers are latched off, the charge pump is deactivated**; the SUPE bit (Supply Error bit, see **Global status byte**), **TSD** (Thermal Shutdown bit) and **CPUV** (Charge Pump Undervoltage) are set (see **GENSTAT**). All outputs remain deactivated until the temperature shutdown condition has disappeared and **GENSTAT** is cleared. See **Figure 36**.

The discharge current is according to the settings of **ST_ICHG**, as if the MOSFET was previously statically activated. To resume normal functionality of the gate drivers (in the event the overtemperature condition disappears, or to verify if the failure still exists) the microcontroller shall clear **GENSTAT**.

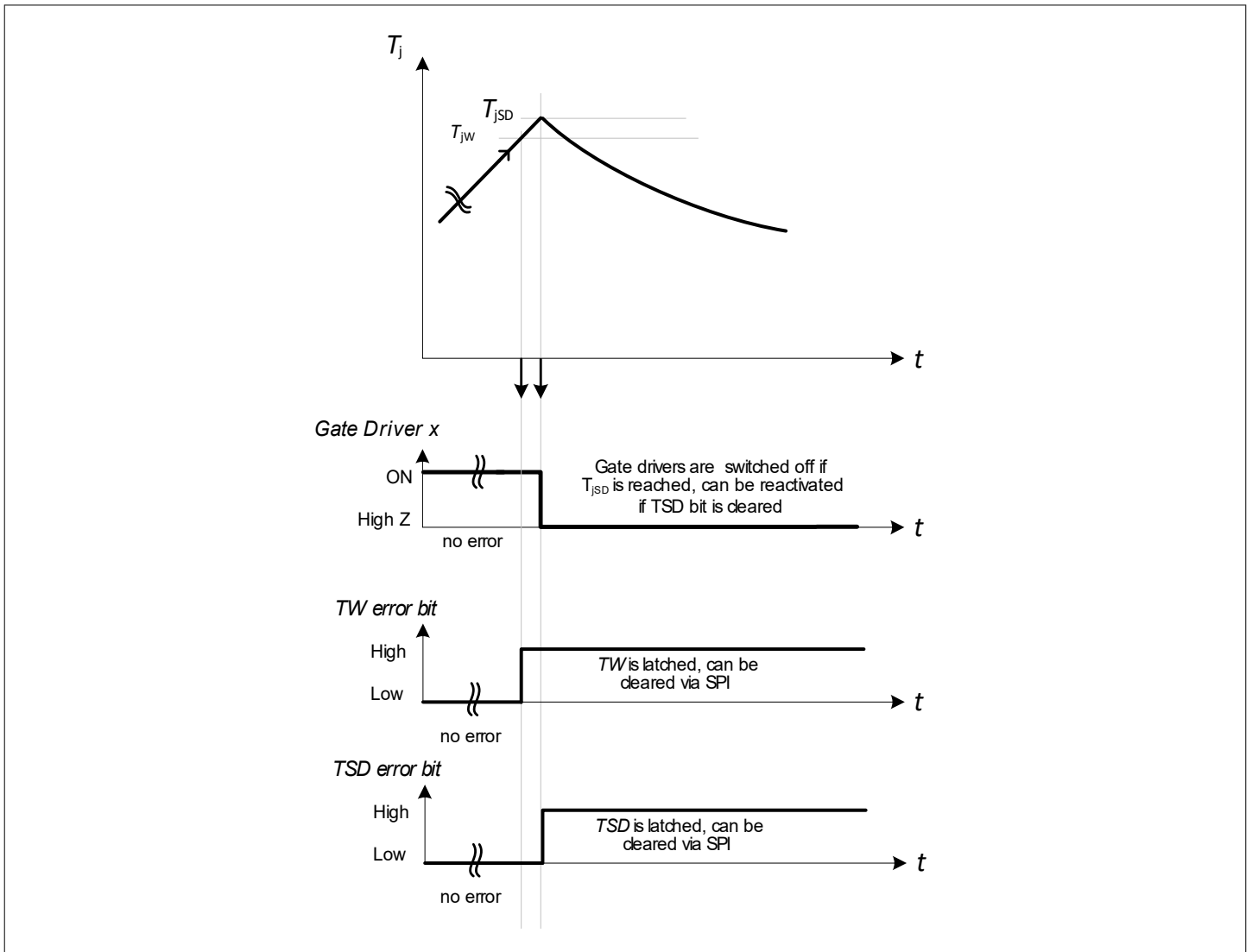

Figure 36 Overtemperature behavior

6.8 V_S overvoltage and undervoltage shutdown

The power supply rails V_S and V_{DD} are monitored for supply fluctuations. The V_S supply is monitored for under- and over-voltage conditions whereas the V_{DD} supply is monitored for under-voltage conditions.

6.8.1 V_S undervoltage

If V_S drops below $V_{SUV\ OFF}$, then all external MOSFETs are latched off, however, the logic information remains intact and uncorrupted provided that $V_{DD} > V_{DD\ POR}$.

SUPE (Supply Error bit, see [Global status byte](#)), [VSUV](#) and [CPUV](#) bits (see [GENSTAT](#)), are set and latched.

The [VSUV](#) bit is reset by clearing [GENSTAT](#) to re-enable the MOSFETs.

The [VSUV](#) bit is reset if the following conditions are fulfilled:

- $V_S > V_{SUV\ ON}$ (See [Figure 37](#)).
- The TLE92108-232QX receives a clear command to [GENSTAT](#).

6.8.2 V_S overvoltage with bridge driver in active mode

If V_S rises above the switch-off voltage ($V_{SOV\ OFF1}$ if $V_{SOVTH} = 0$, $V_{SOV\ OFF2}$ if $V_{SOVTH} = 1$) all external MOSFETs are latched off, and the charge pump is deactivated. SUPE bit (see [Global status byte](#)), [VSOV](#) bit (V_S over-voltage bit, see [GENSTAT](#)), and [CPUV](#) bit are set and latched. If V_S decreases below $V_{SOV\ ON}$, then the charge pump is reactivated automatically. The [VSOV](#) bit must be reset to re-enable the MOSFETs.

The [VSOV](#) bit is reset if the following conditions are fulfilled:

- $V_S < V_{SOV\ ON}$ (See [Figure 37](#)).
- The TLE92108-232QX receives a clear command to [GENSTAT](#).

The discharge current is according to the settings of [ST_ICHG](#), as if the MOSFET was previously statically activated.

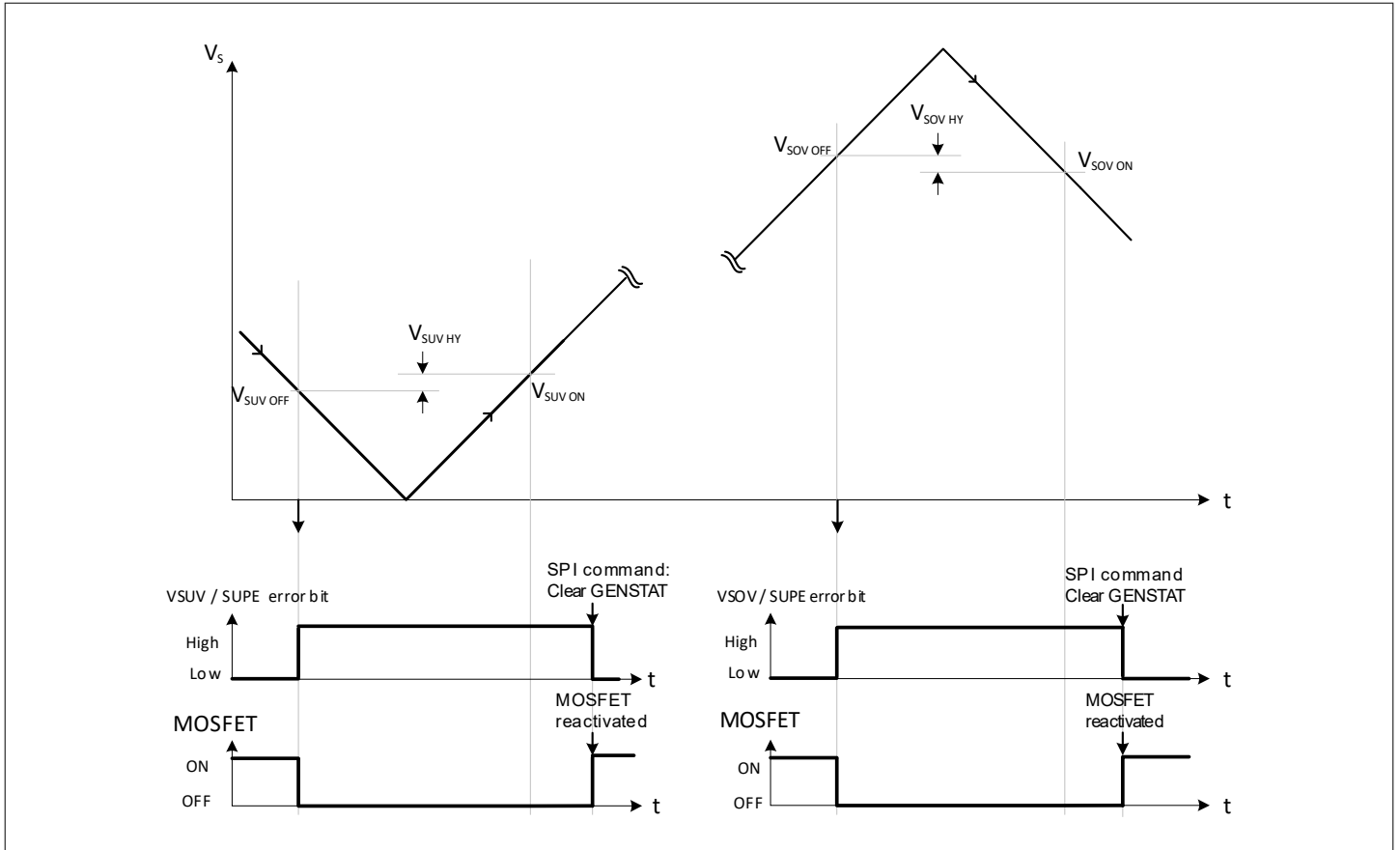

Figure 37 Output behavior during Over- and Undervoltage V_S condition

6.8.3 V_S overvoltage with bridge driver in passive mode

When the bridge driver is in passive mode (refer to Chapter 5.5):

- If $PASS_MOD[1:0] = 10_B$: LS1, LS2, LS3 and LS4 are turned on if $V_S > V_{SOV\ PASS\ OFF}$ (overvoltage brake). The PWM3 pin is pulled down by an internal open drain (RPWM3_OD).
- If $PASS_MOD[1:0] = 11_B$: LS1, LS2, LS3 and LS4 are turned on if $V_S > V_{SOV\ PASS\ OFF}$ and PWM1 = High (overvoltage brake conditioned upon PWM1). The PWM3 pin is pulled down by an internal open drain (RPWM3_OD).

6.8.4 V_{DD} undervoltage

If the V_{DD} logic supply decreases below the undervoltage threshold, $V_{DD\ POFFR}$, the SPI interface shall no longer be functional. The digital block will be reset and the gate drivers are switched off. The undervoltage reset is released once V_{DD} voltage is above the undervoltage threshold, $V_{DD\ POR}$.

6.8.5 Charge pump undervoltage

The voltage of the charge pump output (VCP) is monitored in order to ensure a correct control of the external MOSFETs.

If VCP falls below the configured charge pump undervoltage threshold:

- The external MOSFETs are actively discharged for the duration t_{HBxCCP} with the current I_{CHGSTx} , then the gate drivers are turned off.
- **CPUV** (GENSTAT), SUPE bits (Global status byte) and the Global Error Flag (Chapter 7.2) are set and latched.

The **CPUV** and SUPE bits are reset and the normal operation is resumed if **GENSTAT** is cleared, and $VCP > V_{CPUV}$.¹¹⁾

Notes:

1. A charge pump undervoltage event is reported after a power-on reset, when the charge time of the capacitor connected to VCP exceeds **tCPUV**.
2. The charge pump is deactivated after a VS undervoltage, a VS overvoltage and a thermal shutdown, causing a charge pump undervoltage condition. Consequently **CPUV** and **SUPE** bits are set together with **VSOV**, **VSUV** or **TSD** bits (see **GENSTAT**).

6.9 Switching parameters of MOSFETs in PWM mode

The effective switching parameters of the active MOSFETs (**EN_GEN_CHECK** =1) or of the PWM MOSFET (**EN_GEN_CHECK** =0) can be read out with dedicated status registers:

- The turn-on and turn off delays, noted **tDON** and **tDOFF**, are reported by the status register **EFF_TDON_OFF1**, **EFF_TDON_OFF2**, **EFF_TDON_OFF3**.
- The rise and fall times, noted **tRISE** and **tFALL**, are reported by the status register **TRISE_FALL1**, **TRISE_FALL2**, **TRISE_FALL3**.

Refer to [Chapter 5.3](#) for the definition of **tDON**, **tDOFF**, **tRISE** and **tFALL**.

If **tHBxBLANK** active has elapsed in motor mode, before the measurement of the effective **tDON**, the device reports an effective **tDON** corresponding to **tHBxBLANK** active.

If **tHBxCCP** active has elapsed while **EN_GEN_CHECK** =0¹²⁾, before the measurement of the effective **tDOFF**, the device reports an effective **tDOFF** corresponding to **tHBxCCP** active.

6.10 Timeout watchdog

An integrated timeout watchdog supervises the integrity of the communication with the microcontroller.

The watchdog period is programmable by the **WDPER** bit (refer to **GENCTRL1**).

After a Power-On Reset, the watchdog timer starts and the microcontroller must invert the logic value of the **WDTRIG** bit of the control register **GENCTRL1**. The default value of **WDTRIG** is 0. A correct trigger of the watchdog immediately resets the watchdog counter and starts the next cycle.

A watchdog failure is reported by the device if:

- The watchdog trigger bit is not served within the watchdog period (watchdog timeout event). See [Figure 38^{13\)}](#).
- The microcontroller writes the **WDTRIG** bit with the same value. In other words, if the **WDTRIG** value is 0 and the microcontroller re-writes **WDTRIG** to 0, or the **WDTRIG** is 1, and the microcontroller re-writes **WDTRIG** to 1, then a watchdog error is reported.

If a watchdog failure is detected, then the **FS** bit (see Global Status Byte) is set and latched, and the control registers are frozen to their default values. Consequently all external MOSFETs are actively turned off.

In order to resume normal operation, the microcontroller must: 1. clear **GENSTAT**. 2. Set **WDTRIG** to 1 within the watchdog period, 3. Set **WDTRIG** to 0 within the watchdog period¹⁴⁾.

The watchdog period is configurable by SPI to **TWDPER1** or **TWDPER2** (refer to **WDPER**).

¹¹ Recovering from VS under/overoltage and thermal shutdown, **CPUV** bit can be cleared only after 64 μ s

¹² If **EN_GEN_CHECK**= 1 and **tDOFF** cannot be measured until the expiration of **tHBxCCP**, then the device considers that the motor operate as generator

¹³ **WDMON[1:0]** (**GENSTAT**) is not reset after a WD timeout when the WD period is configured to 50 ms

¹⁴ The exit sequence must be strictly followed to leave fail safe mode. If a SPI frame not belonging to the sequence is added (incl. a read command), then the device stays in fail safe mode and the microcontroller must restart the complete sequence to enter normal mode.

Monitoring the watchdog timer

The status bits `WDMON[1:0]` report the relative position of the watchdog timer to the watchdog period. Refer to [Table 21](#) and [Figure 38](#). This allows the detection of a potential latent failure associated to the watchdog timer: the microcontroller can indeed verify that the watchdog timer is running.

Table 21 Monitoring of the watchdog timer

WDMON[1:0]	Position of the watchdog timer
00 _B	watchdog timer is between [0%, 25%[of the watchdog period
01 _B	watchdog timer is between [25%, 50%[of the watchdog period
10 _B	watchdog timer is between [50%, 75%[of the watchdog period
11 _B	watchdog timer is between [75%, 100%[of the watchdog period

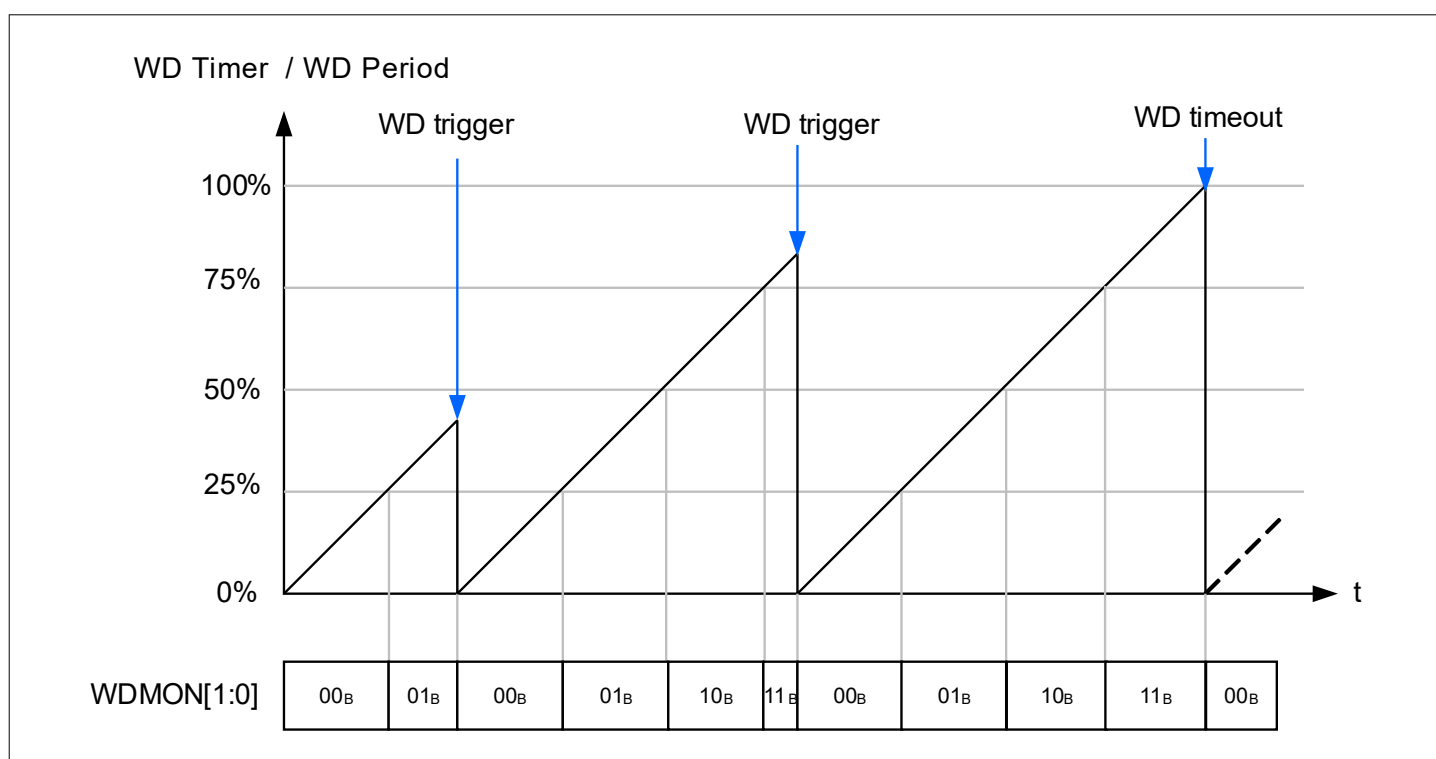

Figure 38 Example of watchdog monitoring and watchdog timeout

Disabling the watchdog

The watchdog is enabled by default.

It is disabled only if the following SPI sequence is sent:

- First frame: Set `UNLOCK` bit to '1' (`GENCTRL1`). Note: `UNLOCK` is automatically reset to '0' at the end of the following frame.
- Following frame: Set `WDDIS` bit to '1' (`GENCTRL2`).

The watchdog is directly re-enabled by setting `WDDIS` to '0'.

6.11 Current sense amplifier

Two current sense amplifiers allow to monitor the motor currents. The differential input stage measures the voltage drop across an external shunt resistor.

The input common mode range allows current sensing in high-side, in low-side configuration or in the motor phase.

6.11.1 Unidirectional and bidirectional operation

The current sense amplifiers (CSA) can work either as unidirectional or bi-directional CSA. See [CSD1](#) and [CSD2](#).

Unidirectional operation CSDx = 0

In unidirectional operation, the CSA_x, x = 1 or 2, is optimized to measure the current flowing through the external shunt resistor when $V_{CSIPx} \geq V_{CSINx}$.

$V_{CSOx} = V_{REF\ Unidir} + (V_{CSIPx} - V_{CSINx} + VOS) \times G_{DIFF}$, provided that V_{CSOx} is in the linear range^{15) 16)}.

Bidirectional operation CSDx = 1

In bidirectional operation, the CSA_x, x = 1 or 2, measures the current flowing through the external shunt resistor in both directions: $V_{CSIPx} \geq V_{CSINx}$ or $V_{CSIPx} \leq V_{CSINx}$.

The output CSO_x works at half-scale range: $V_{CSOx} = V_{REF\ Bidir} + (V_{CSIPx} - V_{CSINx} + VOS) \times G_{DIFF}$ provided that V_{CSOx} is in the linear range¹⁶⁾.

When the current sense amplifiers are deactivated (VS undervoltage, VS overvoltage, CP undervoltage or Overtemperature, or CSA_x_OFF = 1), CSO_x is pulled Low (between GND to 150 mV)

6.11.2 Gain configuration

The gain of the current sense amplifier is configurable by the configuration bits CSAG_x bits. Refer to [Table 22](#) and [GENCTRL1](#).

Table 22 Configuration of the current sense amplifier gain

CSAG _x [1:0]	Typical current sense amplifier gain G_{DIFF}
00 _B	10 V/V
01 _B	20 V/V
10 _B	40 V/V
11 _B	80 V/V

6.11.3 High-side and low-side setting

The CSA can be used either in high-side configuration or in low-side configuration within the specified common mode range.

The control bits CSA1L and CSA2L ([HBIDIAG](#)) optimize the VDD current consumption by informing the device about the common mode voltage of the CSA inputs:

- CSA_xL must be set to 0 if the shunt is in low-side configuration (i.e. connected to GND or to an output with an activated low-side).
- CSA_xL must be set to 1 if the shunt is in high-side configuration (i.e. connected to VS or to an output with an activated high-side).

Notes:

1. A proper information from the CSA output is not ensured if the external shunt resistor is in high-side configuration while its CSA_xL bit is set to 0.
2. The external shunt resistor may be in low-side configuration while its CSA_xL bit is set to 1. The current consumption from VDD is however higher than if CSA_xL is set to 0.

¹⁵ Valid if $0.5\text{ V} \leq V_{CSOx} \leq V_{DD} - 0.5\text{ V}$.

¹⁶ VCSO_x is clamped between VDD and GND.

6.11.4 Overcurrent detection

A comparator at CS0x detects overcurrent conditions. The overcurrent threshold is configurable with the OCTHx bits. Refer to [Table 23](#) for unidirectional operation and [Table 24](#) for bidirectional operation.

Table 23 Overcurrent detection thresholds in unidirectional operation (CSDx = 0)

OCTHx[1:0]	Typical Overcurrent Detection Threshold
00 _B	$V_{CS0x} > V_{DD}/2$
01 _B	$V_{CS0x} > V_{DD}/2 + V_{DD}/10$
10 _B	$V_{CS0x} > V_{DD}/2 + 2 \times V_{DD}/10$
11 _B	$V_{CS0x} > V_{DD}/2 + 3 \times V_{DD}/10$

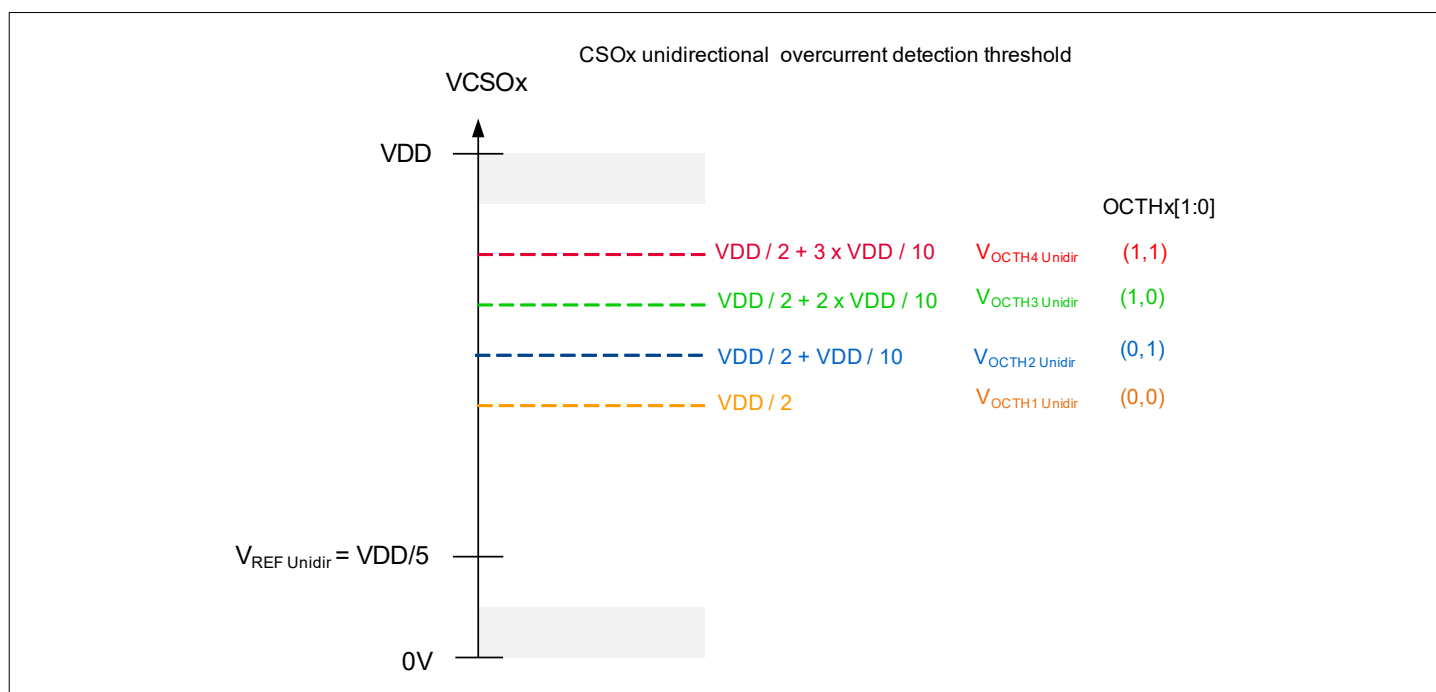

Figure 39 Overcurrent detection thresholds in unidirectional operation (CSDx = 0)

Table 24 Overcurrent detection thresholds in bidirectional operation (CSDx = 1)

OCTHx[1:0]	Typical Overcurrent Detection Threshold
00 _B	$V_{CS0x} > V_{DD}/2 + 2 \times V_{DD}/20$ or $V_{CS0x} < V_{DD}/2 - 2 \times V_{DD}/20$
01 _B	$V_{CS0x} > V_{DD}/2 + 4 \times V_{DD}/20$ or $V_{CS0x} < V_{DD}/2 - 4 \times V_{DD}/20$
10 _B	$V_{CS0x} > V_{DD}/2 + 5 \times V_{DD}/20$ or $V_{CS0x} < V_{DD}/2 - 5 \times V_{DD}/20$
11 _B	$V_{CS0x} > V_{DD}/2 + 6 \times V_{DD}/20$ or $V_{CS0x} < V_{DD}/2 - 6 \times V_{DD}/20$

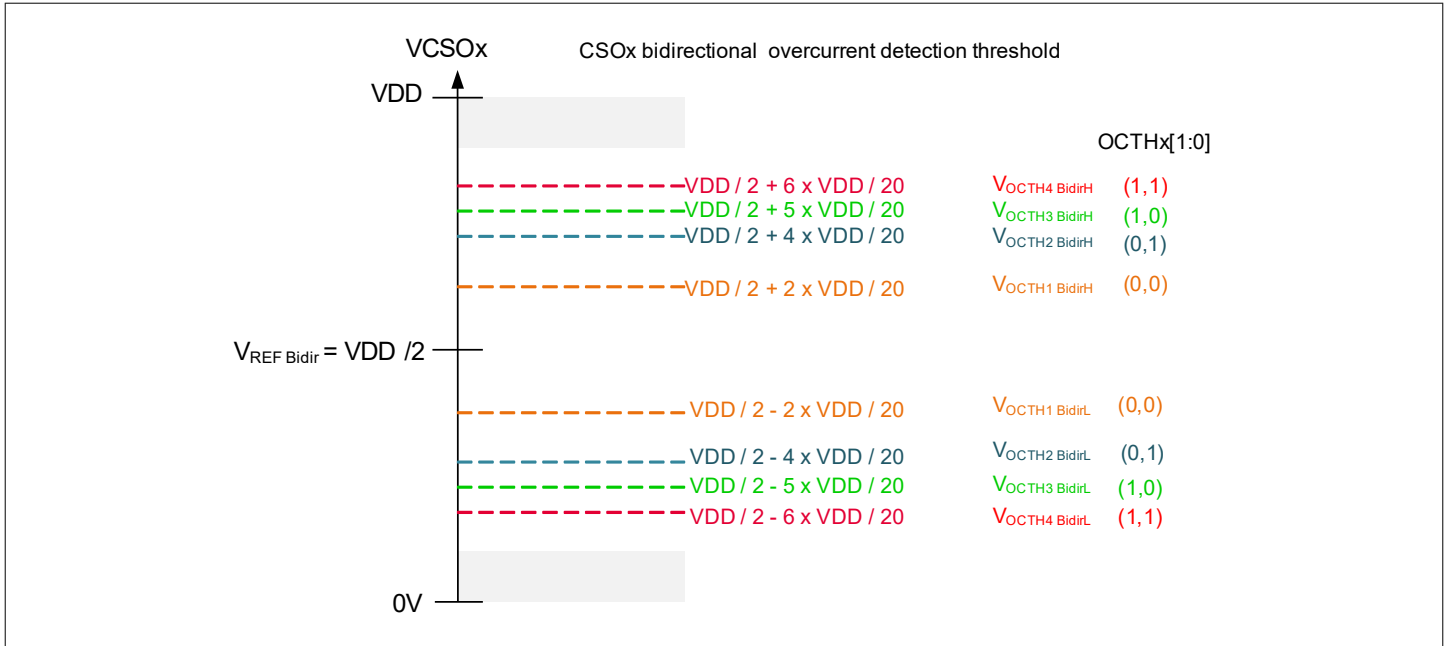

Figure 40 Overcurrent detection thresholds in bidirectional operation (CSDx = 1)

It is possible to program the device behavior when an overcurrent condition is detected:

- OCEN bit = 0 (see [GENCTRL1](#)): the device only reports the overcurrent event (OC, OC1 or OC2 in [GENSTAT](#) and Global Error Flag are set), without any change of the gate driver states
 - If the overcurrent condition is not present for more than t_{FOC} , then the overcurrent status bits are automatically cleared by the device.
- OCEN bit = 1 (see [GENCTRL1](#)): the device reports the overcurrent event (OC, OC1 or OC2 in [GENSTAT](#) and Global Error Flag are set) and turns off all MOSFETs with their static discharge current.
 - The MOSFETs can be reactivated by clearing [GENSTAT](#) or by resetting the OCEN bit.
 - The overcurrent status bits are reset only if the overcurrent condition is no longer present and the microcontroller clears [GENSTAT](#).

The overcurrent filter time is configurable (refer to t_{FOC}) by the control bits OCxFILT (refer to [HBIDIAG](#)).

t_{FOC} refers to the output of the current sense amplifier. The CSO settling time ($2 \mu s$ max, t_{SET}) and the analog propagation delay ($< 1 \mu s$) are not taken into account by the overcurrent filter time.

6.11.5 CSO outputs capacitor

The capacitor directly connected to CSOx (CCSOx) must be between 10 pF and 400 pF (refer to [Chapter 9](#)).

The control bit CCSO (see [PWM_IDCHG_ACT](#), [PWM_PDCHG_INIT](#)) optimizes the VDD current consumption for CCSOx < 100 pF or CCSOx > 100 pF.

6.12 Electrical characteristics protections and diagnostics

The specified drain-source monitoring thresholds, the overcurrent thresholds and the electrical characteristics related to the current sense amplifiers are valid for $V_{CP} > V_S + 8\text{ V}$

Table 25 Electrical characteristics:

$V_S = 6.0\text{ V}$ to 18 V if $V_{SOVTH} = 0$, $V_S = 6.0\text{ V}$ to 28 V if $V_{SOVTH} = 1$; $V_{DD} = 3.0\text{ V}$ to 5.5 V , $T_j = -40^\circ\text{C}$ to 150°C

$V_{CP} > V_S + 8\text{ V}$

All voltages with respect to ground, positive current flowing into pin (unless otherwise specified)

Parameter	Symbol	Values			Unit	Note or Test Condition	Number
		Min.	Typ.	Max.			
Watchdog							
Watchdog period 1	T_{WDPER1}	40	50	60	ms	¹⁾ $WDPER = 0$	P_7.11.52
Watchdog period 2	T_{WDPER2}	160	200	240	ms	¹⁾ $WDPER = 1$	P_7.11.53
Off-state Open load diagnosis							
Pull-up diagnosis current	I_{PUDiag}	-630	-450	-270	μA	¹⁾	P_7.11.1
Pull-down diagnosis current	I_{PDDiag}	900	1250	1600	μA	¹⁾	P_7.11.2
Diagnosis current ratio	I_{Diag_ratio}	2.5	3.0	-		Ratio I_{PDDiag} / I_{PUDiag}	P_7.11.77
Drain source monitoring threshold							
Drain-source monitoring thresholds	$V_{VDSMONTH0}$	0.12	0.15	0.18	V	$HBxVDSTH[2:0] = 000_B$	P_7.11.3
Drain-source monitoring thresholds	$V_{VDSMONTH1}$	0.16	0.20	0.24	V	$HBxVDSTH[2:0] = 001_B$	P_7.11.4
Drain-source monitoring thresholds	$V_{VDSMONTH2}$	0.20	0.25	0.30	V	$HBxVDSTH[2:0] = 010_B$	P_7.11.5
Drain-source monitoring thresholds	$V_{VDSMONTH3}$	0.24	0.30	0.36	V	$HBxVDSTH[2:0] = 011_B$	P_7.11.6
Drain-source monitoring thresholds	$V_{VDSMONTH4}$	0.32	0.40	0.48	V	$HBxVDSTH[2:0] = 100_B$	P_7.11.7
Drain-source monitoring thresholds	$V_{VDSMONTH5}$	0.40	0.50	0.62	V	$HBxVDSTH[2:0] = 101_B$	P_7.11.8
Drain-source monitoring thresholds	$V_{VDSMONTH6}$	0.48	0.60	0.72	V	$HBxVDSTH[2:0] = 110_B$	P_7.11.9
Drain-source monitoring thresholds	$V_{VDSMONTH7}$	1.6	2.0	2.4	V	$HBxVDSTH[2:0] = 111_B$	P_7.11.54
Drain-source monitoring blank time							
DS monitoring blank time	t_{DSMON_BLK0}	500	625	850	ns	$TBLANKx[2:0] = 000_B$ ¹⁾	P_7.11.10
DS monitoring blank time	t_{DSMON_BLK1}	0.8	1	1.2	μs	$TBLANKx[2:0] = 001_B$ ¹⁾	P_7.11.11

(table continues...)

Table 25 (continued) Electrical characteristics:

$V_S = 6.0\text{ V to }18\text{ V}$ if $V_{SOVTH} = 0$, $V_S = 6.0\text{ V to }28\text{ V}$ if $V_{SOVTH} = 1$; $V_{DD} = 3.0\text{ V to }5.5\text{ V}$, $T_j = -40^\circ\text{C to }150^\circ\text{C}$

$V_{CP} > V_S + 8\text{ V}$

All voltages with respect to ground, positive current flowing into pin (unless otherwise specified)

Parameter	Symbol	Values			Unit	Note or Test Condition	Number
		Min.	Typ.	Max.			
DS monitoring blank time	t_{DSMON_BLK2}	1	1.25	1.5	μs	TBLANKx[2:0] = 010 _B ¹⁾	P_7.11.12
DS monitoring blank time	t_{DSMON_BLK3}	1.2	1.5	1.8	μs	TBLANKx[2:0] = 011 _B ¹⁾	P_7.11.13
DS monitoring blank time	t_{DSMON_BLK4}	1.6	2	2.4	μs	TBLANKx[2:0] = 100 _B ¹⁾	P_7.11.57
DS monitoring blank time	t_{DSMON_BLK5}	2.4	3	3.6	μs	TBLANKx[2:0] = 101 _B ¹⁾	P_7.11.58
DS monitoring blank time	t_{DSMON_BLK6}	3.2	4	4.8	μs	TBLANKx[2:0] = 110 _B ¹⁾	P_7.11.59
DS monitoring blank time	t_{DSMON_BLK7}	12.8	16	19.2	μs	TBLANKx[2:0] = 111 _B ¹⁾	P_7.11.60

Drain-source monitoring filter time

DS monitoring filter time	t_{DSMON_FILT0}	0.4	0.5	0.85	μs	TFVDS[1:0] = 00 _B ¹⁾	P_7.11.14
DS monitoring filter time	t_{DSMON_FILT1}	0.8	1	1.4	μs	TFVDS[1:0] = 01 _B ¹⁾	P_7.11.15
DS monitoring filter time	t_{DSMON_FILT2}	1.6	2	2.4	μs	TFVDS[1:0] = 10 _B ¹⁾	P_7.11.16
DS monitoring filter time	t_{DSMON_FILT3}	2.4	3	3.6	μs	TFVDS[1:0] = 11 _B ¹⁾	P_7.11.17

Cross-current protection time

Cross current protection time	$t_{HBxCCP0}$	300	375	450	ns	THBxCCP[2:0] = 000 _B ¹⁾	P_7.11.18
Cross current protection time	$t_{HBxCCP1}$	500	625	750	ns	THBxCCP[2:0] = 001 _B ¹⁾	P_7.11.19
Cross current protection time	$t_{HBxCCP2}$	0.8	1	1.2	μs	THBxCCP[2:0] = 010 _B ¹⁾	P_7.11.20
Cross current protection time	$t_{HBxCCP3}$	1.2	1.5	1.8	μs	THBxCCP[2:0] = 011 _B ¹⁾	P_7.11.21
Cross current protection time	$t_{HBxCCP4}$	1.6	2	2.4	μs	THBxCCP[2:0] = 100 _B ¹⁾	P_7.11.22
Cross current protection time	$t_{HBxCCP5}$	2.4	3	3.6	μs	THBxCCP[2:0] = 101 _B ¹⁾	P_7.11.23
Cross current protection time	$t_{HBxCCP6}$	3.2	4	4.8	μs	THBxCCP[2:0] = 110 _B ¹⁾	P_7.11.24
Cross current protection time	$t_{HBxCCP7}$	12.8	16	19.2	μs	THBxCCP[2:0] = 111 _B ¹⁾	P_7.11.25

(table continues...)

Table 25 (continued) Electrical characteristics:

$V_S = 6.0\text{ V to }18\text{ V}$ if $V_{SOVTH} = 0$, $V_S = 6.0\text{ V to }28\text{ V}$ if $V_{SOVTH} = 1$; $V_{DD} = 3.0\text{ V to }5.5\text{ V}$, $T_j = -40^\circ\text{C to }150^\circ\text{C}$

$V_{CP} > V_S + 8\text{ V}$

All voltages with respect to ground, positive current flowing into pin (unless otherwise specified)

Parameter	Symbol	Values			Unit	Note or Test Condition	Number
		Min.	Typ.	Max.			
Bridge driver passive mode: $BD_PASS = 1$ and all $HBxMODE[1:0] = 00_B$ or 11_B, or $EN = \text{Low}$ or $V_{DD} < V_{DDPOR}$							
Passive V_S overvoltage	$V_{SOVPASSOFF}$	28	31.5	35	V	V_S increasing $PASS_MOD=10_B$	P_7.11.66
Passive V_S overvoltage hysteresis	$V_{SOVPASSHY}$	1	2.5	4	V	¹⁾	P_7.11.67
PWM3 open drain resistance	R_{PWM3_OD}	4	5.5	7	k Ω		P_7.11.68
Passive turn-on time	$t_{ON_BD_PASS}$	-	4.5	10	μs	¹⁾ Cap = 10 nF, VCap = 5 V, $V_S > 8\text{ V}$	P_7.11.69
Passive Turn-off time	$t_{OFF_BD_PASS}$	-	0.7	3.2	μs	¹⁾ Cap = 10 nF, VCap down to 1.5 V, $V_S > 8\text{ V}$	P_7.11.70
Passive LS gate voltage	V_{GLX_BRAKE}	5	-	10	V	$V_{GLX} - V_{SL}$, $x = 1 \text{ to } 4$, $V_S > 8\text{ V}$	P_7.11.71
Passive turn-on blank time	$t_{BLK_BD_PASS}$	2	6	10	μs	¹⁾	P_7.11.72
PWM1 high voltage, bridge driver passive	$V_{PWM1H_BD_PASS}$	0.5	1.3	2.0	V		P_7.11.73
Passive VDS filter time	$t_{DSMON_FILT_BD_PASS}$	0.5	1	2	μs	¹⁾	P_7.11.74
Passive drain-source monitoring thresholds	$V_{VDSMON_BD_PASS}$	0.30	0.37	0.44	V	$PASS_VDS=1_B$	P_7.11.75

Current sense amplifier

Operating common mode input voltage range referred to GND (CSIPx - GND) or (CSINx - GND)	V_{CM}	-2.0	-	28	V		P_7.11.26
Common Mode Rejection Ratio	CMRR	69 75 81 81	- - - -	- - - -	dB	CSAG = (0,0) CSAG = (0,1) CSAG = (1,0) CSAG = (1,1) DC to 50 kHz $V_{CM} = -2 \dots 28\text{ V}$ ¹⁾ $V_{CSIPx} = V_{CSINx}$	P_7.11.27
Settling time to 98%	t_{SET}	-	1500	2000	ns	¹⁾	P_7.11.28

(table continues...)

Table 25 (continued) Electrical characteristics:

$V_S = 6.0\text{ V to }18\text{ V}$ if $V_{SOVTH} = 0$, $V_S = 6.0\text{ V to }28\text{ V}$ if $V_{SOVTH} = 1$; $V_{DD} = 3.0\text{ V to }5.5\text{ V}$, $T_j = -40^\circ\text{C to }150^\circ\text{C}$

$V_{CP} > V_S + 8\text{ V}$

All voltages with respect to ground, positive current flowing into pin (unless otherwise specified)

Parameter	Symbol	Values			Unit	Note or Test Condition	Number
		Min.	Typ.	Max.			
Settling time to 98% after gain change	t_{SET_GAIN}	–	–	5000	ns	¹⁾ After gain change from CSN rising edge	P_7.11.65
Input Offset voltage	V_{OS}	-1.5	0	1.5	mV		P_7.11.29
Current Sense Amplifier DC Gain (uncalibrated)	G_{DIFF10}	9.9	10	10.1	V/V	CSAG = (0,0)	P_7.11.30
Current Sense Amplifier DC Gain (uncalibrated)	G_{DIFF20}	19.8	20	20.2	V/V	CSAG = (0,1)	P_7.11.31
Current Sense Amplifier DC Gain (uncalibrated)	G_{DIFF40}	39.6	40	40.4	V/V	CSAG = (1,0)	P_7.11.32
Current Sense Amplifier DC Gain (uncalibrated)	G_{DIFF80}	79.2	80	80.8	V/V	CSAG = (1,1)	P_7.11.33
Gain drift	G_{DRIFT}	-0.5	–	0.5	%	¹⁾ Gain drift after calibration	P_7.11.34
CSOx single ended output voltage range (linear range)	V_{CSOX}	0.5	–	$V_{DD} - 0.5$	V	¹⁾	P_7.11.35
Reference voltage for unidirectional CSAx	$V_{REF\ Unidir}$	-1%	$V_{DD} / 5$	+1%	V	CSDx = 0 $V_{CSIPx} = V_{CSINx}$	P_7.11.36
Reference voltage for bidirectional CSAx	$V_{REF\ Bidir}$	-1%	$V_{DD} / 2$	+1%	V	CSDx = 1 $V_{CSIPx} = V_{CSINx}$	P_7.11.37

Overcurrent detection

Overcurrent filter time	t_{FOC}	4	6	8	μs	OCxFILT = 00 _B OCxFILT = 01 _B OCxFILT = 10 _B OCxFILT = 11 _B ^{1) 2)}	P_7.11.38
		7	10	13			
		40	50	60			
		85	100	115			
OC threshold, unidirectional	$V_{OCTH1\ Unidir}$	-4%	$V_{DD} / 2$	+4%	V	CSDx = 0, OCTH[1:0] = 00 _B	P_7.11.39
OC threshold, unidirectional	$V_{OCTH2\ Unidir}$	-4%	$V_{DD} / 2 + V_{DD} / 10$	+4%	V	CSDx = 0, OCTH[1:0] = 01 _B	P_7.11.40
OC threshold, unidirectional	$V_{OCTH3\ Unidir}$	-4%	$V_{DD} / 2 + 2x V_{DD} / 10$	+4%	V	CSDx = 0, OCTH[1:0] = 10 _B	P_7.11.41

(table continues...)

Table 25 (continued) Electrical characteristics:

$V_S = 6.0\text{ V to }18\text{ V}$ if $V_{SOVTH} = 0$, $V_S = 6.0\text{ V to }28\text{ V}$ if $V_{SOVTH} = 1$; $V_{DD} = 3.0\text{ V to }5.5\text{ V}$, $T_j = -40^\circ\text{C to }150^\circ\text{C}$

$V_{CP} > V_S + 8\text{ V}$

All voltages with respect to ground, positive current flowing into pin (unless otherwise specified)

Parameter	Symbol	Values			Unit	Note or Test Condition	Number
		Min.	Typ.	Max.			
OC threshold, unidirectional	$V_{OCTH4\text{ Unidir}}$	-4%	$V_{DD}/2 + 3X$ $V_{DD}/10$	+4%	V	CSDx = 0, OCTH[1:0] = 11 _B	P_7.11.42
High OC threshold, bidirectional	$V_{OCTH1\text{ BidirH}}$	-4%	$V_{DD}/2 + 2X$ $V_{DD}/20$	+4%	V	CSDx = 1, OCTH[1:0] = 00 _B	P_7.11.43
High OC threshold, bidirectional	$V_{OCTH2\text{ BidirH}}$	-4%	$V_{DD}/2 + 4X$ $V_{DD}/20$	+4%	V	CSDx = 1, OCTH[1:0] = 01 _B	P_7.11.44
High OC threshold, bidirectional	$V_{OCTH3\text{ BidirH}}$	-4%	$V_{DD}/2 + 5X$ $V_{DD}/20$	+4%	V	CSDx = 1, OCTH[1:0] = 10 _B	P_7.11.45
High OC threshold, bidirectional	$V_{OCTH4\text{ BidirH}}$	-4%	$V_{DD}/2 + 6X$ $V_{DD}/20$	+4%	V	CSDx = 1, OCTH[1:0] = 11 _B	P_7.11.46
Low OC threshold, bidirectional	$V_{OCTH1\text{ BidirL}}$	-4%	$V_{DD}/2 - 2X$ $V_{DD}/20$	+4%	V	CSDx = 1, OCTH[1:0] = 00 _B	P_7.11.61
Low OC threshold, bidirectional	$V_{OCTH2\text{ BidirL}}$	-4%	$V_{DD}/2 - 4X$ $V_{DD}/20$	+4%	V	CSDx = 1, OCTH[1:0] = 01 _B	P_7.11.62
Low OC threshold, bidirectional	$V_{OCTH3\text{ BidirL}}$	-4%	$V_{DD}/2 - 5X$ $V_{DD}/20$	+4%	V	CSDx = 1, OCTH[1:0] = 10 _B	P_7.11.63
Low OC threshold, bidirectional	$V_{OCTH4\text{ BidirL}}$	-4%	$V_{DD}/2 - 6X$ $V_{DD}/20$	+4%	V	CSDx = 1, OCTH[1:0] = 11 _B	P_7.11.64

Thermal warning and shutdown

Thermal warning junction temperature	T_{jw}	120	140	160	°C	See Figure 36 ¹⁾	P_7.11.48
Thermal shutdown junction temperature	T_{jSD}	160	180	200	°C	See Figure 36 ¹⁾	P_7.11.49
Thermal shutdown hysteresis	T_{jHYS}	–	10	–	°C	¹⁾	P_7.11.50
Ratio of T_{jSD} to T_{jw}	T_{jSD}/T_{jw}	–	1.20	–	–	¹⁾	P_7.11.51
Thermal warning filter time	t_{jw_FILT}	7	10	13	µs	¹⁾	P_7.11.55
Thermal shutdown filter time	t_{jSD_FILT}	7	10	13	µs	¹⁾	P_7.11.56

¹⁾ Not subject to production test, specified by design.

- 2) t_{FOC} refers to the output of the current sense amplifier. The CSO settling time ($2 \mu\text{s max, } t_{SET}$) and the analog propagation delay ($< 1 \mu\text{s}$) are not taken into account by the overcurrent filter time.
-

7 Serial Peripheral Interface - SPI

The 24-bit Serial Peripheral Interface (SPI) enables the communication between the microcontroller and the TLE92108-232QX. It allows to configure and control the device, and to read out the status registers for diagnostic purpose. The MOSFET driver IC acts as a SPI-slave while the microcontroller acts as a SPI-master.

The interface has a serial data input pin (SDI) to transfer data to the device, a serial data output pin (SDO) for reading data back from the device, and a serial clock pin (SCLK) for clocking data into and out of the device. A chip select pin (CSN) enables or disables the serial interface.

The SPI frame starts with the falling edge of CSN. During the falling edge of CSN, SCLK must be low (Clock Polarity CPOL = 0). Received data on SDI are shifted in on the falling edge of SCLK. Transmitted data by SDO are shifted out on the rising edge of SCLK (Clock Phase CPHA = 1). Refer to [Figure 42](#).

The Most Significant Bit (MSB, bit 23) is shifted in/out first.

Write and clear commands are executed at the rising edge of CSN.

The SPI protocol supports both independent slave selection and daisy chain configurations.

7.1 SPI protocol with independent slave selection

With individual slave selection, the microcontroller controls the CSN pin of each SPI slave individually ([Figure 41](#)).

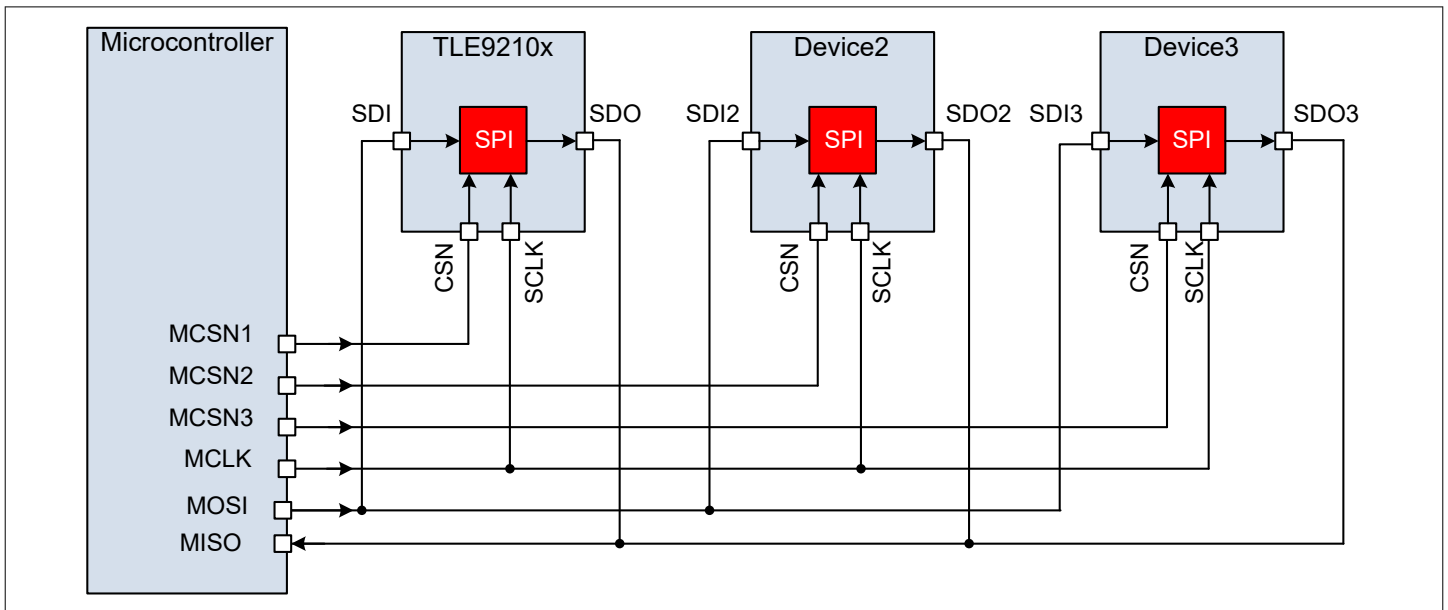

Figure 41 Individual slave selection with three slave devices

A SPI communication consists of 24-bit frame ([Figure 42](#)):

- SDI receives one address byte followed by two data bytes.
- SDO transmits the Global Error Flag and the Global Status Byte followed by two response bytes.

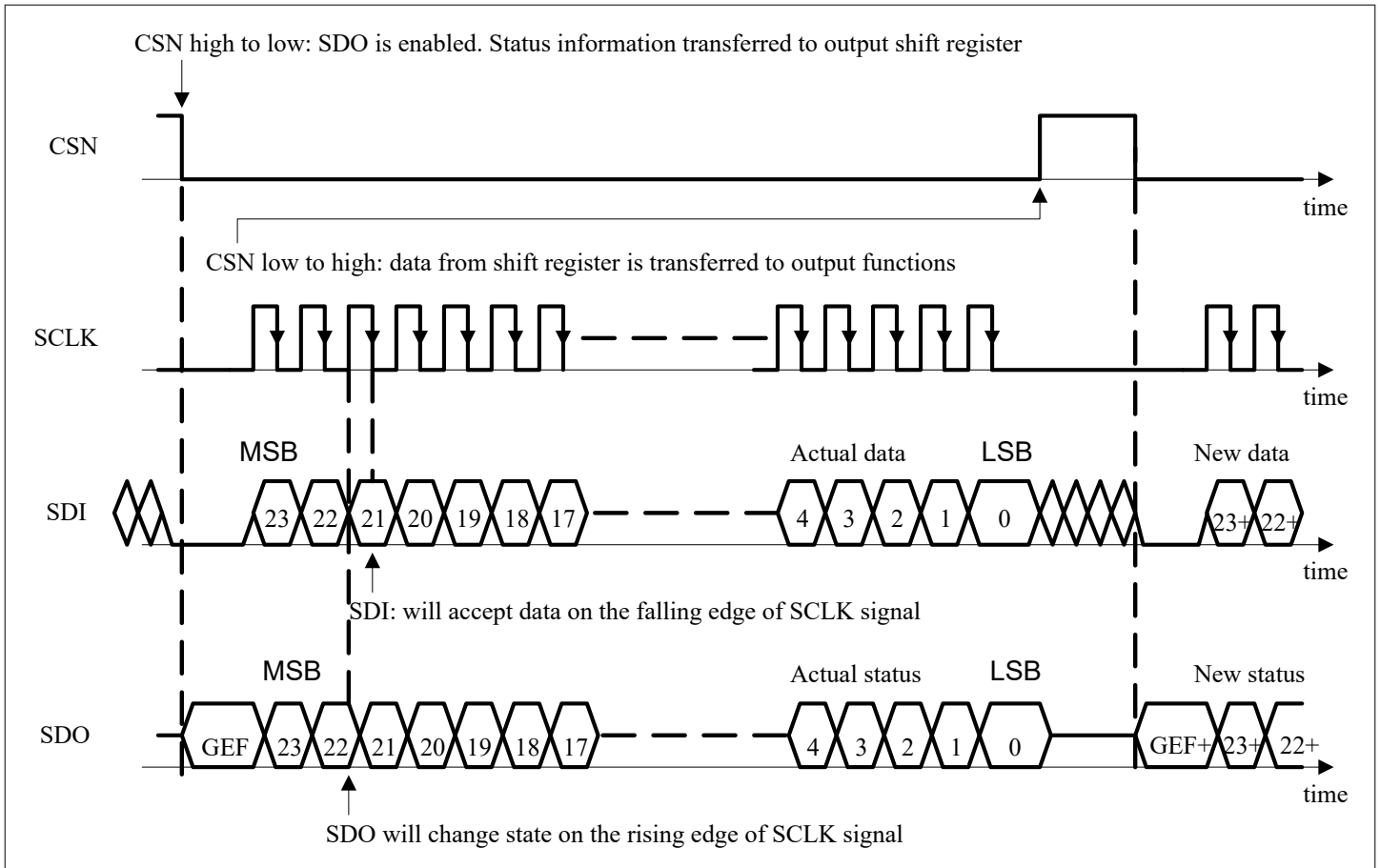

Figure 42 SPI Data Transfer

The MSB of the address byte must be set to '1'.

The address byte specifies (see [Figure 43](#)):

- the target register (A[4:0])
- the type of operation:
 - For control registers:
 - Read only: OP bit¹⁷ = '0'
 - Read and write: OP bit = '1'
 - For status registers:
 - Read only: OP bit = '0'
 - Read and clear: OP bit = '1'

With individual slave selection, the Last Address Byte Token (LABT) must be set to '1'.

In-frame response

The SPI protocol incorporates an in-frame response: The content of the addressed register is shifted out by SDO within the same SPI frame. This feature reduces the SPI bus load during the read out of the control or status registers.

¹⁷ OP bit is the least significant bit of the address byte, see [Figure 43](#)

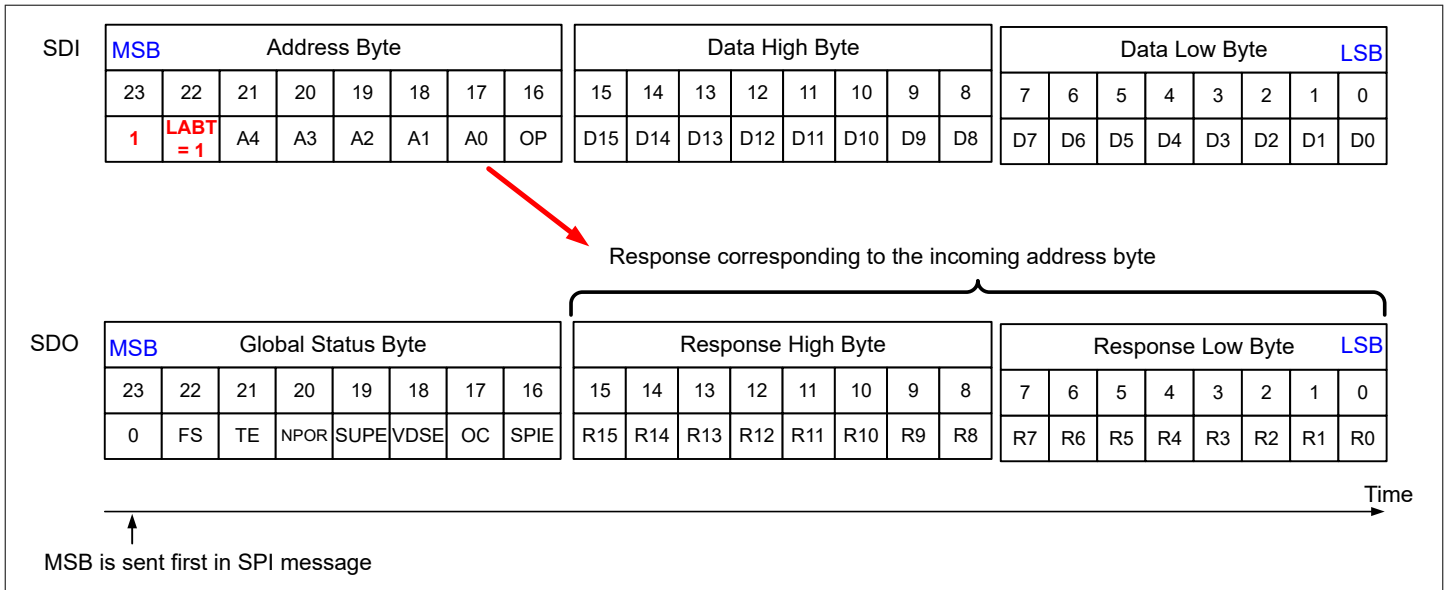

Figure 43 In-frame response with individual slave selection

7.2 Global Error Flag (GEF)

The Global Error Flag (GEF) is reported on SDO between the CSN falling edge and the first SCLK rising edge. GEF is set if a fault condition is detected or if the device comes from a Power On Reset (POR). It is therefore possible to have a quick device diagnostic without any SPI clock pulse (Figure 44).

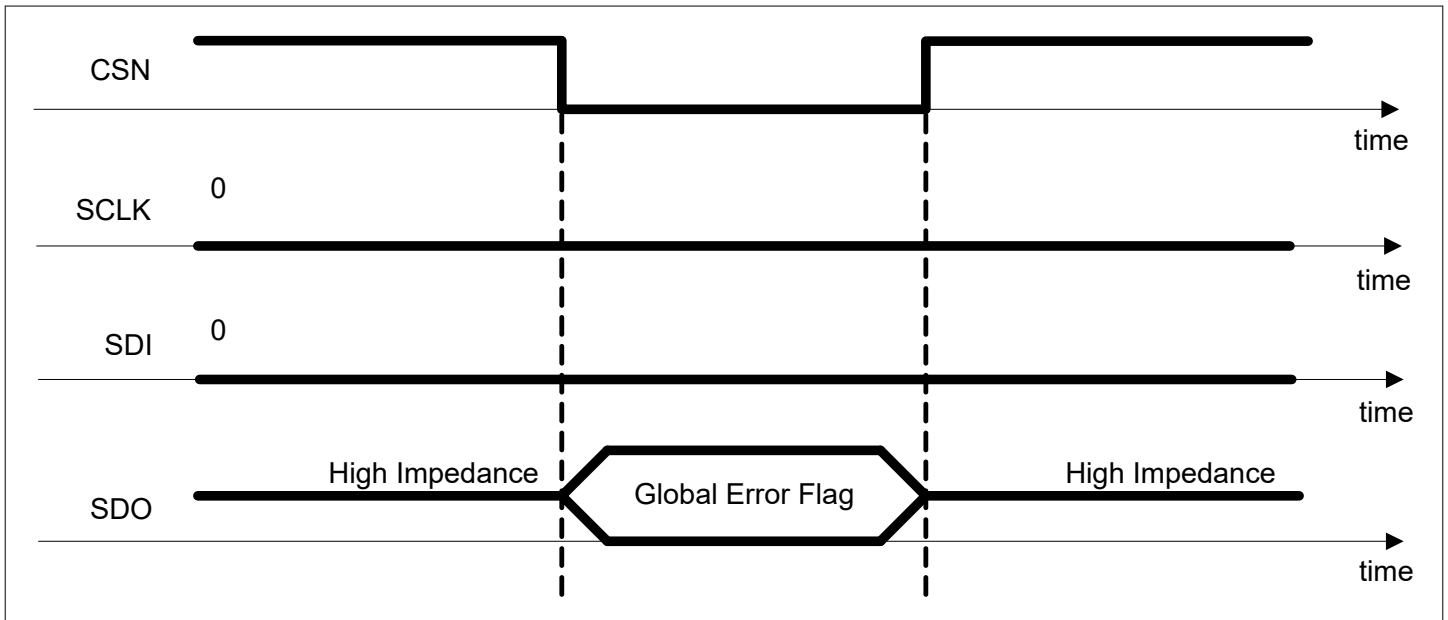

Figure 44 GEF - Diagnostic with 0-clock cycle

7.3 Global status byte

The SDO shifts out during the first eight SCLK cycles the Global Status Byte. This register provides an overview of the device status. The following error conditions are reported in this byte:

- Fail Safe (FS bit).
- Temperature error (TE bit): logical OR combination between Thermal Warning (TW) and Thermal shutdown (TSD).
- **Negated** Power ON Reset (NPOR bit, refer to Chapter 4.3 for reset conditions).

- Supply Error (SUPE bit): logical OR combination between VS undervoltage shutdown (VSUV), VS overvoltage shutdown (VSOV) and charge pump undervoltage (CPUV).
- VDS monitoring Error (VDSE bit): logical OR combination between the bits of the DSOV register.
- Overcurrent (OC bit): logical OR combination between OC1 and OC2 status bits (GENSTAT register).
- SPI protocol Error (SPIE bit).

Note: The Global Error Flag is a logic OR combination of every bit of the Global Status Byte and of TDREGx:
 $GEF = (FS) \text{ OR } (TE) \text{ OR } (\text{NOT}(\text{NPOR})) \text{ OR } (SUPE) \text{ OR } (VDSE)$
OR (OC)
OR (SPIE) OR ($\text{NOT}(\text{TDREG}_x) \text{ AND } (\text{PWM}_x_EN = 1) \text{ AND } (\text{NOT}(\text{MSKTDREG}))$), $x = 1 \dots 3$.

The following table shows how failures are reported in the Global Status Byte and the error Flag:

Table 26 Failure reported in the global status byte and global error flag

Type of Error	Failure reported in the Global Status Byte	Global Error Flag
Fail safe	FS = 1	1
Thermal error	TE = 1	1
Power ON reset	NPOR = 0	1
Supply error	SUPE = 1	1
Drain source voltage monitoring	VDSE = 1	1
Overcurrent	OC = 1	1
SPI protocol error	SPIE = 1	1
TDREGx, $x = 1 \dots 3$ ¹⁾ (see GENSTAT)	-	1 if MSKTDREG = 0 ²⁾ 0 if MSKTDREG = 1 ²⁾
No error and no power ON reset	SPIE = 0 OC = 0 VDSE = 0 SUPE = 0 NPOR = 1 TE = 0 FS = 0 TDREGx = 0,	0

1) See status register GENSTAT.

2) See control register GENCTRL2.

Note: The default value (after Power ON Reset) of NPOR is 0, therefore the default value of GEF is 1.

In fail safe mode, the control registers are frozen to their default value, with the exception of the WDTRIG bit (refer to Chapter 4.2.3). Any write access (except for WDTRIG bit) in fail safe mode will be discarded and the SPIE bit will set.

7.4 SPI error detection

The SPI incorporates an error flag in the Global Status Byte (SPIE) to supervise and preserve the data integrity. If an SPI protocol error is detected during a given frame, the SPIE bit is set in the next SPI communication.

The SPIE bit is set in the following error conditions:

- The number of SCLK clock pulses received when CSN is Low is (protocol error):
 - not zero
 - or less than 24
 - or more than 24 but not a multiple of 8
- The microcontroller sends an SPI command to an unused address (protocol error).
- A clock polarity error is detected (see [Figure 45](#) Case 2 and Case 3): the incoming clock signal was High during CSN rising or falling edges (protocol error).
- No address byte or no last address byte are detected (protocol error).
- In daisy chain: the microcontroller does not send in sequence the first address byte until the last address byte (i.e. with gaps between two address bytes). In this case, the SDO signal is set to '0' during the remaining part of the SPI frame¹⁸, in order to prevent other devices from executing wrong commands (protocol error).
- A clear command to address 0x1F (Device ID register, Offset address = 0x1F).
- The same half-bridge is allocated to several activated PWM channels.
- Any write or clear command received in fail safe mode and not belonging to the exit sequence (refer to [Chapter 4.2.3](#)).

Note: SPI commands to activate a half-bridge mapped to several PWM channels are ignored.

In fail safe mode, the control registers may not be accessed, except for writing WDTRIG. An invalid write command in this mode sets the SPIE bit.

For a correct SPI communication:

- SCLK must be Low for a minimum t_{BEF} before CSN falling edge and t_{lead} after CSN falling edge.
- SCLK must be Low for a minimum t_{lag} before CSN rising edge and t_{BEH} after CSN rising edge.

¹⁸ Provided that the SPI frame has a correct polarity

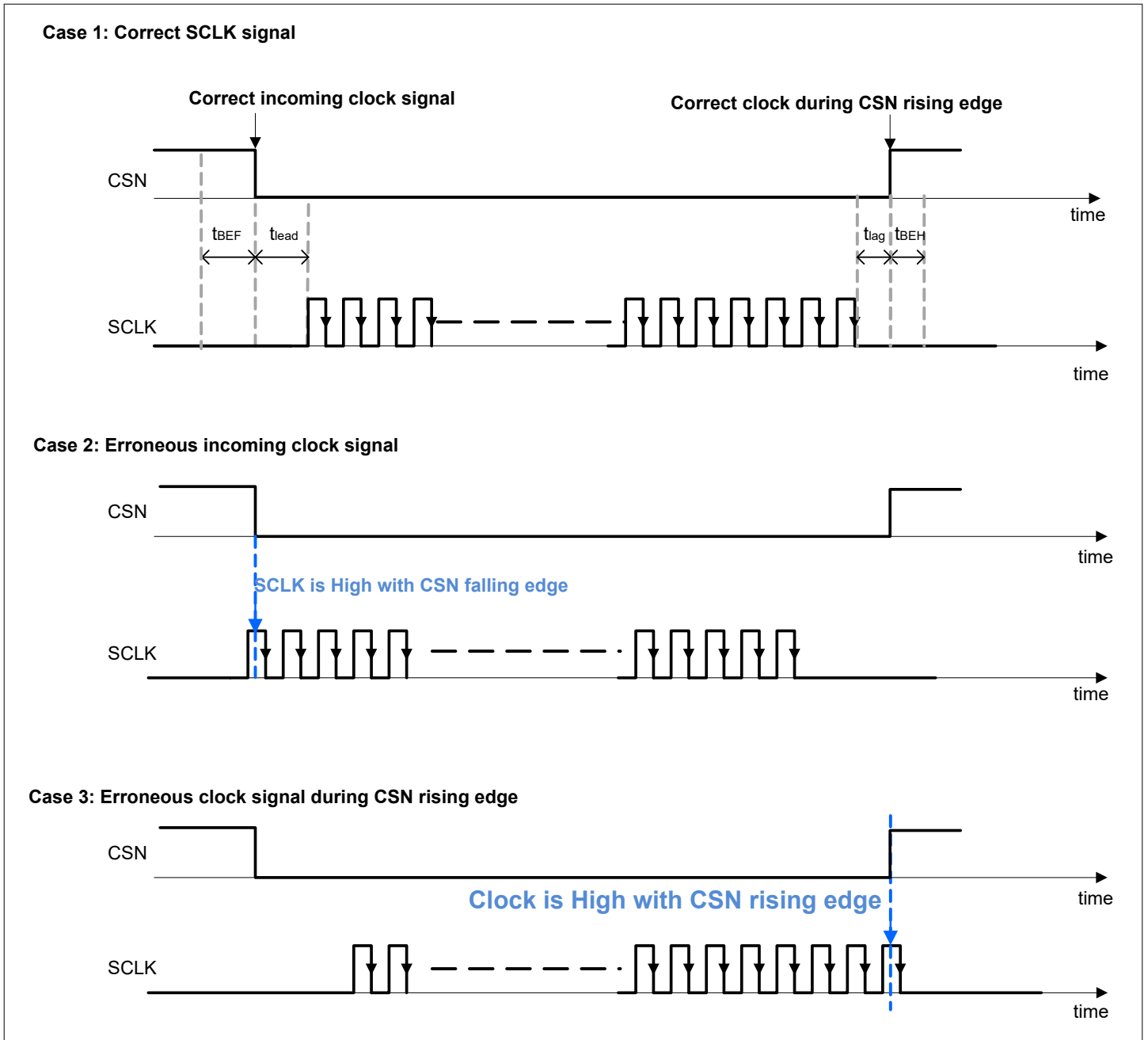

Figure 45 Clock polarity error

The reset condition of the SPIE bit depends on the cause of error:

- In normal mode:
 - The microcontroller must clear `HBVOUT_PWMERR` if one half-bridge has been allocated to several PWM channels.
 - The microcontroller must send a correct SPI frame for the other errors reported by SPIE.
- If SPIE has been set in fail safe mode, the device must enter normal mode first.

7.5 Daisy chain

In daisy chain configuration the master output / slave input (noted MOSI) is connected to a slave SDI. The first slave SDO is connected to the next slave SDI in the chain. The SDO of the final in the chain is connected to the master

input / slave output (noted MISO). In daisy chain configuration, the microcontroller MCSN is connected to all the slave CSN inputs (Figure 46).

To support daisy chain configurations, the TLE92108-232QX accepts SPI frames with more than 24 bits, provided that the number of bits is a multiple of 8, and the structure of the address byte is respected.

In daisy chain, the TLE92108-232QX works as follows:

1. The TLE92108-232QX operates as a 8-bit shift register until it receives the first address byte. This first received address byte is considered by the device as its own address byte.
2. The TLE92108-232QX copies directly SDI to SDO until the last address byte is detected.
3. The TLE92108-232QX shifts out the response high byte and low byte corresponding to the address byte.
4. After the last address byte, the TLE92108-232QX operates as a 16-bit shift register until the end of the SPI frame.

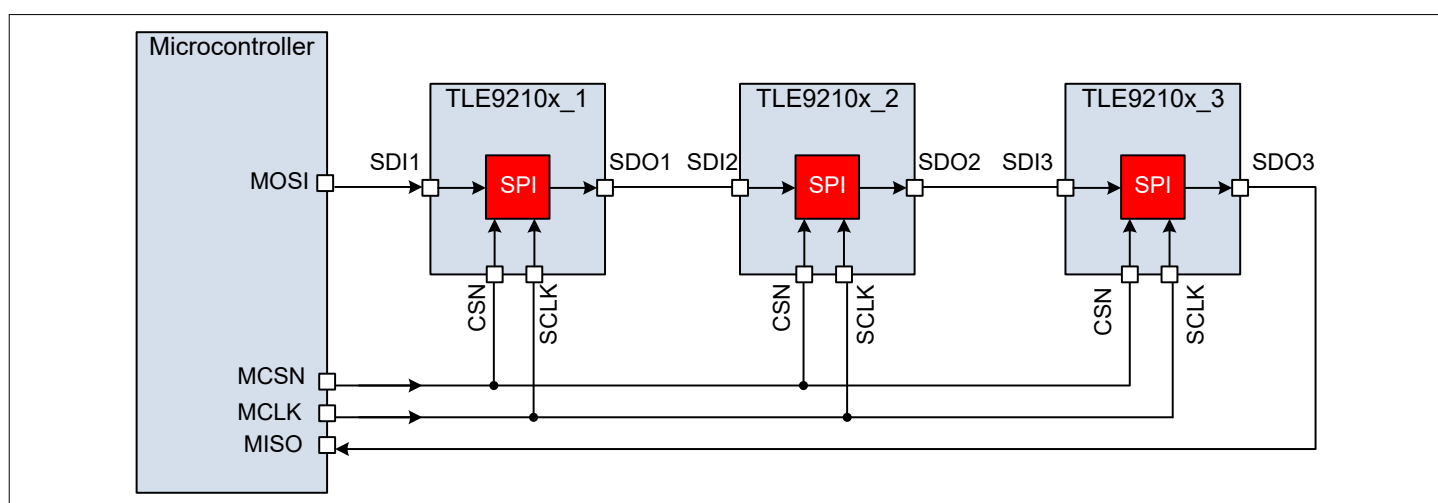

Figure 46 Daisy chain configuration with three TLE9210x devices

In daisy chain configuration (Figure 46), the microcontroller must send the address and data bytes in the following order (Figure 47):

1. The address bytes altogether are sent first:
 - Address byte 1 (for TLE9210x_1) is sent first, followed by address byte 2 (for TLE9210x_2), followed by address byte 3 (for TLE9210x_3).
 - The LABT bit of the last address byte must be '1', while the LABT bit of all the other address bytes must be '0'.
2. The data bytes are sent altogether **in reverse order** once the address bytes are transmitted:
 - The data high byte for the TLE9210x_3 is sent first followed by the data low byte for the TLE9210x_3.
 - Then the data high byte for the TLE9210x_2 is sent followed by the data low byte for the TLE9210x_2.
 - Then the data high byte for the TLE9210x_1 is sent followed by the data low byte for the TLE9210x_1.

The Master Input / Slave Output (MISO), which is connected to SDO of the last device in the daisy chain, receives:

1. A logic OR combination of all Global Error Flags (GEF) at the beginning of the SPI frame, between CSN falling edge and the first SCLK rising edge.
2. The Global Status Byte of each TLE9210x **in reverse order**:
 - The Global Status Byte 3 (GSB3) corresponding to the TLE9210x_3 is received first, followed by GSB2 (corresponding to the TLE9210x_2), and finally the GSB1 (corresponding to the TLE9210x_1) is received.
3. The response of each TLE9210x **in reverse order**:
 - The response high byte of the TLE9210x_3 is received first followed by the response low byte of the TLE9210x_3.

7 Serial Peripheral Interface - SPI

- Then the response high byte of the TLE9210x_2 is received followed by the response low byte of the TLE9210x_2.
- Then the response high byte of the TLE9210x_1 is received followed by the response low byte of the TLE9210x_1.

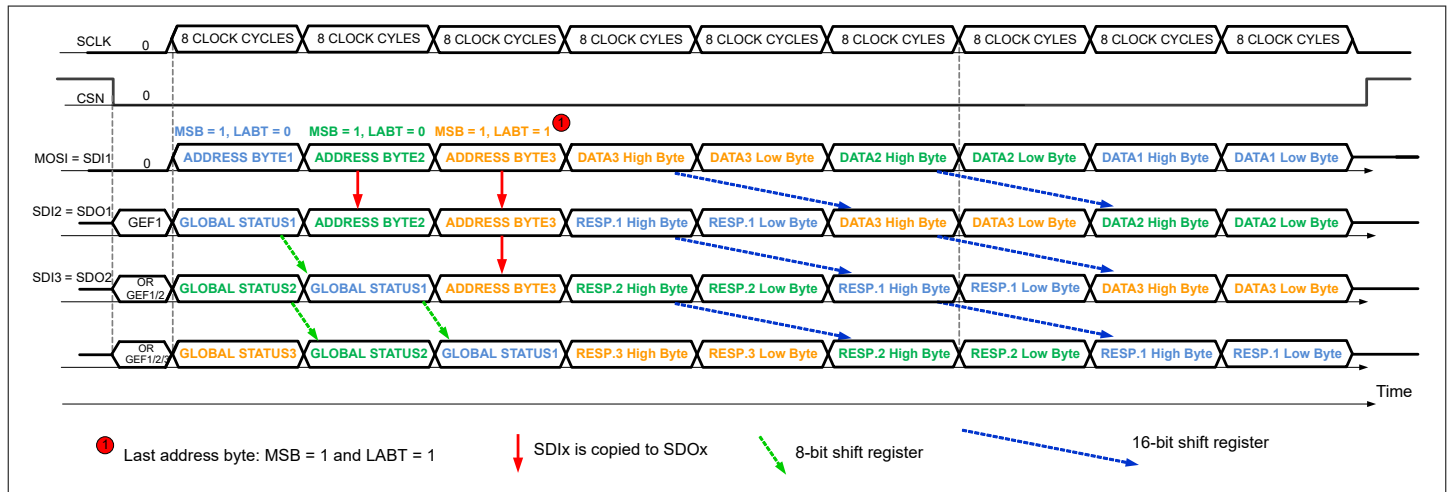

Figure 47 SPI Frame in daisy chain configuration with three TLE9210x devices

7.6 SPI electrical characteristics: timings

Table 27 Electrical characteristics: SPI interface

$V_S = 6.0\text{ V to }18\text{ V}$ if $V_{SOVTH} = 0$, $V_S = 6.0\text{ V to }28\text{ V}$ if $V_{SOVTH} = 1$; $V_{DD} = 3.0\text{ V to }5.5\text{ V}$, $T_j = -40^\circ\text{C to }150^\circ\text{C}$, all voltages with respect to ground, positive current flowing into pin (unless otherwise specified)

Parameter	Symbol	Values			Unit	Note or Test Condition	Number
		Min.	Typ.	Max.			
SPI frequency							
Maximum SPI frequency	$f_{SPI,max}$	–	–	4	MHz	¹⁾	P_8.6.1
Delay from EN rising edge to first SPI frame							
SPI interface setup time ²⁾	t_{SET_SPI}	–	–	150	μs	¹⁾	P_8.6.32
SPI interface, logic inputs SDI, SCLK, CSN							
High input voltage threshold	V_{IH}	$0.7 \times V_{DD}$	–	–	V		P_8.6.2
Low input voltage threshold	V_{IL}	–	–	$0.3 \times V_{DD}$	V		P_8.6.3
Hysteresis of input voltage	$V_{IH,Y}$	–	$0.12 \times V_{DD}$	–	V	¹⁾	P_8.6.4
Pull up resistor at pin CSN	R_{PU_CSN}	20	40	80	$k\Omega$	$V_{CSN} = 0.7 \times V_{DD}$	P_8.6.5
Pull down resistor at pin SDI, SCLK	R_{PD_SDI} , R_{PD_SCLK}	20	40	80	$k\Omega$	$V_{SDI}, V_{SCLK} = 0.2 \times V_{DD}$	P_8.6.6
Input capacitance at pin CSN, SDI or SCLK	C_I	–	10	–	pF	¹⁾ $0\text{ V} < V_{DD} < 5.5\text{ V}$	P_8.6.7
Input interface, logic outputs SDO							
H-output voltage level	V_{SDOH}	$0.8 \times V_{DD}$	–	–	V	$I_{SDOH} = -1.6\text{ mA}$	P_8.6.8
L-output voltage level	V_{SDOL}	–	–	$0.2 \times V_{DD}$	V	$I_{SDOL} = 1.6\text{ mA}$	P_8.6.9
Tri-state Leakage Current	I_{SDOLK}	-10	–	10	μA	¹⁾ $V_{CSN} = V_{DD}$; $0\text{ V} < V_{SDO} < V_{DD}$	P_8.6.10
Tri-state input capacitance	C_{SDO}	–	10	15	pF	¹⁾	P_8.6.11
Data input timing. See Figure 41							
SCLK Period	t_{pCLK}	250	–	–	ns	¹⁾	P_8.6.12
SCLK High Time	t_{SCLKH}	$0.45 \times t_{pCLK}$	–	$0.55 \times t_{pCLK}$	ns	¹⁾	P_8.6.13
SCLK Low Time	t_{SCLKL}	$0.45 \times t_{pCLK}$	–	$0.55 \times t_{pCLK}$	ns	¹⁾	P_8.6.14
SCLK Low before CSN Low	t_{BEF}	125	–	–	ns	¹⁾	P_8.6.15
CSN Setup Time	t_{lead}	250	–	–	ns	¹⁾	P_8.6.16

(table continues...)

Table 27 (continued) Electrical characteristics: SPI interface

VS = 6.0 V to 18 V if VSOVTH = 0, VS = 6.0 V to 28 V if VSOVTH = 1; VDD = 3.0 V to 5.5 V, Tj = -40°C to 150°C, all voltages with respect to ground, positive current flowing into pin (unless otherwise specified)

Parameter	Symbol	Values			Unit	Note or Test Condition	Number
		Min.	Typ.	Max.			
SCLK Setup Time	t_{lag}	250	–	–	ns	1)	P_8.6.17
SCLK Low after CSN High	t_{BEH}	125	–	–	ns	1)	P_8.6.18
SDI Setup Time	t_{SDI_setup}	100	–	–	ns	1)	P_8.6.19
SDI Hold Time	t_{SDI_hold}	50	–	–	ns	1)	P_8.6.20
Input Signal Rise Time at pin SDI, SCLK, CSN	t_{rIN}	–	–	50	ns	1)	P_8.6.21
Input Signal Fall Time at pin SDI, SCLK, CSN	t_{fIN}	–	–	50	ns	1)	P_8.6.22
Delay time from EN falling edge to standby mode	t_{DMODE}	–	–	6	µs	1)	P_8.6.23
Minimum CSN High Time	t_{CSNH}	3	–	–	µs	1)	P_8.6.24

Data output timing. See Figure 42 .

SDO Rise Time	t_{rSDO}	–	30	80	ns	1) $C_{load} = 100$ pF	P_8.6.25
SDO Fall Time	t_{fSDO}	–	30	80	ns	1) $C_{load} = 100$ pF	P_8.6.26
SDO Enable Time after CSN falling edge	t_{ENSDO}	–	–	50	ns	1) Low Impedance	P_8.6.27
SDO Disable Time after CSN rising edge	t_{DISSDO}	–	–	50	ns	1) High Impedance	P_8.6.28
Duty cycle of incoming clock at SCLK	$duty_{SCLK}$	45	–	55	%	1)	P_8.6.29
SDO Valid Time for $V_{DD} = 5V$	t_{VASDO5}	–	–	50	ns	1) $V_{SDO} < 0.2 \times V_{DD}$ $V_{SDO} > 0.8 \times V_{DD}$ $C_{load} = 100$ pF	P_8.6.31

1) Not subject to production test, specified by design

2) Delay required between EN rising edge and the moment when the device can accept SPI commands

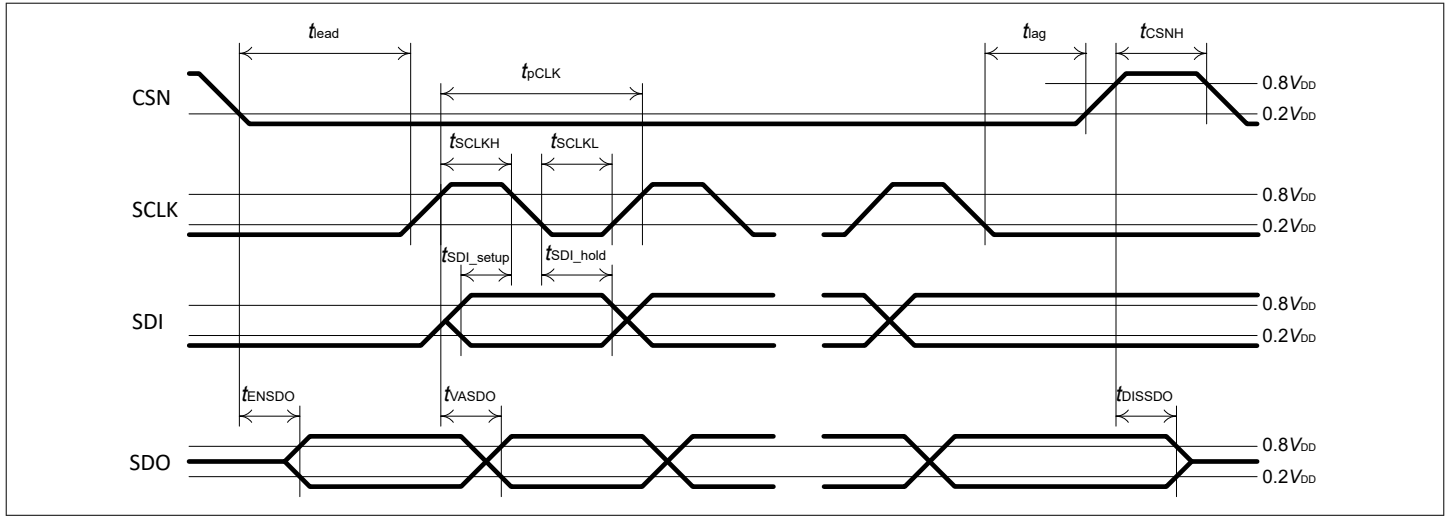

Figure 48 SPI timing parameters

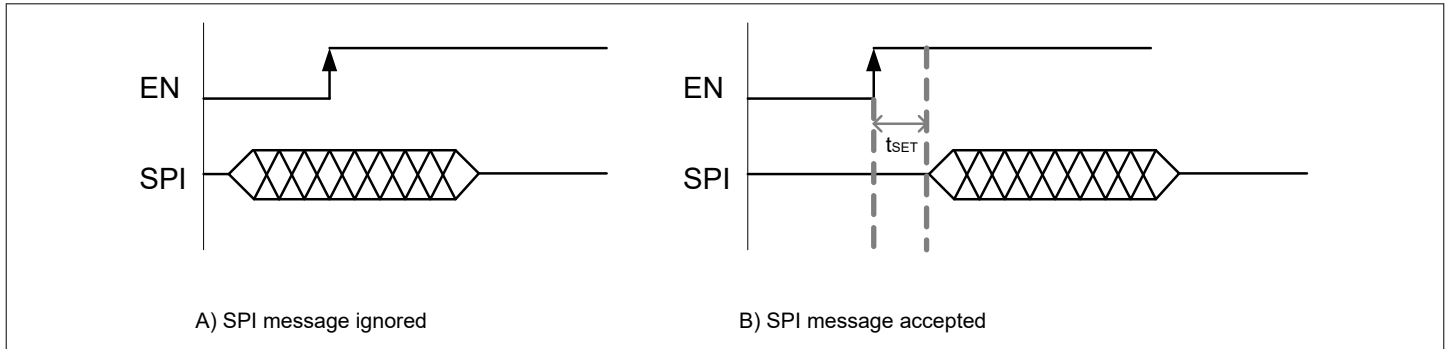

Figure 49 Setup time from EN rising edge to first SPI communication

8 Register specification

8.1 Control registers

Table 28 Register Overview

Register Short Name	Register Long Name	Offset Address	Reset Value
GENCTRL1	General control register 1	0x00 and REG_BANK = 0 or 1	0x0026
GENCTRL2	General control register 2	0x01 and REG_BANK = 0 or 1	0x4180
VDS1	Drain-source monitoring HB1-4	0x02 and REG_BANK = 0 or 1	0x0249
VDS2	Drain-source monitoring HB5-8	0x03 and REG_BANK = 0 or 1	0x0249
CCP_BLK1	Cross current protection and blank times setting 1	0x04 and REG_BANK = 0 or 1	0x0000
CCP_BLK2_ACT	Cross current protection and blank times setting for active MOSFETs ¹⁾	0x05 and REG_BANK = 0	0x4924
CCP_BLK2_FW	Cross current protection and blank times setting for FW MOSFETs ¹⁾	0x05 and REG_BANK = 1	0x4924
HBMODE	Half-bridge mode	0x06 and REG_BANK = 0 or 1	0x0000
PWMSET	Setting of PWM channels	0x07 and REG_BANK = 0 or 1	0x6C60
TPRECHG	PWM pre-charge and pre-discharge time	0x08 and REG_BANK = 0 or 1	0x0000
HBIDIAG	Half-bridge diagnostic current control	0x09 and REG_BANK = 0 or 1	0xC000
ST_ICHG	Charge current for static half-bridges	0x0A and REG_BANK = 0	0x0044
PWM_PCHG_INIT	Precharge current initialization	0x0A and REG_BANK = 1	0x18C6
PWM_ICHG_ACT	Charge current for half-bridges in PWM (active MOSFETs ¹⁾)	0x0B and REG_BANK = 0	0x18C6
PWM_ICHG_FW	Charge current for half-bridges in PWM (FW MOSFETs ¹⁾)	0x0B and REG_BANK = 1	0x18C6
PWM_IDCHG_ACT	Discharge current of active MOSFETs ¹⁾ in PWM operation	0x0C and REG_BANK = 0	0x1CE7
PWM_PDCHG_INIT	Predischarge current initialization	0x0C and REG_BANK = 1	0x318C
PWM_ICHGMAX_CCP_BLK3_ACT	Max. pre-charge / pre-discharge currents for half-bridges in PWM ²⁾ , tCCP and tBLANK setting for active MOSFETs ¹⁾	0x0D and REG_BANK = 0	0x4900
PWM_ICHGMAX_CCP_BLK3_FW	Max. pre-charge / pre-discharge currents for half-bridges in PWM ²⁾ , tCCP and tBLANK setting for FW MOSFETs ¹⁾	0x0D and REG_BANK = 1	0x4900
TDON_OFF1	Turn-on and turn-off delays for PWM channel1	0x0E and REG_BANK = 0 or 1	0x0A0A

(table continues...)

Table 28 (continued) Register Overview

Register Short Name	Register Long Name	Offset Address	Reset Value
TDON_OFF2	Turn-on and turn-off delays for PWM channel2	0x0F and REG_BANK = 0 or 1	0x0A0A
TDON_OFF3	Turn-on and turn-off delays for PWM channel3	0x10 and REG_BANK = 0 or 1	0x0A0A

- 1) Refer to [Chapter 5.3.1](#) for the definition of the active and the free-wheeling MOSFETs, depending on the setting of AGC
 2) ICHGMAX is also the current applied to the Active MOSFET during post-discharge.

8.1.1 General Control Registers and Protection Settings

8.1.1.1 General control register 1

GENCTRL1 Address: 0 0000_B
 General Control Register 1 Reset value: 0000 0000 0010 0110_B

15	14	13	12	11	10	9	8	7	6	5	4	3	2	1	0
CSD2	CSAG2	CSD1	CSAG1	REG_BANK	VSOV TH	UNL OCK	Reser ved	FMO DE	Reser ved	IPCH GADT	OCEN	WDP ER	WDT RIG		
rw	rw	rw	rw	rw	rw	rw	r	rw	r	rw	rw	rw	rw		

Field	Bits	Type	Description
CSD2	15	rw	Direction of the current sense amplifier 2 0 _B The current sense is unidirectional (default) 1 _B The current sense is bidirectional
CSAG2	14:13	rw	Gain of the current sense amplifier 2 00 _B 10 V/V (default) 01 _B 20 V/V 10 _B 40 V/V 11 _B 80 V/V
CSD1	12	rw	Direction of the current sense amplifier 1 0 _B The current sense is unidirectional (default) 1 _B The current sense is bidirectional
CSAG1	11:10	rw	Gain of the current sense amplifier 1 00 _B 10 V/V (default) 01 _B 20 V/V 10 _B 40 V/V 11 _B 80 V/V

(table continues...)

(continued)

Field	Bits	Type	Description
REG_BANK	9	rw	Register banking 0_B (Default) refer to CCP_BLK2_ACT , PWM_ICHGMAX_CCP_BLK3_ACT , PWM_ICHG_ACT , ST_ICHG , PWM_IDCHG_ACT 1_B Refer to CCP_BLK2_FW , PWM_ICHGMAX_CCP_BLK3_FW , PWM_ICHG_FW , PWM_PDCHG_INIT , PWM_PCHG_INIT
VSOVTH	8	rw	VS Overvoltage threshold 0_B $V_{SOV\ OFF} = V_{SOV\ OFF1}$ (min. 19 V, default) 1_B $V_{SOV\ OFF} = V_{SOV\ OFF2}$ (min. 29V)
UNLOCK	7	rw	Unlock bit to disable the watchdog 0_B WDDIS cannot be reset (default) 1_B WDDIS (GENCTRL2) can be reset in the following SPI frame
Reserved	6	r	Reserved. Always read as '0'
FMODE	5	rw	Frequency modulation 0_B No modulation 1_B Modulation frequency 15.6 kHz (default)
Reserved	4	r	Reserved. Always read as '0'
IPCHGADT	3	rw	Adaptation of the pre-charge and pre-discharge current 0_B 1 current step (default) 1_B 2 current steps
OCEN	2	rw	Overcurrent shutdown Enable 0_B Disabled 1_B Enabled (default)
WDPER	1	rw	Watchdog period 0_B 50 ms 1_B 200 ms (default)
WDTRIG	0	rw	Watchdog trigger bit This bit must be inverted within a watchdog period. After power on reset, the default value is 0.

Attention: Any write access to this register must invert the **WDTRIG** bit. Otherwise, the device enters fail safe mode. Refer to [Chapter 4.2.3](#).

8.1.1.2 General control register 2

GENCTRL2

Address:

0 0001_B

General Control Register 2

Reset value:

0100 0001 1000 0000_B

15	14	13	12	11	10	9	8	7	6	5	4	3	2	1	0
POCH GDIS	BD_P ASS	AGCF ILT	AGC	IHOL D	WDDI S	MSKT DREG	CPUV TH	CPST GA	TFVDS	OCTH2	OCTH1				
rw	rw	rw	rw	rw	rw	rw	rw	rw	rw	rw	rw	rw	rw	rw	rw

Field	Bits	Type	Description
POCHGDIS	15	rw	Postcharge disable bit 0 _B The postcharge phase is enabled during PWM (default) 1 _B The postcharge phase is disabled during PWM
BD_PASS	14	rw	Bridge driver passive mode 0 _B Bridge driver is in active mode 1 _B Bridge driver is in passive mode (Default)
AGCFILT	13	rw	Filter for adaptive gate control Note: Refer to Adaptive control of pre-charge current and Adaptive control of pre-discharge current 0 _B No filter applied (default) 1 _B Filter applied
AGC	12:11	rw	Adaptive gate control 00 _B (default) Adaptive gate control disabled, pre-charge and pre-discharge disabled 01 _B Adaptive gate control disabled, precharge is disabled, pre-discharge is enabled with IPREDCHG = IPDCHGINIT (Refer to PWM_PCHG_INIT) 10 _B Adaptive gate control enabled, IPRECHG and IPREDCHG are self adapted 11 _B Reserved. Adaptive gate control enabled, IPRECHG and IPREDCHG are self adapted
IHOLD	10	rw	Gate driver hold current IHOLD 0 _B (default) Charge: I _{CHG8} (12.5 mA typ.), discharge I _{DCHG8} (14.2 mA typ.) 1 _B Charge: I _{CHG12} (23.9 mA typ.), discharge: I _{DCHG12} (26.0 mA typ.)
WDDIS	9	rw	Watchdog disable bit 0 _B the watchdog is enabled (default) 1 _B the watchdog is disabled if the previous SPI frame has set UNLOCK bit (GENCTRL1) Once the watchdog is disabled, it is directly re-enabled by resetting WDDIS
MSKTDREG	8	rw	Masking of the turn-on/off delay error in the Global Error Flag 0 _B Turn-on/off delay error is reported in the GEF 1 _B Turn-on/off delay error is masked in the GEF (default)
CPUVTH	7	rw	Charge pump undervoltage detection threshold 0 _B V _{CPUV} (referred to VS) = 6.0V typ. 1 _B V _{CPUV} (referred to VS)= 7.5 V typ. (default)
CPSTGA	6	rw	Automatic switch-over between dual and single charge pump stage 0 _B Automatic switch over deactivated (default) 1 _B Automatic switch over activated

(table continues...)

(continued)

Field	Bits	Type	Description
TFVDS	5:4	rw	Filter time of drain-source voltage monitoring 00 _B 0.5 μs (default) 01 _B 1 μs 10 _B 2 μs 11 _B 3 μs
OCTH2	3:2	rw	Overcurrent detection threshold of CSO2 with CSD2 = 0 00 _B $V_{CSO2} > V_{DD/2}$ (default) 01 _B $V_{CSO2} > V_{DD/2} + V_{DD}/10$ 10 _B $V_{CSO2} > V_{DD/2} + 2 \times V_{DD}/10$ 11 _B $V_{CSO2} > V_{DD/2} + 3 \times V_{DD}/10$ Overcurrent detection threshold of CSO2 with CSD2 = 1 00 _B $V_{CSO2} > V_{DD/2} + 2 \times V_{DD}/20$ or $V_{CSO2} < V_{DD/2} - 2 \times V_{DD}/20$ (default) 01 _B $V_{CSO2} > V_{DD/2} + 4 \times V_{DD}/20$ or $V_{CSO2} < V_{DD/2} - 4 \times V_{DD}/20$ 10 _B $V_{CSO2} > V_{DD/2} + 5 \times V_{DD}/20$ or $V_{CSO2} < V_{DD/2} - 5 \times V_{DD}/20$ 11 _B $V_{CSO2} > V_{DD/2} + 6 \times V_{DD}/20$ or $V_{CSO2} < V_{DD/2} - 6 \times V_{DD}/20$
OCTH1	1:0	rw	Overcurrent detection threshold of CSO1 with CSD1 = 0 00 _B $V_{CSO1} > V_{DD/2}$ (default) 01 _B $V_{CSO1} > V_{DD/2} + V_{DD}/10$ 10 _B $V_{CSO1} > V_{DD/2} + 2 \times V_{DD}/10$ 11 _B $V_{CSO1} > V_{DD/2} + 3 \times V_{DD}/10$ Overcurrent detection threshold of CSO1 with CSD1 = 1 00 _B $V_{CSO1} > V_{DD/2} + 2 \times V_{DD}/20$ or $V_{CSO1} < V_{DD/2} - 2 \times V_{DD}/20$ (default) 01 _B $V_{CSO1} > V_{DD/2} + 4 \times V_{DD}/20$ or $V_{CSO1} < V_{DD/2} - 4 \times V_{DD}/20$ 10 _B $V_{CSO1} > V_{DD/2} + 5 \times V_{DD}/20$ or $V_{CSO1} < V_{DD/2} - 5 \times V_{DD}/20$ 11 _B $V_{CSO1} > V_{DD/2} + 6 \times V_{DD}/20$ or $V_{CSO1} < V_{DD/2} - 6 \times V_{DD}/20$

8.1.1.3 Drain-source monitoring threshold HB1-4

VDS1 Address: 0 0010_B
 Drain-source monitoring threshold HB1-4 Reset value: 0000 0010 0100 1001_B

15	14	13	12	11	10	9	8	7	6	5	4	3	2	1	0
HB4D	HB3D	HB2D	HB1D	HB4VDSTH			HB3VDSTH			HB2VDSTH			HB1VDSTH		
rw	rw	rw	rw	rw			rw			rw			rw		

Field	Bits	Type	Description
HB4D	15	rw	HS4 Drain-source monitoring ¹⁾ 0 _B Drain-source monitoring: DH - VSH4 (default) 1 _B Drain-source monitoring: CSIN1 - VSH4
HB3D	14	rw	HS3 Drain-source monitoring ¹⁾ 0 _B Drain-source monitoring: DH - VSH3 (default) 1 _B Drain-source monitoring: CSIN1 - VSH3

(table continues...)

(continued)

Field	Bits	Type	Description
HB2D	13	rw	HS2 Drain-source monitoring ¹⁾ 0 _B Drain-source monitoring: DH - VSH2 (default) 1 _B Drain-source monitoring: CSIN1 - VSH2
HB1D	12	rw	HS1 Drain-source monitoring ¹⁾ 0 _B Drain-source monitoring: DH - VSH1 (default) 1 _B Drain-source monitoring: CSIN1 - VSH1
HB4VDSTH	11:9	rw	HB4 drain-source overvoltage threshold 000 _B 0.15 V 001 _B 0.20 V (default) 010 _B 0.25 V 011 _B 0.30 V 100 _B 0.40 V 101 _B 0.50 V 110 _B 0.60 V 111 _B 2.0 V
HB3VDSTH	8:6	rw	HB3 drain-source overvoltage threshold 000 _B 0.15 V 001 _B 0.20 V (default) 010 _B 0.25 V 011 _B 0.30 V 100 _B 0.40 V 101 _B 0.50 V 110 _B 0.60 V 111 _B 2.0 V
HB2VDSTH	5:3	rw	HB2 drain-source overvoltage threshold 000 _B 0.15 V 001 _B 0.20 V (default) 010 _B 0.25 V 011 _B 0.30 V 100 _B 0.40 V 101 _B 0.50 V 110 _B 0.60 V 111 _B 2.0 V
HB1VDSTH	2:0	rw	HB1 drain-source overvoltage threshold 000 _B 0.15 V 001 _B 0.20 V (default) 010 _B 0.25 V 011 _B 0.30 V 100 _B 0.40 V 101 _B 0.50 V 110 _B 0.60 V 111 _B 2.0 V

1) Applicable for HSx. The Drain-Source overvoltage for LSx is done by monitoring VSHx - VSL.

8.1.1.4 Drain-source monitoring threshold HB5-8

VDS2 Address: 0 0011_B
 Drain-source monitoring threshold HB5-8 Reset value: 0000 0010 0100 1001_B

15	14	13	12	11	10	9	8	7	6	5	4	3	2	1	0
HB8D	HB7D	HB6D	HB5D	HB8VDSTH			HB7VDSTH			HB6VDSTH			HB5VDSTH		
rw	rw	rw	rw	rw			rw			rw			rw		

Field	Bits	Type	Description
HB8D	15	rw	HS8 Drain-source monitoring ¹⁾ 0 _B Drain-source monitoring: DH - VSH8 (default) 1 _B Drain-source monitoring: CSIN1 - VSH8
HB7D	14	rw	HS7 Drain-source monitoring ¹⁾ 0 _B Drain-source monitoring: DH - VSH7 (default) 1 _B Drain-source monitoring: CSIN1 - VSH7
HB6D	13	rw	HS6 Drain-source monitoring ¹⁾ 0 _B Drain-source monitoring: DH - VSH6 (default) 1 _B Drain-source monitoring: CSIN1 - VSH6
HB5D	12	rw	HS5 Drain-source monitoring ¹⁾ 0 _B Drain-source monitoring: DH - VSH5 (default) 1 _B Drain-source monitoring: CSIN1 - VSH5
HB8VDSTH	11:9	rw	HB8 drain-source overvoltage threshold 000 _B 0.15 V 001 _B 0.20 V (default) 010 _B 0.25 V 011 _B 0.30 V 100 _B 0.40 V 101 _B 0.50 V 110 _B 0.60 V 111 _B 2.0 V
HB7VDSTH	8:6	rw	HB7 drain-source overvoltage threshold 000 _B 0.15 V 001 _B 0.20 V (default) 010 _B 0.25 V 011 _B 0.30 V 100 _B 0.40 V 101 _B 0.50 V 110 _B 0.60 V 111 _B 2.0 V

(table continues...)

(continued)

Field	Bits	Type	Description
HB6VDSTH	5:3	rw	HB6 drain-source overvoltage threshold 000 _B 0.15 V 001 _B 0.20 V (default) 010 _B 0.25 V 011 _B 0.30 V 100 _B 0.40 V 101 _B 0.50 V 110 _B 0.60 V 111 _B 2.0 V
HB5VDSTH	2:0	rw	HB5 drain-source overvoltage threshold 000 _B 0.15 V 001 _B 0.20 V (default) 010 _B 0.25 V 011 _B 0.30 V 100 _B 0.40 V 101 _B 0.50 V 110 _B 0.60 V 111 _B 2.0 V

1) Applicable for HSx. The Drain-Source overvoltage for LSx is done by monitoring VSHx - VSL.

8.1.1.5 Cross current protection and blank time setting 1

CCP_BLK1 Address: 0 0100_B
 CCP and Blank times setting 1 Reset value: 0000 0000 0000 0000_B

15	14	13	12	11	10	9	8	7	6	5	4	3	2	1	0
HB8CCPBLK	HB7CCPBLK	HB6CCPBLK	HB5CCPBLK	HB4CCPBLK	HB3CCPBLK	HB2CCPBLK	HB1CCPBLK								
rw	rw	rw	rw	rw	rw	rw	rw								

Field	Bits	Type	Description
HB8CCPBLK	15:14	rw	Cross-current protection and blank times applied to HB8 00 _B (tHB8CCP, tHB8BLANK) = (tCCP1, tBLANK1) (default) 01 _B (tHB8CCP, tHB8BLANK) = (tCCP2, tBLANK2) 10 _B (tHB8CCP, tHB8BLANK) = (tCCP3, tBLANK3) 11 _B (tHB8CCP, tHB8BLANK) = (tCCP4, tBLANK4)
HB7CCPBLK	13:12	rw	Cross-current protection and blank times applied to HB7 00 _B (tHB7CCP, tHB7BLANK) = (tCCP1, tBLANK1) (default) 01 _B (tHB7CCP, tHB7BLANK) = (tCCP2, tBLANK2) 10 _B (tHB7CCP, tHB7BLANK) = (tCCP3, tBLANK3) 11 _B (tHB7CCP, tHB7BLANK) = (tCCP4, tBLANK4)

(table continues...)

(continued)

Field	Bits	Type	Description
HB6CCPBLK	11:10	rw	Cross-current protection and blank times applied to HB6 00 _B (tHB6CCP, tHB6BLANK) = (tCCP1, tBLANK1) (default) 01 _B (tHB6CCP, tHB6BLANK) = (tCCP2, tBLANK2) 10 _B (tHB6CCP, tHB6BLANK) = (tCCP3, tBLANK3) 11 _B (tHB6CCP, tHB6BLANK) = (tCCP4, tBLANK4)
HB5CCPBLK	9:8	rw	Cross-current protection and blank times applied to HB5 00 _B (tHB5CCP, tHB5BLANK) = (tCCP1, tBLANK1) (default) 01 _B (tHB5CCP, tHB5BLANK) = (tCCP2, tBLANK2) 10 _B (tHB5CCP, tHB5BLANK) = (tCCP3, tBLANK3) 11 _B (tHB5CCP, tHB5BLANK) = (tCCP4, tBLANK4)
HB4CCPBLK	7:6	rw	Cross-current protection and blank times applied to HB4 00 _B (tHB4CCP, tHB4BLANK) = (tCCP1, tBLANK1) (default) 01 _B (tHB4CCP, tHB4BLANK) = (tCCP2, tBLANK2) 10 _B (tHB4CCP, tHB4BLANK) = (tCCP3, tBLANK3) 11 _B (tHB4CCP, tHB4BLANK) = (tCCP4, tBLANK4)
HB3CCPBLK	5:4	rw	Cross-current protection and blank times applied to HB3 00 _B (tHB3CCP, tHB3BLANK) = (tCCP1, tBLANK1) (default) 01 _B (tHB3CCP, tHB3BLANK) = (tCCP2, tBLANK2) 10 _B (tHB3CCP, tHB3BLANK) = (tCCP3, tBLANK3) 11 _B (tHB3CCP, tHB3BLANK) = (tCCP4, tBLANK4)
HB2CCPBLK	3:2	rw	Cross-current protection and blank times applied to HB2 00 _B (tHB2CCP, tHB2BLANK) = (tCCP1, tBLANK1) (default) 01 _B (tHB2CCP, tHB2BLANK) = (tCCP2, tBLANK2) 10 _B (tHB2CCP, tHB2BLANK) = (tCCP3, tBLANK3) 11 _B (tHB2CCP, tHB2BLANK) = (tCCP4, tBLANK4)
HB1CCPBLK	1:0	rw	Cross-current protection and blank times applied to HB1 00 _B (tHB1CCP, tHB1BLANK) = (tCCP1, tBLANK1) (default) 01 _B (tHB1CCP, tHB1BLANK) = (tCCP2, tBLANK2) 10 _B (tHB1CCP, tHB1BLANK) = (tCCP3, tBLANK3) 11 _B (tHB1CCP, tHB1BLANK) = (tCCP4, tBLANK4)

Refer to [CCP_BLK2_ACT](#), [PWM_ICHGMAX_CCP_BLK3_ACT](#), [CCP_BLK2_FW](#) and [PWM_ICHGMAX_CCP_BLK3_FW](#) for the setting of (tCCPx, tBLANKx), x = 1 ... 4.

8.1.1.6 Cross current protection and blank time setting 2 for active MOSFETs

Attention: This register is accessed with [REG_BANK](#) = 0 and the offset address 0 0101B. tCCP and tBLANK are applicable to the active MOSFETs.

CCP_BLK2_ACT

Address:

0 0101_B

Active CCP and Blank times setting 2

Reset value:

0100 1001 0010 0100_B

8 Register specification

15	14	13	12	11	10	9	8	7	6	5	4	3	2	1	0
Reser ved	TCCP3_ACT			TBLANK2_ACT			TCCP2_ACT			TBLANK1_ACT			TCCP1_ACT		
r	rw			rw			rw			rw			rw		

Field	Bits	Type	Description
Reserved	15	r	Reserved. Always read as '0'
TCCP3_ACT	14:12	rw	Cross-current protection - tCCP3 Active Refer to Table 29 Default: 100 _B ; typ. 2000 ns
TBLANK2_ACT	11:9	rw	Blank time - tBLANK2 Active Refer to Table 30 Default: 100 _B ; typ. 2000 ns
TCCP2_ACT	8:6	rw	Cross-current protection - tCCP2 Active Refer to Table 29 Default: 100 _B ; typ. 2000 ns
TBLANK1_ACT	5:3	rw	Blank time - tBLANK1 Active Refer to Table 30 Default: 100 _B ; typ. 2000 ns
TCCP1_ACT	2:0	rw	Cross-current protection - tCCP1 Active Refer to Table 29 Default: 100 _B ; typ. 2000 ns

Table 29 Cross-current protection time for active MOSFETs

TCCPx_ACT[2:0], x = 1...4	Active cross-current protection HBx, x = 1...4 (typical)
000 _B	375 ns
001 _B	625 ns
010 _B	1 μs
011 _B	1.5 μs
100 _B	2 μs (default)
101 _B	3 μs
110 _B	4 μs
111 _B	16 μs ¹⁾

1) When applying a cross-current protection time of 16 μs to a half-bridge, the max. drive current used for this half-bridge must be set below 30 mA, to avoid an overheating of the gate driver. Refer to register [ST_ICHG](#) for static controlled half-bridges and [PWM_IDCHG_ACT](#) for half-bridges controlled in PWM.

Table 30 Drain-Source overvoltage blank time for active MOSFETs

TBLANKx_ACT[2:0], x = 1...4	Active drain-Source overvoltage blank time tBLANKx, x = 1...4 (typical)
000 _B	625 ns

(table continues...)

Table 30 (continued) Drain-Source overvoltage blank time for active MOSFETs

TBLANKx_ACT[2:0], x = 1...4	Active drain-Source overvoltage blank time tBLANKx, x = 1...4 (typical)
001 _B	1 μs
010 _B	1.25 μs
011 _B	1.5 μs
100 _B	2 μs (default)
101 _B	3 μs
110 _B	4 μs
111 _B	16 μs ¹⁾

1) When applying a drain-source overvoltage blank time of 16 μs to a half-bridge, the max. drive current used for this half-bridge must be set below 30 mA, to avoid an overheating of the gate driver. Refer to register [ST_ICHG](#) for static controlled half-bridges and [PWM_ICHG_ACT](#) for half-bridges controlled in PWM.

Refer to [PWM_ICHGMAX_CCP_BLK3_ACT](#) for the setting of tBLANK4, tCCP4 and tBLANK3 for the active MOSFETs.
Refer to [CCP_BLK1](#) for the mapping of (tCCPx,tBLANKx) to the half-bridges.

8.1.1.7 Cross current protection and blank time setting 2 for FW MOSFETs

Attention: This register is accessed with [REG_BANK](#) = 1 and the offset address 0 0101B. tCCP and tBLANK are applicable to the FW MOSFETs.

CCP_BLK2_FW Address: 0 0101_B
FW CCP and Blank times setting 2 Reset value: 0100 1001 0010 0100_B

15	14	13	12	11	10	9	8	7	6	5	4	3	2	1	0
Reser ved	TCCP3_FW		TBLANK2_FW			TCCP2_FW		TBLANK1_FW			TCCP1_FW				
r	rw		rw			rw		rw			rw				

Field	Bits	Type	Description
Reserved	15	r	Reserved. Always read as '0'
TCCP3_FW	14:12	rw	Cross-current protection - tCCP3 Freewheeling Refer to Table 31 Default: 100 _B ; typ. 2000 ns
TBLANK2_FW	11:9	rw	Blank time - tBLANK2 Freewheeling Refer to Table 32 Default: 100 _B ; typ. 2000 ns
TCCP2_FW	8:6	rw	Cross-current protection - tCCP2 Freewheeling Refer to Table 31 Default: 100 _B ; typ. 2000 ns

(table continues...)

(continued)

Field	Bits	Type	Description
TBLANK1_FW	5:3	rw	Blank time - tBLANK1 Freewheeling Refer to Table 32 Default: 100 _B ; typ. 2000 ns
TCCP1_FW	2:0	rw	Cross-current protection - tCCP1 Freewheeling Refer to Table 31 Default: 100 _B ; typ. 2000 ns

Table 31 Cross-current protection time for FW MOSFETs

TCCPx_FW[2:0], x = 1...4	FW cross-current protection HBx, x = 1...4 (typical)
000 _B	375 ns
001 _B	625 ns
010 _B	1 μs
011 _B	1.5 μs
100 _B	2 μs (default)
101 _B	3 μs
110 _B	4 μs
111 _B	16 μs ¹⁾

1) When applying a cross-current protection time of 16 μs to a half-bridge, the max. drive current used for this half-bridge must be set below 30 mA, to avoid an overheating of the gate driver. Refer to register [ST_ICHG](#) for static controlled half-bridges and [PWM_ICHG_FW](#) for half-bridges controlled in PWM.

Table 32 Drain-Source overvoltage blank time for FW MOSFETs

TBLANKx_FW[2:0], x = 1...4	FW Drain-Source overvoltage blank time tBLANKx, x = 1...4 (typical)
000 _B	625 ns
001 _B	1 μs
010 _B	1.25 μs
011 _B	1.5 μs
100 _B	2 μs (default)
101 _B	3 μs
110 _B	4 μs
111 _B	16 μs ¹⁾

1) When applying a drain-source overvoltage blank time of 16 μs to a half-bridge, the max. drive current used for this half-bridge must be set below 30 mA, to avoid an overheating of the gate driver. Refer to register [ST_ICHG](#) for static controlled half-bridges and [PWM_ICHG_FW](#) for half-bridges controlled in PWM.

Refer to [PWM_ICHGMAX_CCP_BLK3_FW](#) for the setting of tBLANK4, tCCP4 and tBLANK3 for the FW MOSFETs.

Refer to [CCP_BLK1](#) for the mapping of (tCCPx,tBLANKx) to the half-bridges.

8.1.2 Half-bridge control

8.1.2.1 Half-bridge mode

HBMODE **Address:** 0 0110_B
 Half-bridge mode **Reset value:** 0_B

15	14	13	12	11	10	9	8	7	6	5	4	3	2	1	0
HB8MODE	HB7MODE	HB6MODE	HB5MODE	HB4MODE	HB3MODE	HB2MODE	HB1MODE								
rw	rw	rw	rw	rw	rw	rw	rw								

Field	Bits	Type	Description
HB8MODE	15:14	rw	Half-bridge output 8 mode selection 00 _B HB8 is in high impedance (default) 01 _B LS8 is ON 10 _B HS8 is ON 11 _B Reserved - HB8 is in high impedance
HB7MODE	13:12	rw	Half-bridge output 7 mode selection 00 _B HB7 is in high impedance (default) 01 _B LS7 is ON 10 _B HS7 is ON 11 _B Reserved - HB7 is in high impedance
HB6MODE	11:10	rw	Half-bridge output 6 mode selection 00 _B HB6 is in high impedance (default) 01 _B LS6 is ON 10 _B HS6 is ON 11 _B Reserved - HB6 is in high impedance
HB5MODE	9:8	rw	Half-bridge output 5 mode selection 00 _B HB5 is in high impedance (default) 01 _B LS5 is ON 10 _B HS5 is ON 11 _B Reserved - HB5 is in high impedance
HB4MODE	7:6	rw	Half-bridge output 4 mode selection 00 _B HB4 is in high impedance (default) 01 _B LS4 is ON 10 _B HS4 is ON 11 _B Reserved - HB4 is in high impedance
HB3MODE	5:4	rw	Half-bridge output 3 mode selection 00 _B HB3 is in high impedance (default) 01 _B LS3 is ON 10 _B HS3 is ON 11 _B Reserved - HB3 is in high impedance

(table continues...)

(continued)

Field	Bits	Type	Description
HB2MODE	3:2	rw	Half-bridge output 2 mode selection 00 _B HB2 is in high impedance (default) 01 _B LS2 is ON 10 _B HS2 is ON 11 _B Reserved - HB2 is in high impedance
HB1MODE	1:0	rw	Half-bridge output 1 mode selection 00 _B HB1 is in high impedance (default) 01 _B LS1 is ON 10 _B HS1 is ON 11 _B Reserved - HB1 is in high impedance

8.1.2.2 PWM channel settings

PWMSET Address: 0 0111_B
 PWM channel settings Reset value: 0110 1100 0110 0000_B

15	14	13	12	11	10	9	8	7	6	5	4	3	2	1	0
Reser ved	PASS _VDS	PASS_MOD		PWM3_HB	PWM 3_EN		PWM2_HB	PWM 2_EN		PWM1_HB	PWM 1_EN				
r	rw	rw		rw	rw		rw	rw		rw	rw				

Field	Bits	Type	Description
Reserved	15	r	Reserved. Always read as '0'
PASS_VDS	14	rw	Drain-Source monitoring in bridge passive mode 0 _B DS monitoring in bridge passive mode disabled 1 _B DS monitoring in bridge passive mode enabled (Default)
PASS_MOD	13:12	rw	Settings for bridge driver passive mode 00 _B LS1-4 are always off Note: Changing PASS_MOD from 00 _B to any other value requires to clear DSOV ¹⁾ first before writing PASS_MOD, 01 _B LS1-4 are always on (static brake) 10 _B LS1-4 are activated if passive VS OV is detected (overvoltage brake) (Default) 11 _B LS1-4 are activated if passive VS OV is detected and PWM1 = High (overvoltage brake conditioned by PWM1)

(table continues...)

(continued)

Field	Bits	Type	Description
PWM3_HB	11:9	rw	Allocation of the PWM channel 3 000 _B HB1 001 _B HB2 010 _B HB3 011 _B HB4 100 _B HB5 101 _B HB6 110 _B HB7 (default) 111 _B HB8
PWM3_EN	8	rw	PWM channel 3 enable 0 _B PWM3 is disabled (default) 1 _B PWM3 is enabled
PWM2_HB	7:5	rw	Allocation of the PWM channel 2 000 _B HB1 001 _B HB2 010 _B HB3 011 _B HB4 (Default) 100 _B HB5 101 _B HB6 110 _B HB7 111 _B HB8
PWM2_EN	4	rw	PWM channel 2 enable 0 _B PWM2 is disabled (default) 1 _B PWM2 is enabled
PWM1_HB	3:1	rw	Allocation of the PWM channel 1 000 _B HB1 (default) 001 _B HB2 010 _B HB3 011 _B HB4 100 _B HB5 101 _B HB6 110 _B HB7 111 _B HB8
PWM1_EN	0	rw	PWM channel 1 enable 0 _B PWM1 is disabled (default) 1 _B PWM1 is enabled

1) If [DSOV](#) is not cleared first, the value of [PASS_MOD](#) stays at 00_B

If the same half-bridge is mapped to several activated PWM channels, then a SPI error is reported and the impacted half-bridge is in high-impedance.

8.1.2.3 PWM pre-charge and pre-discharge time

8 Register specification

TPRECHG Address: 0 1000_B
 Charge and pre-charge time Reset value: 0_B

	15	14	13	12	11	10	9	8	7	6	5	4	3	2	1	0
	Reser ved	EN_D EEP_ AD	Reser ved	EN_G EN_C HECK	TPDCHG3	TPCHG3	TPDCHG2	TPCHG2	TPDCHG1	TPCHG1						
	rw	rw	rw	rw	rw	rw	rw	rw	rw	rw	rw	rw	rw	rw	rw	rw

Field	Bits	Type	Description
Reserved	15	rw	Reserved. To be programmed as '0'.
EN_DEEP_AD	14	rw	Deep adaptation enabled 0 _B Deep adaptation disabled (default) 1 _B Deep adaptation enabled. Refer to Chapter 5.3.3.6
Reserved	13	rw	Reserved. This bits must be set to '0'
EN_GEN_CHECK	12	rw	Enable generator check 0 _B Detection of generator mode disabled (default) 1 _B Detection of generator mode enabled.
TPDCHG3	11:10	rw	Pre-discharge time of PWM channel 3 00 _B 125 ns (default) 01 _B 250 ns 10 _B 500 ns 11 _B 1000 ns
TPCHG3	9:8	rw	Pre-charge time of PWM channel 3 00 _B 125 ns (default) 01 _B 250 ns 10 _B 500 ns 11 _B 1000 ns
TPDCHG2	7:6	rw	Pre-discharge time of PWM channel 2 00 _B 125 ns (default) 01 _B 250 ns 10 _B 500 ns 11 _B 1000 ns
TPCHG2	5:4	rw	Pre-charge time of PWM channel 2 00 _B 125 ns (default) 01 _B 250 ns 10 _B 500 ns 11 _B 1000 ns
TPDCHG1	3:2	rw	Pre-discharge time of PWM channel 1 00 _B 125 ns (default) 01 _B 250 ns 10 _B 500 ns 11 _B 1000 ns

(table continues...)

(continued)

Field	Bits	Type	Description
TPCHG1	1:0	rw	Pre-charge time of PWM channel 1 00 _B 125 ns (default) 01 _B 250 ns 10 _B 500 ns 11 _B 1000 ns

8.1.2.4 Half-bridge diagnostic current control

HBIDIAG Address: 0 1001_B
Half-bridge diagnostic current control Reset value: 1100 0000 0000 0000_B

15	14	13	12	11	10	9	8	7	6	5	4	3	2	1	0
CSA2L	CSA1L	OC2FILT	OC1FILT	CSA2_OFF	CSA1_OFF	HB8I_DIAG	HB7I_DIAG	HB6I_DIAG	HB5I_DIAG	HB4I_DIAG	HB3I_DIAG	HB2I_DIAG	HB1I_DIAG		
rw	rw	rw	rw	rw	rw	rw	rw	rw	rw	rw	rw	rw	rw	rw	rw

Field	Bits	Type	Description
CSA2L	15	rw	Level of CSA2 0 _B CSA2 is configured as low-side 1 _B CSA2 is configured as high-side (default)
CSA1L	14	rw	Level of CSA1 0 _B CSA1 is configured as low-side 1 _B CSA1 is configured as high-side (default)
OC2FILT	13:12	rw	Overcurrent filter time for CSO2 00 _B 6 μs (default) 01 _B 10 μs 10 _B 50 μs 11 _B 100 μs
OC1FILT	11:10	rw	Overcurrent filter time for CSO1 00 _B 6 μs (default) 01 _B 10 μs 10 _B 50 μs 11 _B 100 μs
CSA2_OFF	9	rw	Disable of CSA2 0 _B CSA2 enabled(default) 1 _B CSA2 disabled
CSA1_OFF	8	rw	Disable of CSA1 0 _B CSA1 enabled (default) 1 _B CSA1 disabled

(table continues...)

(continued)

Field	Bits	Type	Description
HB8IDIAG	7	rw	Control of HB8 off-state current source and current sink 0 _B Pull-down deactivated (default) 1 _B Pull-down activated
HB7IDIAG	6	rw	Control of HB7 off-state current source and current sink 0 _B Pull-down deactivated (default) 1 _B Pull-down activated
HB6IDIAG	5	rw	Control of HB6 off-state current source and current sink 0 _B Pull-down deactivated (default) 1 _B Pull-down activated
HB5IDIAG	4	rw	Control of HB5 off-state current source and current sink 0 _B Pull-down deactivated (default) 1 _B Pull-down activated
HB4IDIAG	3	rw	Control of HB4 off-state current source and current sink 0 _B Pull-down deactivated (default) 1 _B Pull-down activated
HB3IDIAG	2	rw	Control of HB3 off-state current source and current sink 0 _B Pull-down deactivated (default) 1 _B Pull-down activated
HB2IDIAG	1	rw	Control of HB2 off-state current source and current sink 0 _B Pull-down deactivated (default) 1 _B Pull-down activated
HB1IDIAG	0	rw	Control of HB1 pull-down for off-state diagnostic 0 _B Pull-down deactivated (default) 1 _B Pull-down activated

8.1.2.5 Static charge and discharge current selection

Attention: This register is accessed only if `REG_BANK = 0` with the corresponding offset address.

ST_ICHG Address: 0 1010_B
Static charge and discharge current selection Reset value: 0000 0000 0100 0100_B

15	14	13	12	11	10	9	8	7	6	5	4	3	2	1	0
HB8IC	HB7I	HB6I	HB5I	HB4I	HB3I	HB2I	HB1I	ICHGST2				ICHGST1			
HGST	CHGS	CHGS	CHGS	CHGS	CHGS	CHGS	CHGS								
T	T	T	T	T	T	T	T								
rw	rw	rw	rw	rw	rw	rw	rw								

Field	Bits	Type	Description
HB8ICHGST	15	rw	HB8 Selection of charge and discharge currents 0_B The static charge/discharge current 1 is applied to the half-bridge 8 (default). 1_B The static charge/discharge current 2 is applied to the half-bridge 8.
HB7ICHGST	14	rw	HB7 Selection of charge and discharge currents 0_B The static charge/discharge current 1 is applied to the half-bridge 7 (default). 1_B The static charge/discharge current 2 is applied to the half-bridge 7.
HB6ICHGST	13	rw	HB6 Selection of charge and discharge currents 0_B The static charge/discharge current 1 is applied to the half-bridge 6 (default). 1_B The static charge/discharge current 2 is applied to the half-bridge 6.
HB5ICHGST	12	rw	HB5 Selection of charge and discharge currents 0_B The static charge/discharge current 1 is applied to the half-bridge 5 (default). 1_B The static charge/discharge current 2 is applied to the half-bridge 5.
HB4ICHGST	11	rw	HB4 Selection of charge and discharge currents 0_B The static charge/discharge current 1 is applied to the half-bridge 4 (default). 1_B The static charge/discharge current 2 is applied to the half-bridge 4.
HB3ICHGST	10	rw	HB3 Selection of charge and discharge currents 0_B The static charge/discharge current 1 is applied to the half-bridge 3 (default). 1_B The static charge/discharge current 2 is applied to the half-bridge 3.
HB2ICHGST	9	rw	HB2 Selection of charge and discharge currents 0_B The static charge/discharge current 1 is applied to the half-bridge 2 (default). 1_B The static charge/discharge current 2 is applied to the half-bridge 2.
HB1ICHGST	8	rw	HB1 Selection of charge and discharge currents 0_B The static charge/discharge current 1 is applied to the half-bridge 1 (default). 1_B The static charge/discharge current 2 is applied to the half-bridge 1.
ICHGST2	7:4	rw	Static gate driver charge and discharge currents 2 Refer to Table 10 Default: 0100_B - Charge 12.5 mA typ., discharge 14.2 mA typ.

(table continues...)

(continued)

Field	Bits	Type	Description
ICHGST1	3:0	rw	Static gate driver charge and discharge currents 1 Refer to Table 10 Default: 0100 _B - charge 12.5 mA typ., discharge 14.2 mA typ.

8.1.2.6 PWM Active MOSFET precharge current initialization

Attention: This register is accessed only if `REG_BANK = 1` with the corresponding offset address.

PWM_PCHG_INIT Address: 0 1010_B
Initial PWM precharge current selection Reset value: 0001 1000 1100 0110_B

15	14	13	12	11	10	9	8	7	6	5	4	3	2	1	0
Reser ved	PCHGINIT3				PCHGINIT2				PCHGINIT1						
r	rw				rw				rw						

Field	Bits	Type	Description
Reserved	15	r	Reserved. Always read as '0'
PCHGINIT3	14:10	rw	Initial precharge current of PWM Channel 3 Refer to Table 13 Default: 00110 _B ; typ. 8.0 mA
PCHGINIT2	9:5	rw	Initial precharge current of PWM Channel 2 Refer to Table 13 Default: 00110 _B ; typ. 8.0 mA
PCHGINIT1	4:0	rw	Initial precharge current of PWM Channel 1 Refer to Table 13 Default: 00110 _B ; typ. 8.0 mA

8.1.2.7 PWM charge current of active MOSFETs

Attention: This register is accessed with `REG_BANK = 0` and the offset address 0 1011B. The charge currents are applied to the active MOSFET (ICHG1-3).

PWM_ICHG_ACT Address: 0 1011_B
Active PWM charge current Reset value: 0001 1000 1100 0110_B

15	14	13	12	11	10	9	8	7	6	5	4	3	2	1	0
Reser ved	ICHG3				ICHG2				ICHG1						
r	rw				rw				rw						

Field	Bits	Type	Description
Reserved	15	r	Reserved. Always read as '0'
ICHG3	14:10	rw	Gate driver charge current of PWM Channel 3 (Active MOSFET) Refer to Table 13 Default: 00110 _B ; typ. 8.0 mA
ICHG2	9:5	rw	Gate driver charge current of PWM Channel 2 (Active MOSFET) Refer to Table 13 Default: 00110 _B ; typ. 8.0 mA
ICHG1	4:0	rw	Gate driver charge current of PWM Channel 1 (Active MOSFET) Refer to Table 13 Default: 00110 _B ; typ. 8.0 mA

8.1.2.8 PWM charge/discharge currents of FW MOSFETs

Attention: This register is accessed with `REG_BANK = 1` and the offset address `0 1011B`. The charge and discharge currents are applied to the freewheeling MOSFETs (ICHGFW1-3).

PWM_ICHG_FW Address: 0 1011_B
 FW PWM charge/discharge currents Reset value: 0001 1000 1100 0110_B

15	14	13	12	11	10	9	8	7	6	5	4	3	2	1	0
Reser ved	ICHG3_FW				ICHG2_FW				ICHG1_FW						
r	rw				rw				rw						

Field	Bits	Type	Description
Reserved	15	r	Reserved. Always read as '0'
ICHG3_FW	14:10	rw	Gate driver charge and discharge currents of PWM Channel 3 (FW MOSFET) Refer to Table 13 , Table 14 Default: 00110 _B . Typ. charge 8.0 mA, typ. discharge: 9.4 mA
ICHG2_FW	9:5	rw	Gate driver charge and discharge currents of PWM Channel 2 (FW MOSFET) Refer to Table 13 , Table 14 Default: 00110 _B . Typ. charge 8.0 mA, typ. discharge: 9.4 mA
ICHG1_FW	4:0	rw	Gate driver charge and discharge currents of PWM Channel 1 (FW MOSFET) Refer to Table 13 , Table 14 Default: 00110 _B . Typ. charge 8.0 mA, typ. discharge: 9.4 mA

Note: The selected currents are applied to the turn-on and the turn-off of the FW MOSFETs.

8.1.2.9 PWM discharge current for active MOSFETs

Attention: This register is accessed only if `REG_BANK = 0` with the corresponding offset address.

PWM_IDCHG_ACT Address: 0 1100_B
 PWM discharge current Reset value: 0001 1100 1110 0111_B

	15	14	13	12	11	10	9	8	7	6	5	4	3	2	1	0
CCSO	IDCHG3					IDCHG2					IDCHG1					
rw	rw					rw					rw					

Field	Bits	Type	Description
CCSO	15	rw	Capacitor connected to the current sense amplifier outputs 0 _B Capacitor connected to CSO < 100 pF (default) 1 _B Capacitor connected to CSO < 400 pF
IDCHG3	14:10	rw	Discharge current for PWM Channel 3 (Active MOSFET) Refer to Table 14 Default: 00111 _B ; typ. 11.8 mA
IDCHG2	9:5	rw	Discharge current for PWM Channel 2 (Active MOSFET) Refer to Table 14 Default: 00111 _B ; typ. 11.8 mA
IDCHG1	4:0	rw	Discharge current of PWM Channel 1 (Active MOSFET) Refer to Table 14 Default: 00111 _B ; typ. 11.8 mA

8.1.2.10 PWM Active MOSFET predischage current initialization

Attention: This register is accessed only if `REG_BANK = 1` with the corresponding offset address.

PWM_PDCHG_INIT Address: 0 1100_B
 Initial PWM predischage current selection Reset value: 0011 0001 1000 1100_B

	15	14	13	12	11	10	9	8	7	6	5	4	3	2	1	0
CCSO	PDCHGINIT3					PDCHGINIT2					PDCHGINIT1					
rw	rw					rw					rw					

Field	Bits	Type	Description
CCSO	15	rw	Capacitor connected to the current sense amplifier outputs 0 _B Capacitor connected to CSO < 100 pF (default) 1 _B Capacitor connected to CSO < 400 pF
PDCHGINIT3	14:10	rw	Initial predischage current of PWM Channel 3 Refer to Table 14 Default: 01100 _B ; typ. 26.0 mA

(table continues...)

(continued)

Field	Bits	Type	Description
PDCHGINIT2	9:5	rw	Initial pre-discharge current of PWM Channel 2 Refer to Table 14 Default: 01100 _B : typ. 26.0 mA
PDCHGINIT1	4:0	rw	Initial pre-discharge current of PWM Channel 1 Refer to Table 14 Default: 01100 _B : typ. 26.0 mA

8.1.2.11 PWM maximum drive current selection and active tCCP4, tBLANK 3/4

Attention: This register is accessed with `REG_BANK = 0` and the offset address `0 1101B`. `tCCP` and `tBLANK` are applicable to the active MOSFETs.

PWM_ICHGMAX_CCP_BLK3_ACT Address: 0 1101_B
 PWM max. drive current Reset value: 0100 1001 0000 0000_B

	15	14	13	12	11	10	9	8	7	6	5	4	3	2	1	0
Reserved	TBLANK4_ACT		TCCP4_ACT			TBLANK3_ACT			ICHGMAX3		ICHGMAX2		ICHGMAX1			
r	rw		rw			rw			rw		rw		rw			

Field	Bits	Type	Description
Reserved	15	r	Reserved. Always read as '0'
TBLANK4_ACT	14:12	rw	Blank time ¹⁾ - tBLANK4 Active Refer to Table 30 Default: 100 _B : typ. 2000 ns
TCCP4_ACT	11:9	rw	Cross-current protection ¹⁾ - tCCP4 Active Refer to Table 29 Default: 100 _B : typ. 2000 ns
TBLANK3_ACT	8:6	rw	Blank time ¹⁾ - tBLANK3 Active Refer to Table 30 Default: 100 _B : typ. 2000 ns
ICHGMAX3	5:4	rw	Maximum drive current of half-bridge mapped to PWM channel 3 during the pre-charge phase and pre-discharge phases ²⁾ 00 _B (default) charge: typ. 18.8 mA, discharge: typ. 19.7 mA 01 _B charge: typ. 41mA, discharge: typ. 43 mA 10 _B charge: typ. 77 mA, discharge: typ. 79 mA 11 _B charge: typ. 100 mA, discharge: typ. 100 mA

(table continues...)

(continued)

Field	Bits	Type	Description
ICHGMAX2	3:2	rw	Maximum drive current of half-bridge mapped to PWM channel 2 during the pre-charge phase and pre-discharge phases ²⁾ 00 _B (default) charge: typ. 18.8 mA, discharge: typ. 19.7 mA 01 _B charge: typ. 41 mA, discharge: typ. 43 mA 10 _B charge: typ. 77 mA, discharge: typ. 79 mA 11 _B charge: typ. 100 mA, discharge: typ. 100 mA
ICHGMAX1	1:0	rw	Maximum drive current of half-bridge mapped to PWM channel 1 during the pre-charge and pre-discharge phases ²⁾ 00 _B (default) charge: typ. 18.8 mA, discharge: typ. 19.7 mA 01 _B charge: typ. 41 mA, discharge: typ. 43 mA 10 _B charge: typ. 77 mA, discharge: typ. 79 mA 11 _B charge: typ. 100 mA, discharge: typ. 100 mA

1) Refer to [CCP_BLK1](#) for the mapping of (tCCPx,tBLANKx) to the half-bridges.

2) ICHGMAX is also the current applied during the post-charge of the PWM MOSFET Refer to [Table 12](#).

8.1.2.12 PWM maximum drive current selection and FW tCCP4, tBLANK 3/4

Attention: This register is accessed with [REG_BANK = 1](#) and the offset address 0 1101B. tCCP and tBLANK are applicable to the FW MOSFETs.

PWM_ICHGMAX_CCP_BLK3_FW Address: 0 1101_B
 PWM max. drive current Reset value: 0100 1001 0000 0000_B

15	14	13	12	11	10	9	8	7	6	5	4	3	2	1	0
Reserved	TBLANK4_FW			TCCP4_FW			TBLANK3_FW			ICHGMAX3	ICHGMAX2	ICHGMAX1			
r	rw			rw			rw			rw	rw	rw			

Field	Bits	Type	Description
Reserved	15	r	Reserved. Always read as '0'
TBLANK4_FW	14:12	rw	Blank time ¹⁾ - tBLANK4 Freewheeling Refer to Table 32 Default: 100B: typ. 2000 ns
TCCP4_FW	11:9	rw	Cross-current protection ¹⁾ - tCCP4 Freewheeling Refer to Table 31 Default: 100B: typ. 2000 ns
TBLANK3_FW	8:6	rw	Blank time ¹⁾ - tBLANK3 Freewheeling Refer to Table 32 Default: 100B: typ. 2000 ns

(table continues...)

(continued)

Field	Bits	Type	Description
ICHGMAX3	5:4	rw	Maximum drive current of half-bridge mapped to PWM channel 3 during the pre-charge phase and pre-discharge phases ²⁾ 00 _B (default) charge: typ. 19 mA, discharge: typ. 19 mA 01 _B charge: typ. 41mA, discharge: typ. 43 mA 10 _B charge: typ. 77 mA, discharge: typ. 79 mA 11 _B charge: typ. 100 mA, discharge: typ. 100 mA
ICHGMAX2	3:2	rw	Maximum drive current of half-bridge mapped to PWM channel 2 during the pre-charge phase and pre-discharge phases ²⁾ 00 _B (default) charge: typ. 19 mA, discharge: typ. 19 mA 01 _B charge: typ. 41mA, discharge: typ. 43 mA 10 _B charge: typ. 77 mA, discharge: typ. 79 mA 11 _B charge: typ. 100 mA, discharge: typ. 100 mA
ICHGMAX1	1:0	rw	Maximum drive current of half-bridge mapped to PWM channel 1 during the pre-charge and pre-discharge phases ²⁾ 00 _B (default) charge: typ. 19 mA, discharge: typ. 19 mA 01 _B charge: typ. 41mA, discharge: typ. 43 mA 10 _B charge: typ. 77 mA, discharge: typ. 79 mA 11 _B charge: typ. 100 mA, discharge: typ. 100 mA

1) Refer to [CCP_BLK1](#) for the mapping of (tCCPx,tBLANKx) to the half-bridges.

2) ICHGMAX is also the current applied during the post-charge of the PWM MOSFET Refer to [Table 12](#).

8.1.2.13 Selection MOSFET turn-on and turn-off delay for PWM channel 1

TDON_OFF1	Address:	0 1110 _B
MOSFET turn-on/off delay of PWM channel 1	Reset value:	0000 1010 0000 1010 _B
15 14 13 12 11 10 9 8 7 6 5 4 3 2 1 0		
TDOFF1	TDON1	
rw	rw	

Field	Bits	Type	Description
TDOFF1	15:8	rw	Turn-off delay time of PWM Channel 1. Typical TDOFF1 = 62.5 x TDOFF1[7:0] _D ns Default: 0000 1010 _B : 625 ns typ.
TDON1	7:0	rw	Turn-on delay time of PWM Channel 1. Typical TDON1 = 62.5 x TDON1[7:0] _D ns Default: 0000 1010 _B : 625 ns typ.

8.1.2.14 Selection MOSFET turn-on and turn-off delay for PWM channel 2

TDON_OFF2	Address:	0 1111 _B
MOSFET turn-on/off delay of PWM channel2	Reset value:	0000 1010 0000 1010 _B

8 Register specification

15	14	13	12	11	10	9	8	7	6	5	4	3	2	1	0
TDOFF2								TDON2							
rw								rw							

Field	Bits	Type	Description
TDOFF2	15:8	rw	Turn-off delay time of PWM Channel 2. Typical TDOFF2 = 62.5 x TDOFF2[7:0] _D ns Default: 0000 1010 _B : 625 ns typ.
TDON2	7:0	rw	Turn-on delay time of PWM Channel 2. Typical TDON2 = 62.5 x TDON2[7:0] _D ns Default: 0000 1010 _B : 625 ns typ.

8.1.2.15 Selection MOSFET turn-on and turn-off delay for PWM channel 3

TDON_OFF3 Address: 1 0000_B
MOSFET turn-on/off delay of PWM channel3 Reset value: 0000 1010 0000 1010_B

15	14	13	12	11	10	9	8	7	6	5	4	3	2	1	0
TDOFF3								TDON3							
rw								rw							

Field	Bits	Type	Description
TDOFF3	15:8	rw	Turn-off delay time of PWM Channel 3. Typical TDOFF3 = 62.5 x TDOFF3[7:0] _D ns Default: 0000 1010 _B : 625 ns typ.
TDON3	7:0	rw	Turn-on delay time of PWM Channel 3. Typical TDON3 = 62.5 x TDON3[7:0] _D ns Default: 0000 1010 _B : 625 ns typ.

8.2 Status register

Table 33 Register Overview

Register Short Name	Register Long Name	Offset Address	Reset Value
GENSTAT	General status register	11 _H	0 _H
DSOV	Drain-source overvoltage	12 _H	0 _H
HBVOUT_PWMERR	Half-Bridge output voltage	13 _H	0 _H
EFF_TDON_OFF1	Effective MOSFET turn-on and turn-off delays for PWM Channel 1	14 _H	0 _H
EFF_TDON_OFF2	Effective MOSFET turn-on and turn-off delays for PWM Channel 2	15 _H	0 _H
EFF_TDON_OFF3	Effective MOSFET turn-on and turn-off delays for PWM Channel 3	16 _H	0 _H
TRISE_FALL1	Effective MOSFET rise and fall times for PWM Channel 1	17 _H	0 _H
TRISE_FALL2	Effective MOSFET rise and fall times for PWM Channel 2	18 _H	0 _H
TRISE_FALL3	Effective MOSFET rise and fall times for PWM Channel 3	19 _H	0 _H
DEVID	Device identifier	1F _H	01 _H

8.2.1 General status register

GENSTAT **Address:** 1 0001_B
General Status Register **Reset value:** 0_B

15	14	13	12	11	10	9	8	7	6	5	4	3	2	1	0
PASS_VDSOV	WDMON	PWM_3STA_T	PWM_2STA_T	PWM_1STA_T	TDRE_G3	TDRE_G2	TDRE_G1	TSD	TW	OC2	OC1	VSOV	VSUV	CPUV	
r	r	r	r	r	rc	rc	rc	rc	rc	rc	rc	rc	rc	rc	rc

Field	Bits	Type	Description
PASS_VDSOV	15	r	DS overvoltage while the bridge driver is in passive mode 0 _B No overvoltage on drain-source of any low-sides (default) 1 _B Overvoltage on drain-source of one of the low-side is detected.
WDMON	14:13	r	Watchdog Monitoring 00 _B WD Timer is between [0%;25%[of the WD period (default) 01 _B WD Timer is between [25%;50%[of the WD period 10 _B WD Timer is between [50%;75%[of the WD period 11 _B WD Timer is between [75%;100 %[of the WD period

(table continues...)

(continued)

Field	Bits	Type	Description
PWM3STAT	12	r	Status of PWM3 input 0 _B PWM3 is low (default) 1 _B PWM3 is high
PWM2STAT	11	r	Status of PWM2 input 0 _B PWM2 is low (default) 1 _B PWM2 is high
PWM1STAT	10	r	Status of PWM1 input 0 _B PWM1 is low (default) 1 _B PWM1 is high
TDREG3	9	rc	PWM channel 3 - Regulation of turn-on and turn-off delays 0 _B the turn-on delay or the turn-off delay are not in regulation (default) 1 _B the turn-on and turn-off delays are in regulation
TDREG2	8	rc	PWM channel 2 - Regulation of turn-on and turn-off delays 0 _B the turn-on delay or the turn-off delay are not in regulation (default) 1 _B the turn-on and turn-off delays are in regulation
TDREG1	7	rc	PWM channel 1 - Regulation of turn-on and turn-off delays 0 _B the turn-on delay or the turn-off delay are not in regulation (default) 1 _B the turn-on and turn-off delays are in regulation
TSD	6	rc	Thermal Shutdown 0 _B No thermal shutdown is detected (default) 1 _B A thermal shutdown is detected ¹⁾
TW	5	rc	Thermal Warning 0 _B No thermal warning is detected (default) 1 _B A thermal warning is detected
OC2	4	rc	Overcurrent detection of CSO2 0 _B No overcurrent detection on CSO2 (default) 1 _B Overcurrent detected on CSO2 ²⁾
OC1	3	rc	Overcurrent detection of CSO1 0 _B No overcurrent detection on CSO1 (default) 1 _B Overcurrent detected on CSO1 ²⁾
VSOV	2	rc	VS Overvoltage 0 _B No overvoltage on V _S detected (default value) 1 _B Overvoltage on V _S detected ¹⁾
VSUV	1	rc	VS Undervoltage 0 _B No undervoltage on V _S detected (default value) 1 _B Undervoltage on V _S detected ¹⁾

(table continues...)

(continued)

Field	Bits	Type	Description
CPUV	0	rc	Charge Pump Undervoltage 0 _B No charge pump undervoltage (default) 1 _B A charge pump undervoltage is detected ¹⁾

1) The error is latched and the external MOSFETs are turned off.

2) The state of the external MOSFETs depends on the setting of OCEN bit (see [GENCTRL1](#)).

8.2.2 Drain-Source Overvoltage 1

DSOV Address: 1 0010_B

Drain-Source Overvoltage Reset value: 0_B

15	14	13	12	11	10	9	8	7	6	5	4	3	2	1	0
LS8D SOV	HS8D SOV	LS7D SOV	HS7D SOV	LS6D SOV	HS6D SOV	LS5D SOV	HS5D SOV	LS4D SOV	HS4D SOV	LS3D SOV	HS3D SOV	LS2D SOV	HS2D SOV	LS1D SOV	HS1D SOV
rc	rc	rc	rc	rc	rc	rc	rc	rc	rc	rc	rc	rc	rc	rc	rc

Field	Bits	Type	Description
LS8DSOV	15	rc	Drain-Source overvoltage on low-side 8 0 _B No overvoltage on drain-source of low-side 8 (default) 1 _B Overvoltage on drain-source of low-side 8 detected.
HS8DSOV	14	rc	Drain-Source overvoltage on high-side 8 0 _B No overvoltage on drain-source of high-side 8 (default) 1 _B Overvoltage on drain-source of high-side 8 detected.
LS7DSOV	13	rc	Drain-Source overvoltage on low-side 7 0 _B No overvoltage on drain-source of low-side 7 (default) 1 _B Overvoltage on drain-source of low-side 7 detected.
HS7DSOV	12	rc	Drain-Source overvoltage on high-side 7 0 _B No overvoltage on drain-source of high-side 7 (default) 1 _B Overvoltage on drain-source of high-side 7 detected.
LS6DSOV	11	rc	Drain-Source overvoltage on low-side 6 0 _B No overvoltage on drain-source of low-side 6 (default) 1 _B Overvoltage on drain-source of low-side 6 detected.
HS6DSOV	10	rc	Drain-Source overvoltage on high-side 6 0 _B No overvoltage on drain-source of high-side 6 (default) 1 _B Overvoltage on drain-source of high-side 6 detected.
LS5DSOV	9	rc	Drain-Source overvoltage on low-side 5 0 _B No overvoltage on drain-source of low-side 5 (default) 1 _B Overvoltage on drain-source of low-side 5 detected.
HS5DSOV	8	rc	Drain-Source overvoltage on high-side 5 0 _B No overvoltage on drain-source of high-side 5 (default) 1 _B Overvoltage on drain-source of high-side 5 detected.

(table continues...)

(continued)

Field	Bits	Type	Description
LS4DSOV	7	rc	Drain-Source overvoltage on low-side 4 0 _B No overvoltage on drain-source of low-side 4 (default) 1 _B Overvoltage on drain-source of low-side 4 detected.
HS4DSOV	6	rc	Drain-Source overvoltage on high-side 4 0 _B No overvoltage on drain-source of high-side 4 (default) 1 _B Overvoltage on drain-source of high-side 4 detected.
LS3DSOV	5	rc	Drain-Source overvoltage on low-side 3 0 _B No overvoltage on drain-source of low-side 3 (default) 1 _B Overvoltage on drain-source of low-side 3 detected.
HS3DSOV	4	rc	Drain-Source overvoltage on high-side 3 0 _B No overvoltage on drain-source of high-side 3 (default) 1 _B Overvoltage on drain-source of high-side 3 detected.
LS2DSOV	3	rc	Drain-Source overvoltage on low-side 2 0 _B No overvoltage on drain-source of low-side 2 (default) 1 _B Overvoltage on drain-source of low-side 2 detected.
HS2DSOV	2	rc	Drain-Source overvoltage on high-side 2 0 _B No overvoltage on drain-source of high-side 2 (default) 1 _B Overvoltage on drain-source of high-side 2 detected.
LS1DSOV	1	rc	Drain-Source overvoltage on low-side 1 0 _B No overvoltage on drain-source of low-side 1 (default) 1 _B Overvoltage on drain-source of low-side 1 detected.
HS1DSOV	0	rc	Drain-Source overvoltage on high-side 1 0 _B No overvoltage on drain-source of high-side 1 (default) 1 _B Overvoltage on drain-source of high-side 1 detected.

Note: The impacted MOSFET is latched off if a Drain-Source overvoltage is detected.

8.2.3 Half-bridge Output Voltage Status

HBVOUT_PWMERR **Address:** 1 0011_B
Half-bridge output voltage and PWM Error **Reset value:** 0_B

15	14	13	12	11	10	9	8	7	6	5	4	3	2	1	0
HB8P WME	HB7P WME	HB6P WME	HB5P WME	HB4P WME	HB3P WME	HB2P WME	HB1P WME	HB8V OUT	HB7V OUT	HB6V OUT	HB5V OUT	HB4V OUT	HB3V OUT	HB2V OUT	HB1V OUT
r	r	r	r	r	r	r	r	r	r	r	r	r	r	r	r

Field	Bits	Type	Description
HB8PWME	15	r	PWM Error on HB8 0 _B No PWM error (default) 1 _B More than one activated PWM channels is mapped to HB8 ¹⁾

(table continues...)

(continued)

Field	Bits	Type	Description
HB7PWME	14	r	PWM Error on HB7 0 _B No PWM error (default) 1 _B More than one activated PWM channels is mapped to HB7 ¹⁾
HB6PWME	13	r	PWM Error on HB6 0 _B No PWM error (default) 1 _B More than one activated PWM channels is mapped to HB6 ¹⁾
HB5PWME	12	r	PWM Error on HB5 0 _B No PWM error (default) 1 _B More than one activated PWM channels is mapped to HB5 ¹⁾
HB4PWME	11	r	PWM Error on HB4 0 _B No PWM error (default) 1 _B More than one activated PWM channels is mapped to HB4 ¹⁾
HB3PWME	10	r	PWM Error on HB3 0 _B No PWM error (default) 1 _B More than one activated PWM channels is mapped to HB3 ¹⁾
HB2PWME	9	r	PWM Error on HB2 0 _B No PWM error (default) 1 _B More than one activated PWM channels is mapped to HB2 ¹⁾
HB1PWME	8	r	PWM Error on HB1 0 _B No PWM error (default) 1 _B More than one activated PWM channels is mapped to HB1 ¹⁾
HB8VOUT	7	r	Voltage level at SH8 when HB8MODE[1:0] = (0,0) or (1,1): 0 _B Low: $ VDH - VSH8 > V_{VDSMONTHx}$ ²⁾ if HB8D = 0 $ VCSIN1 - VSH8 > V_{VDSMONTHx}$ if HB8D = 1 1 _B High: $ VDH - VSH8 < V_{VDSMONTHx}$ if HB8D = 0; $ VCSIN1 - VSH8 < V_{VDSMONTHx}$ if HB8D = 1 Note: $HB8VOUT = 0$ if HB8MODE[1:0] = (0,1) or (1,0)
HB7VOUT	6	r	Voltage level at SH7 when HB7MODE[1:0] = (0,0) or (1,1): 0 _B Low: $ VDH - VSH7 > V_{VDSMONTHx}$ ²⁾ if HB7D = 0 $ VCSIN1 - VSH7 > V_{VDSMONTHx}$ if HB7D = 1 1 _B High: $ VDH - VSH7 < V_{VDSMONTHx}$ if HB7D = 0; $ VCSIN1 - VSH7 < V_{VDSMONTHx}$ if HB7D = 1 Note: $HB7VOUT = 0$ if HB7MODE[1:0] = (0,1) or (1,0)
HB6VOUT	5	r	Voltage level at SH6 when HB6MODE[1:0] = (0,0) or (1,1): 0 _B Low: $ VDH - VSH6 > V_{VDSMONTHx}$ ²⁾ if HB6D = 0 $ VCSIN1 - VSH6 > V_{VDSMONTHx}$ if HB6D = 1 1 _B High: $ VDH - VSH6 < V_{VDSMONTHx}$ if HB6D = 0; $ VCSIN1 - VSH6 < V_{VDSMONTHx}$ if HB6D = 1 Note: $HB6VOUT = 0$ if HB6MODE[1:0] = (0,1) or (1,0)

(table continues...)

(continued)

Field	Bits	Type	Description
HB5VOUT	4	r	<p>Voltage level at SH5 when HB5MODE[1:0] = (0,0) or (1,1):</p> <p>0_B Low: $VDH - VSH5 > V_{VDSMONTHx}$²⁾ if HB5D = 0 $VCSIN1 - VSH5 > V_{VDSMONTHx}$ if HB5D = 1</p> <p>1_B High: $VDH - VSH5 < V_{VDSMONTHx}$ if HB5D = 0; $VCSIN1 - VSH5 < V_{VDSMONTHx}$ if HB5D = 1</p> <p>Note: $HB5VOUT = 0$ if HB5MODE[1:0] = (0,1) or (1,0)</p>
HB4VOUT	3	r	<p>Voltage level at SH4 when HB4MODE[1:0] = (0,0) or (1,1):</p> <p>0_B Low: $VDH - VSH4 > V_{VDSMONTHx}$²⁾ if HB4D = 0 $VCSIN1 - VSH4 > V_{VDSMONTHx}$ if HB4D = 1</p> <p>1_B High: $VDH - VSH4 < V_{VDSMONTHx}$ if HB4D = 0; $VCSIN1 - VSH4 < V_{VDSMONTHx}$ if HB4D = 1</p> <p>Note: $HB4VOUT = 0$ if HB4MODE[1:0] = (0,1) or (1,0)</p>
HB3VOUT	2	r	<p>Voltage level at SH3 when HB3MODE[1:0] = (0,0) or (1,1):</p> <p>0_B Low: $VDH - VSH3 > V_{VDSMONTHx}$²⁾ if HB3D = 0 $VCSIN1 - VSH3 > V_{VDSMONTHx}$ if HB3D = 1</p> <p>1_B High: $VDH - VSH3 < V_{VDSMONTHx}$ if HB3D = 0; $VCSIN1 - VSH3 < V_{VDSMONTHx}$ if HB3D = 1</p> <p>Note: $HB3VOUT = 0$ if HB3MODE[1:0] = (0,1) or (1,0)</p>
HB2VOUT	1	r	<p>Voltage level at SH2 when HB2MODE[1:0] = (0,0) or (1,1):</p> <p>0_B Low: $VDH - VSH2 > V_{VDSMONTHx}$²⁾ if HB2D = 0 $VCSIN1 - VSH2 > V_{VDSMONTHx}$ if HB2D = 1</p> <p>1_B High: $VDH - VSH2 < V_{VDSMONTHx}$ if HB2D = 0; $VCSIN1 - VSH2 < V_{VDSMONTHx}$ if HB2D = 1</p> <p>Note: $HB2VOUT = 0$ if HB2MODE[1:0] = (0,1) or (1,0)</p>
HB1VOUT	0	r	<p>Voltage level at SH1 when HB1MODE[1:0] = (0,0) or (1,1):</p> <p>0_B Low: $VDH - VSH1 > V_{VDSMONTHx}$²⁾ if HB1D = 0; $VCSIN1 - VSH1 > V_{VDSMONTHx}$ if HB1D = 1</p> <p>1_B High: $VDH - VSH1 < V_{VDSMONTHx}$ if HB1D = 0; $VCSIN1 - VSH1 < V_{VDSMONTHx}$ if HB1D = 1</p> <p>Note: $HB1VOUT = 0$ if HB1MODE[1:0] = (0,1) or (1,0)</p>

1) The bit is reset only if one PWM channel or no PWM channel is mapped to the half-bridge (refer to [PWMSET](#)).

2) $V_{VDSMONTHx}$ is the drain-source monitoring threshold selected for the corresponding half-bridge.

8.2.4 Effective MOSFET turn-on and turn-off delay of PWM1

EFF_TDON_OFF1 **Address:** 1 0100_B
 Effective MOSFET turn-on/off delay PWM1 **Reset value:** 0_B

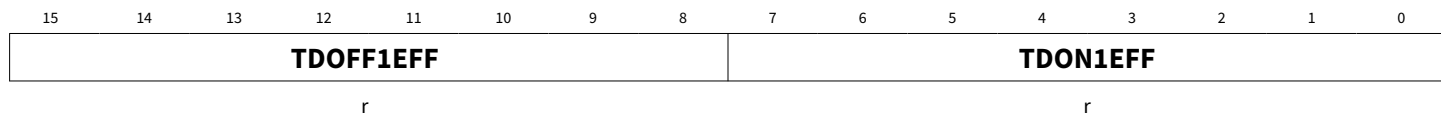

Field	Bits	Type	Description
TDOFF1EFF	15:8	r	Effective MOSFET turn-off delay of PWM Channel 1 Effective turn-off delay = 62.5 x TDOFF1EFF[7:0]D ns Default: 0 _B
TDON1EFF	7:0	r	Effective MOSFET turn-on delay of PWM Channel 1 Effective turn-on delay = 62.5 x TDON1EFF[7:0]D ns Default: 0 _B

8.2.5 Effective MOSFET turn-on and turn-off delay of PWM2

EFF_TDON_OFF2 **Address:** 1 0101_B
 Effective MOSFET turn-on/off delay PWM2 **Reset value:** 0_B

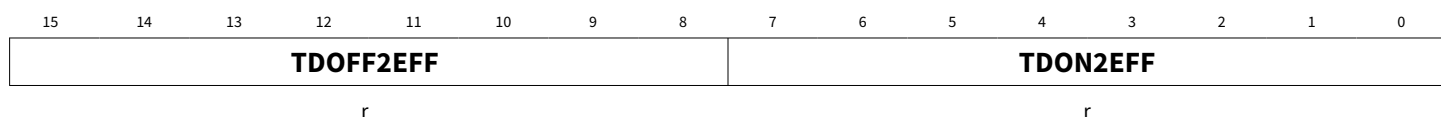

Field	Bits	Type	Description
TDOFF2EFF	15:8	r	Effective MOSFET turn-off delay of PWM Channel 2 Effective turn-off delay = 62.5 x TDOFF2EFF[7:0]D ns Default: 0 _B
TDON2EFF	7:0	r	Effective MOSFET turn-on delay of PWM Channel 2 Effective turn-on delay = 62.5 x TDON2EFF[7:0]D ns Default: 0 _B

8.2.6 Effective MOSFET turn-on and turn-off delay of PWM3

EFF_TDON_OFF3 **Address:** 1 0110_B
 Effective MOSFET turn-on/off delay PWM3 **Reset value:** 0_B

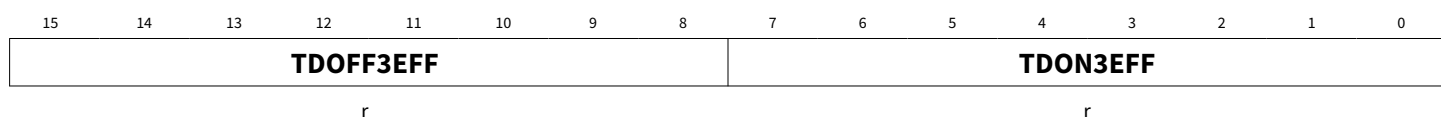

8 Register specification

Field	Bits	Type	Description
TDOFF3EFF	15:8	r	Effective MOSFET turn-off delay of PWM Channel 3 Effective turn-off delay = 62.5 x TDOFF3EFF[7:0] _D ns Default: 0 _B
TDON3EFF	7:0	r	Effective MOSFET turn-on delay of PWM Channel 3 Effective turn-on delay = 62.5 x TDON3EFF[7:0] _D ns Default: 0 _B

8.2.7 Effective MOSFET rise and fall times of PWM channel 1

TRISE_FALL1 Address: 1 0111_B
 Effective PWM MOSFET rise and fall times Reset value: 0_B
 PWM1

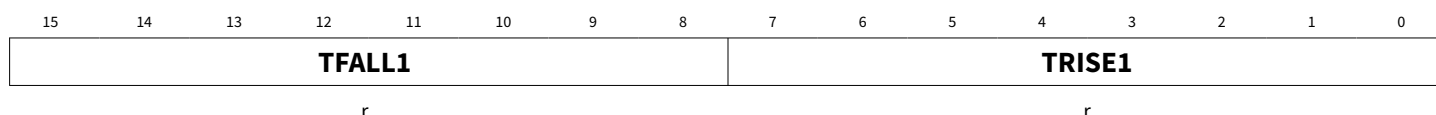

Field	Bits	Type	Description
TFALL1	15:8	r	MOSFET fall time of PWM Channel 1 MOSFET fall time = 62.5 x TFALL1[7:0] _D ns Default: 0 _B
TRISE1	7:0	r	MOSFET rise time of PWM Channel 1 MOSFET rise time = 62.5 x TRISE1[7:0] _D ns Default: 0 _B

8.2.8 Effective MOSFET rise and fall times of PWM channel 2

TRISE_FALL2 Address: 1 1000_B
 Effective PWM MOSFET rise and fall times Reset value: 0_B
 PWM2

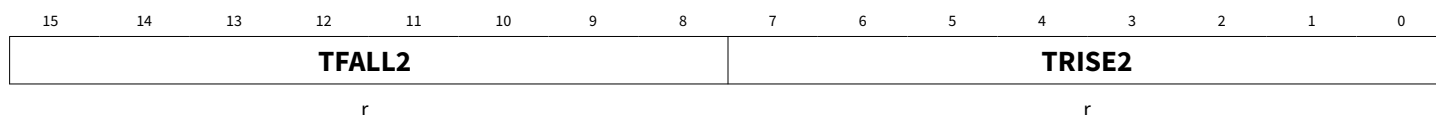

Field	Bits	Type	Description
TFALL2	15:8	r	MOSFET fall time of PWM Channel 2 MOSFET fall time = 62.5 x TFALL2[7:0] _D ns Default: 0 _B
TRISE2	7:0	r	MOSFET rise time of PWM Channel 2 MOSFET rise time = 62.5 x TRISE2[7:0] _D ns Default: 0 _B

8.2.9 Effective MOSFET rise and fall times of PWM channel 3

TRISE_FALL3 Address: 1 1001_B
 Effective PWM MOSFET rise and fall times Reset value: 0_B
 PWM3

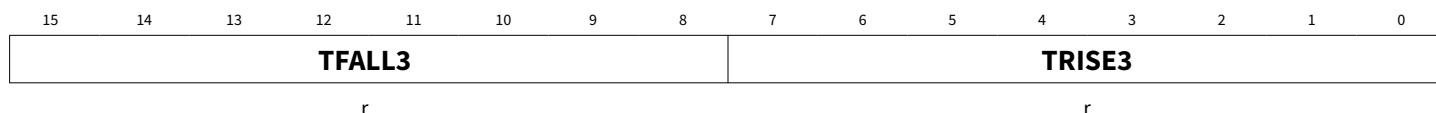

Field	Bits	Type	Description
TFALL3	15:8	r	MOSFET fall time of PWM Channel 3 MOSFET fall time = 62.5 x TFALL3[7:0] _D ns Default: 0 _B
TRISE3	7:0	r	MOSFET rise time of PWM Channel 3 MOSFET rise time = 62.5 x TRISE3[7:0] _D ns Default: 0 _B

8.2.10 Device Identifier

DEVID Address: 11111_B
 Device Identifier Reset value: 0000 0001_B

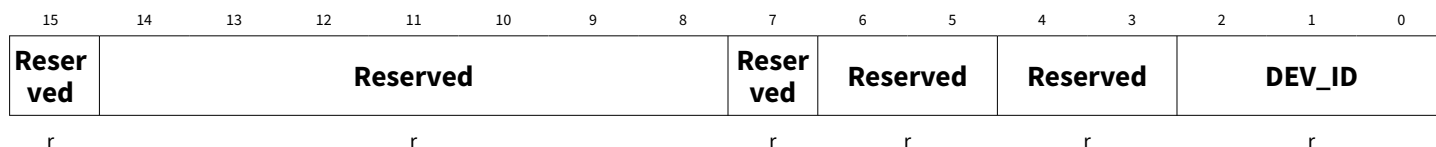

Field	Bits	Type	Description
Reserved	15	r	Reserved. Always read as '0'
Reserved	14:8	r	Reserved. Always read as '0'
Reserved	7	r	Reserved. Always read as '0'.
Reserved	6:5	r	Reserved.
Reserved	4:3	r	Reserved.
DEV_ID	2:0	r	Device derivative identifier 000 _B Reserved 001 _B TLE92108-232 010 _B Reserved 011 _B TLE92108-231 100 _B Reserved 101 _B Reserved 110 _B Reserved 111 _B Reserved

CCSOx must be between 10 pF and 400 pF. For a fast reaction time of the CSA output, it is recommended to keep CCSOx to 10 pF.

If a filter is used at the inputs of the current sense amplifier, the serial resistor may not exceed 5 Ω.

It is possible that the MOSFET gate voltage goes below the source voltage during the commutation of a half-bridge. This depends on the stray inductances at the drain and the source of the MOSFET, the speed of the commutation and the ratio between the MOSFET Gate-Source and Gate-Drain capacitances.

If $V_{GATE} - V_{SOURCE} < -0.6 \text{ V}$, a series resistor (e.g. 4.7 Ω) in series to GHx and GLx are recommended to limit current delivered by the gate driver during the commutation.

Shunt resistor in the motor phase

When the shunt resistor is placed in the motor phase, it is highly recommended to apply the PWM to the half-bridge which is not connected to the shunt resistor (Figure 51). This avoids a high common mode swing at the inputs of the current sense amplifier.

The drain-source monitoring of the monitoring of the drain-source overvoltage of the high-side MOSFETs must be set to DH - VSHx. Refer to VDS1, VDS2, HBxD bits.

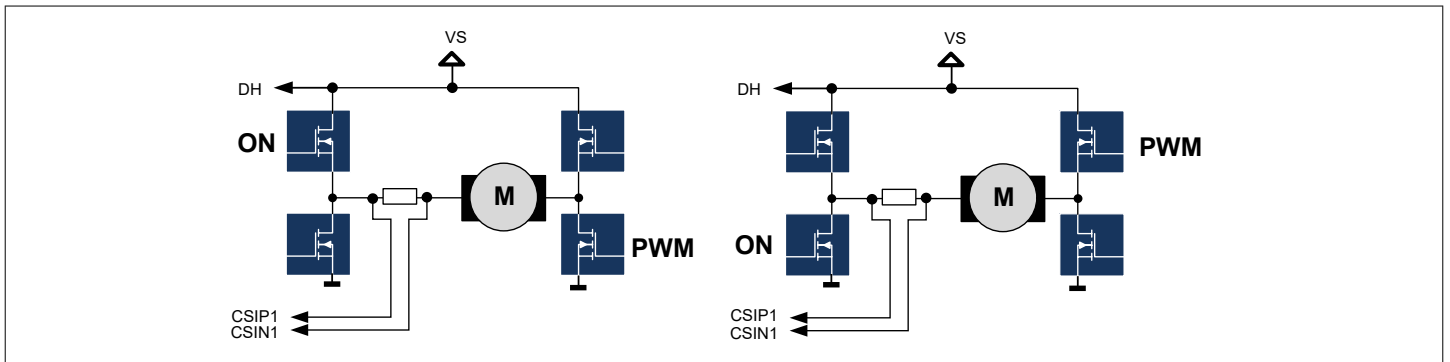

Figure 51 PWM with Shunt resistance in the motor phase

For a proper off-state diagnostic for with the shunt resistor in the motor phase, the corresponding current sense amplifier (CSA) must be deactivated. Otherwise, the activated CSA draws current from its inputs, preventing the internal pull-up source to set the SHx pin to high.

10 Package outlines

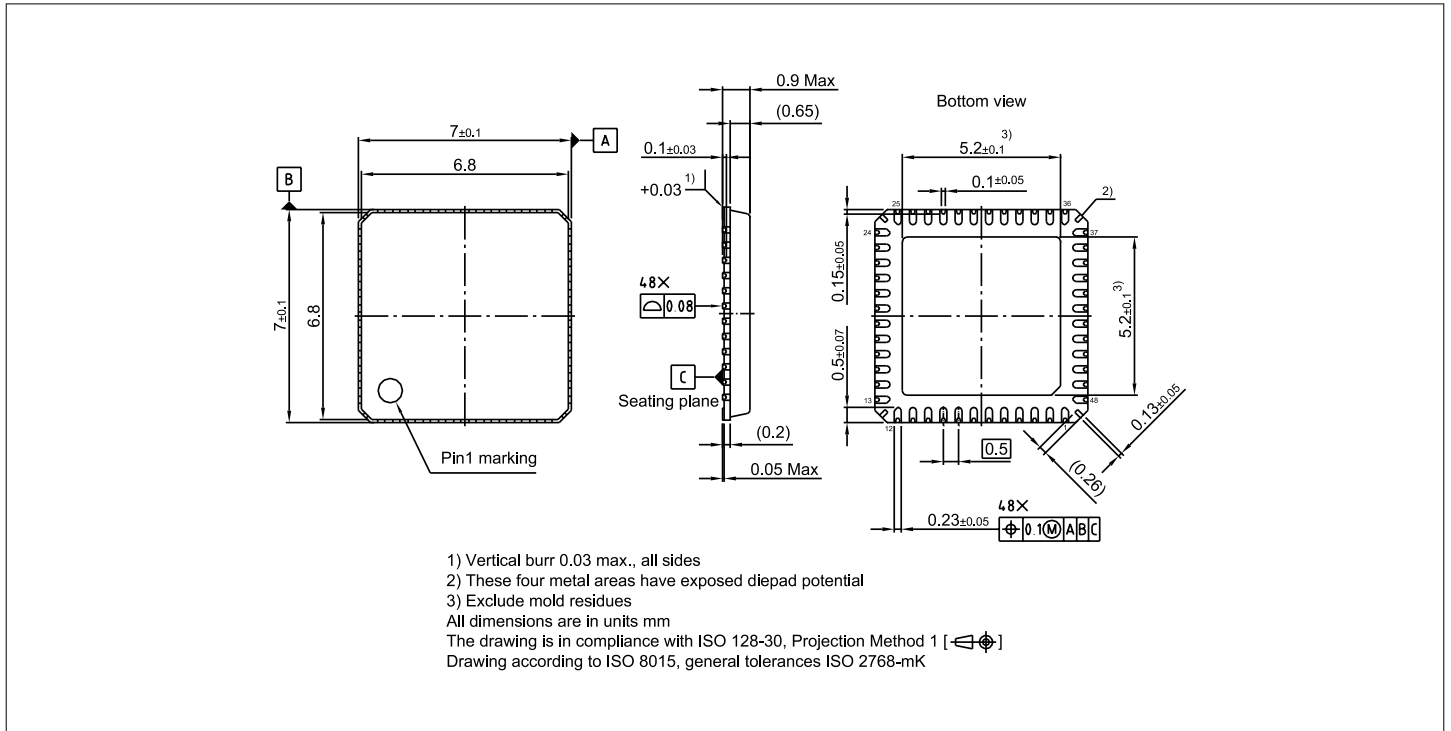

Figure 52 PG-VQFN-48-31 and PG-VQFN-48-37

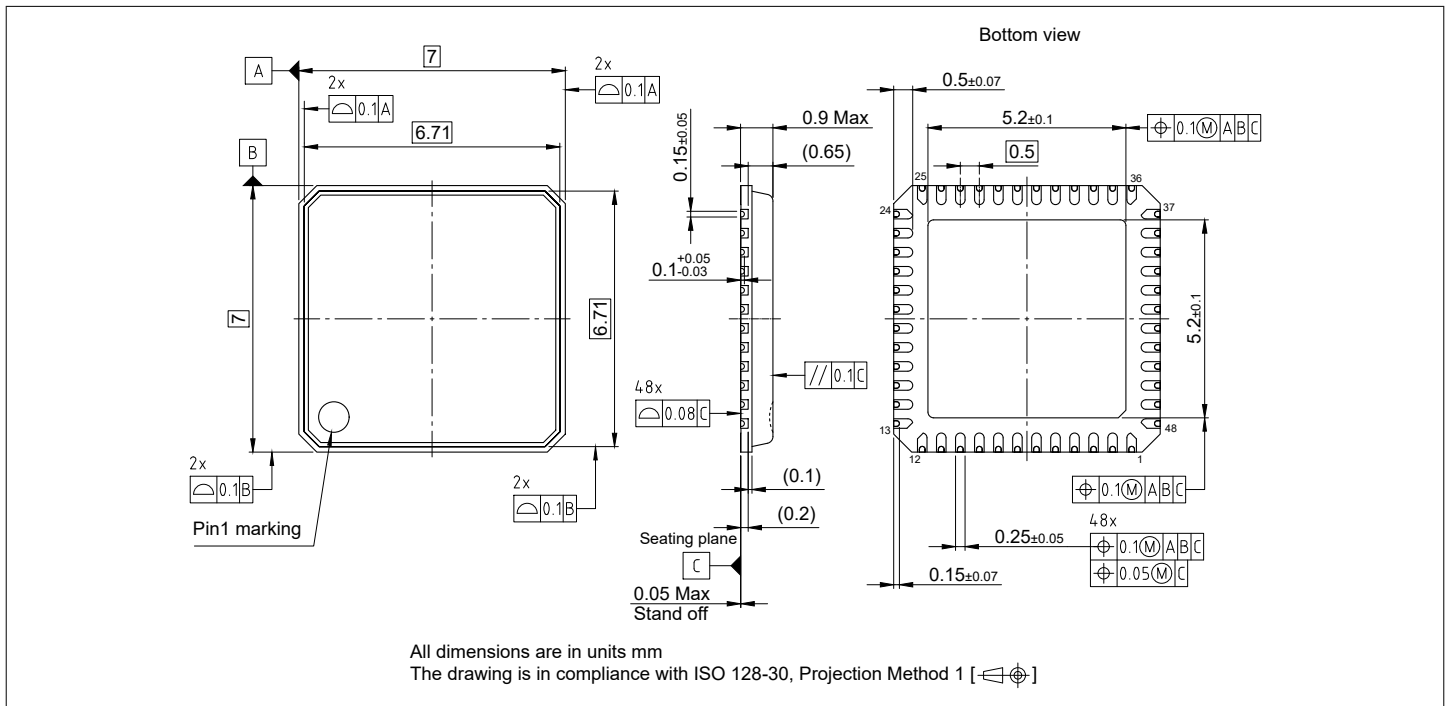

Figure 53 PG-VQFN-48-79

Green Product (RoHS compliant)

To meet the world-wide customer requirements for environmentally friendly products and to be compliant with government regulations the device is available as a green product. Green products are RoHS-Compliant (i.e Pb-free finish on leads and suitable for Pb-free soldering according to IPC/JEDEC J-STD-020).

11 Revision History

Revision	Date	Changes
2.0	2024-01-23	<ul style="list-style-type: none"> Additional package drawing in Chapter 10, with compatible footprint with the original package. P_7.11.70. Maximum passive turn-off time increased from 2 μs to 3.2 μs Chapter 6.3. Modified note for drain-source voltage monitoring in static activation Chapter 6.3. Note added drain-source voltage monitoring in PWM operation P_4.1.12. Absolute maximum rating of CP pin increased from VS + 15 V to VS + 17 V P_4.1.22, P_4.1.24. Absolute maximum rating of CPC1N, CPC2N, CPC1P, CPC2P is modified P_6.5.3 and P_6.5.6 – Max. gate-source high threshold value increased from 12 to 12.2 V Chapter 5.3.5 Deleted from the description for operation at low duty cycles: “The MOSFET opposite to the PWM MOSFET stays off(passive FW)” Package outline of Figure 52 updated Register bitmap template updated
1.0	2019-08-29	First release

Trademarks

All referenced product or service names and trademarks are the property of their respective owners.

Edition 2024-01-23

Published by

Infineon Technologies AG

81726 Munich, Germany

© 2025 Infineon Technologies AG

All Rights Reserved.

Do you have a question about any aspect of this document?

Email: erratum@infineon.com

Document reference

IFX-ugu1750753125120

Important notice

The information given in this document shall in no event be regarded as a guarantee of conditions or characteristics ("Beschaffheitsgarantie").

With respect to any examples, hints or any typical values stated herein and/or any information regarding the application of the product, Infineon Technologies hereby disclaims any and all warranties and liabilities of any kind, including without limitation warranties of non-infringement of intellectual property rights of any third party.

In addition, any information given in this document is subject to customer's compliance with its obligations stated in this document and any applicable legal requirements, norms and standards concerning customer's products and any use of the product of Infineon Technologies in customer's applications.

The data contained in this document is exclusively intended for technically trained staff. It is the responsibility of customer's technical departments to evaluate the suitability of the product for the intended application and the completeness of the product information given in this document with respect to such application.

Warnings

Due to technical requirements products may contain dangerous substances. For information on the types in question please contact your nearest Infineon Technologies office.

Except as otherwise explicitly approved by Infineon Technologies in a written document signed by authorized representatives of Infineon Technologies, Infineon Technologies' products may not be used in any applications where a failure of the product or any consequences of the use thereof can reasonably be expected to result in personal injury.