

## MOTIX™ TLE9191 gate driver IC for 48V/24V BLDC motors with phase cut off function

### Features

- High power 3-phase bridge driver for switching of six N-channel FETs with a  $Q_{Gtot}$  of 230 nC at a 20 kHz PWM
- Integrated functional independent phase-cut off high-side output stages (PCOx)
- Redundant phase-cut off supply pin VPCO
- Current source controlled output stages Gxx with adaptive MOSFET gate control
- 0...100% duty cycle, adjustable without restrictions
- Extended functional supply voltage range of 8 V to 70 V for a 24 V and 48 V battery supply systems
- High robustness of motor connection pins of -13 V to 110 V
- Three current sense amplifiers for low side shunt current measurement with high accuracy of 1% and fast settle time of 1  $\mu$ s
- Extended monitoring and diagnostic functions via serial peripheral interface (SPI)
- Support of self-test features
- SPI window watchdog for microcontroller supervision
- Configurable failure reactions including motor brake function
- High voltage rated digital input pins to microcontroller interface
- Developed according to ISO 26262 ASIL-D
- ISO 26262 safety element out of context for safety requirements up to ASIL D
- Safety manual available
- Passive clamping of external FETs
- Low quiescent current mode
- Optimized pinout for 24V/48V layout
- Green product (RoHS-compliant)
- Soldering: automated optical inspection capability (AOI)



### Potential applications

- 24 V and 48 V electric power steering (EPS)
- 24 V and 48 V electric brake booster (EBB)
- 24 V and 48 V functional safety related BLDC or PMSM motor drive applications

### Product validation

Product validation according to AEC-Q100, Grade 0. Qualified for automotive applications.

### Product description

The TLE9191 is a powerful gate driver for six N-channel power MOSFETs forming an inverter for 3-phase BLDC motors in the automotive applications. TLE9191 is addressing 24 V and 48 V battery voltage systems.

All low- and high-side output stages use current controlled gate driver concept and with 230 nC capable of driving a wide range of N-channel power MOSFETs. An adaptive MOSFET control concept allows to program the gate current sequence of each MOSFET in any desired way to optimize EMC and power dissipation performance. The device withstands voltages between -12 V and 110 V at motor phase related pins.

The individual switches are directly controlled via input pins allowing maximal flexibility for all kind of motor control schemes (for example FOC algorithm). Any duty cycle can be applied without restriction (0-100%). TLE9191 includes three current sense amplifiers to measure ground-based phase currents with high accuracy of 1% and fast settling time of 1  $\mu$ s.

An SPI interface is used to control and configure the TLE9191. The SPI is protected by cyclic redundancy check over data and address bits to secure a safe communication and data integrity.

The TLE9191 offers a wide range of diagnostic features, like monitoring of power supply voltages as well as system parameter monitoring. Failure behavior, threshold voltages and filter times of the supervisions of the device are fully adjustable via SPI.

TLE9191 provides configurable failure reaction modes, including the option to decelerate a spinning motor by turning on the low side MOSFETs.

**Product description**

The TLE9191 is especially designed for safety relevant motor drive applications and is developed according to the ISO 26262:2018 as a hardware safety element out of context with ASIL D. An optimized monitoring and diagnostic concept, including built-in self-test functions ensures high flexibility on fault reactions and low FIT rates for the relevant failure modes.

TLE9191 includes three independent phase cut-off output stages to control three external power MOSFETs in order to disconnect the phases from the motor.

TLE9191 is offered in VQFN 48 pin package with an exposed pad for an optimized thermal performance and provides special leads allowing an automated optical inspection.

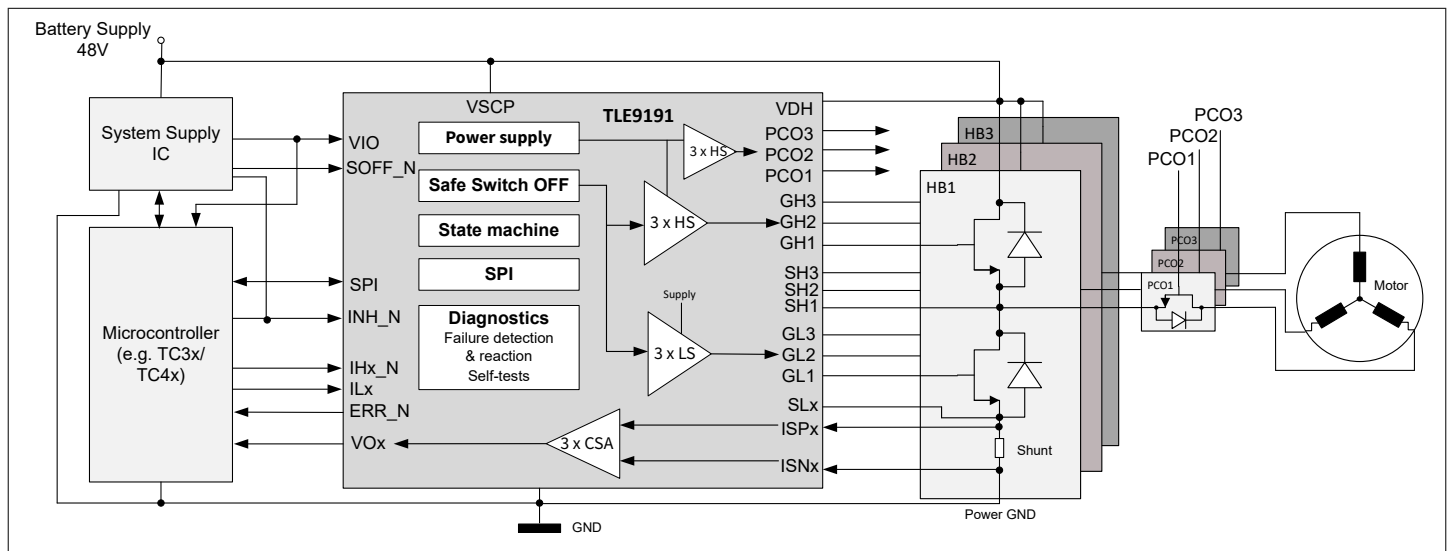

**Simplified application diagram**

Product type	Package	Marking
TLE9191	VQFN-48	TLE9191QVW

## Table of contents

	<b>Table of contents</b> .....	3
<b>1</b>	<b>Package</b> .....	4
	<b>Revision history</b> .....	5
	<b>Disclaimer</b> .....	6



## Revision history

<b>Document version</b>	<b>Date of release</b>	<b>Description of changes</b>
1.00	2026-03-26	Product overview available

## Trademarks

All referenced product or service names and trademarks are the property of their respective owners.

**Edition 2026-03-26**

**Published by**

**Infineon Technologies AG**

**81726 Munich, Germany**

**© 2026 Infineon Technologies AG**

**All Rights Reserved.**

**Do you have a question about any aspect of this document?**

**Email: [erratum@infineon.com](mailto:erratum@infineon.com)**

**Document reference**

**IFX-rxt1773737555646**

## Important notice

The information given in this document shall in no event be regarded as a guarantee of conditions or characteristics ("Beschaffheitsgarantie").

With respect to any examples, hints or any typical values stated herein and/or any information regarding the application of the product, Infineon Technologies hereby disclaims any and all warranties and liabilities of any kind, including without limitation warranties of non-infringement of intellectual property rights of any third party.

In addition, any information given in this document is subject to customer's compliance with its obligations stated in this document and any applicable legal requirements, norms and standards concerning customer's products and any use of the product of Infineon Technologies in customer's applications.

The data contained in this document is exclusively intended for technically trained staff. It is the responsibility of customer's technical departments to evaluate the suitability of the product for the intended application and the completeness of the product information given in this document with respect to such application.

## Warnings

Due to technical requirements products may contain dangerous substances. For information on the types in question please contact your nearest Infineon Technologies office.

Except as otherwise explicitly approved by Infineon Technologies in a written document signed by authorized representatives of Infineon Technologies, Infineon Technologies' products may not be used in any applications where a failure of the product or any consequences of the use thereof can reasonably be expected to result in personal injury.