

**Power PROFET™ + 24/48V smart high-side power switch**

**Features**

- PRO-SIL™ ISO 26262-ready for supporting the integrator in evaluation of hardware element according to ISO 26262:2018 Clause 8-13
- One channel device
- Low stand-by current
- Ground loss protection
- Electrostatic discharge protection (ESD)
- Optimized electromagnetic compatibility (EMC)
- Integrated diagnostic functions
- Integrated protection functions
- Green product (RoHS compliant)

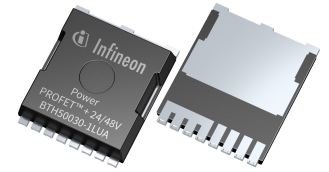

**Potential applications**

- Suitable for resistive, inductive and capacitive loads
- Replaces electromechanical relays, fuses and discrete circuits
- Most suitable for application with high current loads, such as heating system, fan and pump
- PWM applications with low frequency

**Product validation**

Qualified for Automotive Applications. Product Validation according to AEC-Q100 grade 1.

**Description**

The device is a 3.0 mΩ single channel smart high-side power switch, available in a PG-HSOF-8 package, providing protective functions and diagnosis. It is especially designed to drive high current loads, for applications like heaters, glow plugs, fans and pumps.

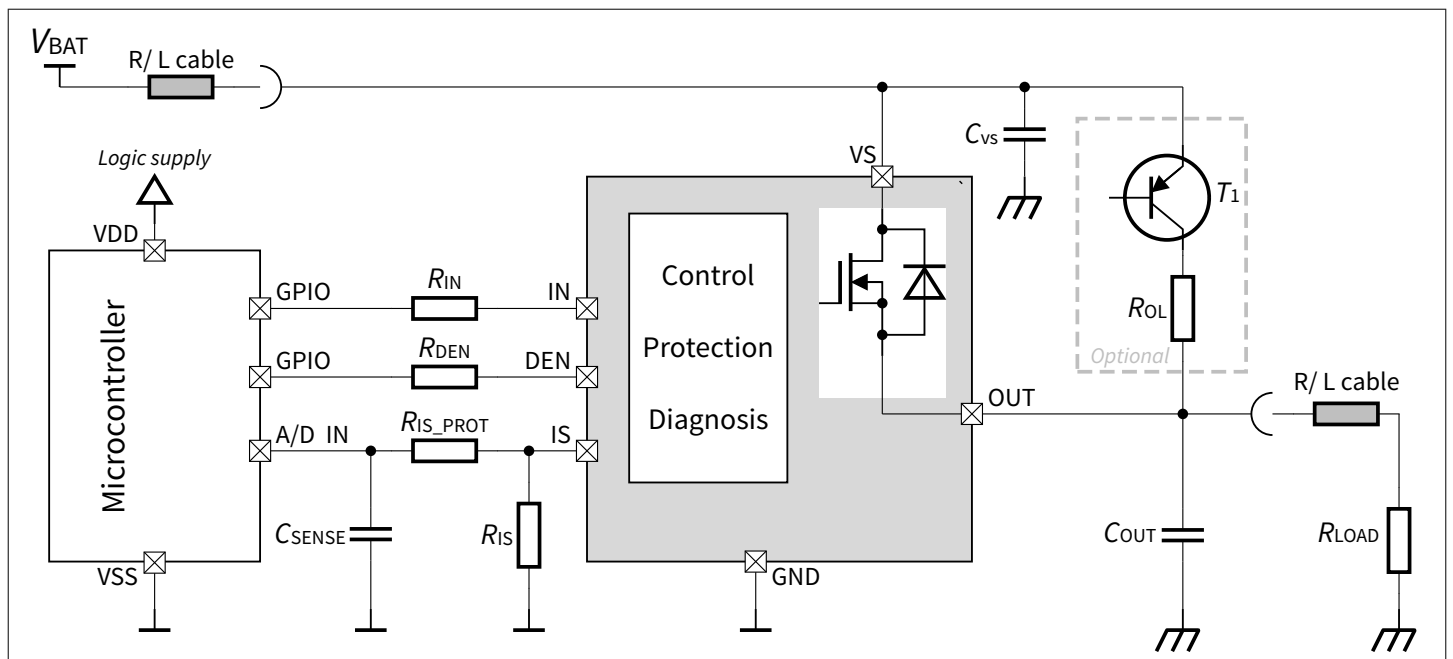

**Application diagram**

Type	Package	Marking
BTH50030-1LUA	PG-HSOF-8	H50030A

## Table of contents

	<b>Table of contents</b> .....	2
<b>1</b>	<b>Product description</b> .....	4
1.1	Product summary .....	4
1.2	Integrated diagnosis and protection functions .....	4
<b>2</b>	<b>Block diagram</b> .....	5
<b>3</b>	<b>Pin configuration</b> .....	6
<b>4</b>	<b>General product characteristics</b> .....	7
4.1	Absolute maximum ratings .....	7
4.2	Functional description .....	10
4.3	Thermal resistance .....	10
<b>5</b>	<b>Functional description</b> .....	12
5.1	Power stage .....	12
5.1.1	Output on-state resistance .....	12
5.1.2	Switching resistive loads .....	12
5.1.3	PWM switching .....	12
5.1.4	Switching inductive loads .....	13
5.1.4.1	Output clamping .....	13
5.1.4.2	Maximum load inductance .....	14
5.1.5	Advanced switch-off behavior .....	15
5.1.6	Inverse current behavior .....	15
5.2	Digital input pins: IN and DEN .....	16
5.3	Protection functions .....	16
5.3.1	Overload protection .....	17
5.3.1.1	Activation of the switch into short circuit (short circuit type 1) .....	17
5.3.1.2	Short circuit appearance when the device is already on (short circuit type 2) .....	17
5.3.1.3	Overpower shutdown (PSD) .....	17
5.3.1.4	Temperature limitation in the power MOSFET .....	18
5.3.2	Ground loss protection .....	18
5.4	Diagnosis functions .....	19
5.4.1	Overview .....	19
5.4.2	Diagnosis in on state .....	19
5.4.2.1	Sense signal variation and calibration .....	21
5.4.2.2	Sense signal timing .....	23
5.4.3	Diagnosis in off state .....	24
5.5	Electrical characteristics .....	25
<b>6</b>	<b>Typical performance characteristics</b> .....	31
<b>7</b>	<b>Application information</b> .....	36

<b>8</b>	<b>Package information</b> .....	<b>38</b>
<b>9</b>	<b>Revision history</b> .....	<b>39</b>
	<b>Disclaimer</b> .....	<b>40</b>

## 1 Product description

### 1.1 Product summary

**Table 1** Product summary

Parameter	Symbol	Values
Operating voltage	$V_{S(NOM)}$	12 V ... 54 V
Extended supply voltage range	$V_{S(EXT)}$	6 V ... 60 V
Maximum on-state resistance ( $T_J = 150\text{ °C}$ )	$R_{DS(ON)}$	7.0 m $\Omega$
Minimum nominal load current ( $T_A = 85\text{ °C}$ , 4-layer 2s2p PCB)	$I_{L(NOM)}$	22.5 A
Typical current sense ratio	$dk_{ILIS}$	34000
Minimum short circuit current threshold	$I_{CL(0)}$	55 A
Maximum stand-by current at $T_J = 25\text{ °C}$	$I_{VS(OFF\_L)}$	7 $\mu$ A

### 1.2 Integrated diagnosis and protection functions

#### Integrated diagnosis functions

- Proportional load current sense
- Open load detection in on and off state
- Diagnosis enable pin
- Latched status signal after short circuit or overtemperature detection

#### Integrated protection functions

- Short circuit protection with latch
- Overtemperature protection with latch
- Enhanced short circuit operation
- Smart clamping for inductive loads demagnetization

## 2 Block diagram

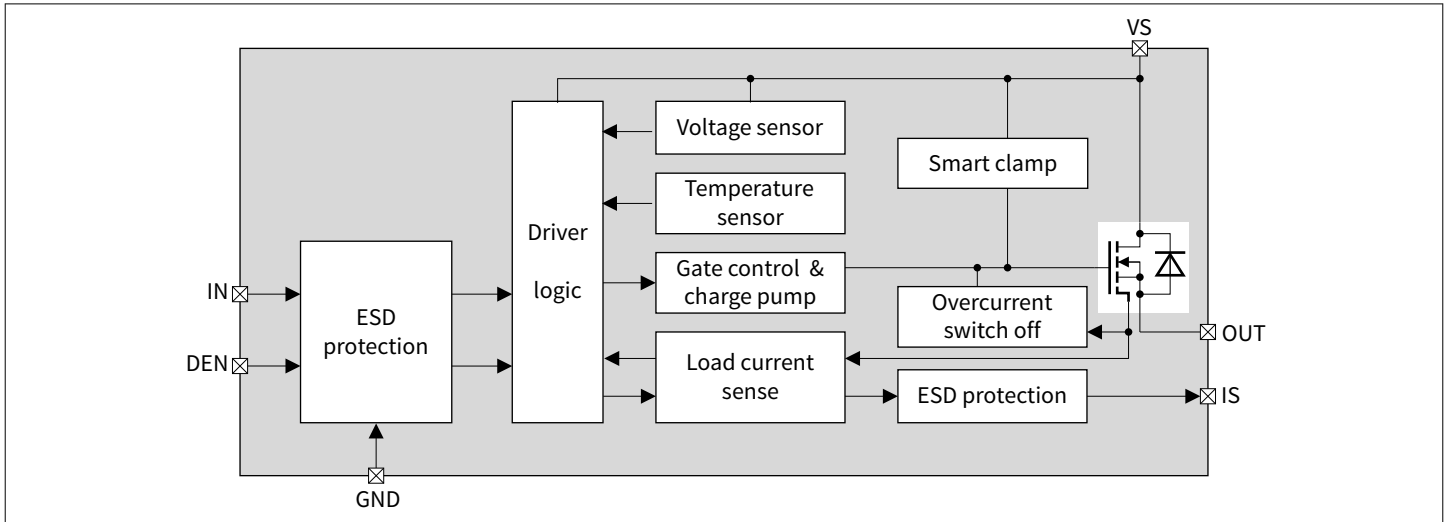

Figure 2 Block diagram

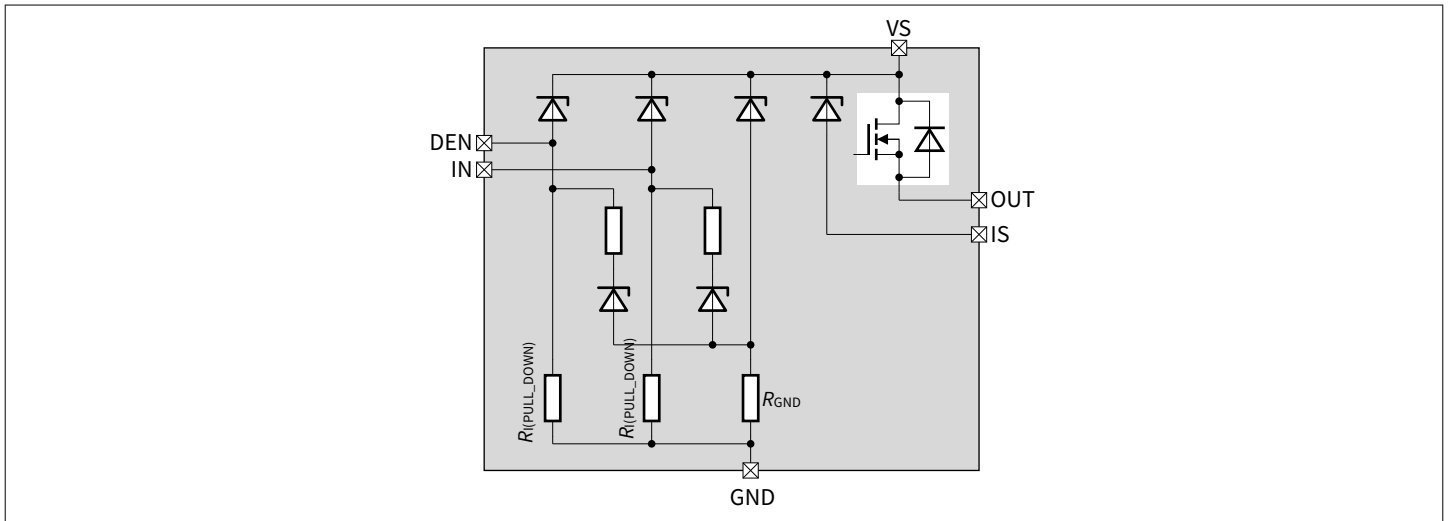

Figure 3 Internal diodes diagram

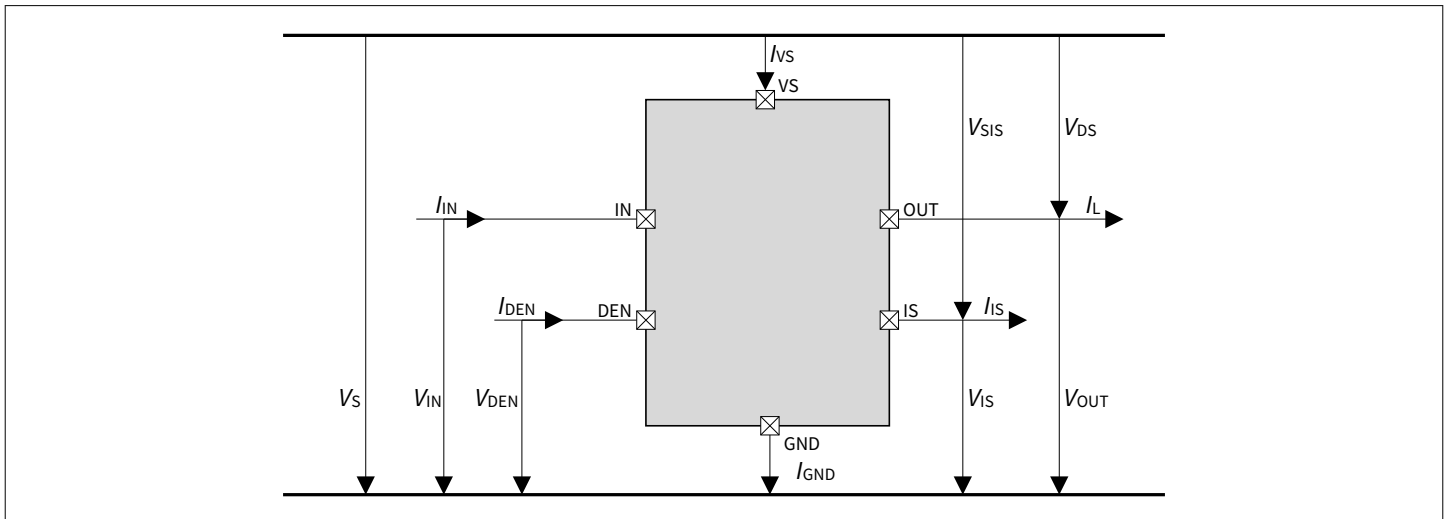
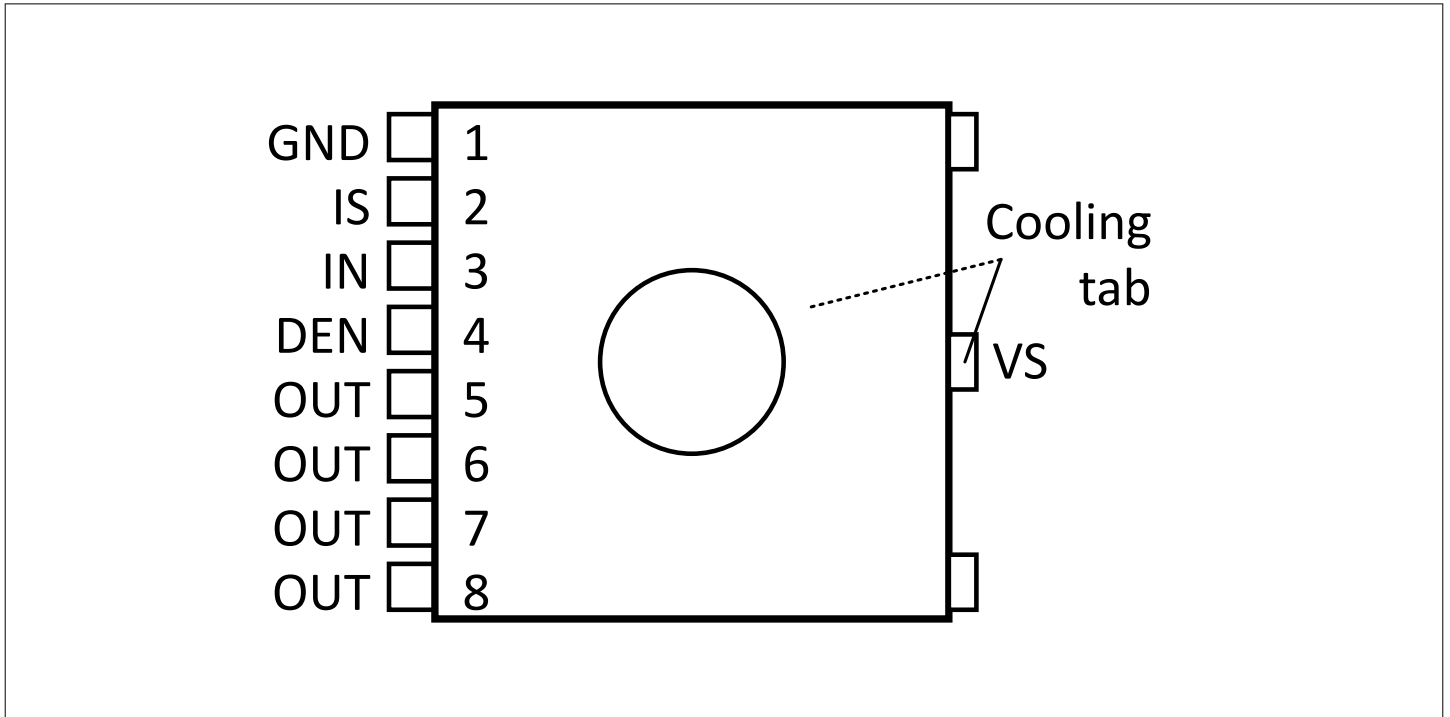

Figure 4 Voltage and current definition

### 3 Pin configuration



**Figure 5** Pin assignment

**Table 2** Pin definitions and function

Pin	Symbol	Function
1	GND	Ground pin
2	IS	Sense pin: analog/digital signal for diagnosis, if not used: left open
3	IN	Input pin: digital signal to switch on the output (active high)
4	DEN	Diagnosis enable pin: digital signal to enable the diagnosis (active high)
5, 6, 7, 8	OUT	Output pin: single protected high side power output
Cooling tab	VS	Supply voltage: battery voltage

## 4 General product characteristics

### 4.1 Absolute maximum ratings

**Table 3 Absolute maximum ratings**

$T_J = -40^{\circ}\text{C}$  to  $+150^{\circ}\text{C}$ ; all voltages with respect to ground, positive current flowing into pin (unless otherwise specified)

Parameter	Symbol	Values			Unit	Note or condition	P-Number
		Min.	Typ.	Max.			

#### Supply voltages

Supply voltage	$V_S$	-0.3	-	70	V	<sup>1)</sup>	PRQ-32
Short term overvoltage	$V_{S(STO)}$	-	-	70	V	<sup>1)</sup> Short term overvoltage according to ISO 21780:2020(E), test-03 $R_L = R_{L(NOM)}$ $R_{IS} = 2 \text{ k}\Omega$	PRQ-34

#### Short circuit capability

Supply voltage for short circuit protection	$V_{S(SC)}$	6	-	36	V	<sup>1)</sup> According to the test circuit defined in figure 1 of AEC Q100-012, with $L_{SUPPLY} = 1$ to $15 \mu\text{H}$ and $L_{SHORT} = 0$ to $15 \mu\text{H}$	PRQ-381
Supply voltage for short circuit protection	$V_{S(SC)}$	36	-	54	V	<sup>1)</sup> According to the test circuit defined in figure 1 of AEC Q100-012, with $L_{SUPPLY} = 1$ to $5 \mu\text{H}$ and $L_{SHORT} = 0$ to $5 \mu\text{H}$	PRQ-384
Supply voltage for short circuit protection	$V_{S(SC)}$	54	-	60	V	<sup>1)</sup> According to the test circuit defined in figure 1 of AEC Q100-012, with $L_{SUPPLY} + L_{SHORT} = 1$ to $5 \mu\text{H}$	PRQ-35

#### Input pin (IN)

Voltage at IN pin	$V_{IN}$	$V_S - 75$	-	$V_S + 0.3$	V	<sup>1)</sup>	PRQ-36
Current through IN pin	$I_{IN}$	-50	-	50	mA	<sup>1)</sup>	PRQ-37
Maximum input frequency	$f_{IN}$	-	-	100	Hz	<sup>1)</sup> $V_S$ in $V_{S(EXT)}$ range	PRQ-38
Maximum retry cycle rate in fault condition	$f_{FAULT}$	-	-	100	Hz	<sup>1)</sup>	PRQ-39

#### Diagnosis enable pin (DEN)

Voltage at DEN pin	$V_{DEN}$	$V_S - 75$	-	$V_S + 0.3$	V	<sup>1)</sup>	PRQ-40
--------------------	-----------	------------	---	-------------	---	---------------	--------

(table continues...)

**Table 3 (continued) Absolute maximum ratings**

$T_J = -40^\circ\text{C}$  to  $+150^\circ\text{C}$ ; all voltages with respect to ground, positive current flowing into pin (unless otherwise specified)

Parameter	Symbol	Values			Unit	Note or condition	P-Number
		Min.	Typ.	Max.			
Current through DEN pin	$I_{\text{DEN}}$	-50	-	50	mA	<sup>1)</sup>	PRQ-41

**Sense and diagnosis pin (IS)**

Voltage at IS pin	$V_{\text{IS}}$	$V_S - 75$	-	$V_S + 0.3$	V	<sup>1)</sup>	PRQ-42
Current through IS pin	$I_{\text{IS}}$	-50	-	50	mA	<sup>1)</sup>	PRQ-43

**Power stage**

Maximum energy dissipation by switching off inductive load single pulse over lifetime	$E_{\text{AS}}$	-	-	175	mJ	<sup>1)</sup> $I_L = 17\text{ A}$ , $T_{J(0)} \leq 150^\circ\text{C}$	PRQ-313
Maximum energy dissipation repetitive pulse	$E_{\text{AR}}$	-	-	100	mJ	<sup>1)</sup> $I_L = 17\text{ A}$ , $T_{J(0)} \leq 105^\circ\text{C}$ , 1 million cycles See <a href="#">Figure 6</a>	PRQ-314
Voltage at OUT pin	$V_S - V_{\text{OUT}}$	-0.3	-	70	V	<sup>1)</sup>	PRQ-46

**Temperatures**

Junction temperature	$T_J$	-40	-	150	$^\circ\text{C}$	<sup>1)</sup>	PRQ-47
Dynamic temperature increase while switching	$\Delta T_J$	-	-	60	K	<sup>1)</sup>	PRQ-48
Storage temperature	$T_{\text{STG}}$	-55	-	150	$^\circ\text{C}$	<sup>1)</sup>	PRQ-49

**ESD susceptibility**

ESD susceptibility (all pins)	$V_{\text{ESD(HBM)}}$	-2	-	2	kV	<sup>1)</sup> Human Body Model "HBM" according to the AEC Q100-002	PRQ-50
ESD susceptibility OUT vs GND and VS connected	$V_{\text{ESD(HBM)}}$	-4	-	4	kV	<sup>1)</sup> Human Body Model "HBM" according to the AEC Q100-002	PRQ-51
ESD susceptibility (all pins)	$V_{\text{ESD(CDM)}}$	-500	-	500	V	<sup>1)</sup> Charge Device Model "CDM" according to AEC Q100-11	PRQ-52
ESD susceptibility (corner pins)	$V_{\text{ESD(CDM)}}$	-750	-	750	V	<sup>1)</sup> Charge Device Model "CDM" according to AEC Q100-11	PRQ-53

<sup>1)</sup> Not subject to production test, specified by design.

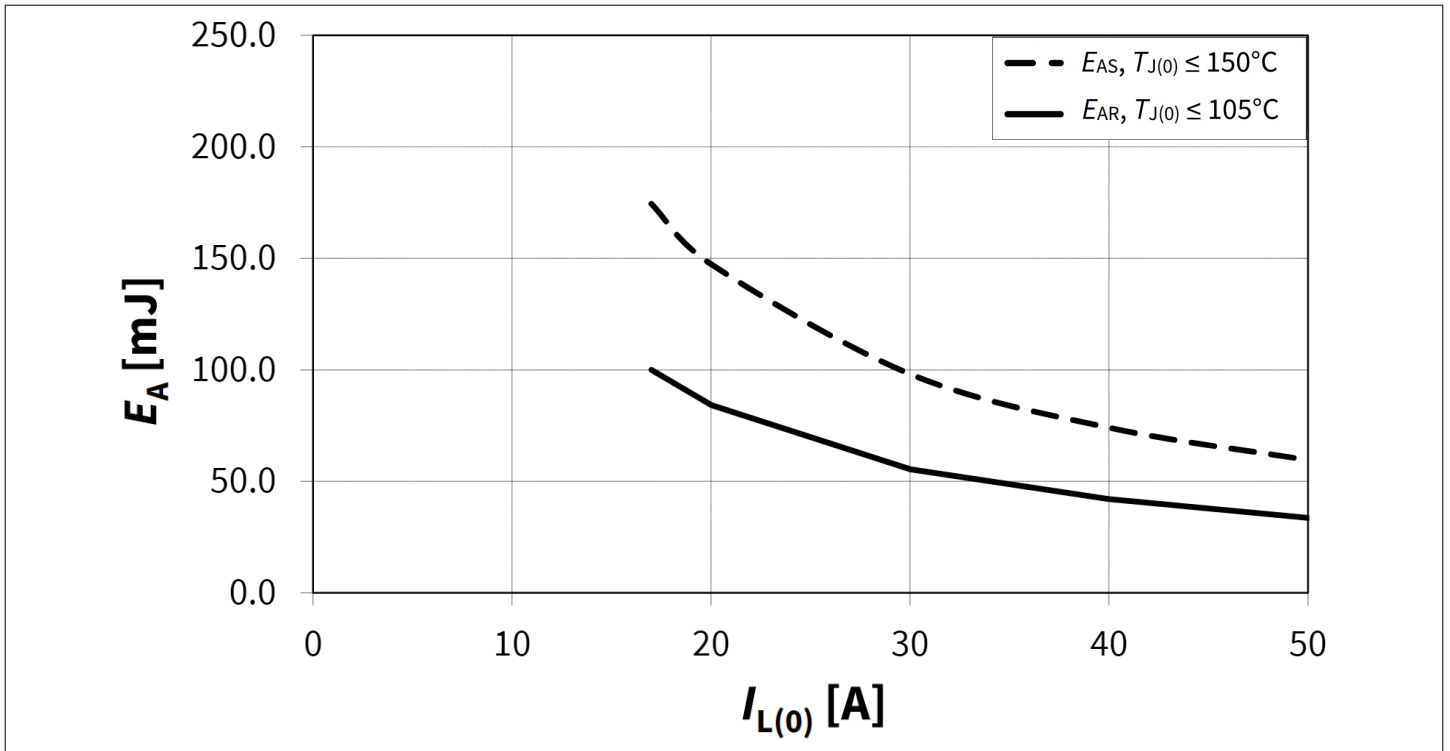

**Figure 6** Maximum energy dissipation for inductive switch off,  $E_{AS/AR}$  vs.  $I_L$

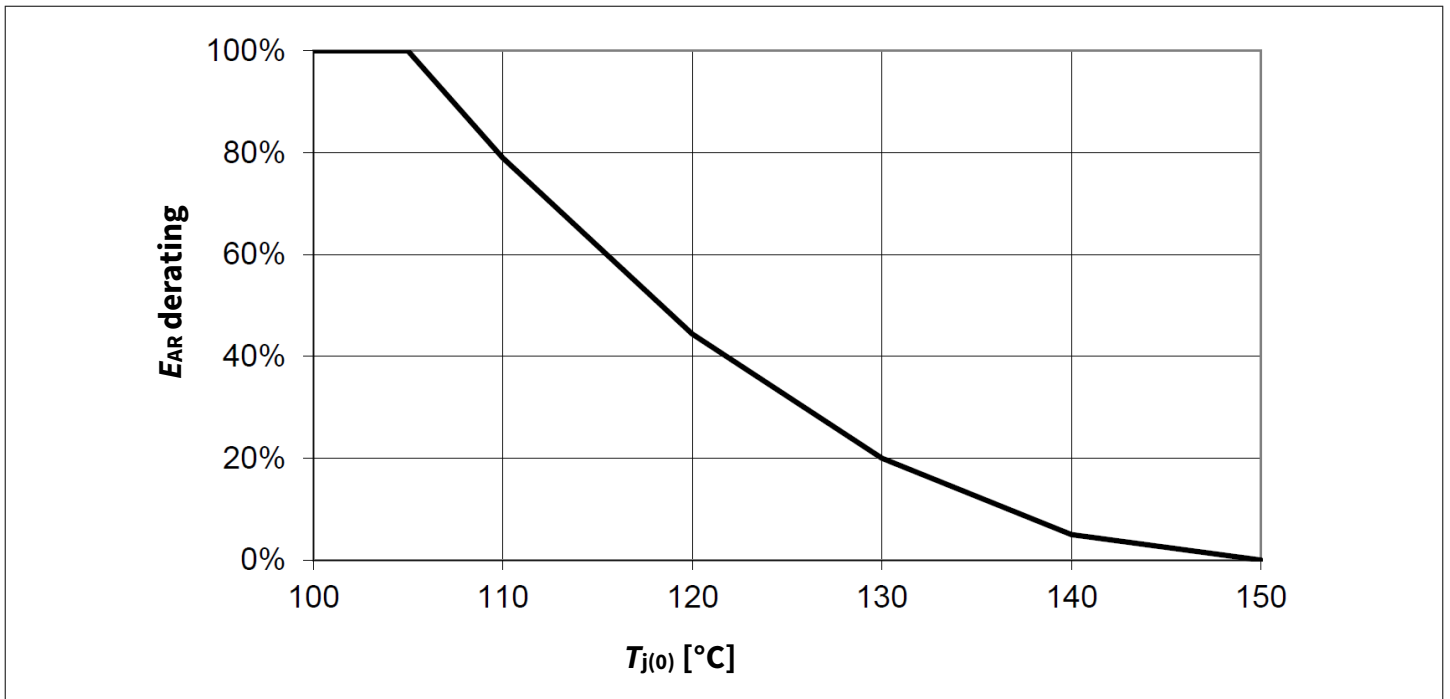

**Figure 7** Maximum energy dissipation repetitive pulse temperature derating

**Note:**

1. Stresses above the ones listed here may cause permanent damage to the device. Exposure to absolute maximum rating conditions for extended periods may affect device reliability.
2. Integrated protection functions are designed to prevent IC destruction under fault conditions described in the data sheet. Fault conditions are considered as “outside” normal operating range. Protection functions are not designed for continuous repetitive operation.

## 4.2 Functional description

**Table 4** Functional range

Parameter	Symbol	Values			Unit	Note or condition	P-Number
		Min.	Typ.	Max.			
Supply voltage range for nominal operation	$V_{S(NOM)}$	12	–	54	V	1)	PRQ-54
Supply voltage range for extended operation	$V_{S(EXT)}$	6	–	60	V	1)2) Parameter deviation possible	PRQ-55
Nominal load resistor	$R_{L(NOM)}$	–	2.8	–	$\Omega$	1)	PRQ-299
Condition for accurate current measurement	$Min(V_S - V_{IS})$	–	–	8	V	1)	PRQ-312

1) Not subject to production test, specified by design.

2) Protection function still operative

**Note:** Within the nominal operating range, the IC behaves as described in the circuit description. The electrical characteristics are inside the limits specified in the Electrical Characteristics table.

## 4.3 Thermal resistance

**Note:** This thermal data was generated in accordance to JEDEC JESD51 standards. For more information, go to [www.jedec.org](http://www.jedec.org).

**Table 5** Thermal resistance

Parameter	Symbol	Values			Unit	Note or condition	P-Number
		Min.	Typ.	Max.			
Junction to case	$R_{thJC}$	–	–	0.6	K/W	1)	PRQ-300
Junction to ambient	$R_{thJA(2s2p)}$	–	18	–	K/W	1) 2)	PRQ-301
Junction to ambient	$R_{thJA(1s0p)}/600mm^2$	–	32	–	K/W	1) 3)	PRQ-302

1) Not subject to production test, specified by design.

2) Specified  $R_{thJA}$  value is according to Jedec JESD51-2,-5,-7 at natural convection on FR4 2s2p board; the product (chip + package) was simulated on a  $76.2 \times 114.3 \times 1.5$  mm board with 2 inner copper layers ( $2 \times 70 \mu m$  Cu,  $2 \times 35 \mu m$  Cu). Where applicable a thermal via array under the exposed pad contacted the first inner copper layer. Simulation done at  $T_A = 105^\circ C$ . The device is dissipating 2 W power.

3) Specified  $R_{thJA}$  value is according to Jedec JESD51-2,-5,-7 at natural convection on FR4 1s0p board; the product (chip + package) was simulated on a  $76.2 \times 114.3 \times 1.5$  mm board with only one top copper layer  $1 \times 70 \mu m$ . Simulation done at  $T_A = 105^\circ C$ . The device is dissipating 2 W power.

Figure 8 is showing the typical thermal impedance of BTH50030-1LUA mounted according to JEDEC JESD51-2,-5,-7 at natural convection on FR4 1s0p and 2s2p boards.

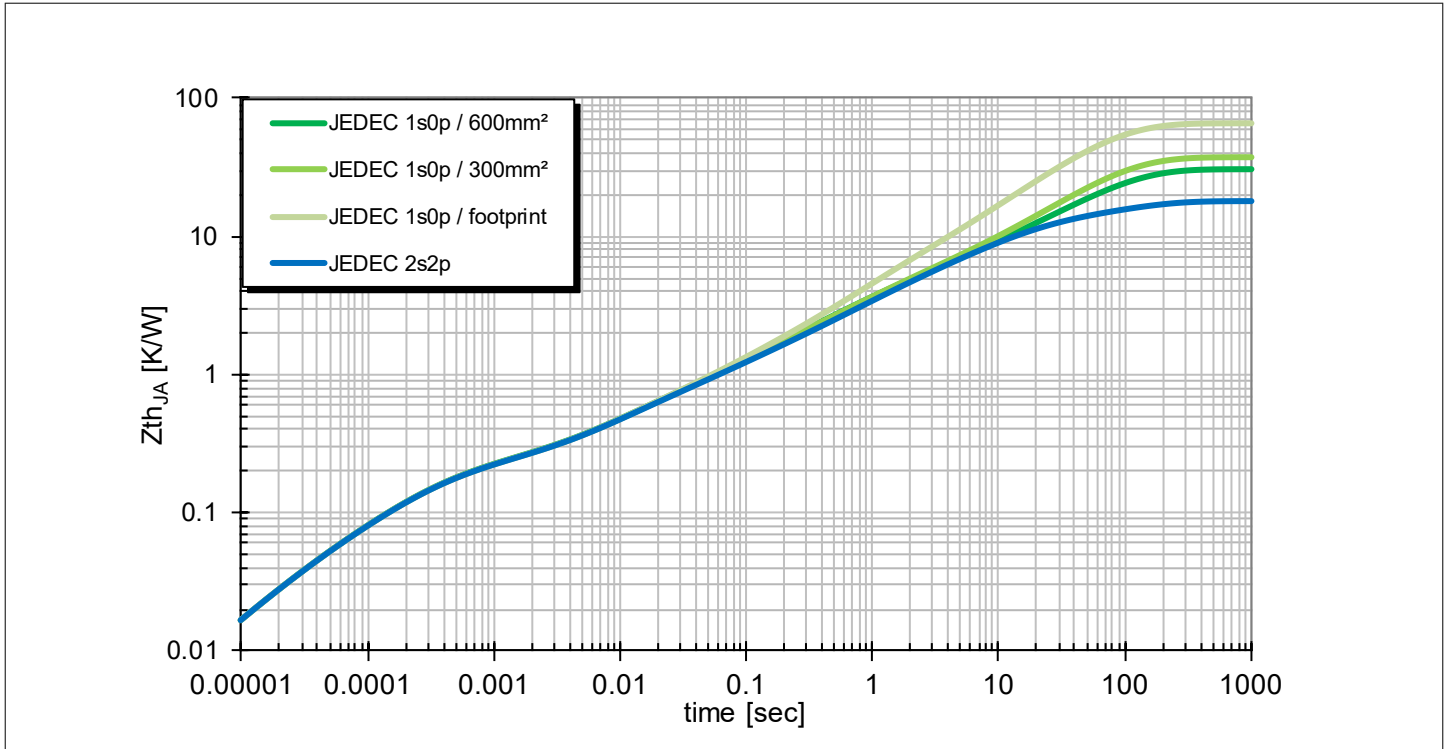

Figure 8 Typical transient thermal impedance  $Z_{th(JA)} = f(\text{time})$  for different PCB conditions

## 5 Functional description

### 5.1 Power stage

The power stage is built by a N-channel power MOSFET with a charge pump.

#### 5.1.1 Output on-state resistance

The on-state resistance  $R_{DS(ON)}$  depends on the supply voltage and on the junction temperature  $T_J$ . Chapter 6 shows the dependencies in terms of temperature and supply voltage, for the typical on-state resistance.

#### 5.1.2 Switching resistive loads

Figure 9 shows the typical timing when switching a resistive load. The power stage has a defined switching behavior. Defined slew rates results in lowest EMC emission at minimum switching losses.

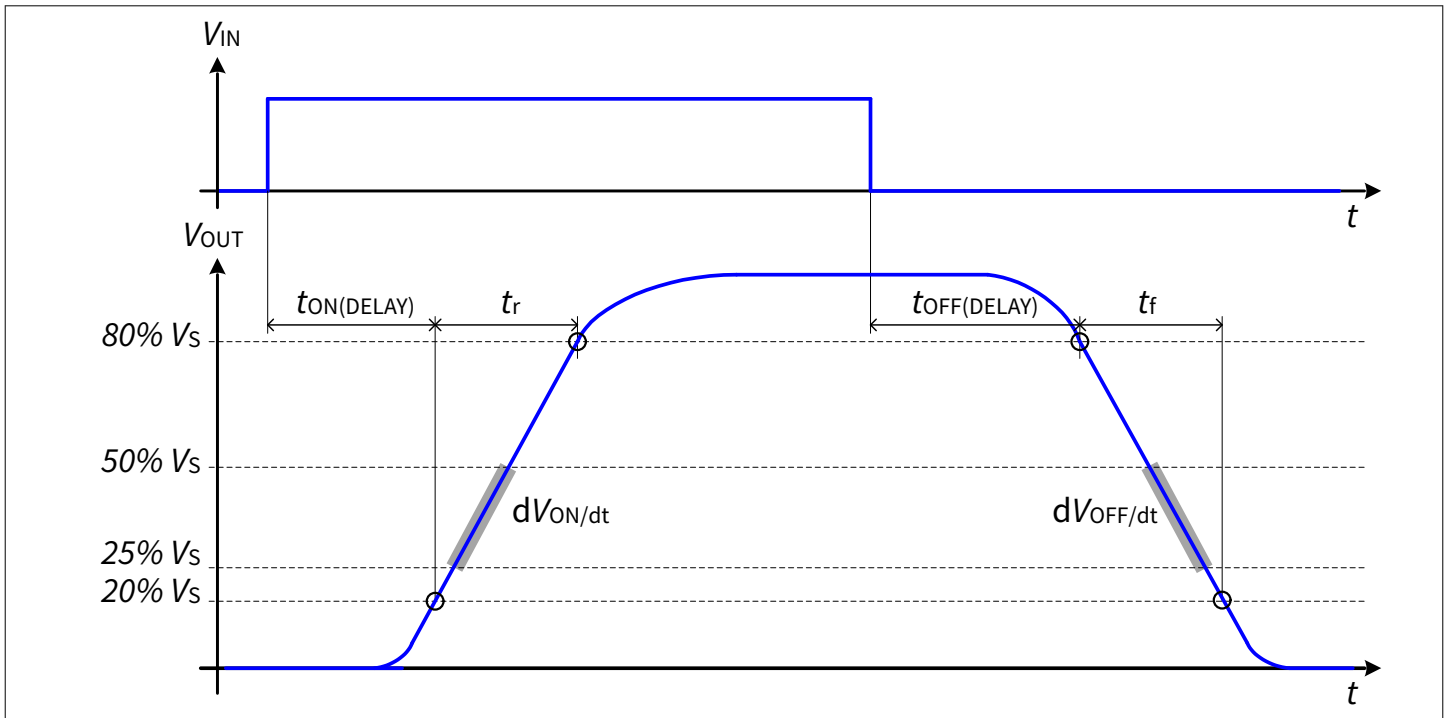

**Figure 9** Timings when switching a resistive load

#### 5.1.3 PWM switching

Consider the switching losses properly during this operation (see following equation):

$$P_{TOTAL} = \frac{switch\_on\_energy + switch\_of\_energy + (I_L^2 \times R_{DS(ON)} \times t_{DC})}{Period} \quad (1)$$

If a fault condition occurs, ensure that the PWM frequency does not exceed a maximum retry frequency of  $f_{FAULT}$ .

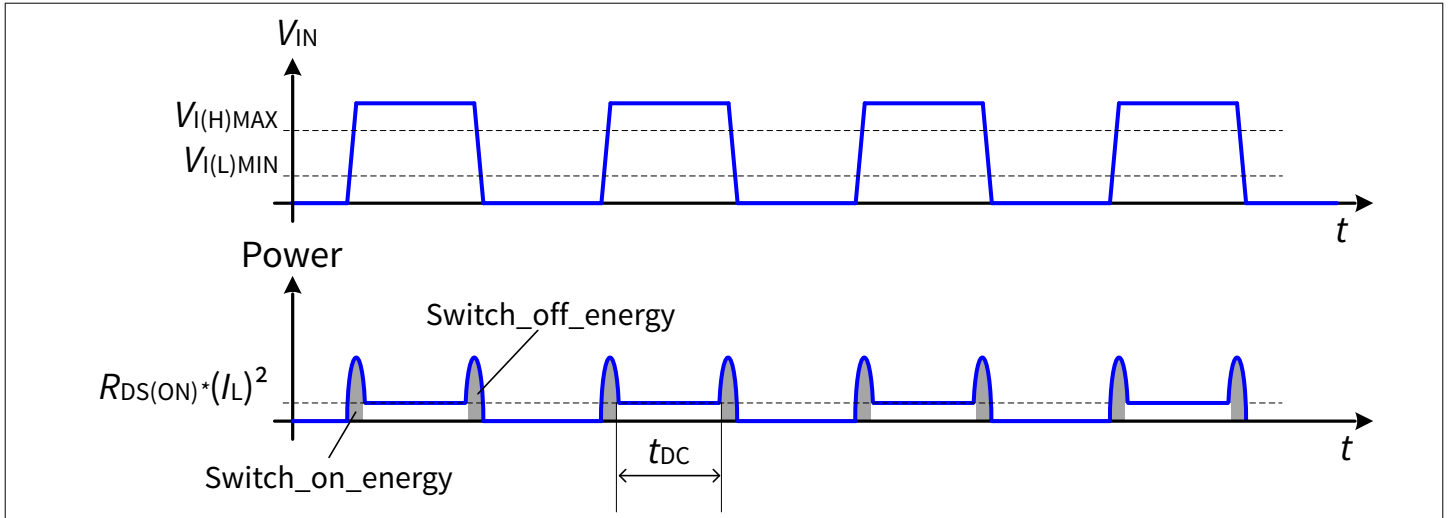

**Figure 10** Switching in PWM

### 5.1.4 Switching inductive loads

#### 5.1.4.1 Output clamping

When switching off inductive loads with high-side switches, the voltage  $V_{OUT}$  drops below ground potential, since the voltage polarity across the inductor has to be reversed to get a decrease of the inductive load current.

To prevent the destruction of the device due to high voltages, there is a smart clamping mechanism implemented that keeps negative output voltage to a certain level ( $V_S - V_{DS(CL)}$ ). Please refer to [Figure 11](#) and [Figure 12](#) for details. Nevertheless, the maximum allowed load inductance remains limited.

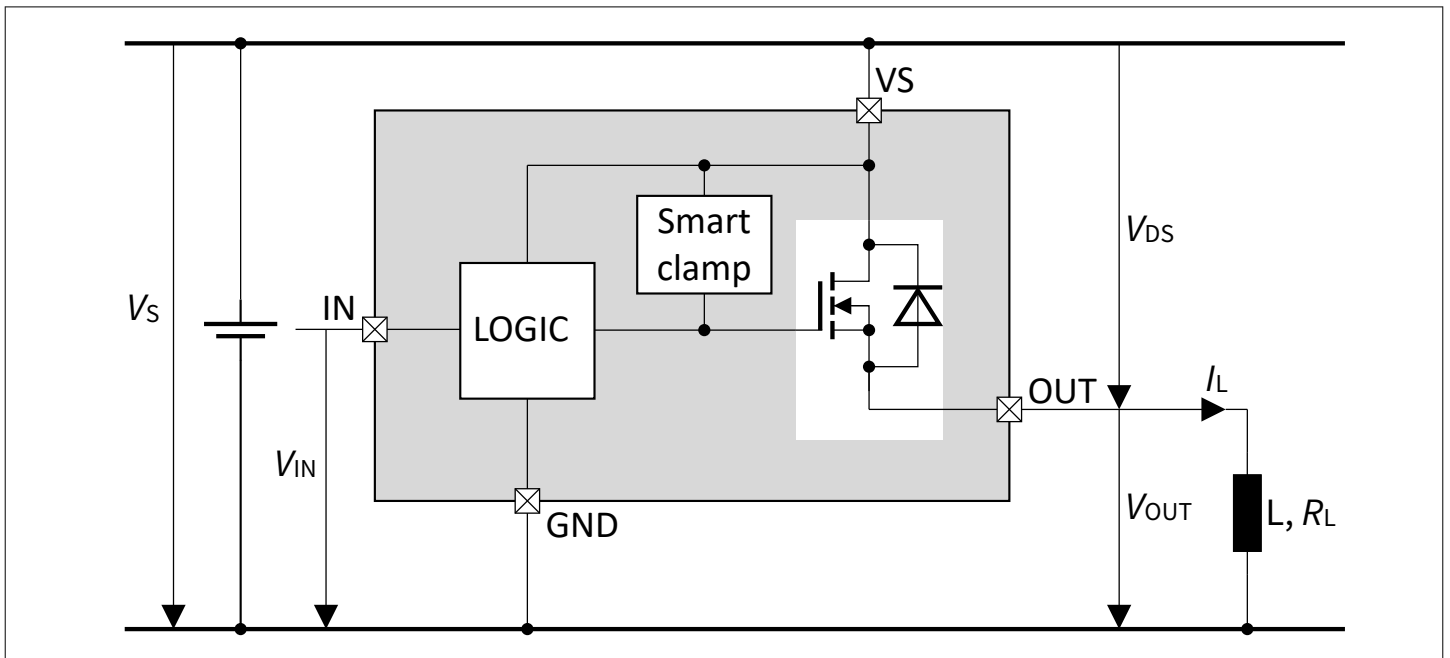

**Figure 11** Output clamp

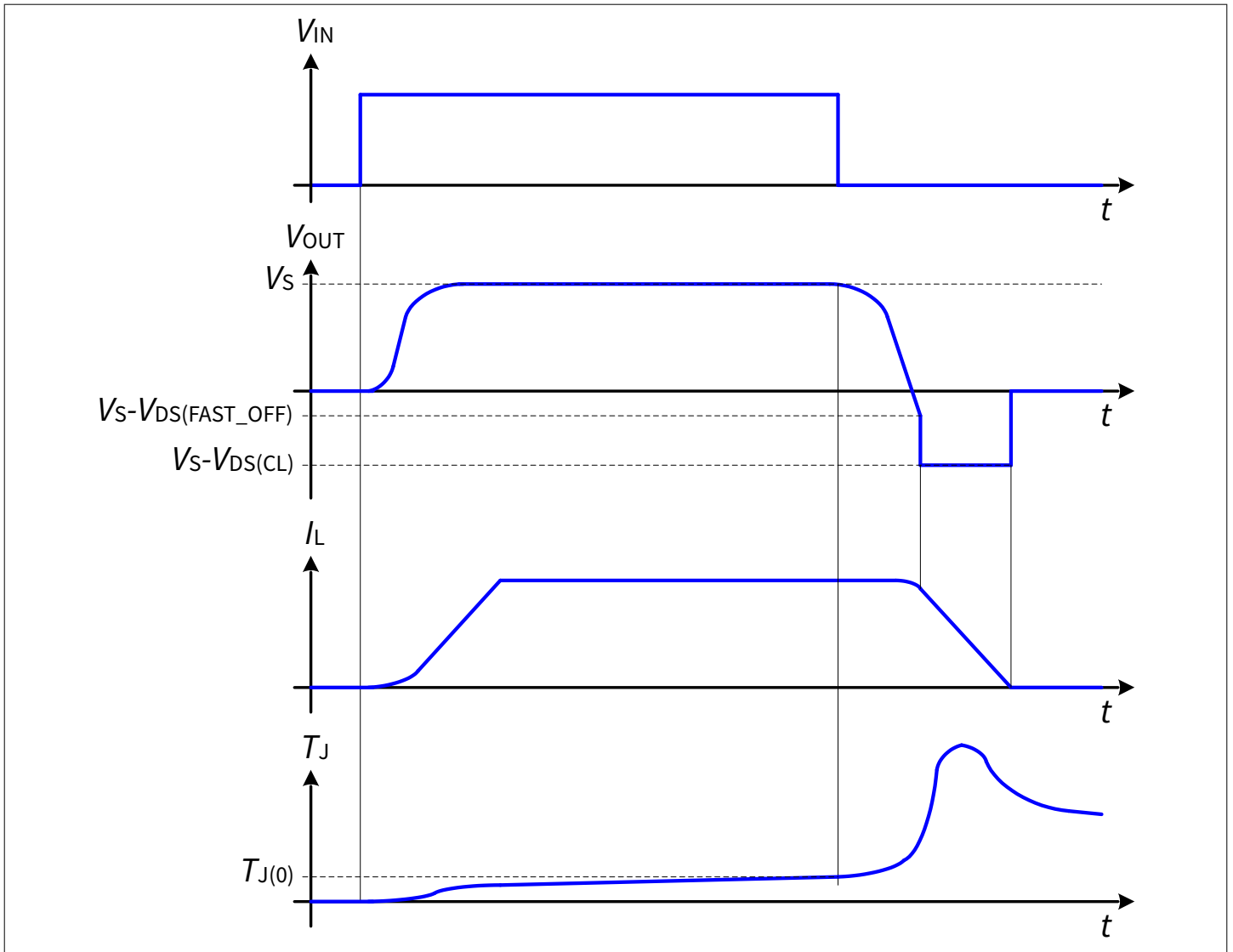

**Figure 12** Switching an inductance

The device features a fast switch off when driving an inductive load in order to increase the energy capability. The fast turn off is triggered when  $V_{DS}$  is higher than  $V_{DS(FAST\_OFF)}$ . Please refer to [Figure 12](#) for details.

The device must not be reactivated ( $V_{IN}$  goes from low to high) before  $t_{IN(RESETDELAY)}$ . Otherwise the device may not turn on and can be latched.

### 5.1.4.2 Maximum load inductance

During the demagnetization of inductive loads, the energy stored in the inductance must be dissipated in the device. This energy can be calculated with the following equation (2), where  $R_L$  is the parasitic resistance of the inductance:

$$E = V_{DS(CL)} \times \frac{L}{R_L} \times \left[ \frac{(V_S - V_{DS(CL)})}{R_L} \times \ln \left( 1 - \frac{R_L \times I_L}{(V_S - V_{DS(CL)})} \right) + I_L \right] \quad (2)$$

(2) can be simplified under the assumption that  $R_L = 0 \Omega$ . It then becomes:

$$E = \frac{1}{2} \times L \times I_L^2 \times \left( 1 - \frac{V_S}{(V_S - V_{DS(CL)})} \right) \quad (3)$$

The energy, which is converted into heat, is limited by the thermal design of the component. See [Figure 6](#) for the maximum allowed energy dissipation as a function of the load current.

### 5.1.5 Advanced switch-off behavior

In order to reduce the device stress when switching off inductive and critical loads, the device provides a functionality which results in a faster switch off behavior.

The fast switch off functionality is triggered by each of the following conditions:

- The device is turned off by applying  $V_{IN} < V_{I(L)MIN}$ . During the switch off operation,  $V_{OUT}$  drops below  $V_S - V_{DS(FAST\_OFF)}$ . See [Figure 12](#).
- The device is turned on or is already in on state ( $V_{IN} > V_{I(H)MAX}$ ). The device then detects a short circuit condition ( $I_L \geq I_{CL(0)}$ ) and initiates a protective switch off. Please refer to [Chapter 5.3.1.1](#) and [Chapter 5.3.1.2](#) for details.
- The device is turned on or is already in on state ( $V_{IN} > V_{I(H)MAX}$ ). The device then detects an overpower condition. Please refer to [Chapter 5.3.1.3](#) for details.

### 5.1.6 Inverse current behavior

When  $V_{OUT} > V_S$ , a current  $-I_L$  flows into the power output transistor (see [Figure 13](#)). This condition is known as inverse current.

If the channel is in off state, the current flows through the intrinsic body diode generating high power losses and therefore, an increase of the overall device temperature.

If the channel is in on state,  $R_{DS(INV)}$  can be expected and power dissipation in the output stage is comparable to normal operation in  $R_{DS(ON)}$ .

During inverse current condition, the channel remains in on or off state as long as  $|I_L| < |I_{L(NOM)}|$ .

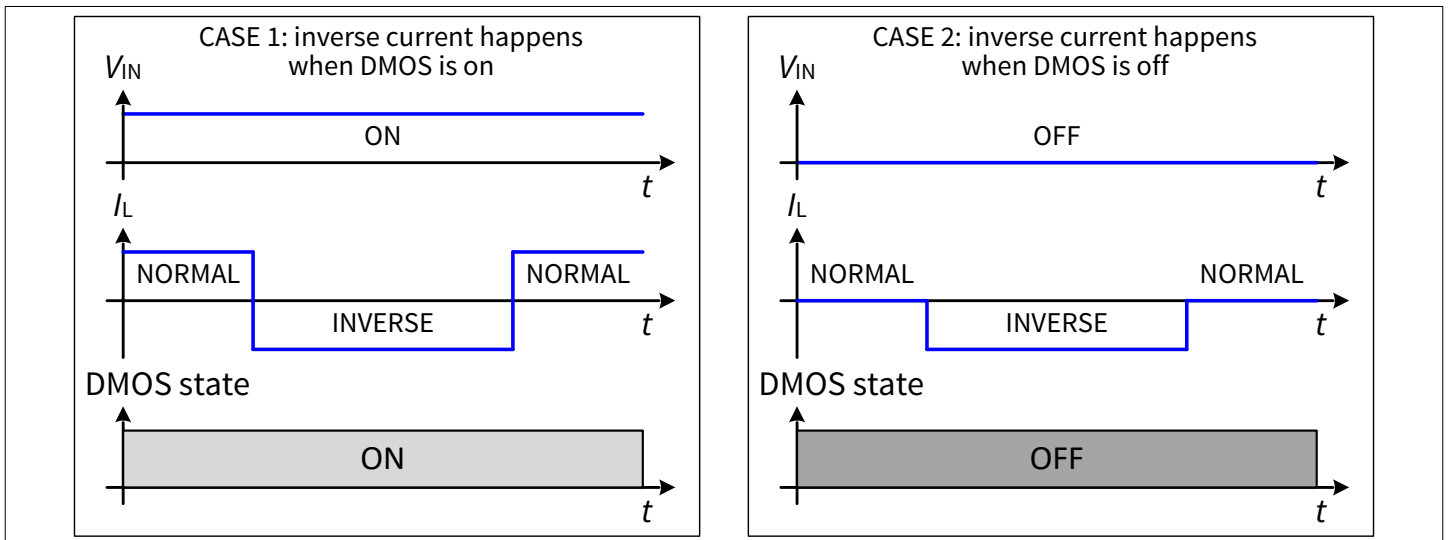

**Figure 13** Channel behavior in case of applied inverse current

## 5.2 Digital input pins: IN and DEN

This section applies to the two digital pins of the device: IN and DEN.

The input circuitry is compatible with 3.3 V and 5 V logic levels. These two pins can also be directly tied to  $V_S$ .

The input circuitry tolerates negative voltages down to  $V_S - 75$  V: see the limits for parameters  $V_{IN}$  and  $V_{DEN}$  in Table 3.

The Figure 14 below shows the electrical equivalent input circuitry.

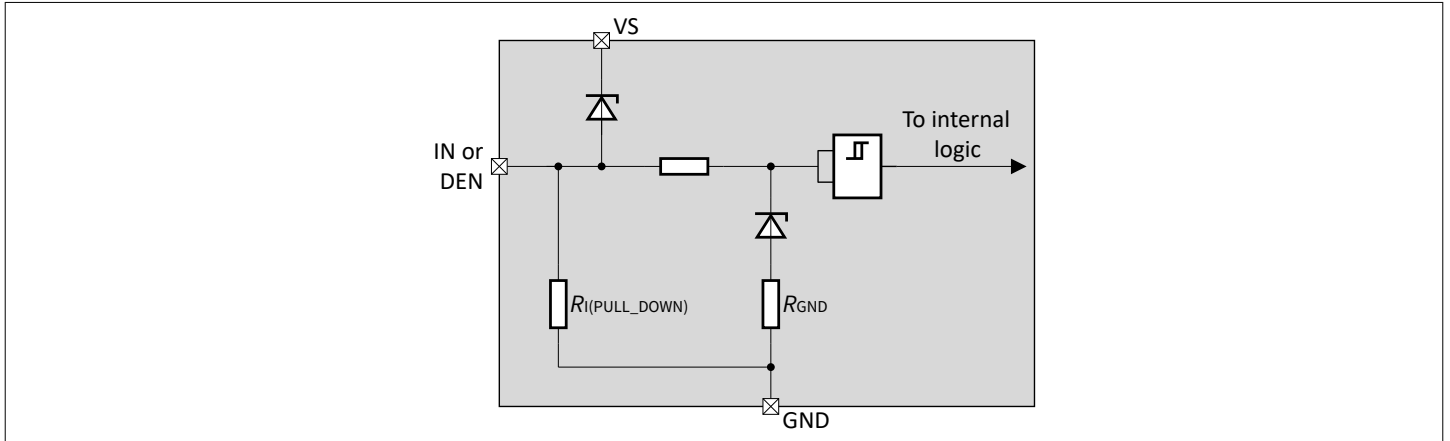
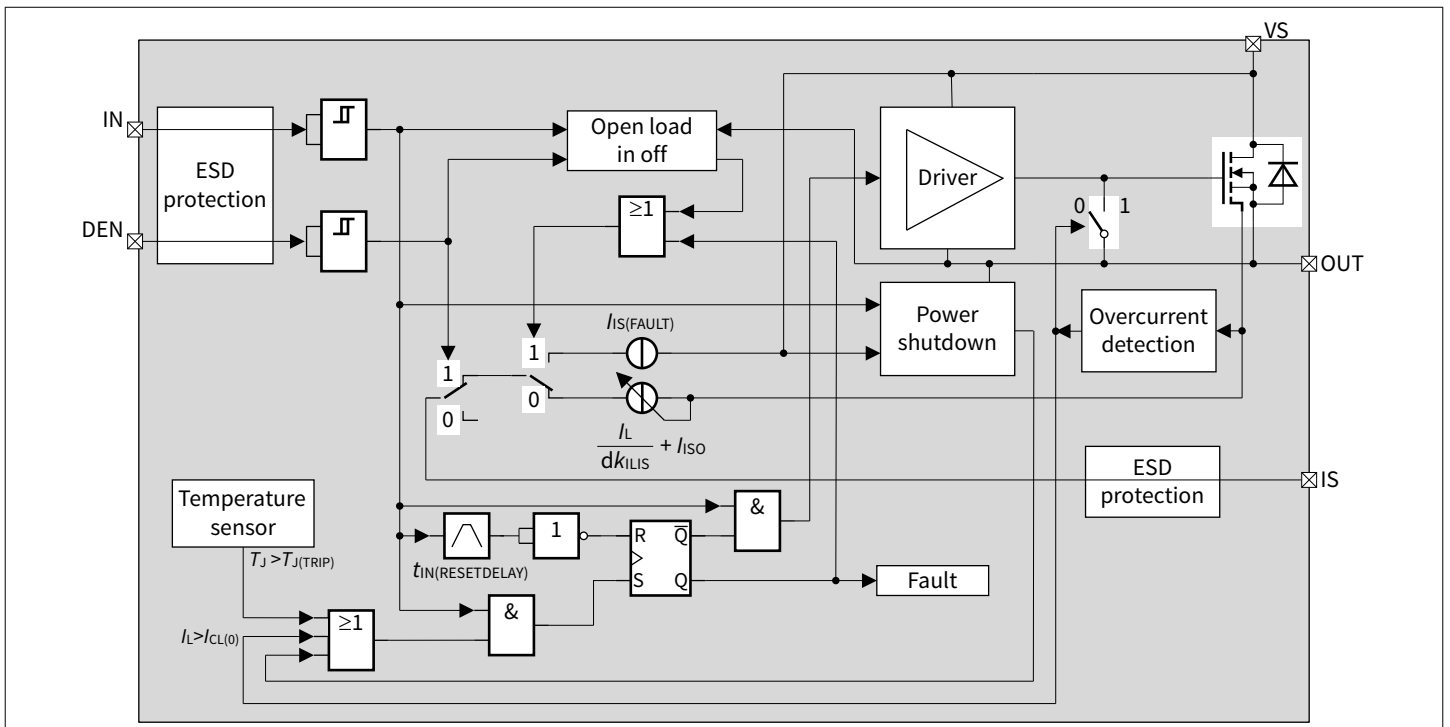

**Figure 14** Simplified schematics of the input pins circuitry

## 5.3 Protection functions

The device provides integrated protective functions. They are designed to prevent the destruction of the IC when it is exposed to fault conditions described in the present datasheet. These fault conditions are considered as outside the normal operating range. Protection functions are designed neither for continuous nor for repetitive operation.

The Figure 15 below describes the typical functionality of the diagnosis and protection blocks.



**Figure 15** Diagram of diagnosis and protection blocks

### 5.3.1 Overload protection

In case of overload, high inrush current or short circuit to ground, the device offers several protection mechanisms. An overcurrent, an overtemperature or an overpower shutdown switches off the output and latches the device. There are 2 ways to reset the internal latch:

- Set  $V_{IN} < V_{I(L)MIN}$  for  $t > t_{IN(RESETDELAY)}$
- Set  $V_S < V_{S(UVL)}$  for  $t > t_{IN(RESETDELAY)}$

For overload (short circuit or overtemperature), the maximum retry cycle ( $f_{FAULT}$ ) under fault condition must be considered.

#### 5.3.1.1 Activation of the switch into short circuit (short circuit type 1)

When the switch is activated into short circuit, the current rises rapidly. When the output current reaches  $I_{CL(0)}$  value, the device is latched and turns off after  $t_{OFF(TRIP)}$  which leads to an overshoot on the output current above  $I_{CL(0)}$ .

#### 5.3.1.2 Short circuit appearance when the device is already on (short circuit type 2)

When the device is in on state and a short circuit to ground appears at the output with an overcurrent higher than  $I_{CL(0)}$ , the device automatically turns off and latches.

#### 5.3.1.3 Overpower shutdown (PSD)

The device integrates an overpower shutdown protection in order to limit the power dissipation. The target is to limit the maximum junction temperature in case of:

- A soft short circuit, where the short circuit resistance is too high to trigger the overcurrent protection ( $I_L < I_{CL(0)}$ )
- Repetitive short circuits
- A short circuit in applications with a high resistor and/or inductor in the battery line, where  $V_S$  drops below  $V_{S(PSD)}$  and the load current does not reach the  $I_{CL(0)}$

In such conditions, the overpower shutdown protection is activated and latches the device after  $t_{PSD(UV)}$ .

**Note:** It also limits the maximum PWM frequency below the maximum value of  $f_{IN}$ . See Figure 16 below:

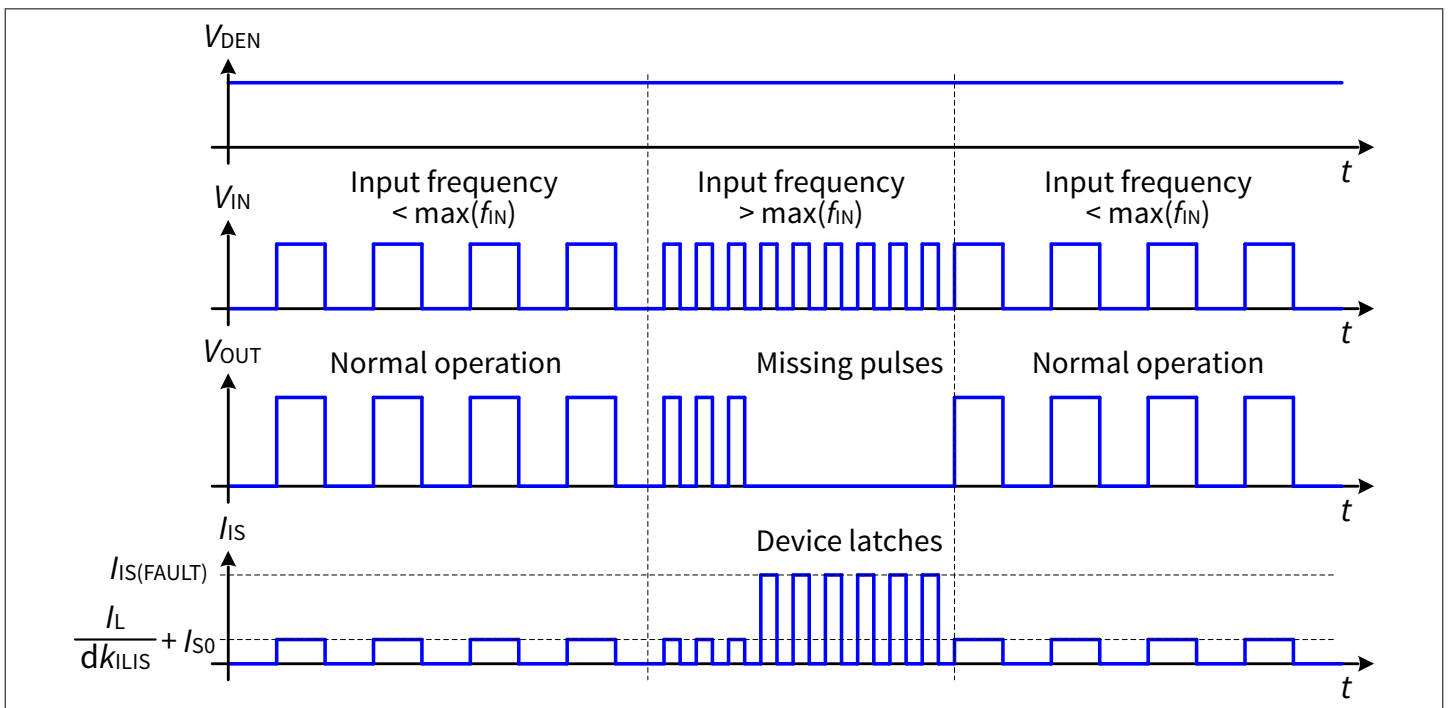

**Figure 16** Behavior during PWM operation above the maximum value of  $f_{IN}$

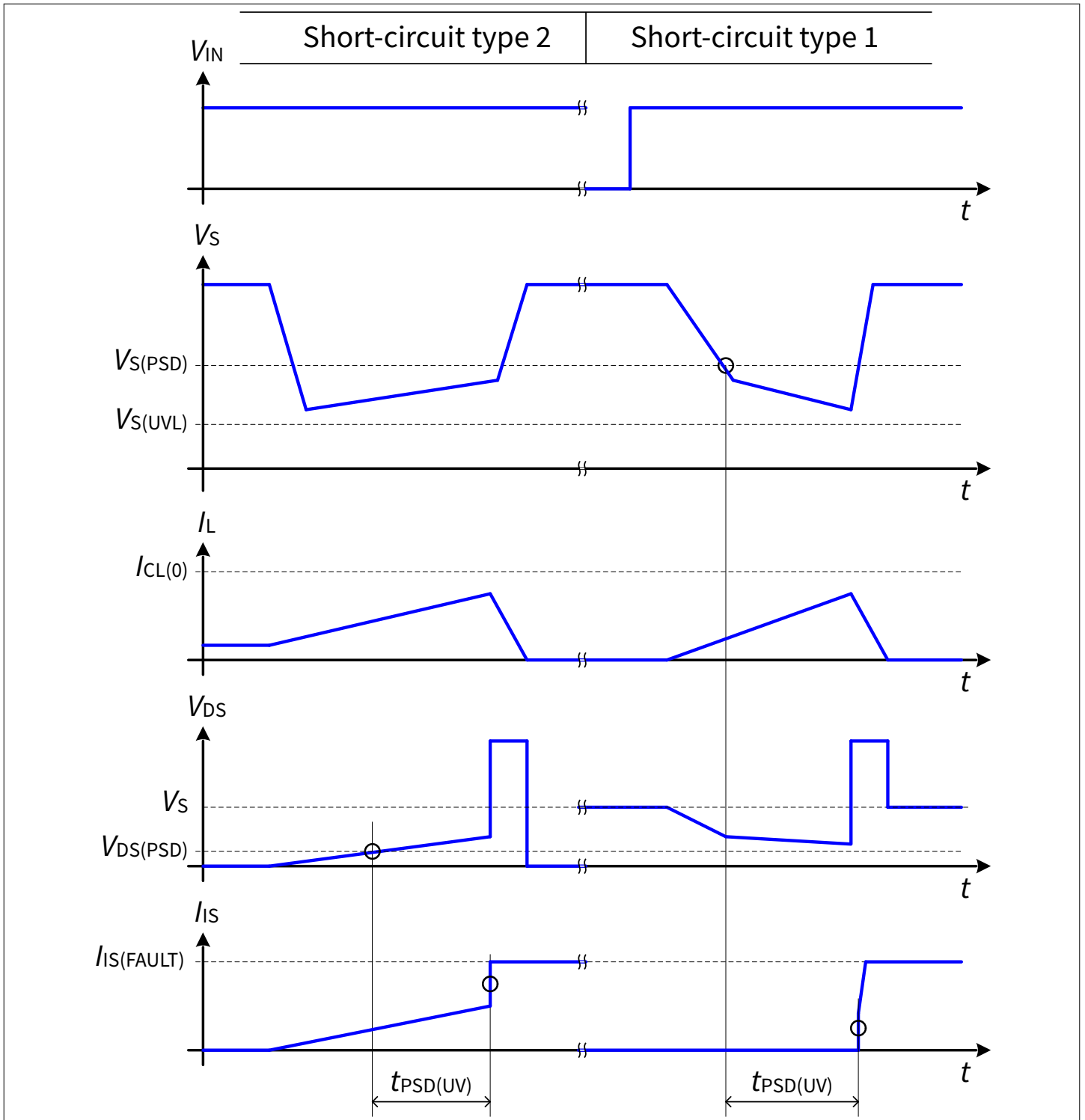

**Figure 17** Overpower shutdown behavior during supply voltage drops

### 5.3.1.4 Temperature limitation in the power MOSFET

The device incorporates a temperature sensor. Triggering the overtemperature ( $T_J > T_{J(TRIP)}$ ) switches off the power MOSFET to prevent destruction and latches the device.

### 5.3.2 Ground loss protection

In case of loss of device ground, while the load remains connected to ground, the device protects itself by automatically turning off (when it was previously on) or remains off, regardless of the voltage applied at IN pin.

## 5.4 Diagnosis functions

For diagnosis purposes, the device provides on the IS pin, either an image of the output load current, or a constant fault current.

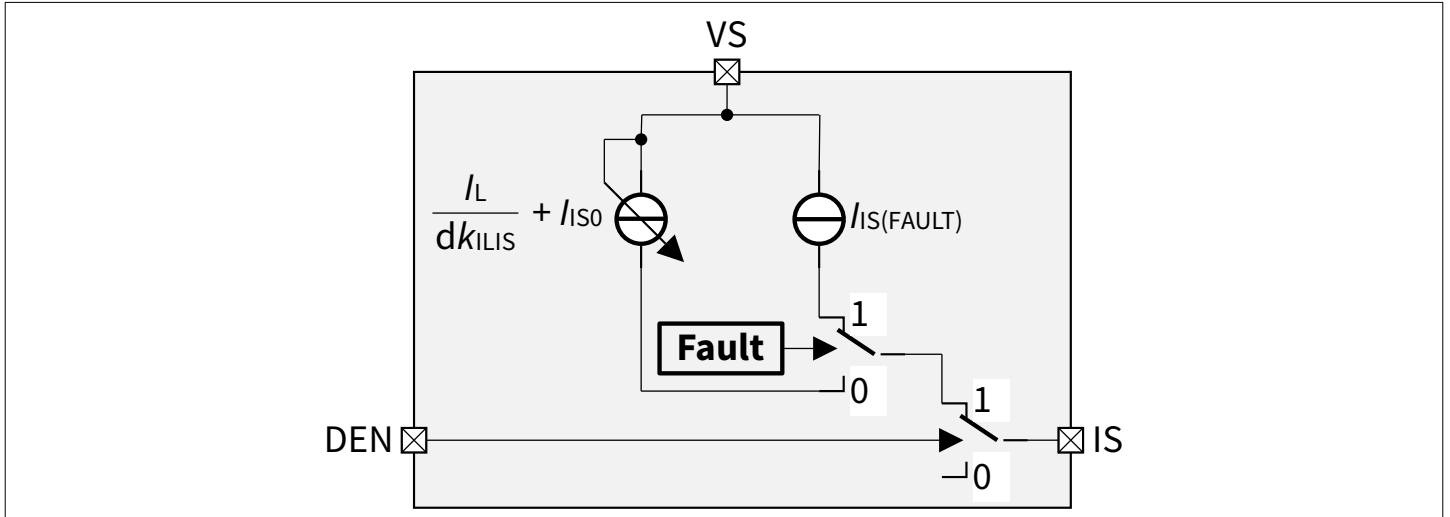

**Figure 18** Diagnosis block diagram

### 5.4.1 Overview

Operation mode	$V_{IN}$	$V_{DEN}$	$V_{OUT}$	Diagnosis output
Normal condition	Low (OFF)	High	GND	$I_{IS(OFF)}$
Short circuit to GND			GND	$I_{IS(OFF)}$
Overtemperature			GND	$I_{IS(OFF)}$
Short circuit to VS			$V_S$	$I_{IS(FAULT)}$
Open load			$V_{OUT} > V_{OUT(OL\_OFF)}$ <sup>1)</sup>	$I_{IS(FAULT)}$
			$V_{OUT} < V_{OUT(OL\_OFF)}$	$I_{IS(OFF)}$
Normal condition	High (ON)		$\sim V_S$	$I_{IS} = (I_L / dk_{ILIS}) + I_{ISO}$
Short circuit to GND			GND	$I_{IS(FAULT)}$
Overtemperature			GND	$I_{IS(FAULT)}$
Short circuit to VS			$V_S$	$I_{IS} \leq (I_L / dk_{ILIS}) + I_{ISO}$
Open load			$V_S$	$I_{ISO}$ if positive, $I_{IS(OFF)}$ if negative
All conditions	N.a.	Low	N.a.	$I_{IS(OFF)}$

1) With additional pull-up resistor

### 5.4.2 Diagnosis in on state

A current proportional to the load current is provided at pin IS when the following conditions are fulfilled:

- The power output stage is switched on with  $(V_S - V_{IS}) > \text{Min}(V_S - V_{IS})$
- The diagnosis is enabled ( $V_{DEN} > V_{I(H)}$ )
- No fault is present or was present
- The  $R_{IS}$  recommended value is 2k $\Omega$

**5 Functional description**

A current  $I_{IS(FAULT)}$  is provided at IS pin when:

- The device is latched due to a previous overcurrent, overtemperature or overpower
- The diagnosis is enabled ( $V_{DEN} > V_{I(H)}$ )

Figure 19 and Figure 21 show the current sense as a function of the load current in the power MOSFET.

Usually, a pull-down resistor  $R_{IS}$  is connected to the current sense pin IS.

The dotted curve represents the typical sense current, assuming a typical  $dk_{ILIS}$  factor value.

The area between the two solid curves shows the current sense accuracy the device is able to provide.

$$I_{IS} = \frac{I_L}{dk_{ILIS}} + I_{IS0} \quad \text{with } I_{IS} \geq 0 \quad (4)$$

Where the definition of  $dk_{ILIS}$  is:

$$dk_{ILIS} = \frac{I_{L2} - I_{L1}}{I_{IS2} - I_{IS1}} \quad (5)$$

the definition  $I_{IS0}$  is:

$$I_{IS0} = I_{IS1} - \frac{I_{L1}}{dk_{ILIS}} \quad (6)$$

and the definition of  $I_{L0}$  is:

$$I_{L0} = I_{L1} - (I_{IS1} \times dk_{ILIS}) \quad (7)$$

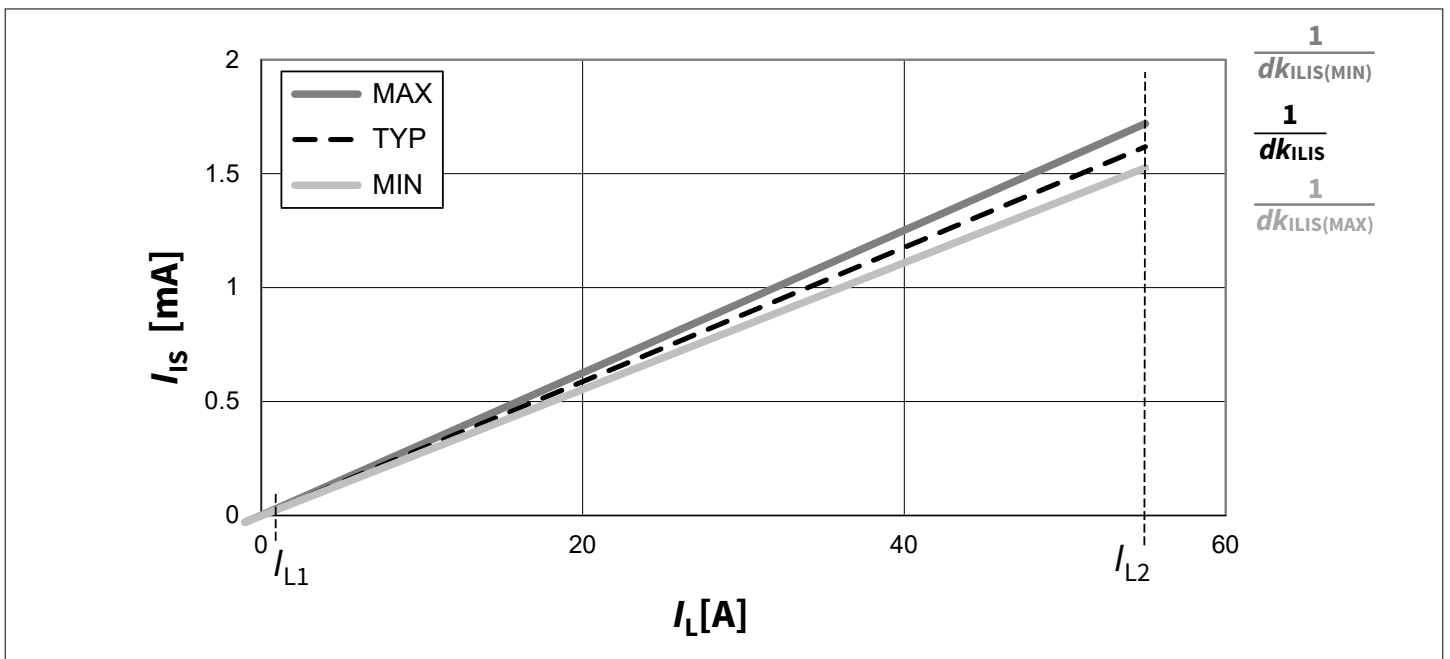

**Figure 19** Current sense at IS pin as a function of load current

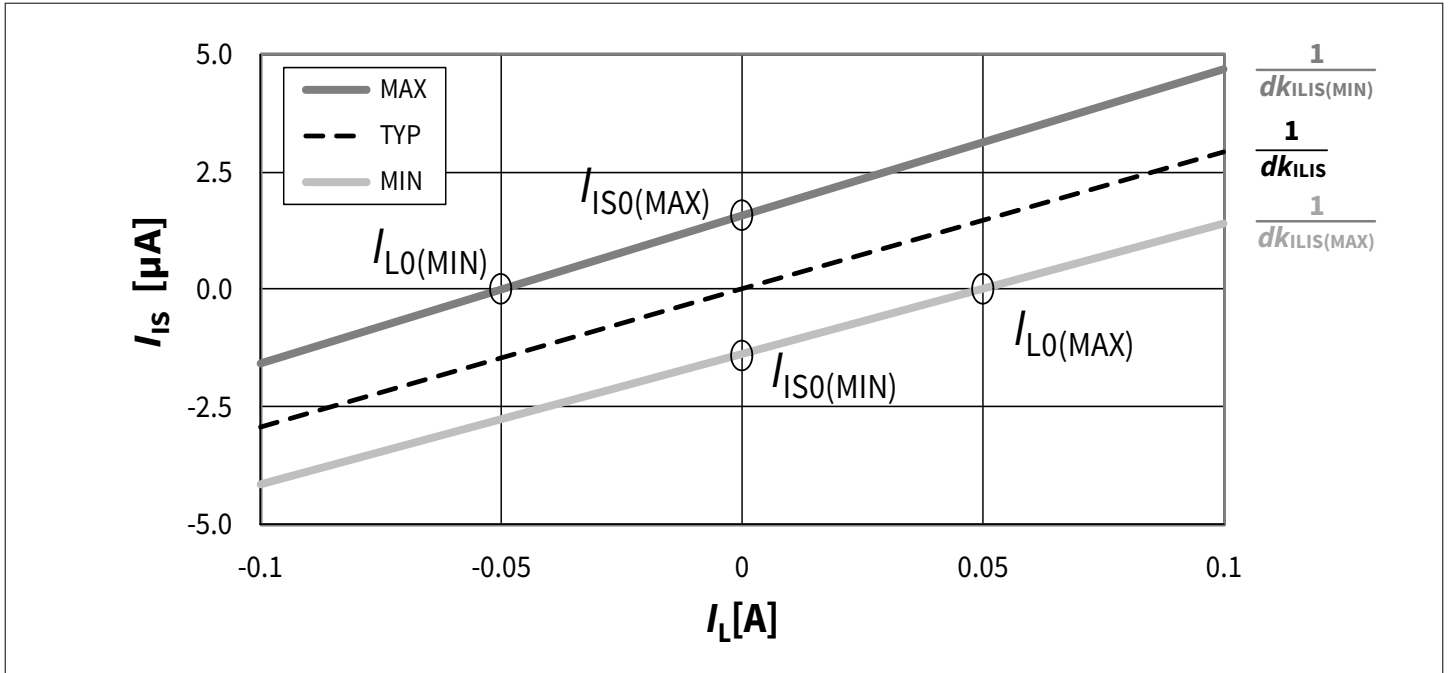

Figure 20  $I_{ISO}$  and  $I_{LO}$  definition

### 5.4.2.1 Sense signal variation and calibration

In some applications, an enhanced accuracy is required around the device nominal current range  $I_{L(NOM)}$ . To improve the accuracy, a calibration in the application can be implemented; the best results are achieved using a two-point calibration.

Once calibrated, the  $I_{IS}$  variation over temperature and aging can be described with the parameters  $\Delta(dk_{ILIS(CAL)})$  and the  $\Delta I_{ISO(CAL)}$ .

The grey solid line in Figure 21 is the current sense ratio calculated from the two-point calibration at a given temperature.

The slope of this line is calculated as:

$$\frac{1}{dk_{ILIS(CAL)}} = \frac{I_{IS(CAL)2} - I_{IS(CAL)1}}{I_{L(CAL)2} - I_{L(CAL)1}} \quad (8)$$

The offset is calculated as:

$$I_{ISO(CAL)} = I_{IS(CAL)1} - \frac{I_{L(CAL)1}}{dk_{ILIS(CAL)}} = I_{IS(CAL)2} - \frac{I_{L(CAL)2}}{dk_{ILIS(CAL)}} \quad (9)$$

These two parameters, slope and offset, are accurate when the device is operated at the same ambient temperature as the one used during the calibration.

However, both parameters are temperature and lifetime dependant by a few percent, which results in an additional inaccuracy when the ambient temperature changes or when the device has been operated for a long time.

The grey area in Figure 21 shows the range of values for these two parameters across temperature and load current.

It is visible that the accuracy of the load current sensing is improved, when compared to the darkest lines showing the spread without calibration.

**5 Functional description**

In the application, when a sense current value  $I_{IS}$  is measured, the corresponding load current can be calculated as follows:

$$I_L = dk_{ILIS(CAL)} \times (1 + \Delta(dk_{ILIS(CAL)})) \times (I_{IS} - I_{ISO(CAL)} - \Delta I_{ISO(CAL)}) \quad (10)$$

where:

- $dk_{ILIS(CAL)}$  is the current sense ratio calculated after two-points calibration, as defined in (8)
- $\Delta(dk_{ILIS(CAL)})$  is the additional variation of the current sense ratio over life time and temperature (in absolute value, not in percentage)
- $I_{ISO(CAL)}$  is the current sense offset calculated after two points calibration, as defined in (9), and
- $\Delta I_{ISO(CAL)}$  is the additional variation of the offset over life time and temperature (in absolute value, not in percentage)

For a calibration at 25°C,  $\Delta I_{ISO(CAL)}$  varies over temperature and life time according to the following equations. For positive  $I_{ISO(CAL)}$  values ( $I_{ISO(CAL)} > 0$ ):

$$MaxI_{ISO}(@T_J = 150^\circ C) - MaxI_{ISO}(@T_J = 25^\circ C) \leq \Delta I_{ISO(CAL)} \leq MaxI_{ISO}(@T_J = -40^\circ C) - MaxI_{ISO}(@T_J = 25^\circ C) \quad (11)$$

For negative  $I_{ISO(CAL)}$  values ( $I_{ISO(CAL)} < 0$ ):

$$MinI_{ISO}(@T_J = 150^\circ C) - MinI_{ISO}(@T_J = 25^\circ C) \geq \Delta I_{ISO(CAL)} \geq MinI_{ISO}(@T_J = -40^\circ C) - MinI_{ISO}(@T_J = 25^\circ C) \quad (12)$$

(10) actually provides four solutions for load current, considering that  $\Delta(dk_{ILIS(CAL)})$  and  $\Delta I_{ISO(CAL)}$  can both be positive or negative. The load current  $I_L$  corresponding to a known sense current  $I_{IS}$  spreads between:

- A minimum  $I_L$  value resulting from the combination of lowest  $\Delta(dk_{ILIS(CAL)})$  value and highest  $\Delta I_{ISO(CAL)}$  and
- A maximum  $I_L$  value resulting from the combination of highest  $\Delta(dk_{ILIS(CAL)})$  value and lowest  $\Delta I_{ISO(CAL)}$

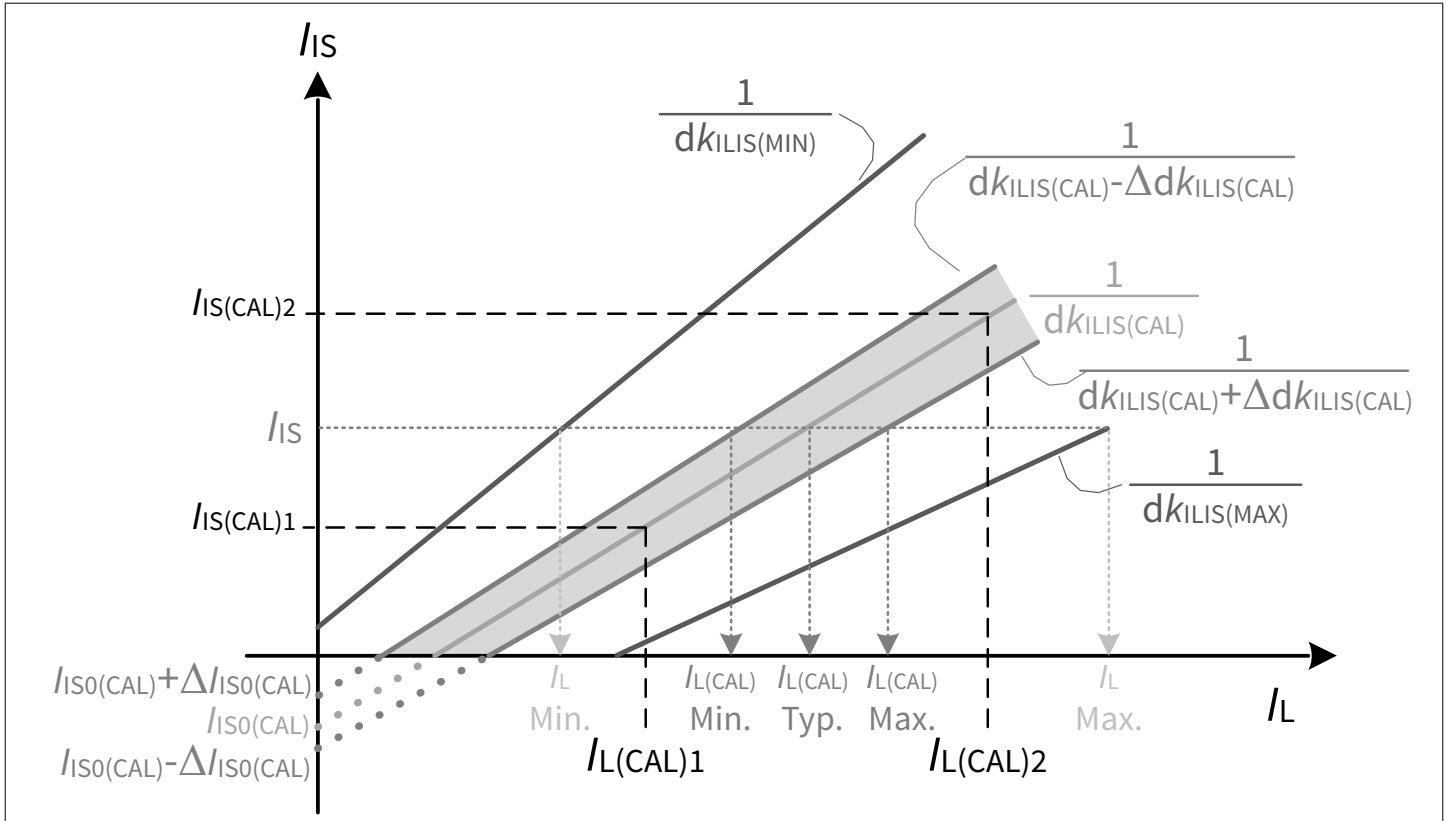

**Figure 21** Improved current sense accuracy after 2 points calibration

### 5.4.2.2 Sense signal timing

The [Figure 22](#) below shows the timings at turn on and when enabling/disabling the current sense feature through the DEN pin:

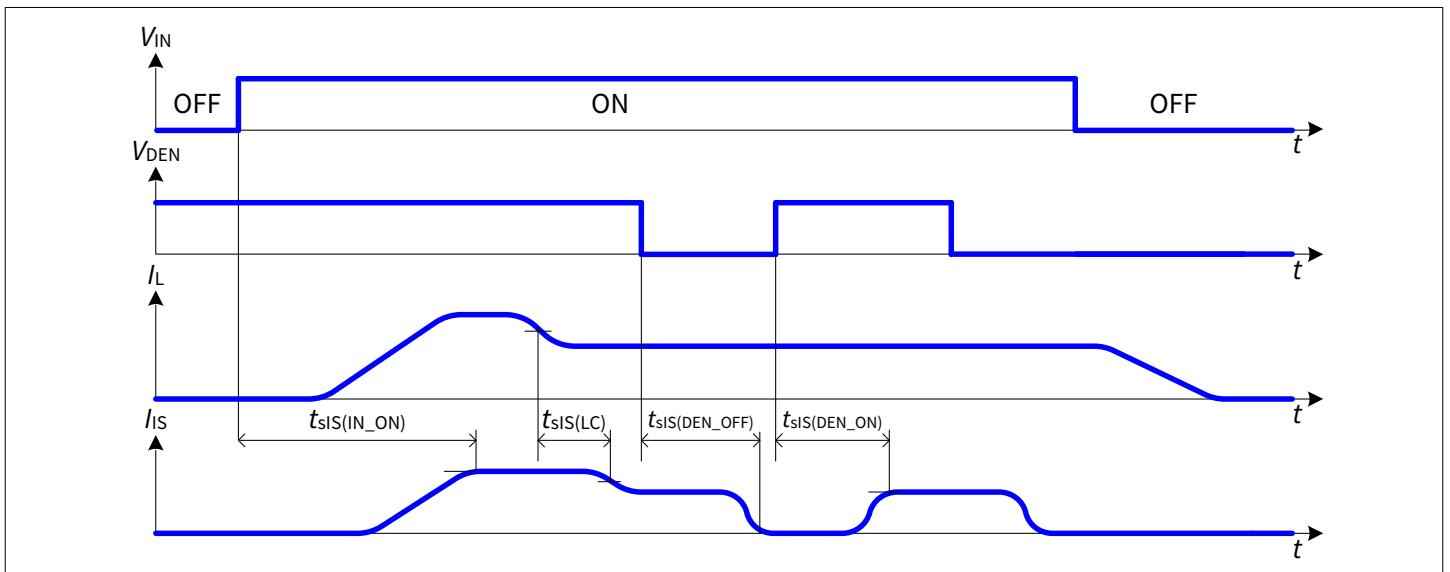

**Figure 22** Current sense timing in normal operation

The [Figure 23](#) below describes the IS pin behavior under protection conditions:

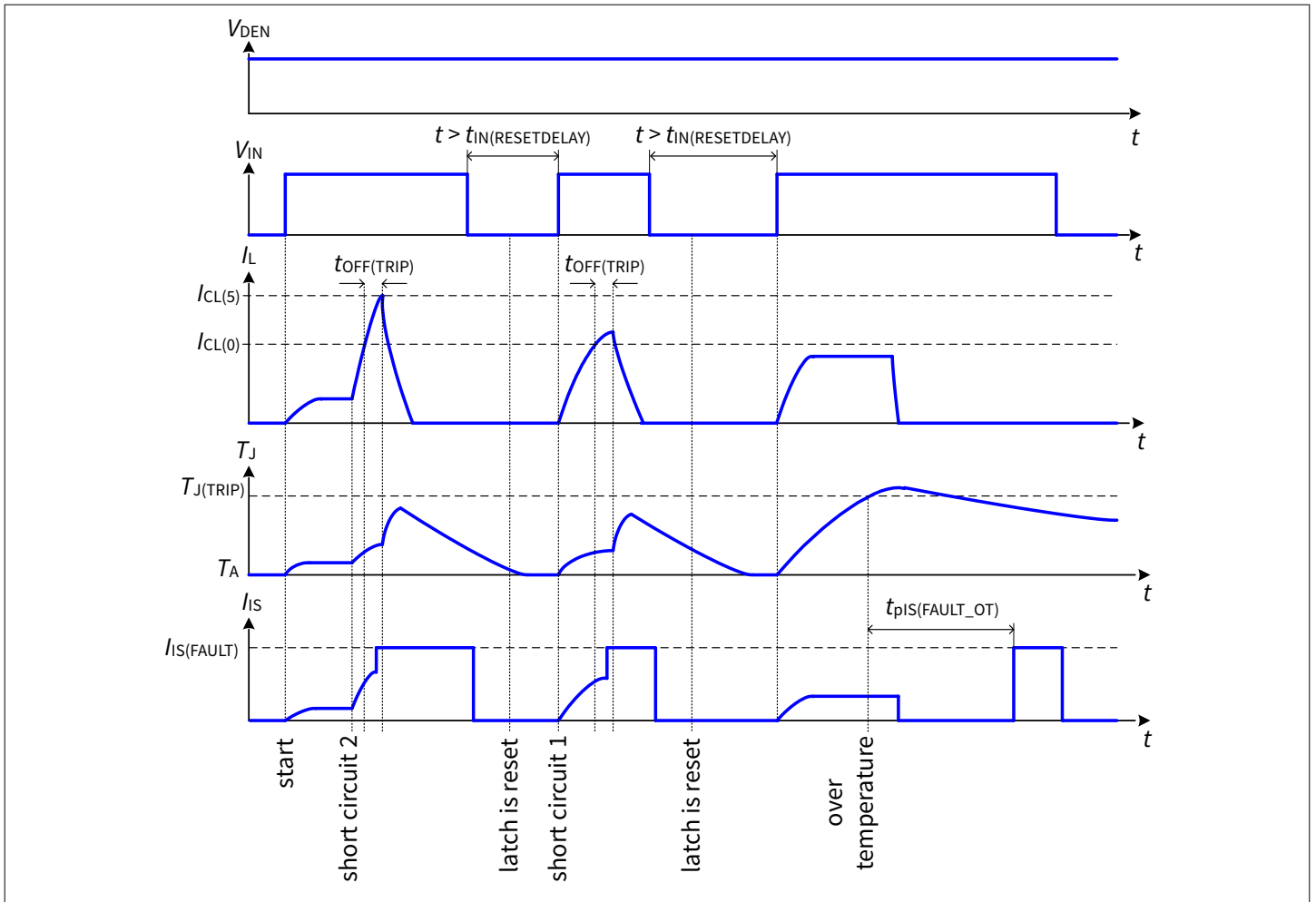
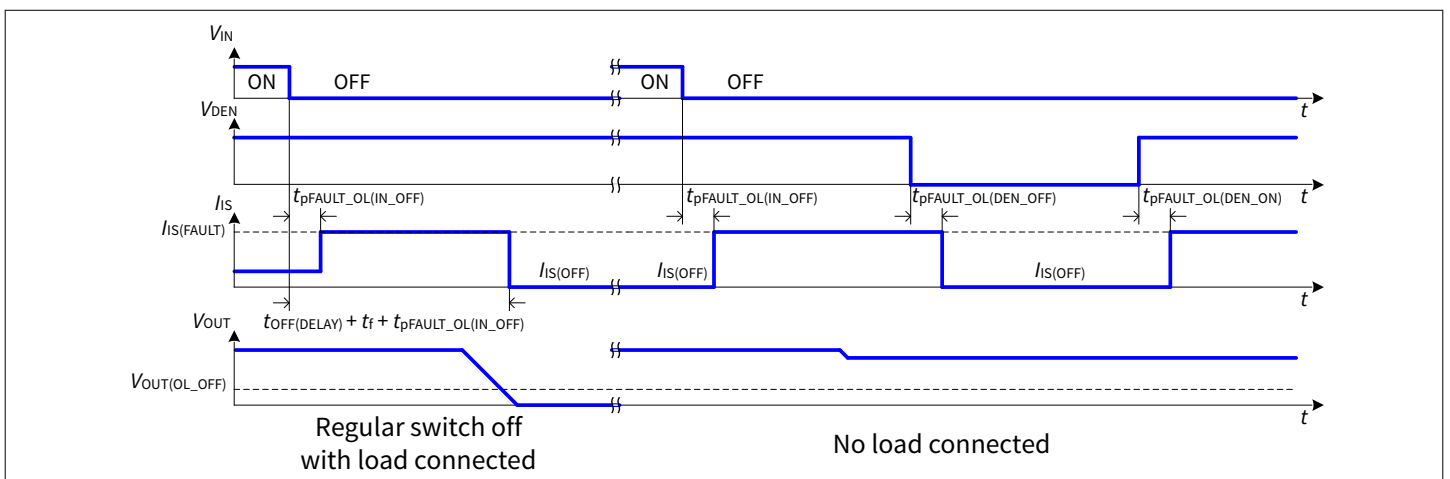

**Figure 23** IS pin behavior under protection

### 5.4.3 Diagnosis in off state

The device features a detection of open load when it is in off state. An internal comparator is monitoring  $V_{OUT}$ . If  $V_{OUT} > V_{OUT(OL\_OFF)}$  and  $V_{DEN} > V_{I(H)MAX}$ , the current at IS pin is  $I_{IS(FAULT)}$ .

In order to pull-up OUT in case of open load condition, an external pull-up resistor must be connected between VS and OUT pins. This external resistor must be switchable to keep the quiescent current as low as possible on VS pin.



**Figure 24** Behavior of the open load detection in off feature with and without load connected

## 5.5 Electrical characteristics

**Table 6 Electrical characteristics table**

$V_S = 12\text{ V to } 54\text{ V}$ ,  $T_J = -40^\circ\text{C to } +150^\circ\text{C}$  unless otherwise specified. For a given temperature or voltage range, typical values are specified at  $V_S = 48\text{ V}$ ,  $T_J = 25^\circ\text{C}$ .

Parameter	Symbol	Values			Unit	Note or condition	P-Number
		Min.	Typ.	Max.			

### Operating and standby currents

Standby current on VS pin with load	$I_{VS(OFF\_L)}$	–	5	7	$\mu\text{A}$	$V_{IN} = V_{DEN} = V_{OUT} = 0\text{ V}$ , $R_{IS} = 2\text{ k}\Omega$ , $T_J \leq 85^\circ\text{C}$ , 7 ms after $V_{IN} \leq V_{I(L)MIN}$	PRQ-65
Standby current on VS pin with load	$I_{VS(OFF\_L)}$	–	10	100	$\mu\text{A}$	$V_{IN} = V_{DEN} = V_{OUT} = 0\text{ V}$ , $R_{IS} = 2\text{ k}\Omega$ , $T_J \leq 150^\circ\text{C}$ , 7 ms after $V_{IN} \leq V_{I(L)MIN}$	PRQ-67
Standby current on VS pin with load and DEN active	$I_{VS(OFF\_DEN)}$	–	200	400	$\mu\text{A}$	$V_{IN} = V_{OUT} = 0\text{ V}$ , $V_{DEN} = 5\text{ V}$ , $R_{IS} = 2\text{ k}\Omega$ , $T_J \leq 85^\circ\text{C}$ , 7 ms after $V_{IN} \leq V_{I(L)MIN}$	PRQ-66
Supply current on GND pin in on state with digital level on IN pin	$I_{GND(ON\_dig-lev)}$	–	2.5	4.2	$\text{mA}$	$V_{I(H)MAX} \leq V_{IN} \leq 5.5\text{ V}$ $V_{I(H)MAX} \leq V_{DEN} \leq 5.5\text{ V}$	PRQ-68
Supply current on GND pin in on state with high voltage on IN pin	$I_{GND(ON\_High-V)}$	–	3	5.5	$\text{mA}$	$5.5\text{ V} < V_{IN} \leq V_S$ $5.5\text{ V} < V_{DEN} \leq V_S$	PRQ-324
Ground resistor	$R_{GND}$	130	180	230	$\Omega$	–	PRQ-69

### Power stage

On-state resistance in forward condition	$R_{DS(ON)}$	–	3.0	–	$\text{m}\Omega$	<sup>1)</sup> $T_J = 25^\circ\text{C}$	PRQ-303
On-state resistance in forward condition	$R_{DS(ON)}$	–	5.8	7.0	$\text{m}\Omega$	$T_J = 150^\circ\text{C}$	PRQ-304
On-state resistance in inverse condition	$R_{DS(INV)}$	–	3.0	7.0	$\text{m}\Omega$	–	PRQ-352
Nominal load current	$I_{L(NOM)}$	22.5	25	–	$\text{A}$	<sup>1)</sup> $T_A = 85^\circ\text{C}$ , $T_J \leq 150^\circ\text{C}$ $R_{thJA(2s2p)}$	PRQ-310
Drain to source smart clamp voltage	$V_{DS(CL)}$	70	76	–	$\text{V}$	$V_{DS(CL)} = V_S - V_{OUT}$ $I_L = 10\text{ mA}$	PRQ-89
Drain to source smart clamp voltage after a short-circuit detection	$V_{DS(CL\_SC)}$	–	70	–	$\text{V}$	$V_{DS(CL\_SC)} = V_S - V_{OUT}$ after activation of the short-circuit protection ( $I_L > I_{CL(0)}$ )	PRQ-329
Body diode forward voltage	$V_F$	–	0.6	0.8	$\text{V}$	$I_L = -25\text{ A}$ , $T_J = 150^\circ\text{C}$	PRQ-91

**(table continues...)**

**Table 6 (continued) Electrical characteristics table**

$V_S = 12\text{ V to }54\text{ V}$ ,  $T_J = -40^\circ\text{C to }+150^\circ\text{C}$  unless otherwise specified. For a given temperature or voltage range, typical values are specified at  $V_S = 48\text{ V}$ ,  $T_J = 25^\circ\text{C}$ .

Parameter	Symbol	Values			Unit	Note or condition	P-Number
		Min.	Typ.	Max.			
Output leakage current	$I_{\text{OUT(OFF)}}$	–	10	20	$\mu\text{A}$	$V_{\text{IN}} = V_{\text{DEN}} = V_{\text{OUT}} = 0\text{ V}$ , $V_S = 60\text{ V}$ , $T_J \leq 85^\circ\text{C}$ , 7 ms after $V_{\text{IN}} < V_{\text{I(L)MIN}}$	PRQ-92
Output leakage current	$I_{\text{OUT(OFF)}}$	–	10	50	$\mu\text{A}$	$V_{\text{IN}} = V_{\text{DEN}} = V_{\text{OUT}} = 0\text{ V}$ , $V_S = 60\text{ V}$ , $T_J \leq 150^\circ\text{C}$ , 7 ms after $V_{\text{IN}} < V_{\text{I(L)MIN}}$	PRQ-93
Turn on slew rate	$dV_{\text{ON/dt}}$	0.75	1.5	3	$\text{V}/\mu\text{s}$	$V_{\text{OUT}}$ from 25% to 50% of $V_S$ $R_L = R_{\text{L(NOM)}}$ , $V_S = 48\text{ V}$	PRQ-94
Turn on slew rate	$dV_{\text{ON/dt}}$	0.22	0.5	1	$\text{V}/\mu\text{s}$	<sup>1)</sup> $V_{\text{OUT}}$ from 25% to 50% of $V_S$ $R_L = R_{\text{L(NOM)}} / 2$ , $V_S = 24\text{ V}$	PRQ-389
Turn off slew rate	$-dV_{\text{OFF/dt}}$	0.75	1.5	3	$\text{V}/\mu\text{s}$	$V_{\text{OUT}}$ from 50% to 25% of $V_S$ $R_L = R_{\text{L(NOM)}}$ , $V_S = 48\text{ V}$	PRQ-97
Turn off slew rate	$-dV_{\text{OFF/dt}}$	0.22	0.5	1	$\text{V}/\mu\text{s}$	<sup>1)</sup> $V_{\text{OUT}}$ from 50% to 25% of $V_S$ $R_L = R_{\text{L(NOM)}} / 2$ , $V_S = 24\text{ V}$	PRQ-390
Rising time during turn on	$t_r$	15	35	70	$\mu\text{s}$	$V_{\text{OUT}}$ from 20% to 80% of $V_S$ $R_L = R_{\text{L(NOM)}}$ , $V_S = 48\text{ V}$	PRQ-100
Rising time during turn on	$t_r$	17	45	90	$\mu\text{s}$	<sup>1)</sup> $V_{\text{OUT}}$ from 20% to 80% of $V_S$ $R_L = R_{\text{L(NOM)}} / 2$ , $V_S = 24\text{ V}$	PRQ-391
Falling time during turn off	$t_f$	15	35	70	$\mu\text{s}$	$V_{\text{OUT}}$ from 80% to 20% of $V_S$ $R_L = R_{\text{L(NOM)}}$ , $V_S = 48\text{ V}$	PRQ-103
Falling time during turn off	$t_f$	17	45	90	$\mu\text{s}$	<sup>1)</sup> $V_{\text{OUT}}$ from 80% to 20% of $V_S$ $R_L = R_{\text{L(NOM)}} / 2$ , $V_S = 24\text{ V}$	PRQ-392
Turn on time	$t_{\text{ON(DELAY)}}$	22	55	125	$\mu\text{s}$	From ( $V_{\text{IN}} > V_{\text{I(H)}}$ ) to $V_{\text{OUT}} = (20\% \times V_S)$ $R_L = R_{\text{L(NOM)}}$ , $V_S = 48\text{ V}$	PRQ-106
Turn on time	$t_{\text{ON(DELAY)}}$	22	65	150	$\mu\text{s}$	<sup>1)</sup> From ( $V_{\text{IN}} > V_{\text{I(H)}}$ ) to $V_{\text{OUT}} = (20\% \times V_S)$ $R_L = R_{\text{L(NOM)}} / 2$ , $V_S = 24\text{ V}$	PRQ-393
Turn off time	$t_{\text{OFF(DELAY)}}$	50	130	225	$\mu\text{s}$	From ( $V_{\text{IN}} < V_{\text{I(L)}}$ ) to $V_{\text{OUT}} = (80\% \times V_S)$ $R_L = R_{\text{L(NOM)}}$ , $V_S = 48\text{ V}$	PRQ-109

(table continues...)

**Table 6 (continued) Electrical characteristics table**

$V_S = 12\text{ V to }54\text{ V}$ ,  $T_J = -40^\circ\text{C to }+150^\circ\text{C}$  unless otherwise specified. For a given temperature or voltage range, typical values are specified at  $V_S = 48\text{ V}$ ,  $T_J = 25^\circ\text{C}$ .

Parameter	Symbol	Values			Unit	Note or condition	P-Number
		Min.	Typ.	Max.			
Turn off time	$t_{\text{OFF(DELAY)}}$	40	110	200	$\mu\text{s}$	<sup>1)</sup> From ( $V_{\text{IN}} < V_{\text{I(L)}}$ ) to $V_{\text{OUT}} = (80\% \times V_S)$ $R_L = R_{\text{L(NOM)}} / 2$ , $V_S = 24\text{ V}$	PRQ-394
Switch on energy	$E_{\text{ON}}$	–	12.5	–	mJ	<sup>1)</sup> $R_L = R_{\text{L(NOM)}}$ , $V_S = 48\text{ V}$	PRQ-305
Switch on energy	$E_{\text{ON}}$	–	9	–	mJ	<sup>1)</sup> $R_L = R_{\text{L(NOM)}} / 2$ , $V_S = 24\text{ V}$	PRQ-396
Switch off energy	$E_{\text{OFF}}$	–	10	–	mJ	<sup>1)</sup> $R_L = R_{\text{L(NOM)}}$ , $V_S = 48\text{ V}$	PRQ-306
Switch off energy	$E_{\text{OFF}}$	–	7	–	mJ	<sup>1)</sup> $R_L = R_{\text{L(NOM)}} / 2$ , $V_S = 24\text{ V}$	PRQ-398

**VS pin**

Power supply undervoltage shutdown	$V_{\text{S(UVL)}}$	3.0	3.7	4.4	V	$V_S$ decreasing	PRQ-118
Power supply undervoltage turn on	$V_{\text{S(UVH)}}$	4.2	5.0	6.0	V	$V_S$ increasing	PRQ-119

**Digital input pins: IN and DEN**

High level input threshold	$V_{\text{I(H)}}$	–	–	2.5	V	–	PRQ-120
Low level input threshold	$V_{\text{I(L)}}$	0.5	–	–	V	–	PRQ-121
Input voltage hysteresis	$V_{\text{I(HYS)}}$	–	0.2	–	V	–	PRQ-122
Input pull-down resistor	$R_{\text{I(PULL\_DOWN)}}$	100	200	–	k $\Omega$	–	PRQ-123

**Protection: overload**

Current trip detection level	$I_{\text{CL(0)}}$	55	85	110	A	$T_J = -40^\circ\text{C}$	PRQ-403
Current trip detection level	$I_{\text{CL(0)}}$	55	80	100	A	<sup>1)</sup> $T_J = 25^\circ\text{C}$	PRQ-307
Current trip detection level	$I_{\text{CL(0)}}$	55	75	90	A	$T_J = 150^\circ\text{C}$	PRQ-404
Current trip maximum level at 5 A/ $\mu\text{s}$	$I_{\text{CL(5)}}$	55	100	125	A	$dI_L/dt = 5\text{ A}/\mu\text{s}$ $T_J = -40^\circ\text{C}$	PRQ-407
Current trip maximum level at 5 A/ $\mu\text{s}$	$I_{\text{CL(5)}}$	55	95	115	A	<sup>1)</sup> $dI_L/dt = 5\text{ A}/\mu\text{s}$ $T_J = 25^\circ\text{C}$	PRQ-308
Current trip maximum level at 5 A/ $\mu\text{s}$	$I_{\text{CL(5)}}$	55	90	105	A	$dI_L/dt = 5\text{ A}/\mu\text{s}$ $T_J = 150^\circ\text{C}$	PRQ-408
Overload shutdown delay time	$t_{\text{OFF(TRIP)}}$	–	3.5	6	$\mu\text{s}$	–	PRQ-309

**(table continues...)**

**Table 6 (continued) Electrical characteristics table**

$V_S = 12\text{ V to }54\text{ V}$ ,  $T_J = -40^\circ\text{C to }+150^\circ\text{C}$  unless otherwise specified. For a given temperature or voltage range, typical values are specified at  $V_S = 48\text{ V}$ ,  $T_J = 25^\circ\text{C}$ .

Parameter	Symbol	Values			Unit	Note or condition	P-Number
		Min.	Typ.	Max.			
Thermal shutdown temperature	$T_{J(\text{TRIP})}$	150	175	200	$^\circ\text{C}$	<sup>1)</sup> $V_S$ in $V_{S(\text{EXT})}$ range	PRQ-141
Over power shutdown detection level	$V_{DS(\text{PSD})}$	1.25	1.5	1.75	V	<sup>1)</sup>	PRQ-142
Over power shutdown activation level	$V_{S(\text{PSD})}$	3.25	4.25	5.25	V	<sup>1)</sup>	PRQ-143
Over power shutdown time	$t_{\text{PSD}(\text{UV})}$	10	100	350	$\mu\text{s}$	Start: when [ $V_S < V_{S(\text{PSD})}$ and $V_{DS} > V_{DS(\text{PSD})}$ ] Stop: when $I_{IS} > 80\%$ $I_{IS(\text{FAULT})}$	PRQ-144

**Diagnosis function: current sense characteristics**

Current sense differential ratio	$dk_{ILIS}$	31500	34000	36500	-	$I_{L0\text{ max}} \leq I_L \leq I_{CL(0)\text{ min}}$ $V_S - V_{IS} \geq \text{Min}(V_S - V_{IS})$	PRQ-145
Calculated offset on IL when IS= 0 A at Tj = -40°C	$I_{L0}$	-50	0	50	mA	$V_S - V_{IS} \geq \text{Min}(V_S - V_{IS})$ $T_J = -40^\circ\text{C}$	PRQ-316
Calculated offset on IL when IS= 0 A at Tj = 25°C	$I_{L0}$	-40	0	40	mA	<sup>1)</sup> $V_S - V_{IS} \geq \text{Min}(V_S - V_{IS})$ $T_J = 25^\circ\text{C}$	PRQ-317
Calculated offset on IL when IS= 0 A at Tj = 150°C	$I_{L0}$	-30	0	30	mA	$V_S - V_{IS} \geq \text{Min}(V_S - V_{IS})$ $T_J = 150^\circ\text{C}$	PRQ-318
Calculated offset on IS when IL = 0 A at Tj = -40°C	$I_{IS0}$	-1.37	0	1.59	$\mu\text{A}$	<sup>1)</sup> $V_S - V_{IS} \geq \text{Min}(V_S - V_{IS})$ $T_J = -40^\circ\text{C}$	PRQ-319
Calculated offset on IS when IL = 0 A at Tj = 25°C	$I_{IS0}$	-1.10	0	1.27	$\mu\text{A}$	<sup>1)</sup> $V_S - V_{IS} \geq \text{Min}(V_S - V_{IS})$ $T_J = 25^\circ\text{C}$	PRQ-320
Calculated offset on IS when IL = 0 A at Tj = 150°C	$I_{IS0}$	-0.83	0	0.96	$\mu\text{A}$	<sup>1)</sup> $V_S - V_{IS} \geq \text{Min}(V_S - V_{IS})$ $T_J = 150^\circ\text{C}$	PRQ-321
Current sense ratio spread over temperature and repetitive pulse operation	$\Delta(k_{ILIS(\text{CAL})})$	-5	0	+5	%	<sup>1)</sup>	PRQ-168

**(table continues...)**

5 Functional description

**Table 6 (continued) Electrical characteristics table**

$V_S = 12\text{ V to } 54\text{ V}$ ,  $T_J = -40^\circ\text{C to } +150^\circ\text{C}$  unless otherwise specified. For a given temperature or voltage range, typical values are specified at  $V_S = 48\text{ V}$ ,  $T_J = 25^\circ\text{C}$ .

Parameter	Symbol	Values			Unit	Note or condition	P-Number
		Min.	Typ.	Max.			

**Diagnosis function in normal conditions**

Current sense settling time until IIS reached final value +/-3%	$t_{sIS(IN\_ON)}$	–	800	1700	$\mu\text{s}$	$R_L = R_{L(NOM)}$	PRQ-169
Current sense settling time until IIS reached final value +/-3% after activation of DEN	$t_{sIS(DEN\_ON)}$	0	25	85	$\mu\text{s}$	$V_S - V_{IS} \geq 5\text{V}$ $R_L = R_{L(NOM)}$	PRQ-172
Current sense disable time	$t_{sIS(DEN\_OFF)}$	0	10	20	$\mu\text{s}$	From DEN falling edge to $I_{IS} = I_{IS(OFF)}$	PRQ-173
Current sense settling time after load change	$t_{sIS(LC)}$	–	40	–	$\mu\text{s}$	<sup>1)</sup> $I_L \geq I_{L0(MAX)}$	PRQ-174
IIS leakage current when IN disabled	$I_{IS(OFF)}$	–	–	1	$\mu\text{A}$	$V_{IN} < V_{I(L)}$ $R_{IS} = 2\text{ k}\Omega$ $T_J \leq 150^\circ\text{C}$	PRQ-175

**Diagnosis function in overload condition**

Sense signal current in fault condition	$I_{IS(FAULT)}$	2.3	3.0	5.2	mA	$(V_S - V_{IS}) \geq 5\text{ V}$ Typical value for $V_S - V_{IS} \geq \text{Min}(V_S - V_{IS})$	PRQ-176
Fault propagation time for over temperature detection	$t_{pIS(FAULT\_OT)}$	–	2.0	3.3	ms	<sup>1)</sup>	PRQ-178
Delay time to reset fault pin after turning off VIN	$t_{IN(RESETDELAY)}$	0.006	–	10	ms	–	PRQ-179

**Diagnosis function: open load detection in off**

Open load detection threshold in off state voltage control	$V_{OUT(OL\_OFF)}$	2.5	3	3.5	V	$V_{IN} < V_{I(L)}$ and $V_{DEN} > V_{I(H)}$	PRQ-180
Fault propagation time for open load detection off during turn off	$t_{pFAULT\_OL(IN\_OFF)}$	–	5	20	$\mu\text{s}$	From falling edge on $V_{IN}$ to $I_{IS(FAULT)}$ on IS pin $V_{DEN} > V_{I(H)}$ $V_{OUT} > V_{OUT(OL\_OFF)}$	PRQ-181
Fault propagation time for open load detection off after activation of DEN	$t_{pFAULT\_OL(DEN\_ON)}$	–	5	20	$\mu\text{s}$	From rising edge on $V_{DEN}$ to $I_{IS(FAULT)}$ on IS pin $V_{IN} < V_{I(L)}$ $V_{OUT} > V_{OUT(OL\_OFF)}$	PRQ-182

(table continues...)

**Table 6 (continued) Electrical characteristics table**

$V_S = 12\text{ V to }54\text{ V}$ ,  $T_J = -40^\circ\text{C to }+150^\circ\text{C}$  unless otherwise specified. For a given temperature or voltage range, typical values are specified at  $V_S = 48\text{ V}$ ,  $T_J = 25^\circ\text{C}$ .

Parameter	Symbol	Values			Unit	Note or condition	P-Number
		Min.	Typ.	Max.			
Disable time of IIS(FAULT) in off condition after deactivation of DEN	$t_{p\text{FAULT\_OL(DEN\_OFF)}}$	–	5	20	$\mu\text{s}$	From falling edge on $V_{\text{DEN}}$ to $I_{\text{S(OFF)}}$ on IS pin $V_{\text{IN}} < V_{\text{I(L)}}$	PRQ-183

1) Not subject to production test, specified by design.

## 6 Typical performance characteristics

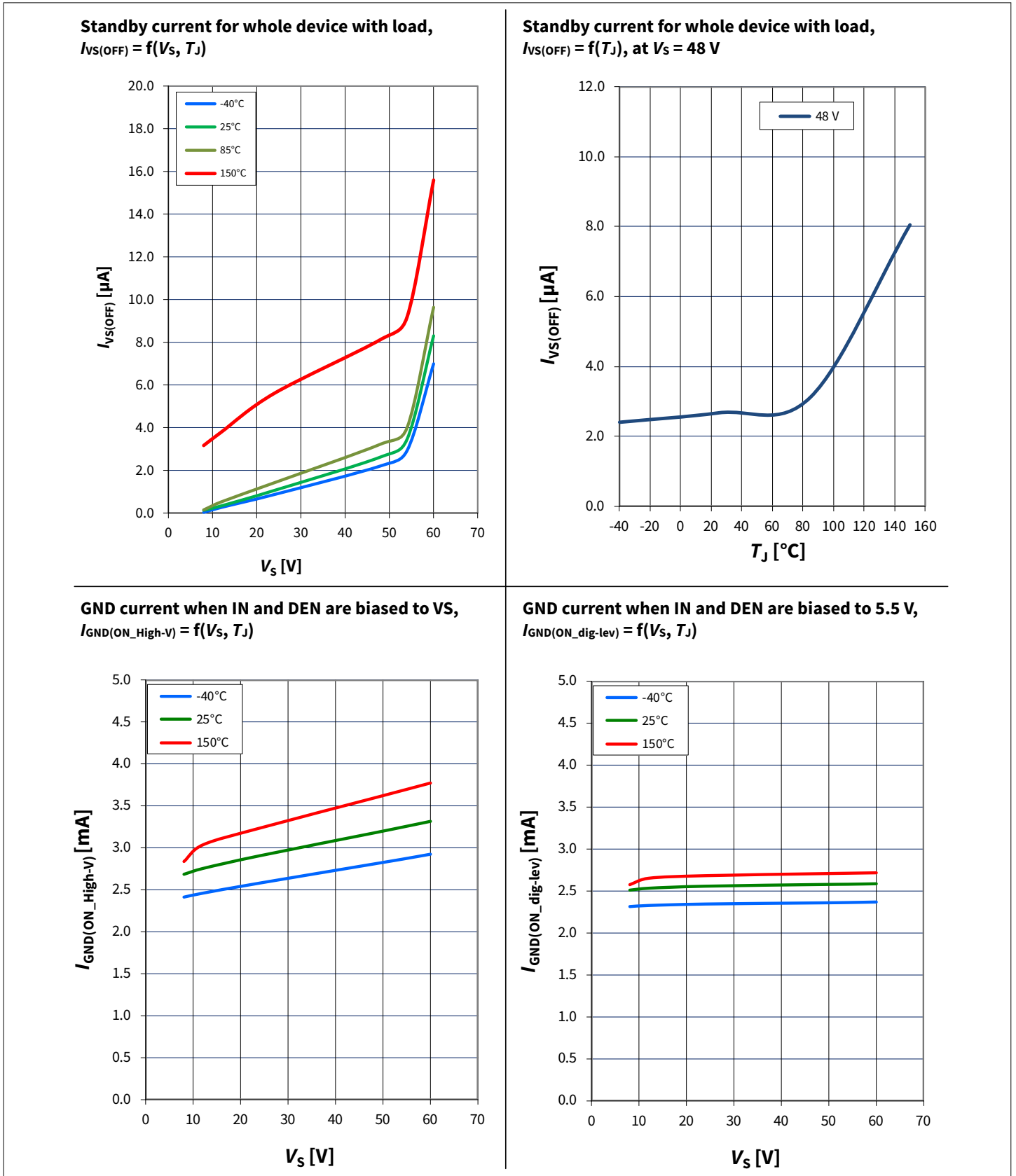

Figure 25 Typical performance characteristics

6 Typical performance characteristics

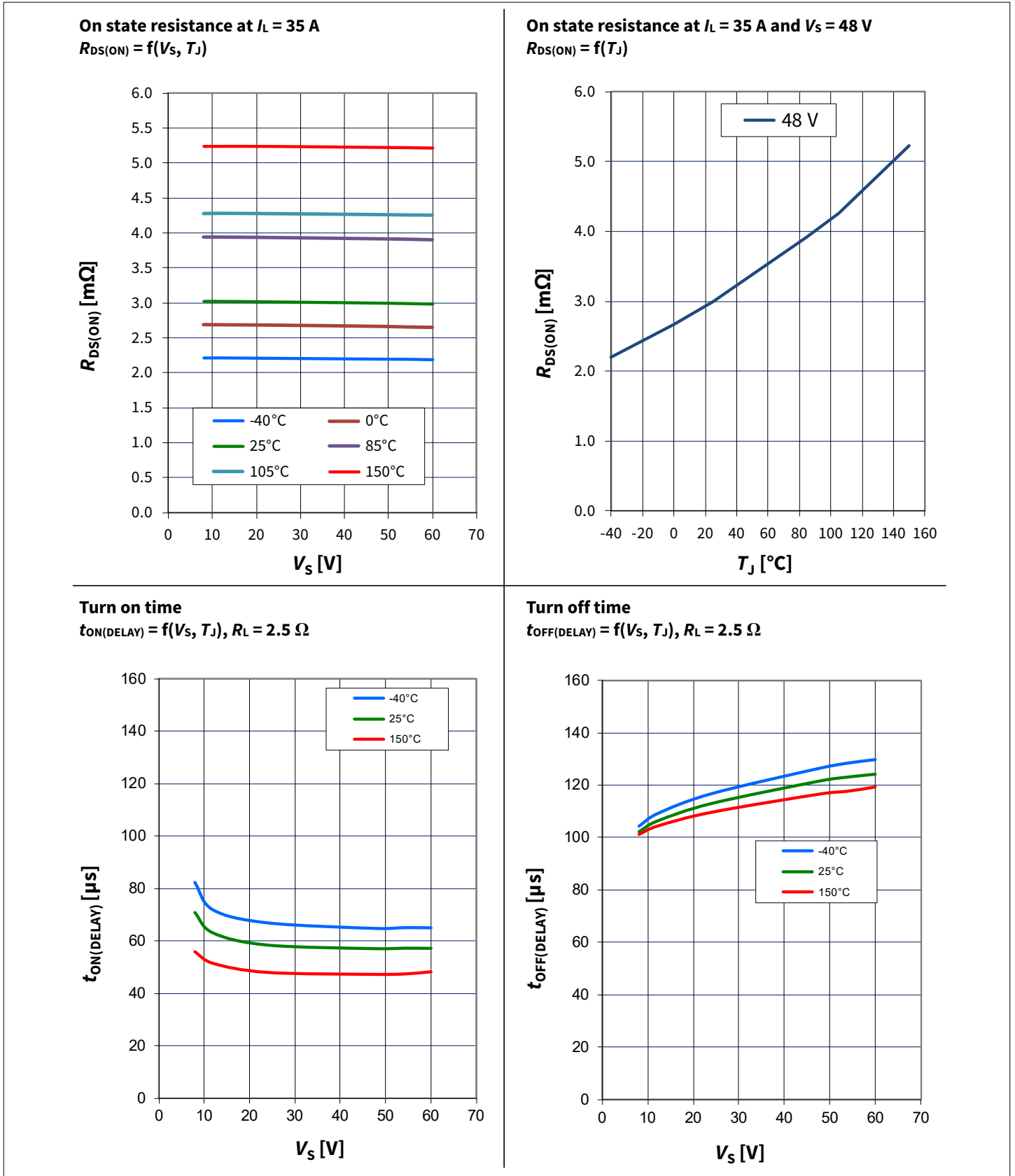
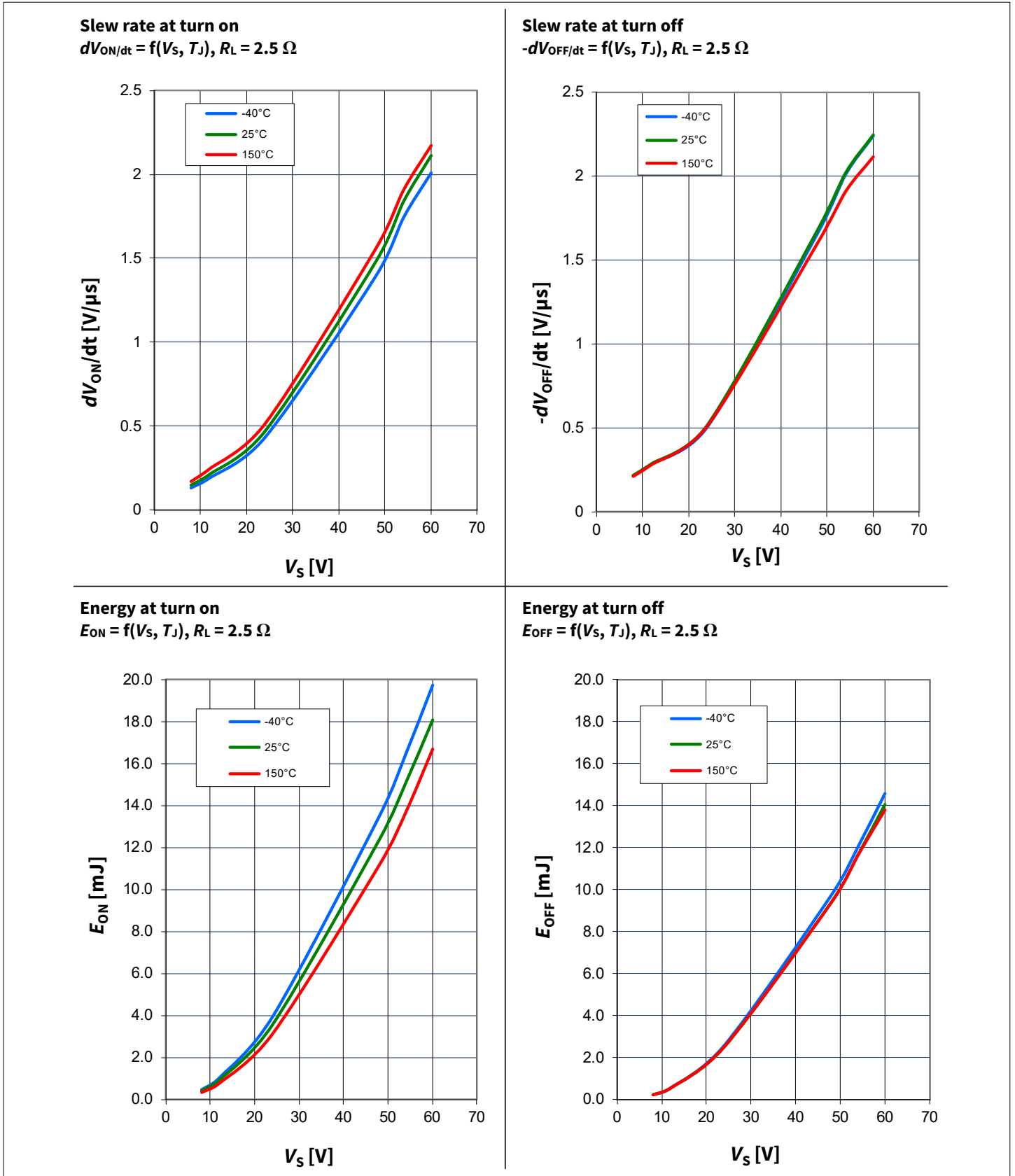

Figure 26 Typical performance characteristics (continued)

6 Typical performance characteristics



**Figure 27** Typical performance characteristics (continued)

6 Typical performance characteristics

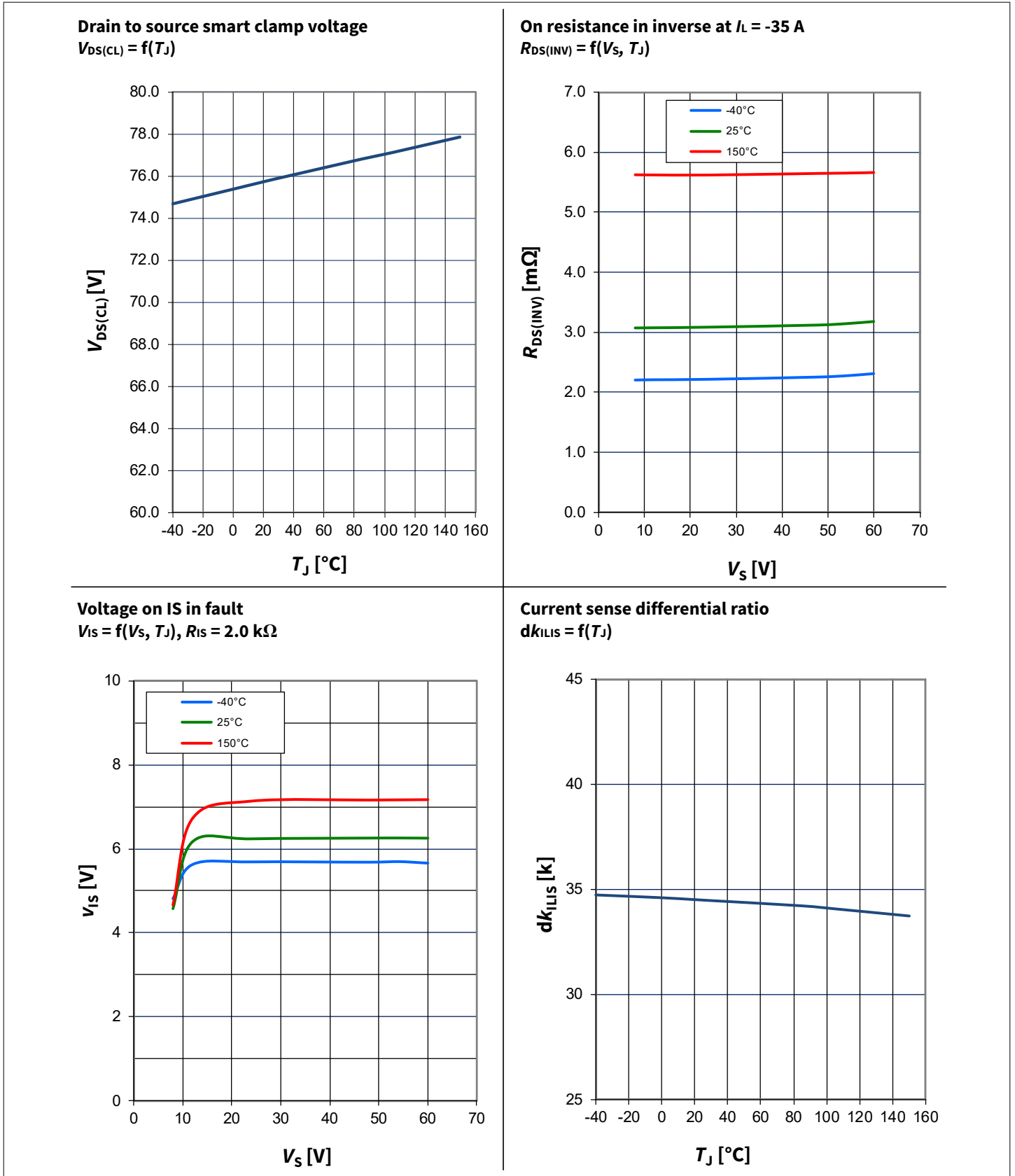
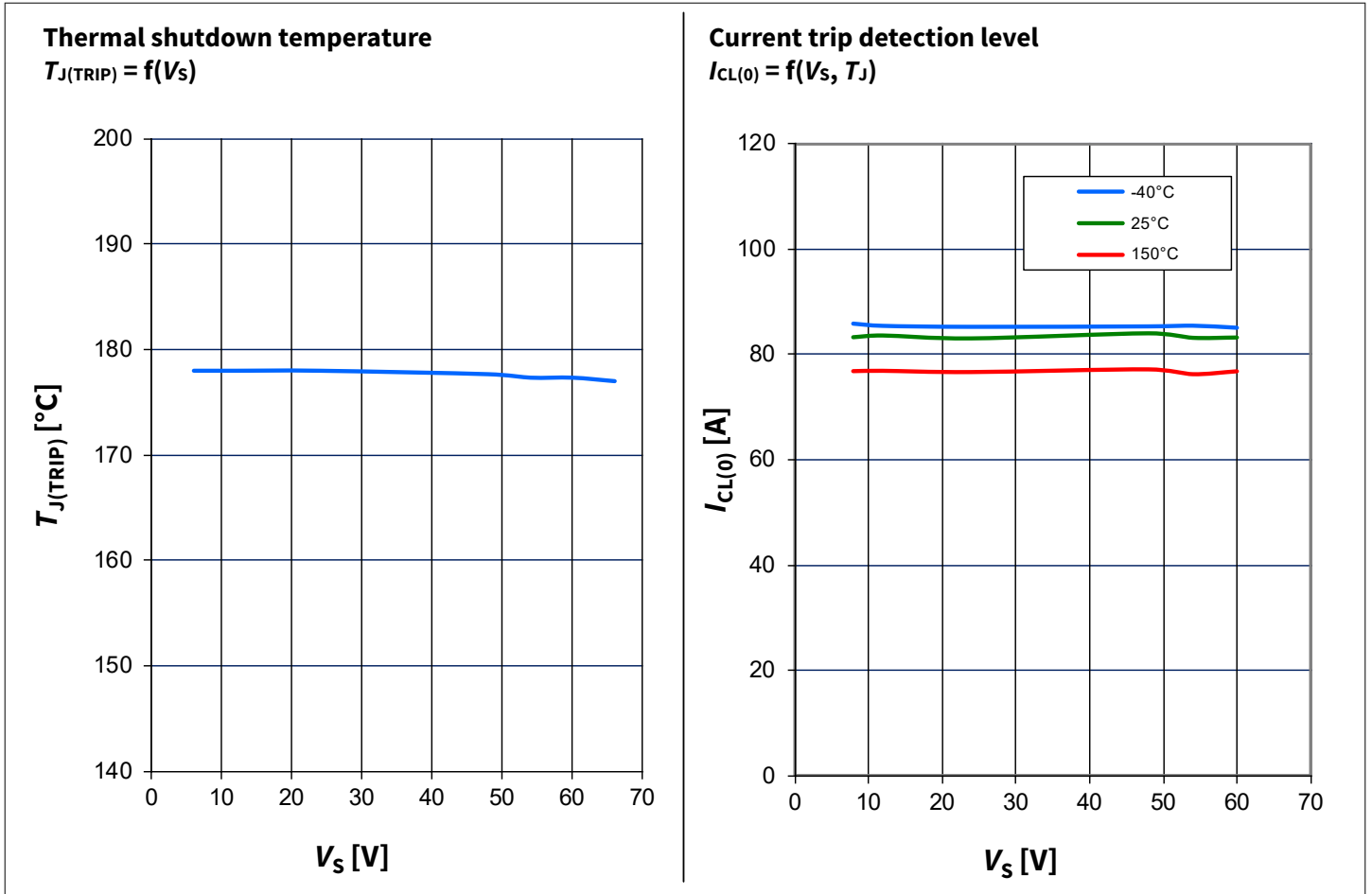

Figure 28 Typical performance characteristics (continued)

6 Typical performance characteristics



**Figure 29** Typical performance characteristics (continued)

## 7 Application information

**Note:** The following information is given as a hint for the implementation of the device only and shall not be regarded as a description or warranty of a certain functionality, condition or quality of the device. These are very simplified examples of an application circuit. The function must be verified in the real application.

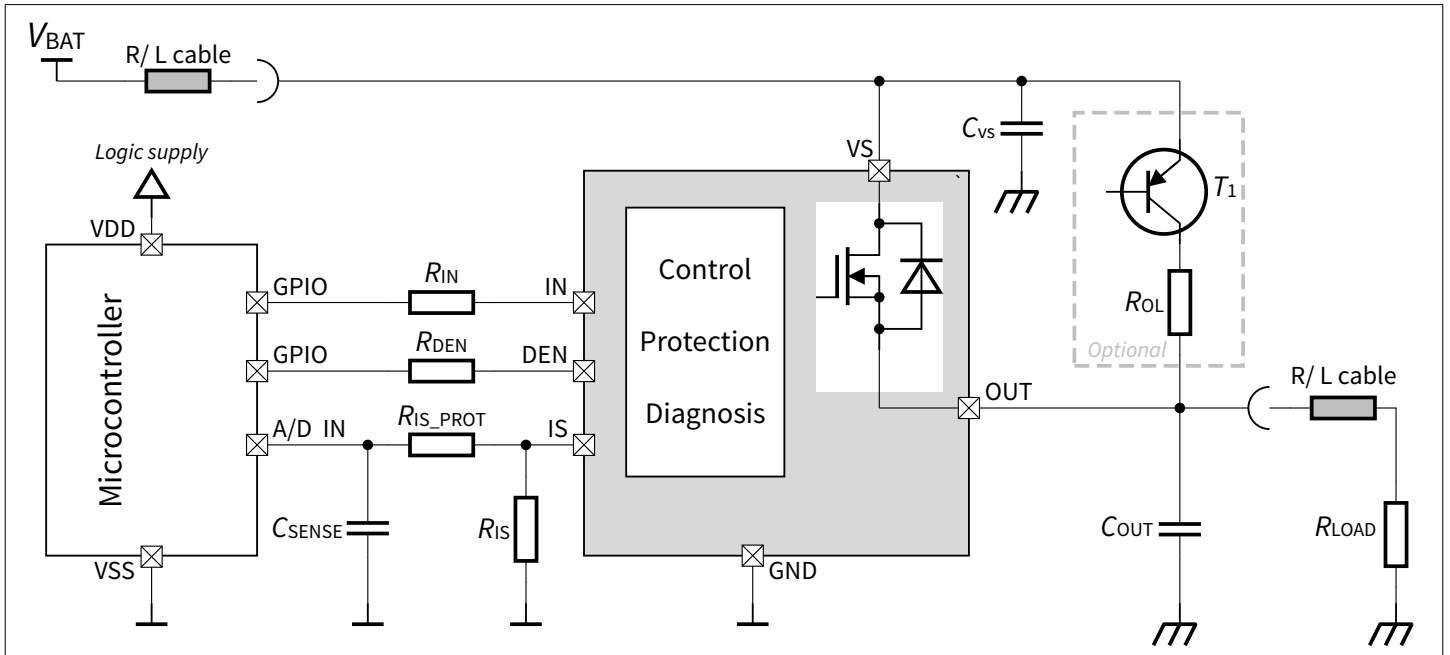

**Figure 30** Application diagram: device controlled by a microcontroller

**Table 7** Bill of material

Reference	Value	Purpose
$R_{IN}$	4.7 k $\Omega$	Protection of the microcontroller
$R_{DEN}$	4.7 k $\Omega$	Protection of the microcontroller
$R_{IS}$	2.0 k $\Omega$	Sense resistor
$R_{IS\_PROT}$	4.7 k $\Omega$	Protection of the microcontroller
$C_{SENSE}$	10 nF	Sense signal filtering
$C_{VS}$	100 nF	Improved EMC behavior (in layout, please place close to the pins)
$C_{OUT}$	47 nF	Protection against EMC
$R_{OL}$	Application specific	Open load detection in off state: to have $V_{OUT}$ higher than $V_{OUT(OL\_OFF)}$ . The value depends on the leakage outside the ECU between OUT and GND

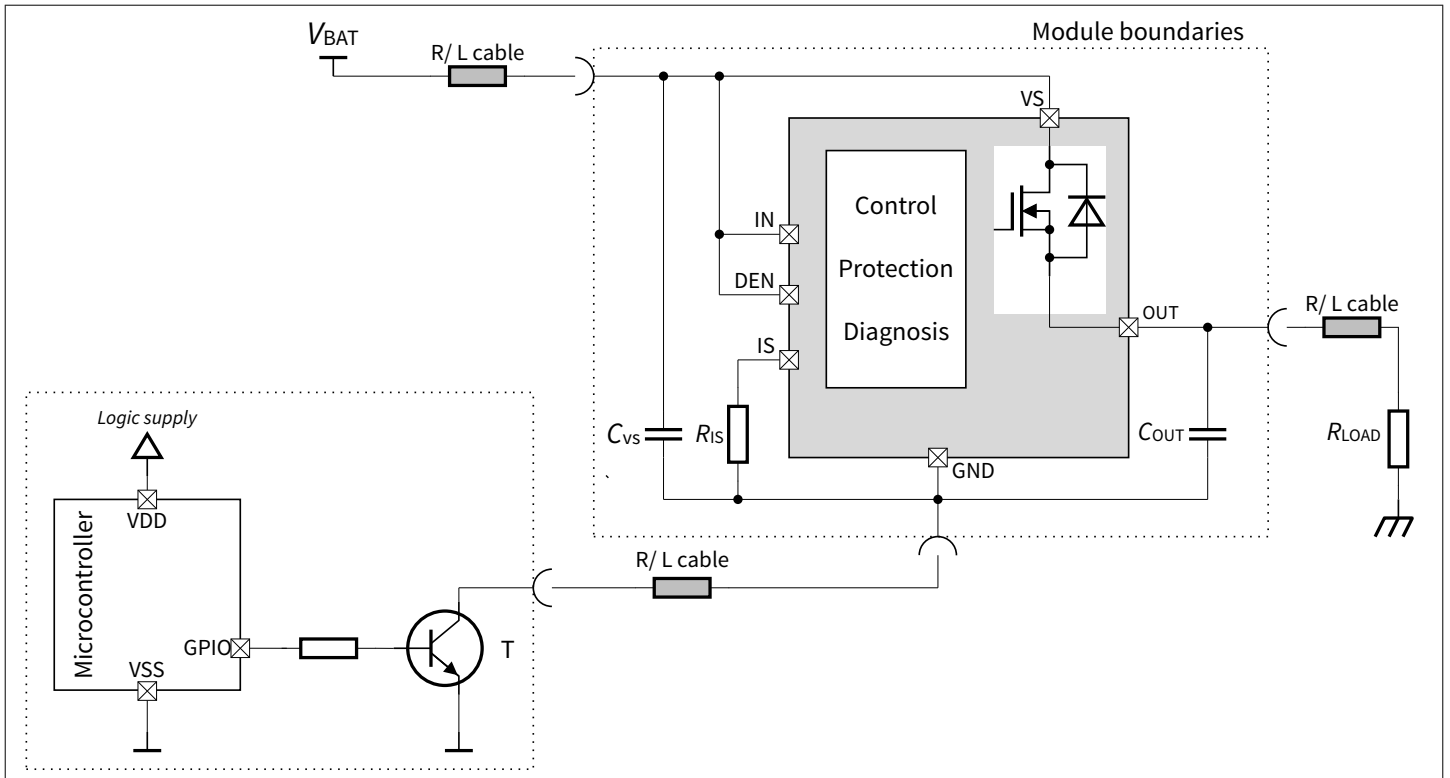

**Figure 31** Application diagram: solid state relay for direct relay replacement

**Table 8** Bill of material

Reference	Value	Purpose
$R_{IS}$	2.0 k $\Omega$	Sense resistor
$C_{VS}$	100 nF	Improved EMC behavior (in layout, please place close to the pins)
$C_{OUT}$	47 nF	Protection against EMC
T	Bipolar or MOSFET	Switch to turn on and off the device

8 Package information

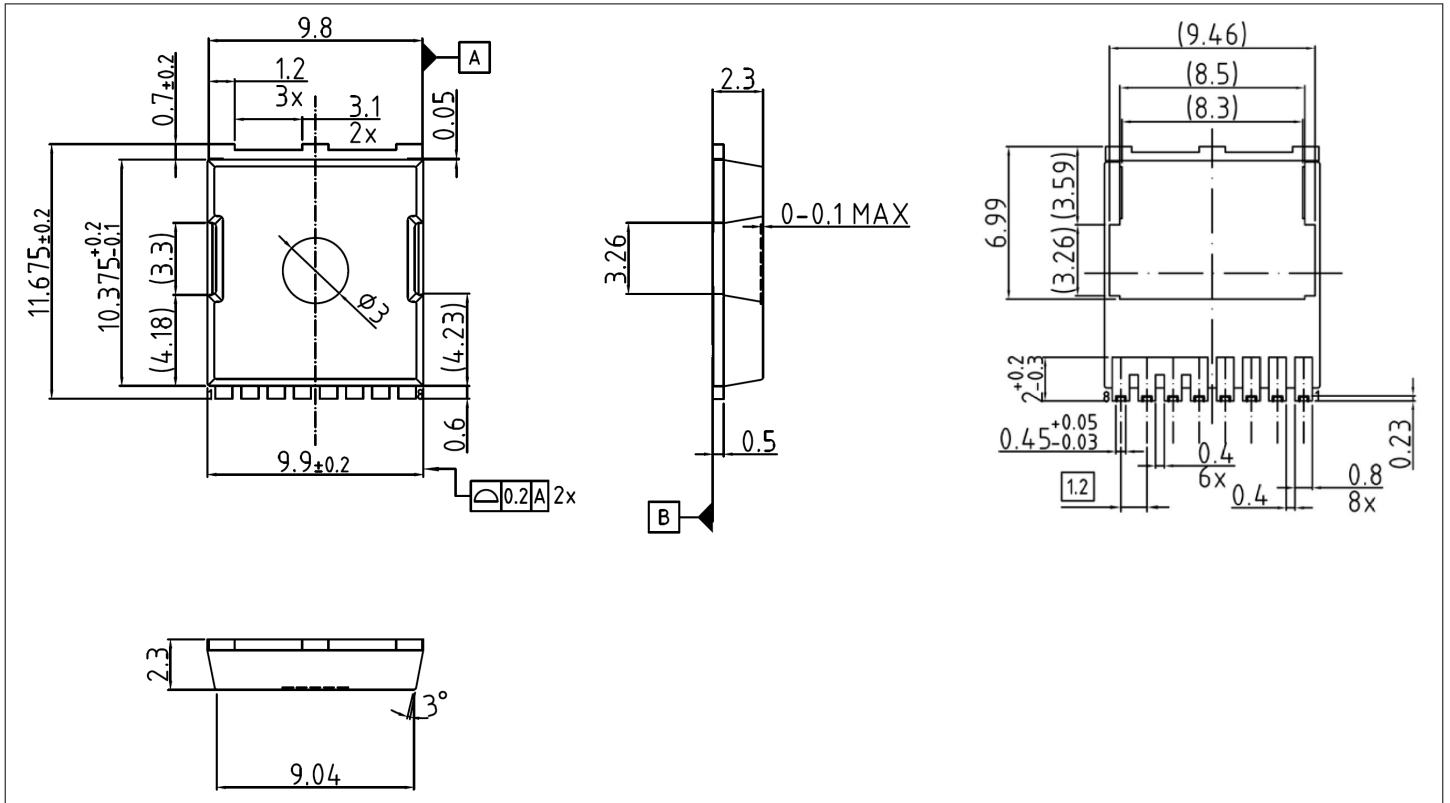

Figure 32 PG-HSOF-8 (8-pin TO-Leadless) package dimensions

**Green Product (RoHS compliant)** To meet the world-wide customer requirements for environmentally friendly products and to be compliant with government regulations the device is available as a green product. Green products are RoHS-Compliant (i.e Pb-free finish on leads and suitable for Pb-free soldering according to IPC/JEDEC J-STD-020).

## 9 Revision history

Revision	Date	Changes
1.00	2023-09-15	Datasheet released
1.01	2024-03-21	Maximum value of the PRQ-93, $I_{OUT(OFF)}$ , changed from 100 $\mu$ A to 50 $\mu$ A
1.10	2024-12-03	<ul style="list-style-type: none"> <li>Note and condition of the PRQ-34 changed to "1) Short term overvoltage according to ISO 21780:2020(E), test-03 <math>R_L = R_{L(NOM)}</math>, <math>R_{IS} = 2 \text{ k}\Omega</math>"</li> <li>Note and condition of the PRQ-55 changed to "1) 2) Parameter deviation possible, long term overvoltage according to ISO 21780:2020(E), test-06"</li> </ul>
1.20	2026-03-15	<ul style="list-style-type: none"> <li>PRQ-55 "Note and condition" changed to "1) 2) Parameter deviation possible"</li> <li>PRQ-55 minimum value changed to 6 V</li> <li>PRQ-381 minimum value changed to 6 V</li> </ul>

## Trademarks

All referenced product or service names and trademarks are the property of their respective owners.

**Edition 2026-03-15**

**Published by**

**Infineon Technologies AG**

**81726 Munich, Germany**

**© 2026 Infineon Technologies AG**

**All Rights Reserved.**

**Do you have a question about any aspect of this document?**

**Email: [erratum@infineon.com](mailto:erratum@infineon.com)**

**Document reference**

**IFX-zsr1569223278552**

## Important notice

The information given in this document shall in no event be regarded as a guarantee of conditions or characteristics ("Beschaffheitsgarantie").

With respect to any examples, hints or any typical values stated herein and/or any information regarding the application of the product, Infineon Technologies hereby disclaims any and all warranties and liabilities of any kind, including without limitation warranties of non-infringement of intellectual property rights of any third party.

In addition, any information given in this document is subject to customer's compliance with its obligations stated in this document and any applicable legal requirements, norms and standards concerning customer's products and any use of the product of Infineon Technologies in customer's applications.

The data contained in this document is exclusively intended for technically trained staff. It is the responsibility of customer's technical departments to evaluate the suitability of the product for the intended application and the completeness of the product information given in this document with respect to such application.

## Warnings

Due to technical requirements products may contain dangerous substances. For information on the types in question please contact your nearest Infineon Technologies office.

Except as otherwise explicitly approved by Infineon Technologies in a written document signed by authorized representatives of Infineon Technologies, Infineon Technologies' products may not be used in any applications where a failure of the product or any consequences of the use thereof can reasonably be expected to result in personal injury.