

最终数据手册

英飞凌 CoolSiC™ 1200 V 碳化硅沟道 MOSFET

特性

- $T_{vj} = -55 \dots 175^\circ\text{C}$ 时 $V_{DSS} = 1200\text{ V}$
- $T_C = 25^\circ\text{C}$ 时 $I_{Dc} = 69\text{ A}$
- 新的性能优化芯片技术 (Gen1p), 改善了 $R_{Dson} \cdot A$ FOM
- 提高了建议开启电压 ($V_{GS(on)} = 20\text{ V}$) 以降低 $R_{DS(on)}$
- 业界领先的开关能量特性, 可降低开关损耗并减少冷却需求
- 最低的器件电容值, 可实现更高的开关速度和更高的功率密度
- 低 C_{rss}/C_{iss} 电容比值和高 $V_{GS(th)}$ 的组合, 可避免寄生导通并实现单极性栅极驱动
- 降低了总栅极电荷 Q_{Gtot} , 可降低驱动功率和损耗
- .XT 芯片粘接技术, 实现业界领先的热性能
- 用于优化开关性能的检测引脚
- 最小爬电距离为 7.07 毫米, 以满足高压要求

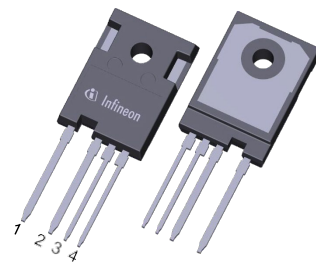

- Halogen-free
- Green
- Lead-free
- RoHS
- AEC-Q100/101 Qualified

潜在应用

- 车载充电器
- 直流/直流转换器
- 辅助驱动

产品验证

- 适合汽车应用。根据 AEC-Q100/101 进行产品验证

描述

引脚定义:

- 1 - 漏极
- 2 - 来源
- 3 - 开尔文检测
- 4 - 栅极

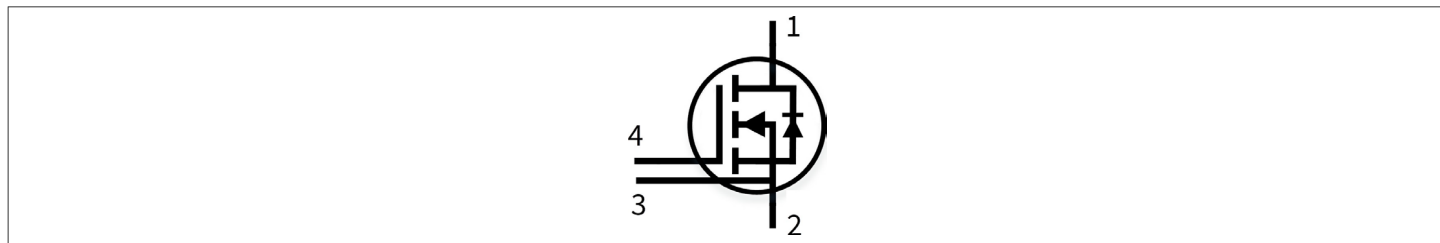

Type	Package	Marking
AIMZH120R030M1T	PG-TO247-4-U03	A12M1T030

本数据手册的原文使用英文撰写。为方便起见, 英飞凌提供了译文; 由于翻译过程中可能使用了自动化工具, 英飞凌不保证译文的准确性。为确认准确性, 请务必访问 infineon.com 参考最新的英文版本 (控制文档)。

目录

	描述.....	1
	特性.....	1
	潜在应用	1
	产品验证	1
	目录.....	2
1	封装.....	3
2	MOSFET	3
3	体二极管 (MOSFET)	5
4	特性图	7
5	封装外形	13
6	测试条件	14
	修订记录	15
	免责声明	16

1 封装

1 封装

表 1 特征值

Parameter	Symbol	Note or test condition	Values			Unit
			Min.	Typ.	Max.	
Storage temperature	T_{stg}		-55		150	°C
Soldering temperature	T_{sold}				260	°C
MOSFET/body diode thermal resistance, junction-case ¹⁾	$R_{th(j-c)}$			0.35	0.46	K/W

1) 未经过生产测试。该参数已通过设计/特性验证

2 MOSFET

表 2 最大额定值

Parameter	Symbol	Note or test condition	Values	Unit	
Drain-source voltage ¹⁾	V_{DSS}	$T_{vj} = -55...175\text{ °C}$	1200	V	
Continuous DC drain current for $R_{th(j-c,max)}$, limited by $T_{vj(max)}$ ²⁾	I_{DCC}	$V_{GS} = 20\text{ V}$	$T_c = 25\text{ °C}$	69	A
			$T_c = 100\text{ °C}$	49	
Peak drain current, t_p limited by $T_{vj(max)}$ ²⁾	I_{DM}	$V_{GS} = 20\text{ V}$	176	A	
Gate-source voltage, max. transient voltage ³⁾	V_{GS}	$t_p \leq 0.5\ \mu\text{s}, D < 0.01$	-10...25	V	
Gate-source voltage, max. static voltage ³⁾	V_{GS}		-5...23	V	
Avalanche energy, single pulse	E_{AS}	$I_D = 20\text{ A}, V_{DD} = 50\text{ V}, L = 1.8\text{ mH}$	361	mJ	
Power dissipation, limited by $T_{vj(max)}$ ²⁾	P_{tot}		$T_c = 25\text{ °C}$	326	W
			$T_c = 100\text{ °C}$	163	

1) 在 $T_{vj}=25\text{ °C}$ 下进行测试，并通过全温度范围内的设计/特性验证

2) 未经过生产测试。该参数已通过设计/特性验证

3) **重要注释：** 正负栅极源电压的选择会影响器件的长期行为。为了确保器件在计划使用寿命内的正常运行，必须考虑应用说明 AN2018-09 中描述的设计指南。

表 3 建议值

Parameter	Symbol	Note or test condition	Values	Unit
Recommended turn-on gate voltage	$V_{GS(on)}$		20	V
Recommended turn-off gate voltage	$V_{GS(off)}$		0	V

表 4 特征值

Parameter	Symbol	Note or test condition	Values			Unit	
			Min.	Typ.	Max.		
Drain-source on-state resistance	$R_{DS(on)}$	$I_D = 27\text{ A}$	$T_{vj} = 25\text{ °C}$, $V_{GS(on)} = 20\text{ V}$		30	38	mΩ
			$T_{vj} = 100\text{ °C}$, $V_{GS(on)} = 20\text{ V}$		42		
			$T_{vj} = 175\text{ °C}$, $V_{GS(on)} = 20\text{ V}$		60		
			$T_{vj} = 25\text{ °C}$, $V_{GS(on)} = 18\text{ V}$		33		
Gate-source threshold voltage	$V_{GS(th)}$	$I_D = 8.6\text{ mA}$, $V_{DS} = V_{GS}$ (tested after 1 ms pulse at $V_{GS} = 20\text{ V}$)	$T_{vj} = 25\text{ °C}$	3.7	4.4	5.1	V
			$T_{vj} = 175\text{ °C}$		3.6		
Zero gate-voltage drain current	I_{DSS}	$V_{DS} = 1200\text{ V}$, $V_{GS} = 0\text{ V}$	$T_{vj} = 25\text{ °C}$		0.4	26	μA
			$T_{vj} = 175\text{ °C}$		50		
Gate leakage current	I_{GSS}	$V_{DS} = 0\text{ V}$	$V_{GS} = 25\text{ V}$			100	nA
			$V_{GS} = -10\text{ V}$			-100	
Forward transconductance	g_{fs}	$I_D = 27\text{ A}$, $V_{DS} = 20\text{ V}$			16.5		S
Short-circuit withstand time ¹⁾	t_{SC}	$V_{DD} \leq 800\text{ V}$, $V_{DS,peak} < 1200\text{ V}$, $T_{vj(start)} = 25\text{ °C}$, $R_{G,ext} = 2\text{ }\Omega$	$V_{GS(on)} = 20\text{ V}$		1.5		μs
			$V_{GS(on)} = 18\text{ V}$		2		
			$V_{GS(on)} = 15\text{ V}$		2.5		
Internal gate resistance	$R_{G,int}$	$f = 1\text{ MHz}$, $V_{AC} = 25\text{ mV}$			2.6		Ω
Input capacitance	C_{iss}	$V_{DS} = 800\text{ V}$, $V_{GS} = 0\text{ V}$, $f = 100\text{ kHz}$, $V_{AC} = 25\text{ mV}$			1738		pF
Output capacitance	C_{oss}	$V_{DS} = 800\text{ V}$, $V_{GS} = 0\text{ V}$, $f = 100\text{ kHz}$, $V_{AC} = 25\text{ mV}$			82		pF
Reverse transfer capacitance	C_{rss}	$V_{DS} = 800\text{ V}$, $V_{GS} = 0\text{ V}$, $f = 100\text{ kHz}$, $V_{AC} = 25\text{ mV}$			4.4		pF
C_{oss} stored energy	E_{oss}	$V_{DS} = 800\text{ V}$, $V_{GS} = 0\text{ V}$, $f = 100\text{ kHz}$, $V_{AC} = 25\text{ mV}$			34		μJ
Total gate charge	Q_G	$V_{DD} = 800\text{ V}$, $I_D = 27\text{ A}$, $V_{GS} = 0/20\text{ V}$, turn-on pulse			57		nC
Plateau gate charge	$Q_{GS(pl)}$	$V_{DD} = 800\text{ V}$, $I_D = 27\text{ A}$, $V_{GS} = 0/20\text{ V}$, turn-on pulse			15		nC
Gate-drain charge	Q_{GD}	$V_{DD} = 800\text{ V}$, $I_D = 27\text{ A}$, $V_{GS} = 0/20\text{ V}$, turn-on pulse			10		nC
Turn-on delay time	$t_{d(on)}$	$V_{DD} = 800\text{ V}$, $I_D = 27\text{ A}$, $V_{GS} = 0/20\text{ V}$, $R_{GS(on)} = 2\text{ }\Omega$, $R_{GS(off)} = 2\text{ }\Omega$, $L_\sigma = 33\text{ nH}$	$T_{vj} = 25\text{ °C}$		11		ns
			$T_{vj} = 175\text{ °C}$		11		

(表格续下页.....)

表 4 (续) 特征值

Parameter	Symbol	Note or test condition	Values			Unit
			Min.	Typ.	Max.	
Rise time	t_r	$V_{DD} = 800 \text{ V}, I_D = 27 \text{ A},$ $V_{GS} = 0/20 \text{ V},$ $R_{GS(on)} = 2 \Omega,$ $R_{GS(off)} = 2 \Omega, L_\sigma = 33 \text{ nH}$	$T_{vj} = 25 \text{ }^\circ\text{C}$	9		ns
			$T_{vj} = 175 \text{ }^\circ\text{C}$	12		
Turn-off delay time	$t_{d(off)}$	$V_{DD} = 800 \text{ V}, I_D = 27 \text{ A},$ $V_{GS} = 0/20 \text{ V},$ $R_{GS(on)} = 2 \Omega,$ $R_{GS(off)} = 2 \Omega, L_\sigma = 33 \text{ nH}$	$T_{vj} = 25 \text{ }^\circ\text{C}$	21		ns
			$T_{vj} = 175 \text{ }^\circ\text{C}$	22		
Fall time	t_f	$V_{DD} = 800 \text{ V}, I_D = 27 \text{ A},$ $V_{GS} = 0/20 \text{ V},$ $R_{GS(on)} = 2 \Omega,$ $R_{GS(off)} = 2 \Omega, L_\sigma = 33 \text{ nH}$	$T_{vj} = 25 \text{ }^\circ\text{C}$	10		ns
			$T_{vj} = 175 \text{ }^\circ\text{C}$	10		
Turn-on energy	E_{on}	$V_{DD} = 800 \text{ V}, I_D = 27 \text{ A},$ $V_{GS} = 0/20 \text{ V},$ $R_{GS(on)} = 2 \Omega,$ $R_{GS(off)} = 2 \Omega, L_\sigma = 33 \text{ nH}$	$T_{vj} = 25 \text{ }^\circ\text{C}$	155		μJ
			$T_{vj} = 175 \text{ }^\circ\text{C}$	319		
Turn-off energy	E_{off}	$V_{DD} = 800 \text{ V}, I_D = 27 \text{ A},$ $V_{GS} = 0/20 \text{ V},$ $R_{GS(on)} = 2 \Omega,$ $R_{GS(off)} = 2 \Omega, L_\sigma = 33 \text{ nH}$	$T_{vj} = 25 \text{ }^\circ\text{C}$	70		μJ
			$T_{vj} = 175 \text{ }^\circ\text{C}$	73		
Total switching energy	E_{tot}	$V_{DD} = 800 \text{ V}, I_D = 27 \text{ A},$ $V_{GS} = 0/20 \text{ V},$ $R_{GS(on)} = 2 \Omega,$ $R_{GS(off)} = 2 \Omega, L_\sigma = 33 \text{ nH}$	$T_{vj} = 25 \text{ }^\circ\text{C}$	225		μJ
			$T_{vj} = 175 \text{ }^\circ\text{C}$	392		
Virtual junction temperature	T_{vj}		-55		175	$^\circ\text{C}$

1) 通过设计/特性验证

注: 动态测试电路参见图F。

除非另有规定, 特性均为 $T_{vj} = 25^\circ\text{C}$ 。

3 体二极管 (MOSFET)

表 5 最大额定值

Parameter	Symbol	Note or test condition	Values	Unit
Drain-source voltage ¹⁾	V_{DSS}	$T_{vj} = -55...175 \text{ }^\circ\text{C}$	1200	V
Continuous reverse drain current for $R_{th(j-c,max)}$, limited by $T_{vj(max)}$ ²⁾	I_{SDC}	$T_c = 25 \text{ }^\circ\text{C}$	60	A
		$T_c = 100 \text{ }^\circ\text{C}$	36	

(表格续下页.....)

表 5 (续) 最大额定值

Parameter	Symbol	Note or test condition	Values			Unit
			Min.	Typ.	Max.	
Peak reverse drain current, t_p limited by $T_{vj(max)}$ ²⁾	I_{SM}		$V_{GS} = 0 V$	61		A
			$-5 V \leq V_{GS} \leq 0 V,$ $t_p = 0.3 \mu s$	80		
			$-5 \leq V_{GS} \leq 0 V, T_{vj} \leq 175^\circ C;$ $t_p \leq 0.3 ms$ for accumulated conduction time < 5 s or $t_p \leq 1 ms$ for accumulated conduction time < 2.5 s ³⁾	207		

1) 在 $T_{vj}=25^\circ C$ 下测试, 通过设计/特性验证

2) 未经过生产测试。该参数已通过设计/特性验证

3) t_p 和 I_{SM} 的组合不应导致 $T_{vj(max)} > 175^\circ C$

表 6 特征值

Parameter	Symbol	Note or test condition	Values			Unit	
			Min.	Typ.	Max.		
Drain-source reverse voltage	V_{SD}	$I_{SD} = 27 A$	$T_{vj} = 25^\circ C$		3.9	5	V
			$T_{vj} = 100^\circ C$		3.8		
			$T_{vj} = 175^\circ C$		3.7		
MOSFET forward recovery charge	Q_{fr}	$V_{DD} = 800 V,$ $I_{SD} = 27 A, V_{GS} = 0 V,$ $-di_{SD}/dt = 2000 A/\mu s, Q_{fr}$ includes also Q_C	$T_{vj} = 25^\circ C$		203		nC
			$T_{vj} = 175^\circ C$		508		
MOSFET peak forward recovery current	I_{frm}	$V_{DD} = 800 V,$ $I_{SD} = 27 A, V_{GS} = 0 V,$ $-di_{SD}/dt = 2000 A/\mu s, Q_{fr}$ includes also Q_C	$T_{vj} = 25^\circ C$		18		A
			$T_{vj} = 175^\circ C$		33		
Virtual junction temperature	T_{vj}		-55		175	$^\circ C$	

4 特性图

Reverse bias safe operating area (RBSOA)

$$I_D = f(V_{DS})$$

$T_{vj} \leq 175\text{ }^\circ\text{C}$, $V_{GS} = 0/20\text{ V}$, $T_c = 25\text{ }^\circ\text{C}$

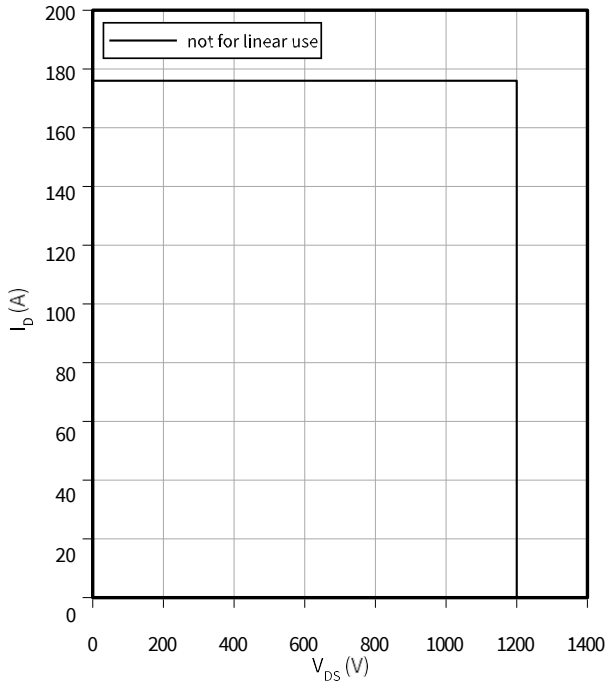

Power dissipation as a function of case temperature

$$P_{tot} = f(T_c)$$

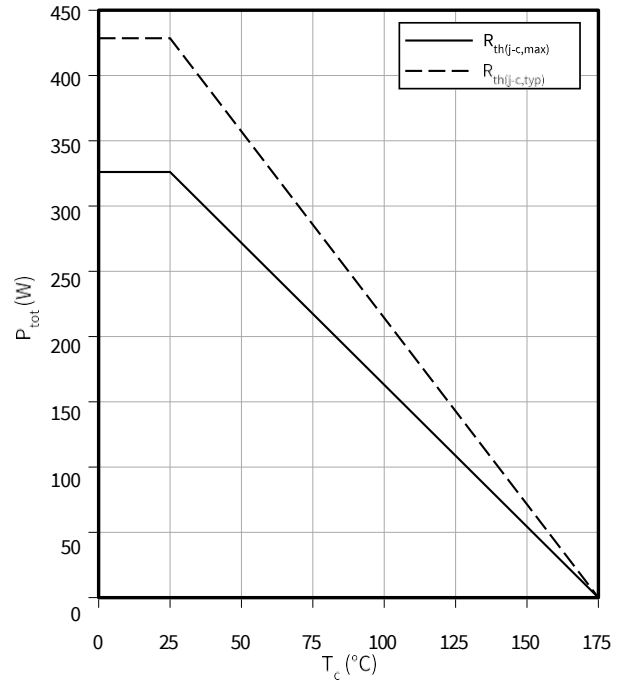

Maximum DC drain to source current as a function of case temperature

$$I_D = f(T_c)$$

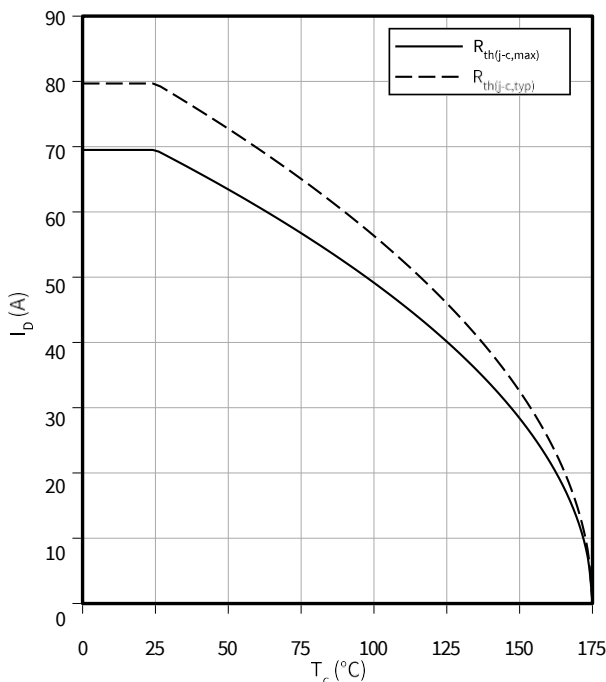

Maximum source to drain current as a function of case temperature

$$I_{SD} = f(T_c)$$

$V_{GS} = 0\text{ V}$

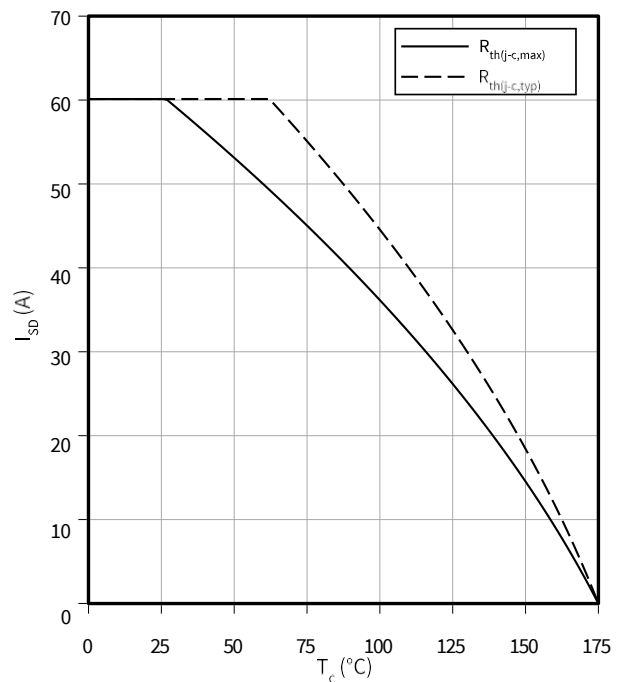

4 特性图

Typical transfer characteristic

$I_D = f(V_{GS})$

$V_{DS} = 20\text{ V}$, $t_p = 20\ \mu\text{s}$

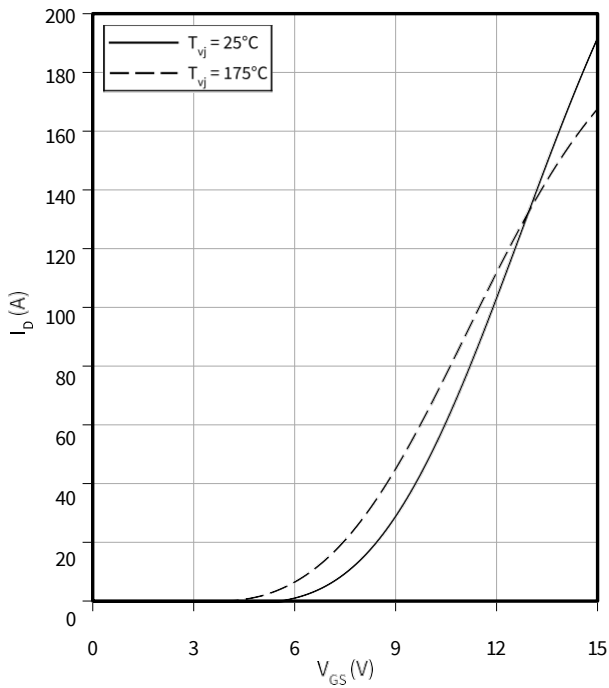

Typical gate-source threshold voltage as a function of junction temperature

$V_{GS(th)} = f(T_{vj})$

$I_D = 8.6\text{ mA}$

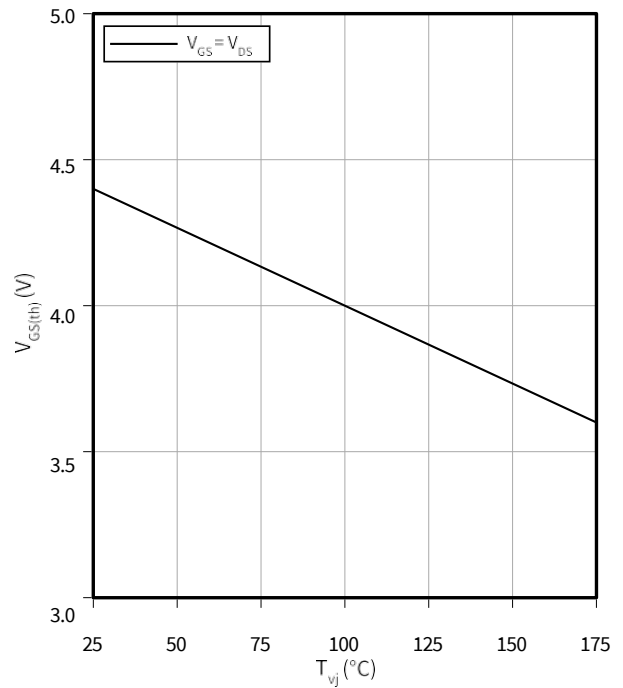

Typical output characteristic, V_{GS} as parameter

$I_D = f(V_{DS})$

$T_{vj} = 25\ ^\circ\text{C}$, $t_p = 20\ \mu\text{s}$

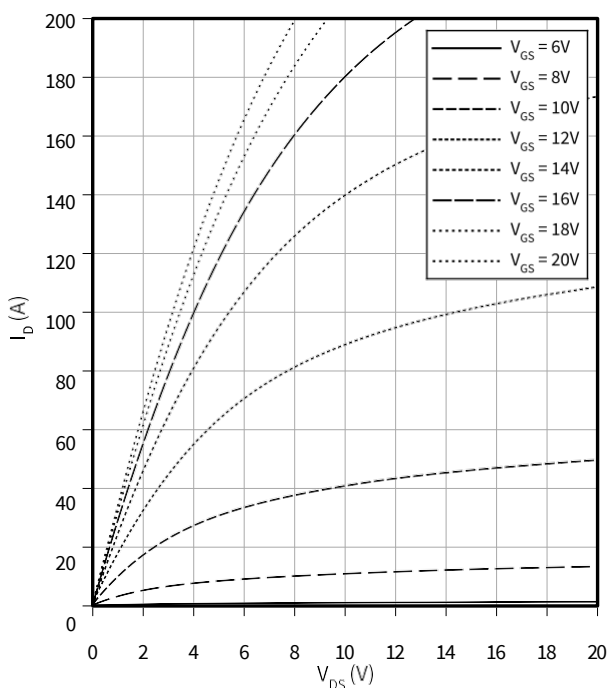

Typical output characteristic, V_{GS} as parameter

$I_D = f(V_{DS})$

$T_{vj} = 175\ ^\circ\text{C}$, $t_p = 20\ \mu\text{s}$

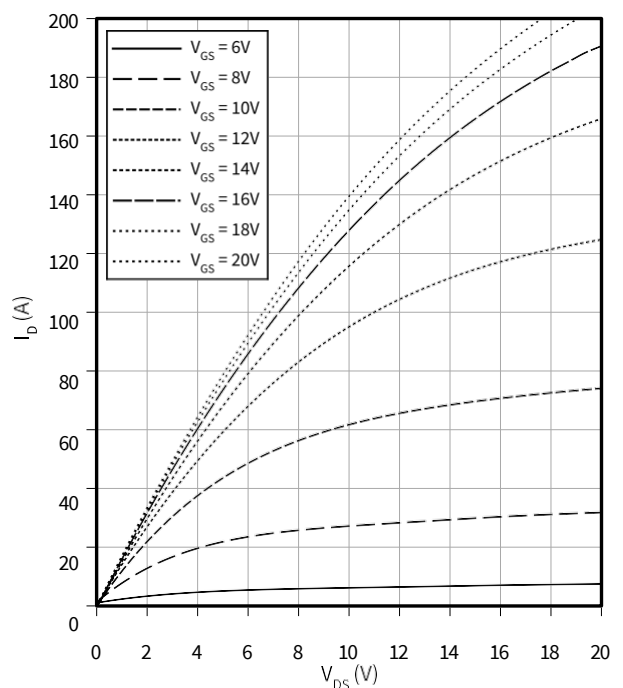

4 特性图

Typical on-state resistance as a function of junction temperature

$R_{DS(on)} = f(T_{vj})$

$I_D = 27\text{ A}$

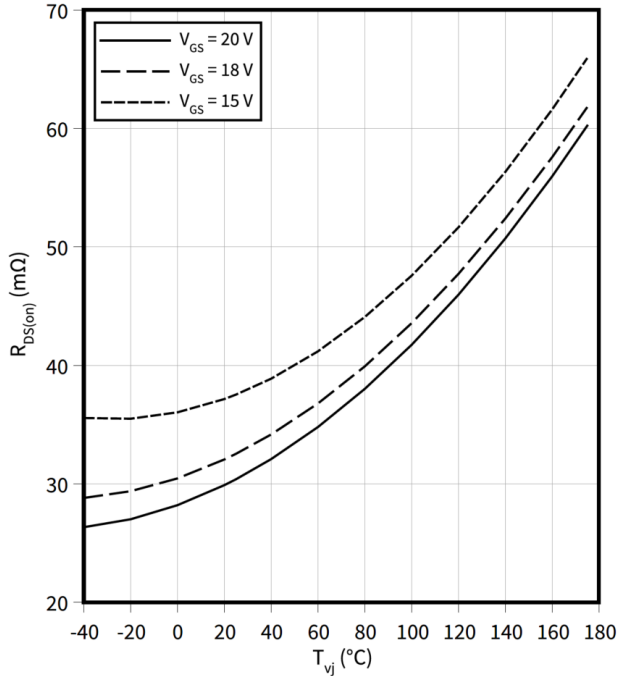

Typical gate charge

$V_{GS} = f(Q_G)$

$I_D = 27\text{ A}, V_{DS} = 800\text{ V}$

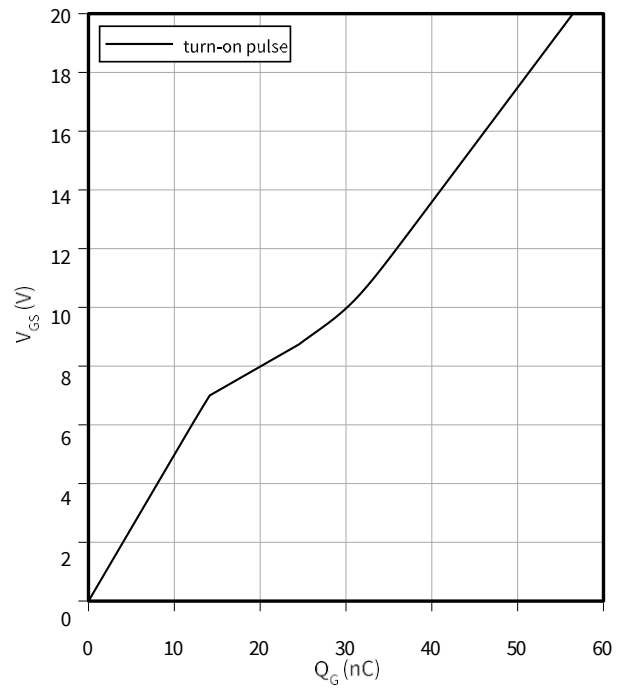

Typical capacitance as a function of drain-source voltage

$C = f(V_{DS})$

$f = 100\text{ kHz}, V_{GS} = 0\text{ V}$

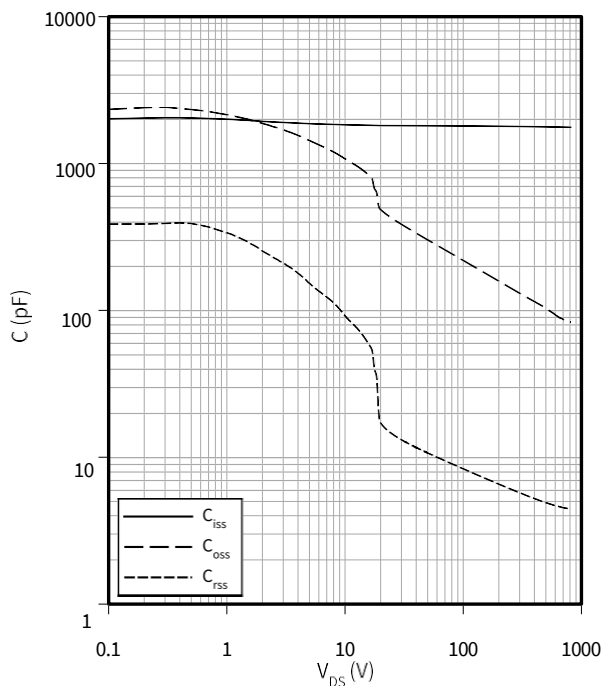

Typical C_{oss} stored energy

$E_{oss} = f(V_{DS})$

$f = 100\text{ kHz}$

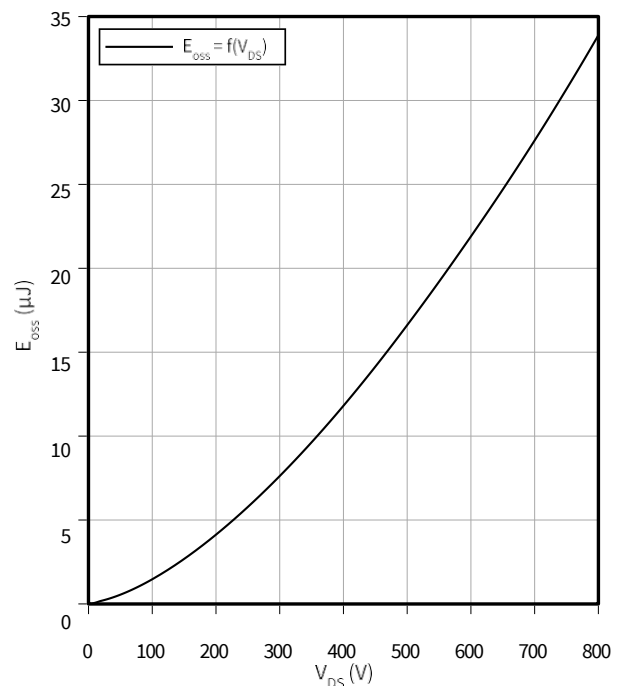

4 特性图

Typical reverse drain voltage as function of junction temperature

$V_{SD} = f(T_{vj})$
 $I_{SD} = 27 \text{ A}, V_{GS} = 0 \text{ V}$

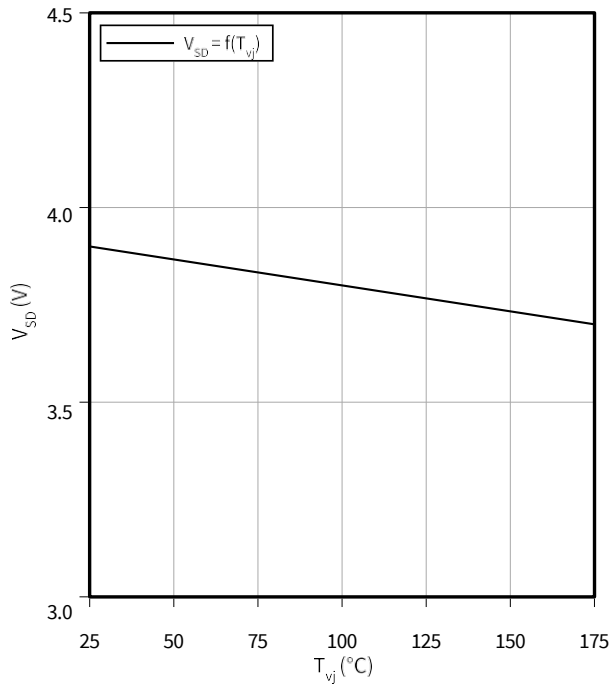

Typical reverse drain current as function of reverse drain voltage, V_{GS} as parameter

$I_{SD} = f(V_{SD})$
 $T_{vj} = 25 \text{ °C}, t_p = 20 \mu\text{s}$

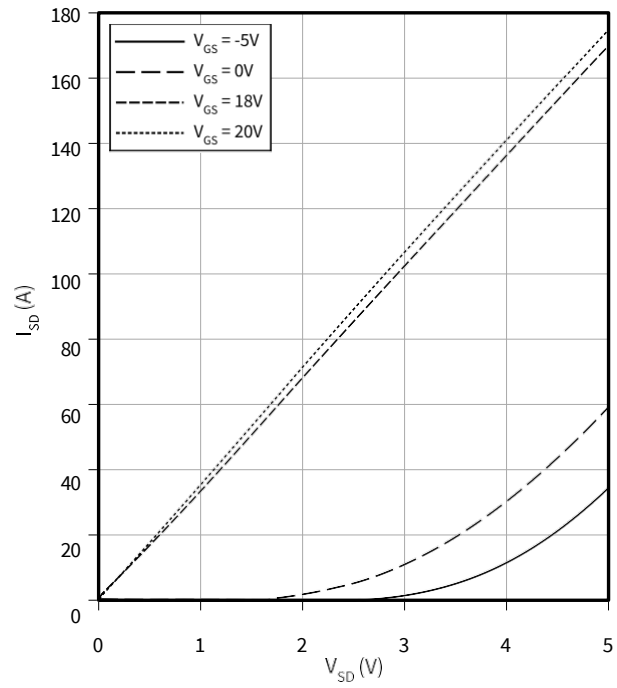

Typical reverse drain current as function of reverse drain voltage, V_{GS} as parameter

$I_{SD} = f(V_{SD})$
 $T_{vj} = 175 \text{ °C}, t_p = 20 \mu\text{s}$

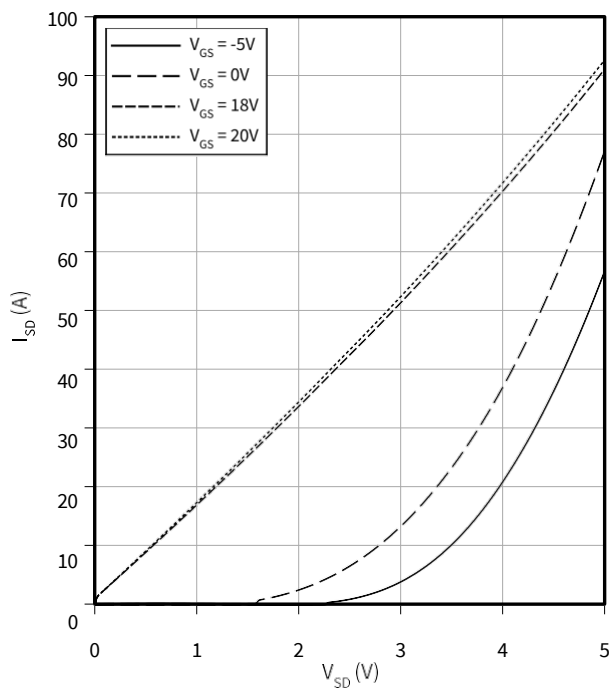

Typical switching energy as a function of junction temperature, test circuit in Fig. F, 2nd device own body diode: $V_{GS} = 0 \text{ V}$

$E = f(T_{vj})$
 $V_{GS} = 0/20 \text{ V}, I_D = 27 \text{ A}, R_{G,ext} = 2 \Omega, V_{DD} = 800 \text{ V}$

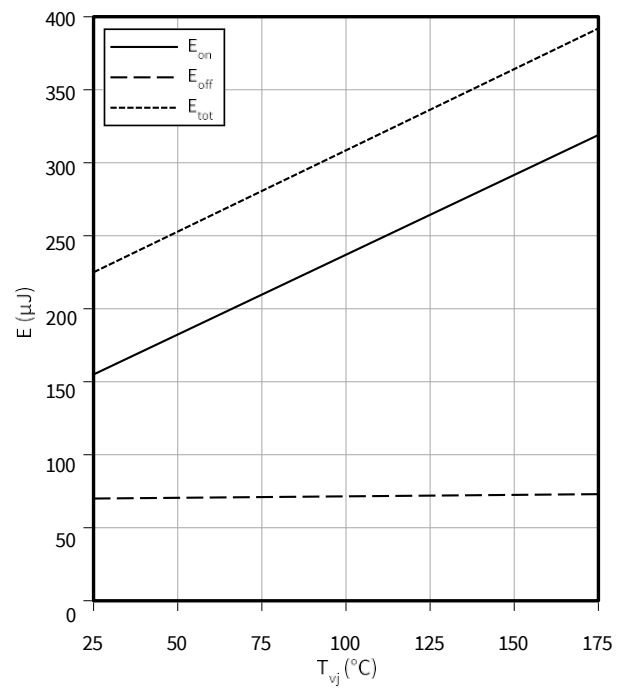

4 特性图

Typical switching energy as a function of drain current, test circuit in Fig. F, 2nd device own body diode: $V_{GS} = 0$ V

$E = f(I_D)$

$V_{GS} = 0/20$ V, $T_{vj} = 175$ °C, $R_{G,ext} = 2$ Ω , $V_{DD} = 800$ V

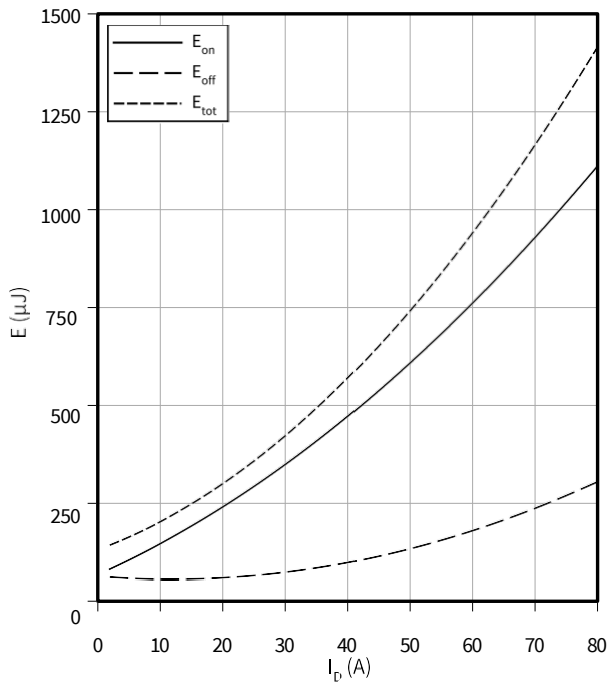

Typical switching energy as a function of drain voltage, test circuit in Fig. F, 2nd device own body diode: $V_{GS} = 0$ V

$E = f(V_{DS})$

$V_{GS} = 0/20$ V, $I_D = 27$ A, $T_{vj} = 175$ °C, $R_{G,ext} = 2$ Ω

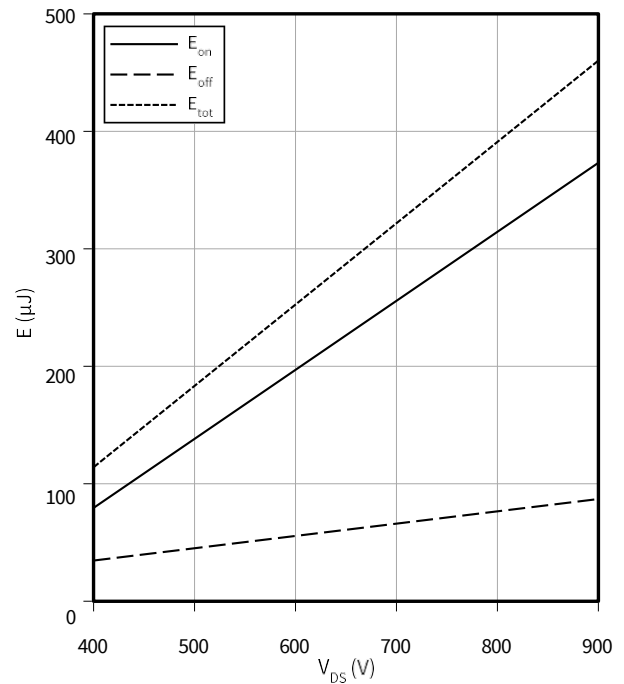

Typical switching energy as a function of gate resistance, test circuit in Fig. F, 2nd device own body diode: $V_{GS} = 0$ V

$E = f(R_{G,ext})$

$V_{GS} = 0/20$ V, $I_D = 27$ A, $T_{vj} = 175$ °C, $V_{DD} = 800$ V

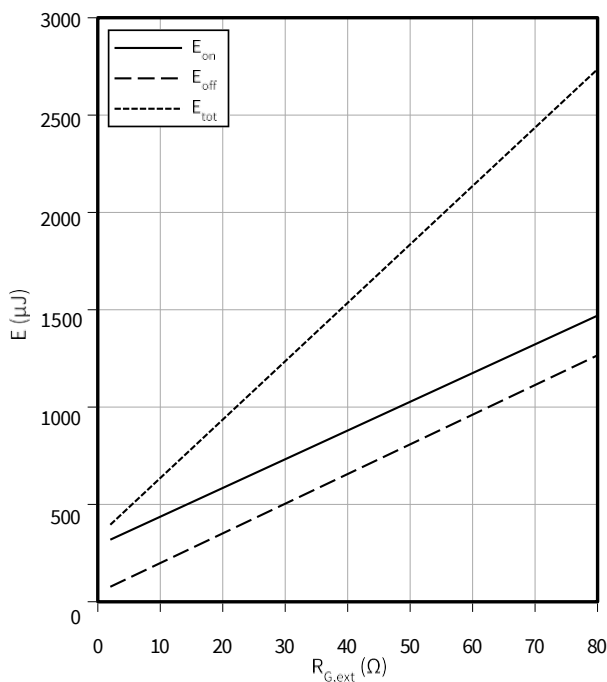

Typical switching times as a function of gate resistance, test circuit in Fig. F, 2nd device own body diode: $V_{GS} = 0$ V

$t = f(R_{G,ext})$

$V_{GS} = 0/20$ V, $I_D = 27$ A, $T_{vj} = 175$ °C, $V_{DD} = 800$ V

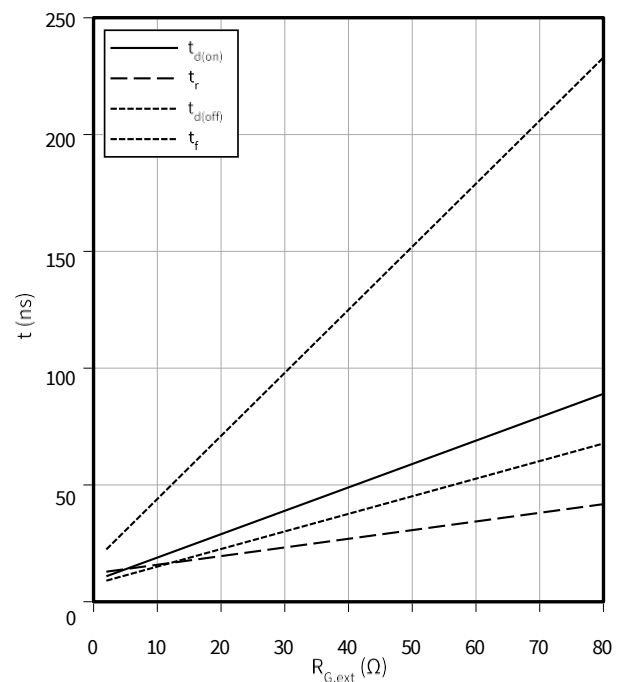

4 特性图

Typical reverse recovery current as a function of reverse drain current slope, test circuit in Fig. F, 2nd device own body diode: $V_{GS} = 0\text{ V}$

$$I_{frm} = f(-di_{SD}/dt)$$

$V_{GS} = 0/20\text{ V}$, $I_{SD} = 27\text{ A}$, $V_{DD} = 800\text{ V}$

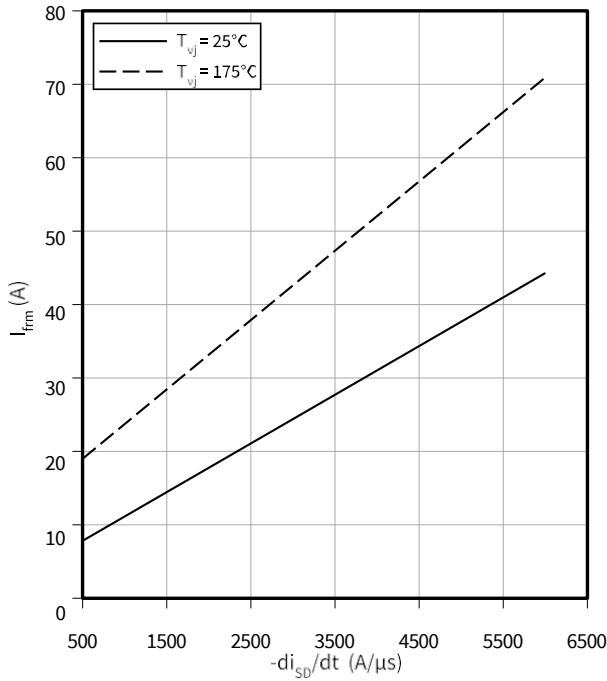

Typ. transient thermal impedance (MOSFET/diode)

$$Z_{th(j-c),typ} = f(t_p)$$

$$D = t_p/T$$

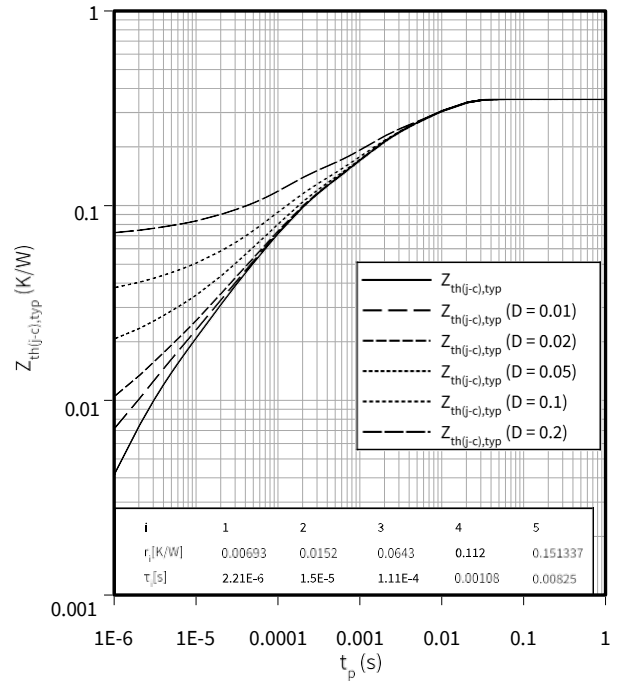

5 封装外形

5 封装外形

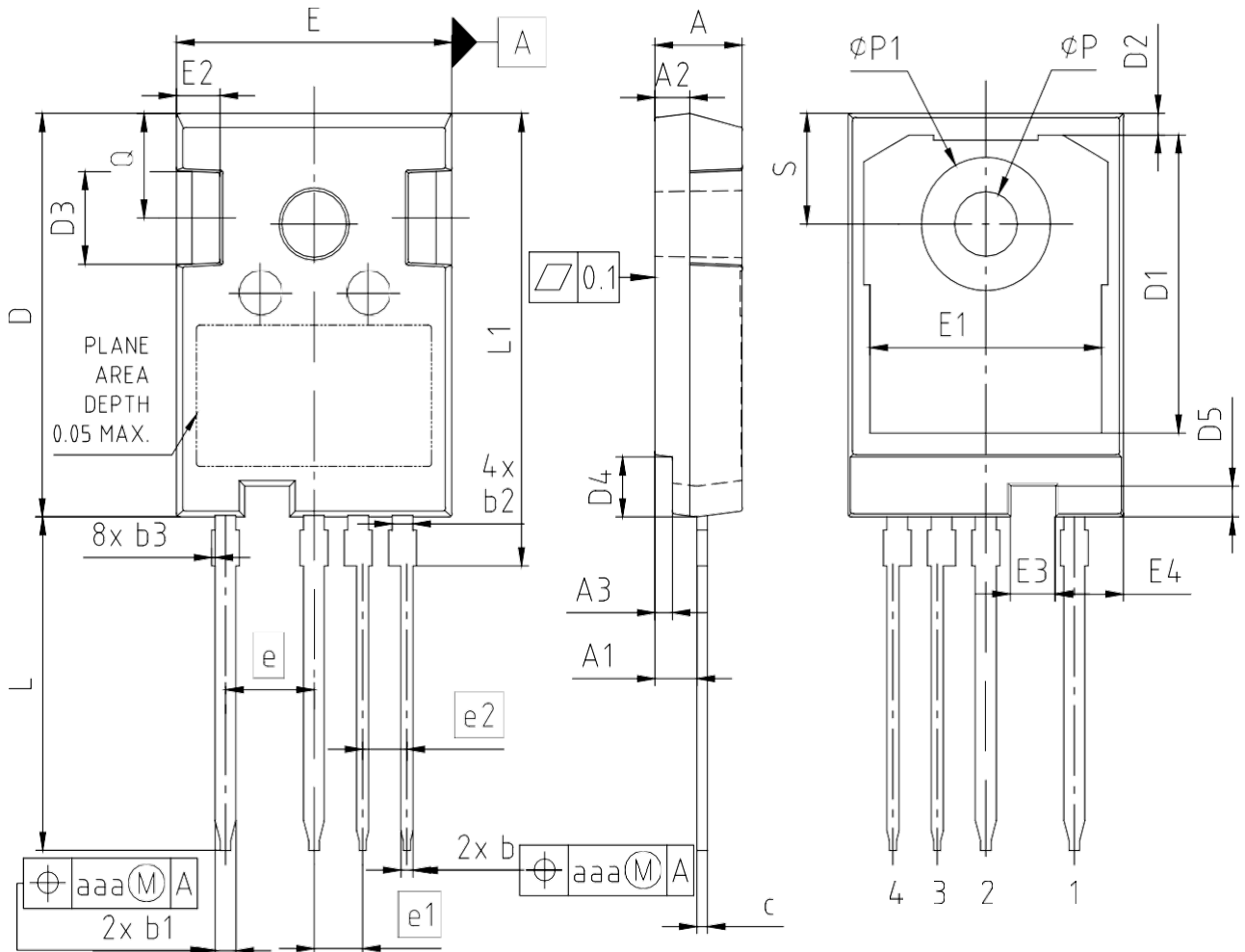

PACKAGE - GROUP NUMBER: **PG-T0247-4-U03**

DIMENSIONS	MILLIMETERS		DIMENSIONS	MILLIMETERS	
	MIN.	MAX.		MIN.	MAX.
A	4.90	5.10	E	15.70	15.90
A1	2.31	2.51	E1	13.10	13.50
A2	1.90	2.10	E2	2.40	2.60
A3	0.90	1.10	E3	2.48	2.68
b	0.66	0.79	E4	3.82	4.02
b1	1.16	1.29	e	5.08	
b2	1.16	1.29	e1	2.79	
b3		0.20	e2	2.54	
c	0.59	0.66	N	4	
D	22.30	22.50	L	18.40	18.70
D1	16.25	16.85	L1	24.97	25.27
D2	1.05	1.35	øP	3.50	3.70
D3	5.00	5.20	øP1		7.40
D4	3.22	3.42	Q	5.60	6.00
D5	1.60	1.80	S	6.00	6.30
			aaa	0.25	

NOTE: DIMENSIONS DO NOT INCLUDE MOLDFLASH; PROTRUSION OR GARE BURRS

图 1

6 测试条件

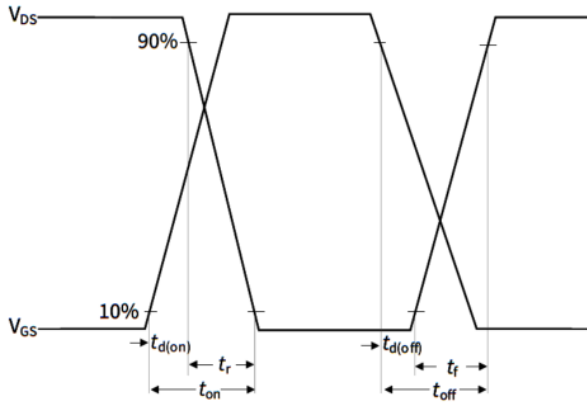

Figure A. Definition of switching times

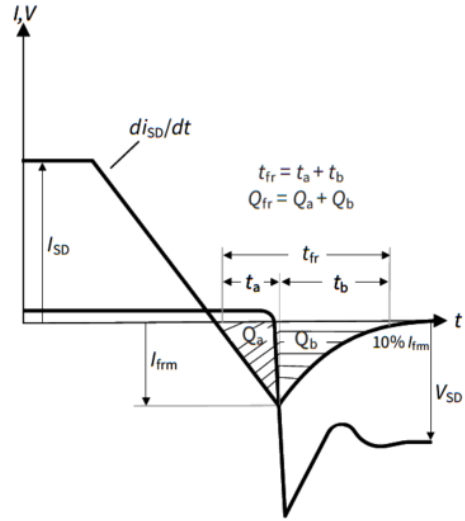

Figure B. Definition of body diode switching characteristics

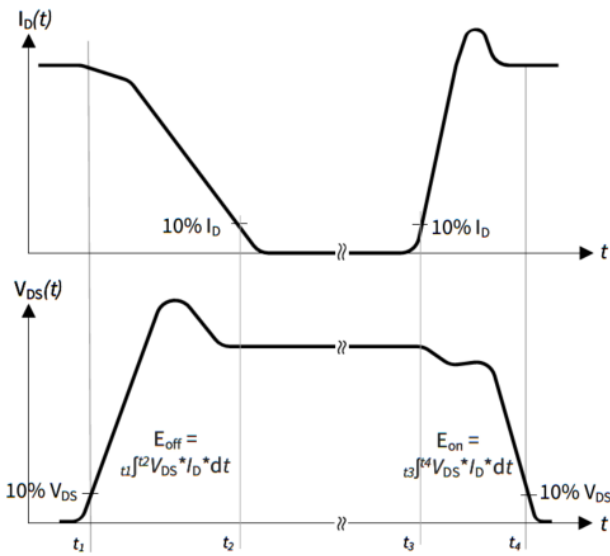

Figure C. Definition of switching losses

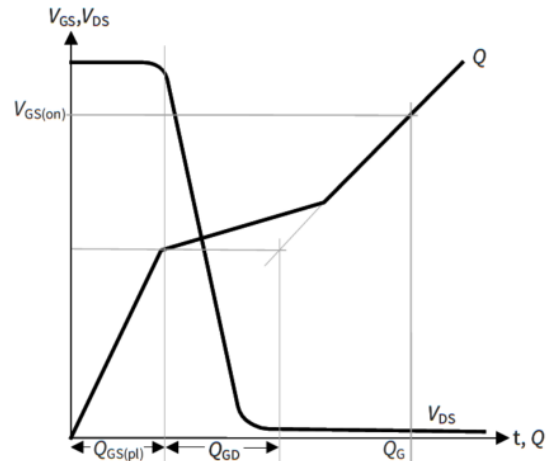

Figure D. Definition of QGD

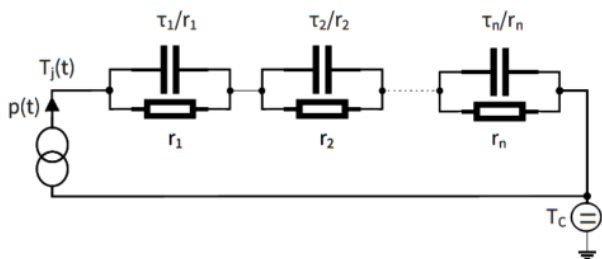

Figure E. Thermal equivalent circuit

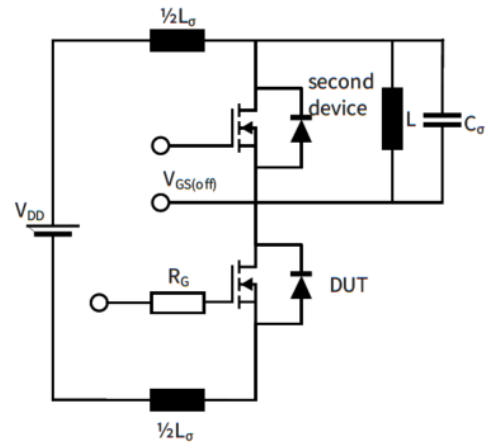

Figure F. Dynamic test circuit
Parasitic inductance L_σ ,
Parasitic capacitor C_σ ,

修订记录

修订记录

Document revision	Date of release	Description of changes
0.10	2022-04-19	Target datasheet
0.20	2023-07-31	Preliminary datasheet
0.30	2023-08-03	Correction of inductance unit (p. 3) Correction of diagram template E(Id)
1.00	2023-11-29	Final datasheet
1.10	2025-08-28	Updated table values: g_{fs} , L_{σ} for switching parameters, $t_{d(on)}$, t_r , $t_{d(off)}$, t_f , E_{on} , E_{off} , E_{tot} , I_{SDC} , Q_{fr} , I_{frm} , condition d_{isd}/dt for Q_{fr} and I_{frm} Added values: creepage distance value on p.1, I_{sm} values for limited t_p Updated graphs: $I_{DS} = f(V_{DS})$, $R_{on}(T_{vj})$, $I_{DS}(V_{GS})$, $I_{SD} = f(v_{SD})$, $E = f(T_{vj})$, $E = f(R_{G,ext})$, $E = f(I_D)$, $t_{sw} = f(R_{G,ext})$, $Z_{th(j-c)} = f(t_p)$ Added graphs: $E_{sw} = f(V_{DS})$, $I_{frm} = f(di/dt)$ No change to the product, new/added values are based on additional assessments



免责声明

请注意，本文件的原文使用英文撰写，为方便客户浏览英飞凌提供了中文译文。该中文译文仅供参考，并不可作为任何论点之依据。

由于翻译过程中可能使用了自动化程序，以及语言翻译和转换过程中的差异，最后的中文译文与最新的英文版本原文含义可能存在不尽相同之处。

因此，我们同时提供该中文译文版本的最新英文原文供您阅读，请参见 <http://www.infineon.com>

英文原文和中文译文版本之间若存有任何歧异，以最新的英文版本为准，并且仅认可英文版本为正式文件。

您如果使用本文件，即表示您同意并理解上述说明。英飞凌不对因翻译过程中可能存在的任何不完整或不准确信息而产生的任何直接或间接损失或损害负责。英飞凌不承担中文译文版本的完整性和准确性责任。如果您不同意上述说明，请不要使用本文件。

Trademarks

All referenced product or service names and trademarks are the property of their respective owners.

重要通知

Infineon Technologies AG 及其关联公司（以下简称“英飞凌”）销售或提供和交付的产品（可能也包括样品，且可能由硬件或软件或两者组成）（以下简称“产品”），应遵守客户与英飞凌签订的框架供应合同或其他书面协议的条款和条件，如无上合同或其他书面协议，则应遵守适用的英飞凌销售条件。只有在英飞凌明确书面同意的情况下，客户的一般条款和条件或对适用的英飞凌销售条件的偏离才对英飞凌具有约束力。

为避免疑义，英飞凌不承担不侵犯第三方权利的所有保证和默示保证，例如对特定用途/目的的适用性或适销性的保证。

英飞凌对与样品、应用或客户对任何产品的具体使用有关的任何信息或本文件中给出的任何示例或典型值概不负责。

本文件中包含的数据仅供具有技术资格和技能的客户代表使用。客户有责任评估产品对预期应用和客户特定用途的适用性，并在预期应用和客户特定用途中验证本文件中包含的所有相关技术数据。客户有责任正确设计、编程和测试预期应用的功能性和安全性，并遵守与其使用相关的法律要求。

除非英飞凌另行明确批准，否则产品不得用于任何因产品故障或使用产品的任何后果可合理预期会导致人身伤害的应用。但是，上述规定并不妨碍客户在英飞凌明确设计和销售的使用领域中使用任何产品，但是客户对应用负有全部责任。

英飞凌明确保留根据适用法律，如《德国版权法》（UrhG）第 44b 条，将其内容用于商业资料和数据探勘（TDM）的权利。

如果产品包含安全功能：

由于任何计算设备都不可能绝对安全，尽管产品采取了安全措施，但英飞凌不保证产品不会被入侵、数据不会被盗或遗失，或不会发生其他漏洞（以下简称“安全漏洞”），英飞凌对任何安全漏洞不承担任何责任。

如果本文件包含或引用软件：

根据美国、德国和世界其他国家的知识产权法律和条约，该软件归英飞凌所有。英飞凌保留所有权利。因此，您只能按照软件附带的软件授权协议的规定使用本软件。

如果没有适用的软件授权协议，英飞凌特此授予您个人的、非排他性的、不可转让的软件知识产权授权（无权转授权）：(a) 对于以源代码形式提供的软件，仅在贵组织内部修改和复制该软件用于英飞凌硬件产品；及 (b) 对于以二进制代码 (binary code) 形式对外向终端用户分发该软件，仅得用于英飞凌硬件产品。禁止对本软件进行任何其他使用、复制、修改、翻译或编译。有关产品、技术、交货条款和条件以及价格的详细信息，请联系离您最近的英飞凌办公室或访问 <https://www.infineon.com>。

版本 2026-03-30

Infineon Technologies AG 出版，
德国 Neubiberg 85579

版权 © 2026 Infineon Technologies AG
及其关联公司。
保留所有权利。

Do you have a question about this
document?

Email:

erratum@infineon.com