

Final datasheet

Short circuit rugged 1200 V TRENCHSTOP™ IGBT 7 technology co-packed with soft and fast recovery diode

Features

- $V_{CE} = 1200\text{ V}$
- $I_C = 15\text{ A}$
- Very low $V_{CEsat} = 1.65\text{ V}$ (typ.) at $I_{Cnom} = 15\text{ A}$, 25°C
- Short circuit robust $t_{sc} = 4\text{ }\mu\text{s}$ at $V_{CE} = 800\text{ V}$, $V_{GE} = 15\text{ V}$
- Smooth switching characteristics
- Wide range of dv/dt controllability
- TO247 package with high creepage distance
- Easy gate drive design
- Co-packed with fast soft recovery emitter controlled 7 diode
- Low EMI signature
- High reliability and operating lifetime

Potential applications

- DC-link discharge switch
- Automotive aux-drives
- Automotive HV heaters

Product validation

- Qualified for automotive applications. Product Validation according to AEC-Q101

Description

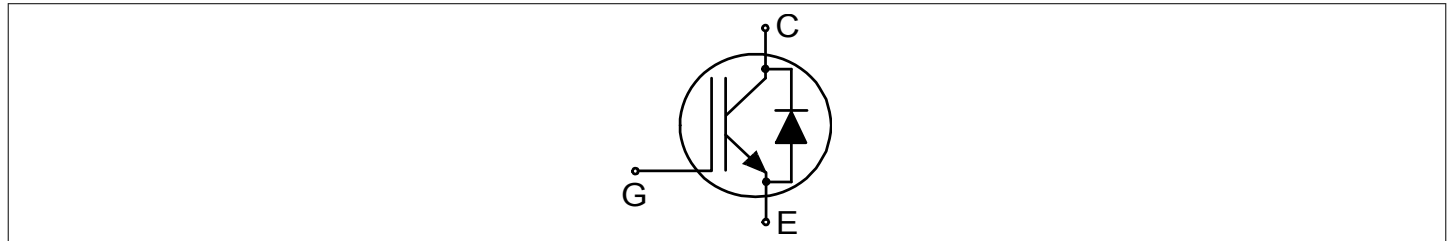

Type	Package	Marking
AIKWH15N120CS7	PG-TO247-3-U04	AW12S7015

Table of contents

	Description	1
	Features	1
	Potential applications	1
	Product validation	1
	Table of contents	2
1	Package	3
2	IGBT	3
3	Diode	5
4	Characteristics diagrams	7
5	Package outlines	16
6	Testing conditions	17
	Revision history	18
	Disclaimer	19

1 Package

Table 1 Characteristic values

Parameter	Symbol	Note or test condition	Values			Unit
			Min.	Typ.	Max.	
Internal emitter inductance	L_E			13		nH
Storage temperature	T_{stg}		-55		150	°C
Soldering temperature	T_{sold}	Wave soldering 1.6 mm (0.063 in.) from case for 10 s			260	°C
Mounting torque	M	M3 screw, Maximum of mounting processes: 3			0.6	Nm
Thermal resistance, junction-ambient	$R_{th(j-a)}$				40	K/W
IGBT thermal resistance, junction-case	$R_{th(j-c)}$			0.65	0.85	K/W
Diode thermal resistance, junction-case	$R_{th(j-c)}$			1.1	1.5	K/W

2 IGBT

Table 2 Maximum rated values

Parameter	Symbol	Note or test condition	Values	Unit	
Collector-emitter voltage	V_{CE}	$T_{vj} \geq 25 \text{ °C}$	1200	V	
DC collector current, limited by T_{vjmax}	I_C		$T_c = 25 \text{ °C}$	48	A
			$T_c = 100 \text{ °C}$	31	
Pulsed collector current, t_p limited by T_{vjmax}	I_{Cpulse}		60	A	
Turn-off safe operating area		$V_{CE} \leq 1200 \text{ V}$, $t_p \leq 1 \text{ }\mu\text{s}$, $T_{vj} \leq 175 \text{ °C}$	60	A	
Gate-emitter voltage	V_{GE}		± 20	V	
Transient gate-emitter voltage	V_{GE}	$D = < 0.01$	± 25	V	
Short-circuit withstand time	t_{SC}	$V_{CC} \leq 800 \text{ V}$, $V_{GE} = -8/15 \text{ V}$, Allowed number of short circuits < 1000 , Time between short circuits $\geq 1.0 \text{ s}$, $T_{vj} = 175 \text{ °C}$	4	μs	
Power dissipation	P_{tot}	$T_{vj} = 175 \text{ °C}$	$T_c = 25 \text{ °C}$	176	W
			$T_c = 100 \text{ °C}$	88	

Table 3 Characteristic values

Parameter	Symbol	Note or test condition		Values			Unit
				Min.	Typ.	Max.	
Collector-emitter saturation voltage	V_{CEsat}	$I_C = 15\text{ A}, V_{GE} = 15\text{ V}$	$T_{vj} = 25\text{ °C}$		1.65	2	V
			$T_{vj} = 175\text{ °C}$		2		
Gate-emitter threshold voltage	V_{GETh}	$I_C = 0.29\text{ mA}, V_{CE} = V_{GE}$		5.15	5.7	6.45	V
Zero gate-voltage collector current	I_{CES}	$V_{CE} = 1200\text{ V}, V_{GE} = 0\text{ V}$	$T_{vj} = 25\text{ °C}$			40	μA
			$T_{vj} = 175\text{ °C}$		800		
Gate-emitter leakage current	I_{GES}	$V_{CE} = 0\text{ V}, V_{GE} = 20\text{ V}$				100	nA
Transconductance	g_{fs}	$I_C = 15\text{ A}, V_{CE} = 20\text{ V}, T_{vj} = 175\text{ °C}$			6.9		S
Short-circuit collector current	I_{SC}	$V_{CC} \leq 800\text{ V}, V_{GE} = 15\text{ V}, t_{SC} \leq 4\text{ }\mu\text{s},$ Allowed number of short circuits < 1000, Time between short circuits $\geq 1.0\text{ s}$	$T_{vj} = 25\text{ °C}$		95		A
			$T_{vj} = 175\text{ °C}$		75		
Internal gate resistance	$R_{G,int}$	$f = 100\text{ kHz}$			4.6		Ω
Input capacitance	C_{ies}	$V_{CE} = 25\text{ V}, V_{GE} = 0\text{ V}, f = 100\text{ kHz}$			2.2		nF
Output capacitance	C_{oes}	$V_{CE} = 25\text{ V}, V_{GE} = 0\text{ V}, f = 100\text{ kHz}$			55		pF
Reverse transfer capacitance	C_{res}	$V_{CE} = 25\text{ V}, V_{GE} = 0\text{ V}, f = 100\text{ kHz}$			10		pF
Gate charge	Q_G	$V_{CC} = 960\text{ V}, I_C = 15\text{ A}, V_{GE} = -8/15\text{ V}$			147		nC
Turn-on delay time	$t_{d(on)}$	$V_{CC} = 800\text{ V}, V_{GE} = -8/15\text{ V}, R_G = 9.8\text{ }\Omega$	$T_{vj} = 25\text{ °C}, I_C = 15\text{ A}$		15		ns
			$T_{vj} = 175\text{ °C}, I_C = 15\text{ A}$		16		
Rise time (inductive load)	t_r	$V_{CC} = 800\text{ V}, V_{GE} = -8/15\text{ V}, R_G = 9.8\text{ }\Omega$	$T_{vj} = 25\text{ °C}, I_C = 15\text{ A}$		11		ns
			$T_{vj} = 175\text{ °C}, I_C = 15\text{ A}$		13		
Turn-off delay time	$t_{d(off)}$	$V_{CC} = 800\text{ V}, V_{GE} = -8/15\text{ V}, R_G = 9.8\text{ }\Omega$	$T_{vj} = 25\text{ °C}, I_C = 15\text{ A}$		125		ns
			$T_{vj} = 175\text{ °C}, I_C = 15\text{ A}$		235		
Fall time (inductive load)	t_f	$V_{CC} = 800\text{ V}, V_{GE} = -8/15\text{ V}, R_G = 9.8\text{ }\Omega$	$T_{vj} = 25\text{ °C}, I_C = 15\text{ A}$		118		ns
			$T_{vj} = 175\text{ °C}, I_C = 15\text{ A}$		187		

(table continues...)

Table 3 (continued) Characteristic values

Parameter	Symbol	Note or test condition	Values			Unit	
			Min.	Typ.	Max.		
Turn-on energy ¹⁾	E_{on}	$V_{CC} = 800\text{ V}, V_{GE} = -8/15\text{ V}, R_G = 9.8\ \Omega$	$T_{vj} = 25\text{ °C}, I_C = 15\text{ A}$		0.98		mJ
			$T_{vj} = 175\text{ °C}, I_C = 15\text{ A}$		1.8		
Turn-off energy	E_{off}	$V_{CC} = 800\text{ V}, V_{GE} = -8/15\text{ V}, R_G = 9.8\ \Omega$	$T_{vj} = 25\text{ °C}, I_C = 15\text{ A}$		0.99		mJ
			$T_{vj} = 175\text{ °C}, I_C = 15\text{ A}$		2.05		
Total switching energy	E_{ts}	$V_{CC} = 800\text{ V}, V_{GE} = -8/15\text{ V}, R_G = 9.8\ \Omega$	$T_{vj} = 25\text{ °C}, I_C = 15\text{ A}$		1.97		mJ
			$T_{vj} = 175\text{ °C}, I_C = 15\text{ A}$		3.84		
Operating junction temperature	T_{vj}		-40		175	°C	

1) Includes IGBT losses caused by reverse recovery current

3 Diode

Table 4 Maximum rated values

Parameter	Symbol	Note or test condition	Values	Unit	
Repetitive peak reverse voltage	V_{RRM}	$T_{vj} \geq 25\text{ °C}$	1200	V	
Diode forward current, limited by T_{vjmax}	I_F		$T_c = 25\text{ °C}$	40	A
			$T_c = 100\text{ °C}$	25	
Diode pulsed current, t_p limited by T_{vjmax}	I_{Fpulse}		60	A	
Power dissipation	P_{tot}	$T_{vj} = 175\text{ °C}$	$T_c = 25\text{ °C}$	100	W
			$T_c = 100\text{ °C}$	50	

Table 5 Characteristic values

Parameter	Symbol	Note or test condition	Values			Unit	
			Min.	Typ.	Max.		
Diode forward voltage	V_F	$I_F = 15\text{ A}$	$T_{vj} = 25\text{ °C}$		1.65	2.15	V
			$T_{vj} = 175\text{ °C}$		1.6		

(table continues...)

Table 5 (continued) Characteristic values

Parameter	Symbol	Note or test condition	Values			Unit
			Min.	Typ.	Max.	
Diode reverse recovery charge	Q_{rr}		$T_{vj} = 25\text{ °C},$ $I_F = 15\text{ A}$		1.08	μC
			$T_{vj} = 175\text{ °C},$ $I_F = 15\text{ A}$		2.75	
Diode peak reverse recovery current	I_{rrm}		$T_{vj} = 25\text{ °C},$ $I_F = 15\text{ A}$		15.9	A
			$T_{vj} = 175\text{ °C},$ $I_F = 15\text{ A}$		21.7	
Diode reverse recovery energy	E_{rec}		$T_{vj} = 25\text{ °C},$ $I_F = 15\text{ A}$		0.46	mJ
			$T_{vj} = 175\text{ °C},$ $I_F = 15\text{ A}$		1.31	
Operating junction temperature	T_{vj}		-40		175	$^{\circ}\text{C}$

Note: For optimum lifetime and reliability, Infineon recommends operating conditions that do not exceed 80% of the maximum ratings stated in this datasheet.

Electrical Characteristic at $T_{vj} = 25\text{ °C}$, unless otherwise specified.

Dynamic test circuit, parasitic inductance $L_{\sigma} = 30\text{ nH}$, $C_{\sigma} = 8\text{ pF}$.

4 Characteristics diagrams

Power dissipation as a function of case temperature

$P_{tot} = f(T_c)$
 $T_{vj} \leq 175\text{ °C}$

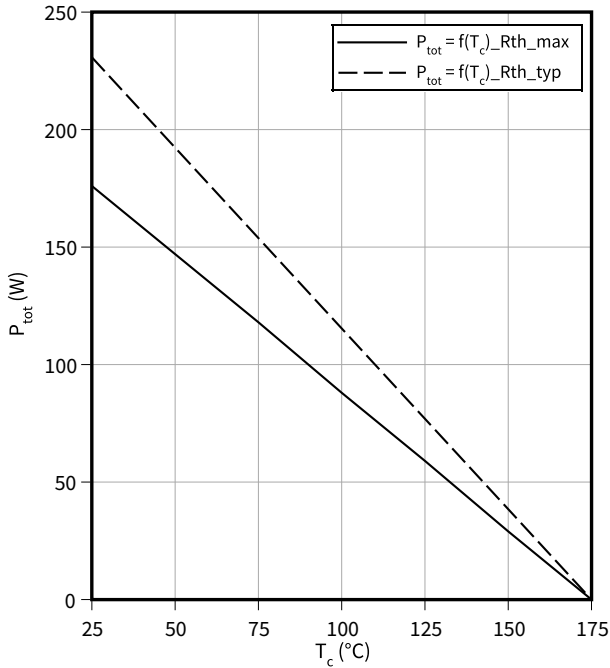

Collector current as a function of case temperature

$I_C = f(T_c)$
 $T_{vj} \leq 175\text{ °C}, V_{GE} \geq 15\text{ V}$

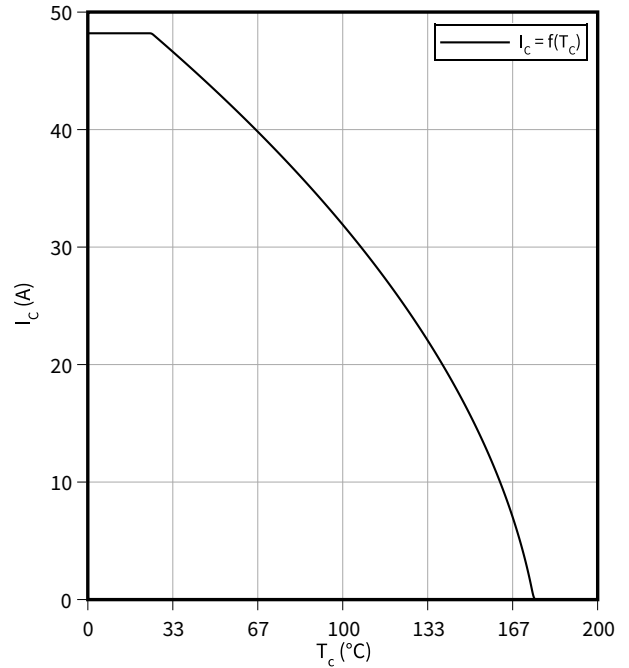

Typical output characteristic

$I_C = f(V_{CE})$
 $T_{vj} = 25\text{ °C}$

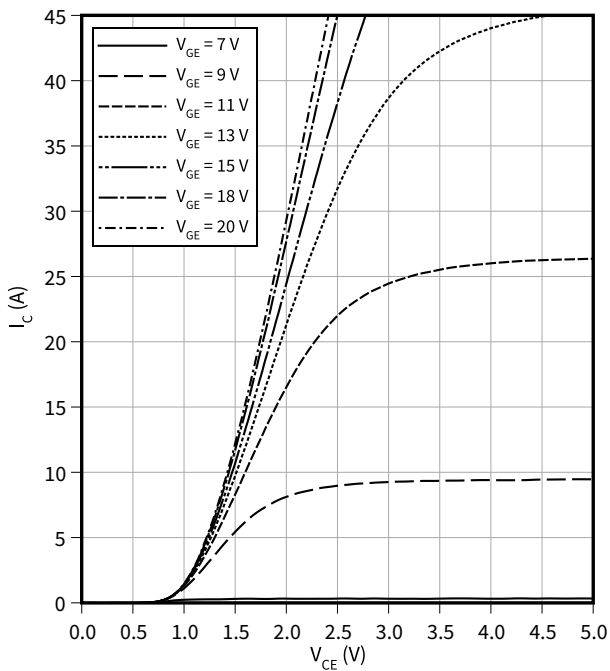

Typical output characteristic

$I_C = f(V_{CE})$
 $T_{vj} = 175\text{ °C}$

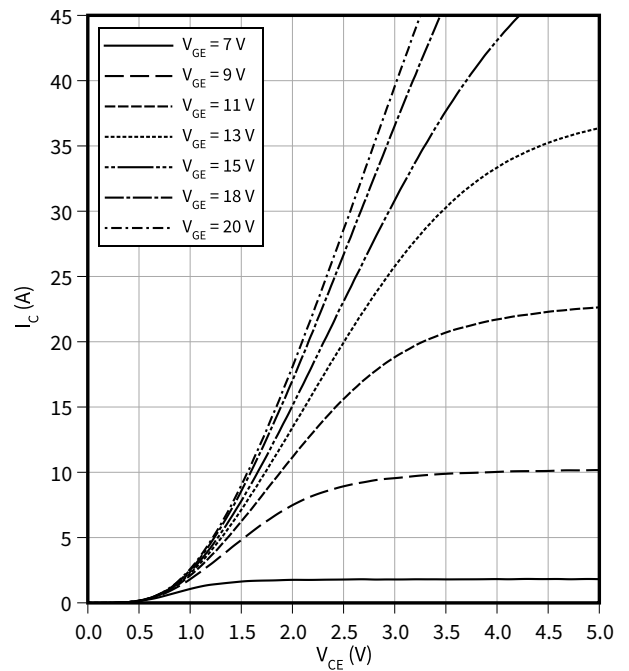

4 Characteristics diagrams

Typical transfer characteristic

$I_C = f(V_{GE})$

$V_{CE} = 20\text{ V}$

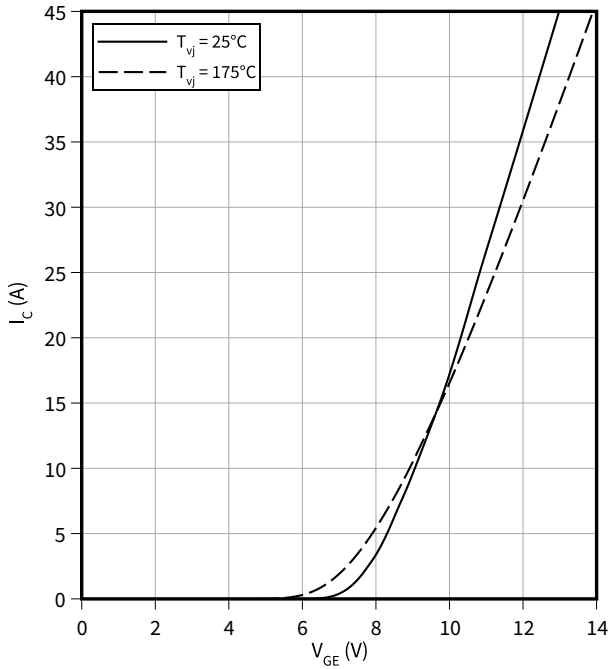

Typical collector-emitter saturation voltage as a function of junction temperature

$V_{CEsat} = f(T_{vj})$

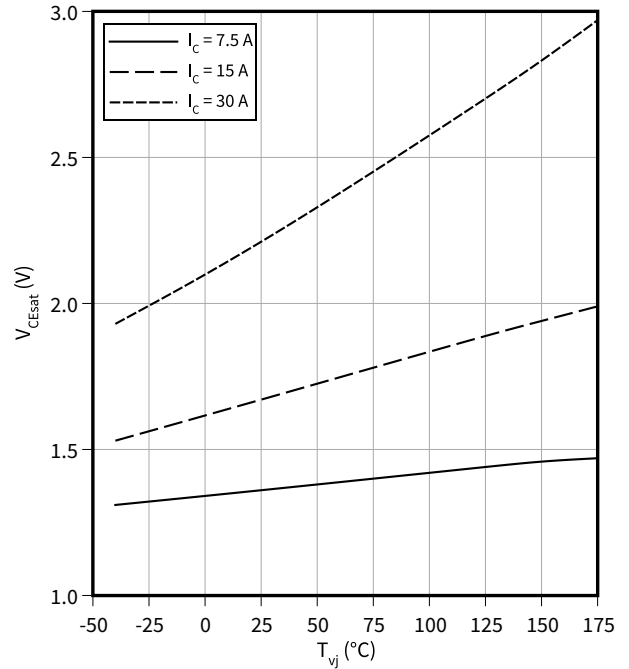

Gate-emitter threshold voltage as a function of junction temperature

$V_{GEth} = f(T_{vj})$

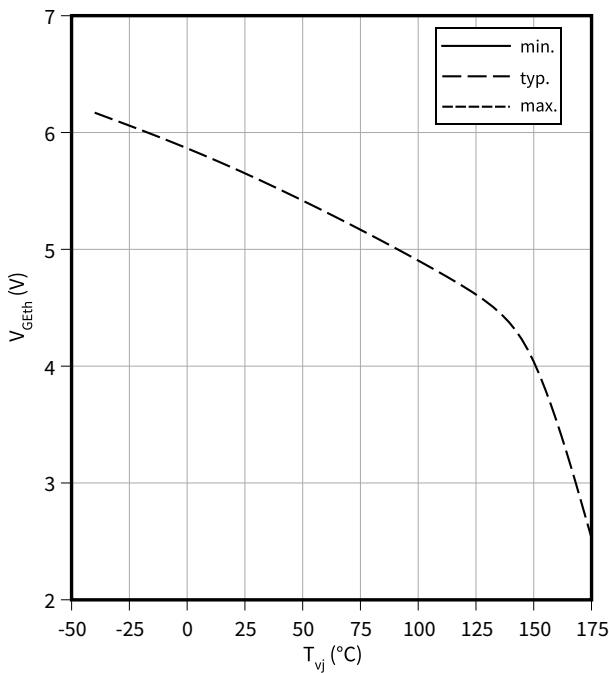

Typical switching times as a function of collector current

$t = f(I_C)$

$V_{CC} = 800\text{ V}, T_{vj} = 175^\circ\text{C}, R_G = 9.8\ \Omega$

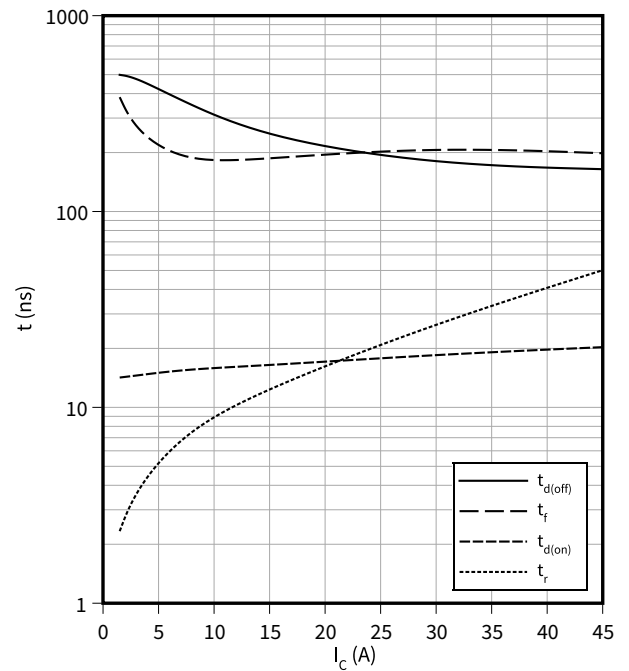

4 Characteristics diagrams

Typical switching times as a function of collector current

$t = f(I_C)$

$V_{CC} = 800 \text{ V}, T_{vj} = 25 \text{ }^\circ\text{C}, R_G = 9.8 \text{ } \Omega$

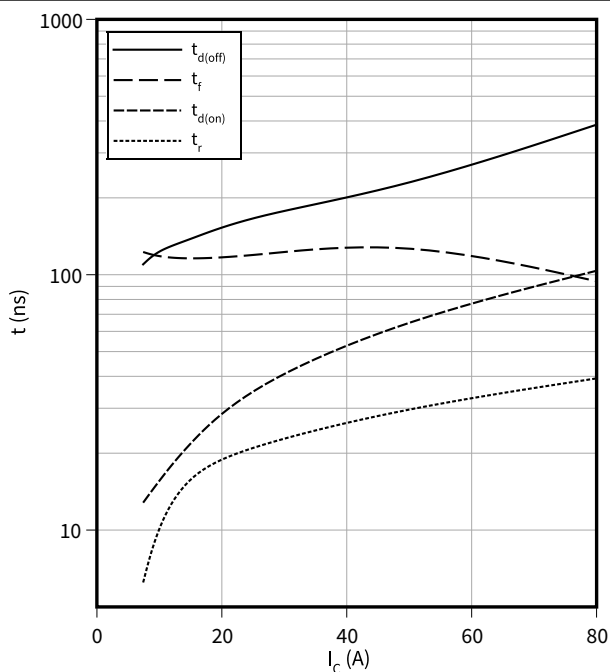

Typical switching times as a function of gate resistor

$t = f(R_G)$

$I_C = 15 \text{ A}, V_{CC} = 800 \text{ V}, T_{vj} = 175 \text{ }^\circ\text{C}$

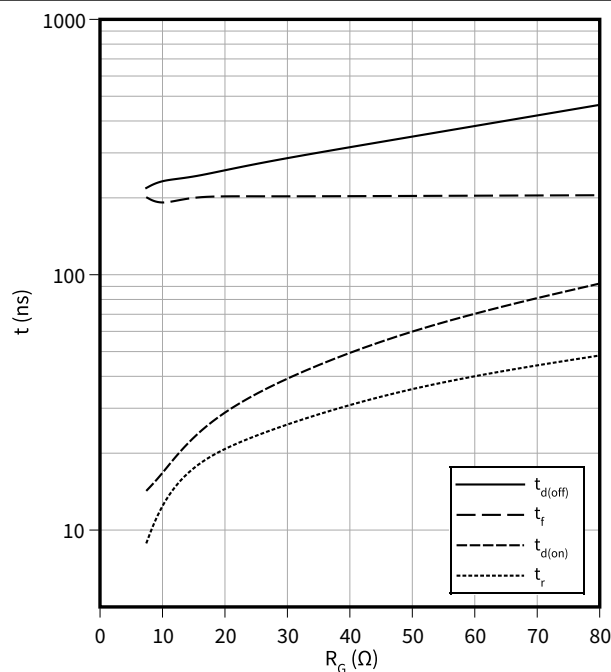

Typical switching times as a function of gate resistor

$t = f(R_G)$

$I_C = 15 \text{ A}, V_{CC} = 800 \text{ V}, T_{vj} = 25 \text{ }^\circ\text{C}$

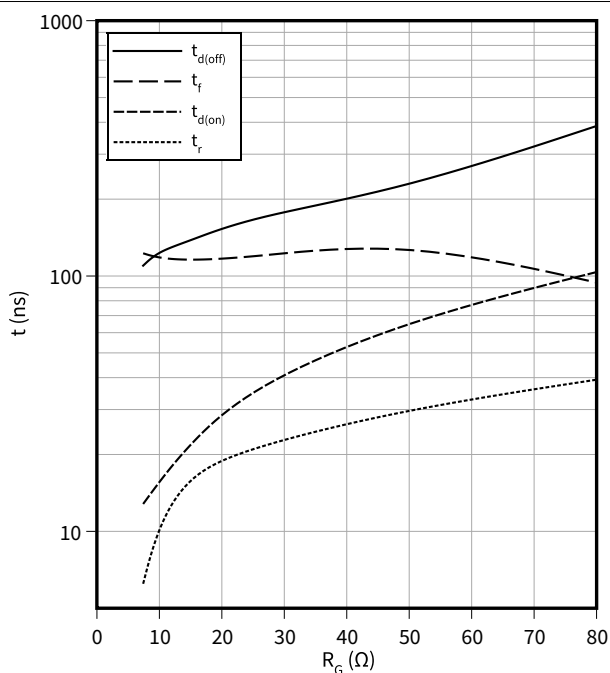

Typical switching times as a function of junction temperature

$t = f(T_{vj})$

$I_C = 15 \text{ A}, V_{CC} = 800 \text{ V}, R_G = 9.8 \text{ } \Omega$

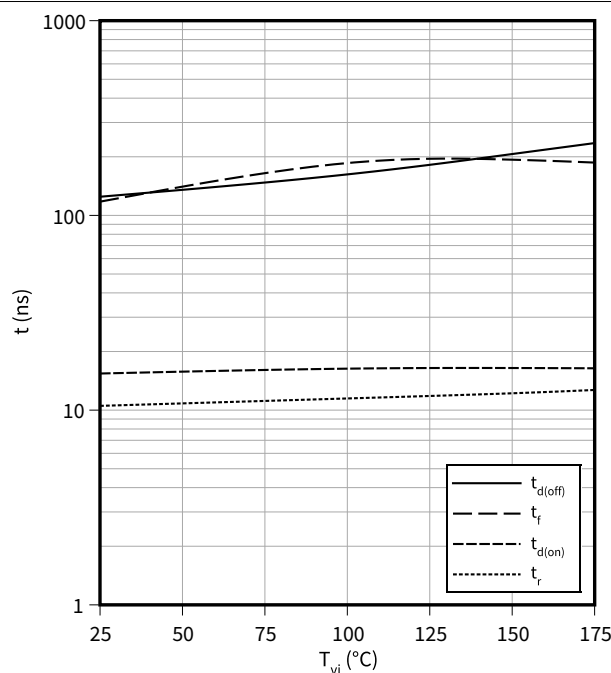

4 Characteristics diagrams

Typical switching energy losses as a function of collector current

$E = f(I_C)$

$V_{CC} = 800\text{ V}$, $T_{vj} = 175\text{ °C}$, $R_G = 9.8\ \Omega$

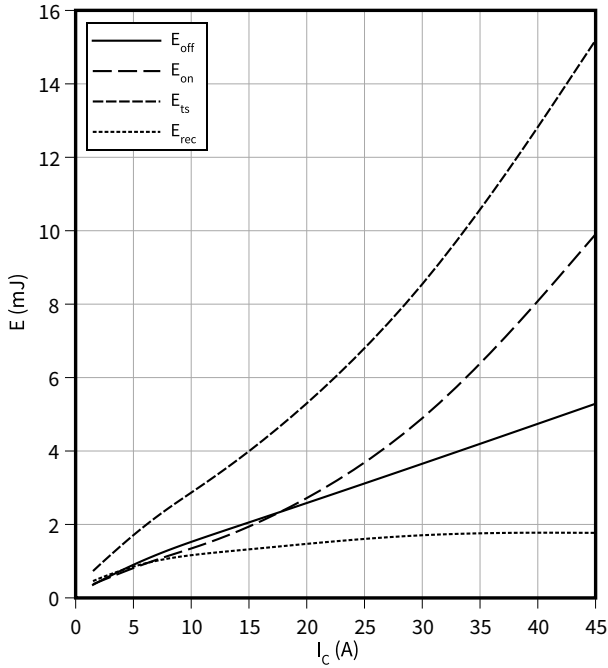

Typical switching energy losses as a function of collector current

$E = f(I_C)$

$V_{CC} = 800\text{ V}$, $T_{vj} = 25\text{ °C}$, $R_G = 9.8\ \Omega$

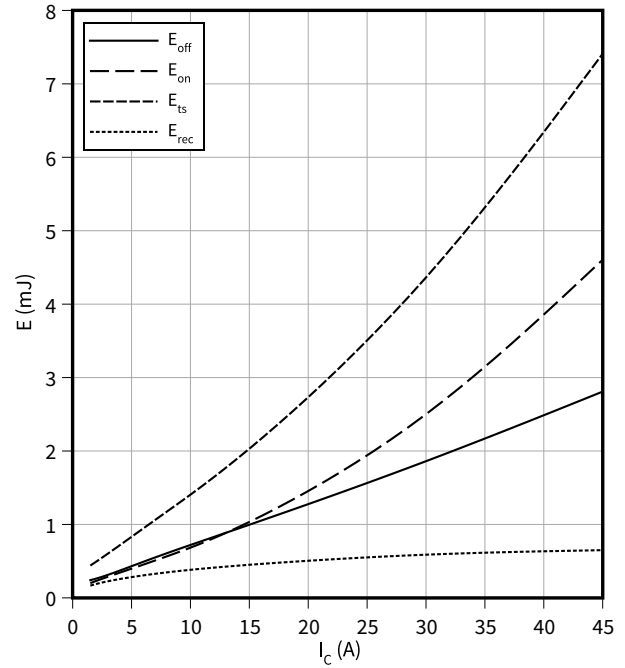

Typical switching energy losses as a function of gate resistor

$E = f(R_G)$

$I_C = 15\text{ A}$, $V_{CC} = 800\text{ V}$, $T_{vj} = 175\text{ °C}$

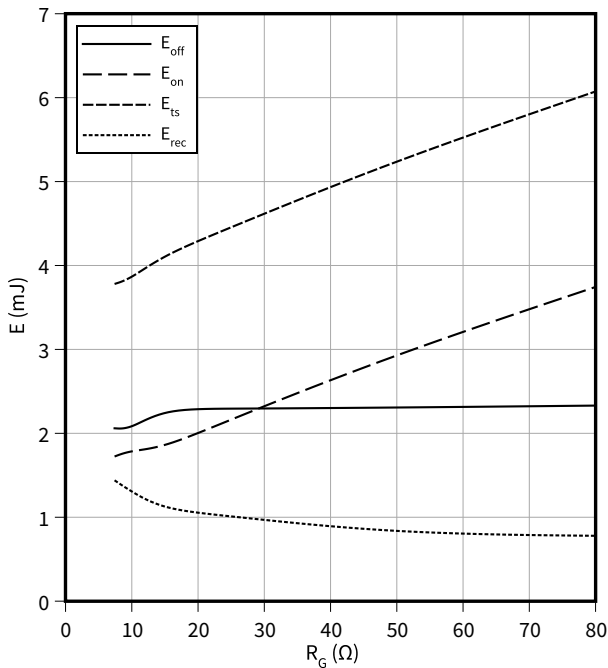

Typical switching energy losses as a function of gate resistor

$E = f(R_G)$

$I_C = 15\text{ A}$, $V_{CC} = 800\text{ V}$, $T_{vj} = 25\text{ °C}$

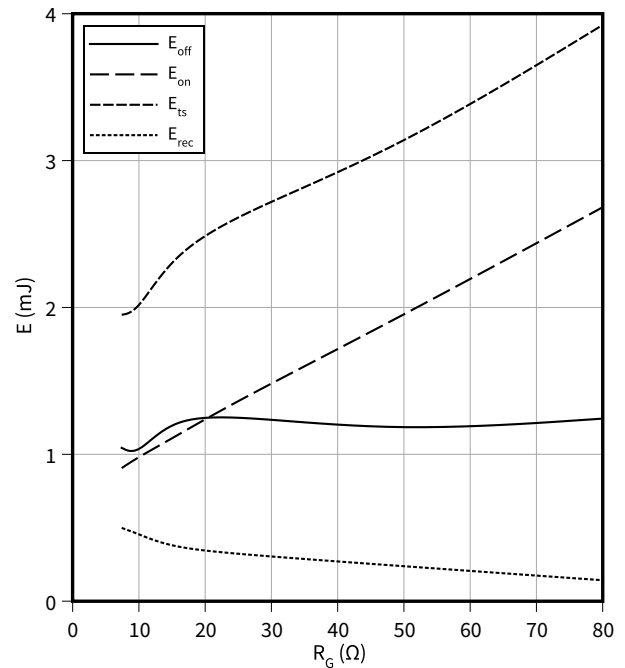

4 Characteristics diagrams

Typical switching energy losses as a function of junction temperature

$E = f(T_{vj})$

$I_C = 15\text{ A}, V_{CC} = 800\text{ V}, R_G = 9.8\ \Omega$

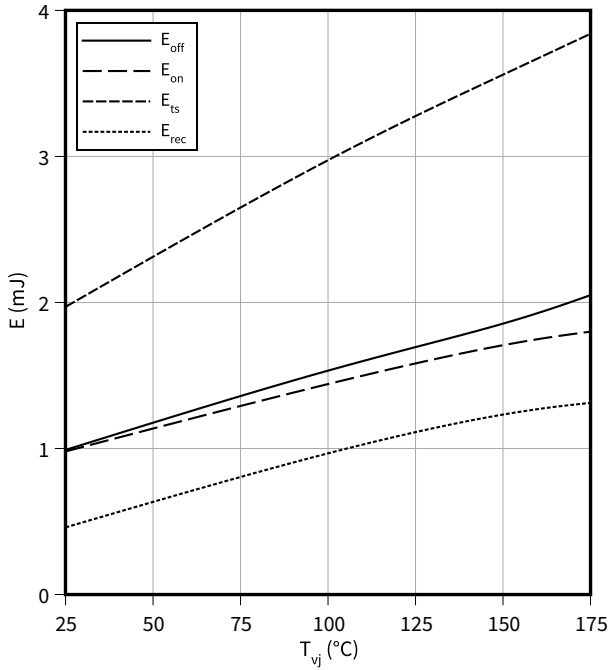

Typical switching energy losses as a function of collector emitter voltage

$E = f(V_{CE})$

$I_C = 15\text{ A}, T_{vj} = 25\text{ °C}, R_G = 9.8\ \Omega$

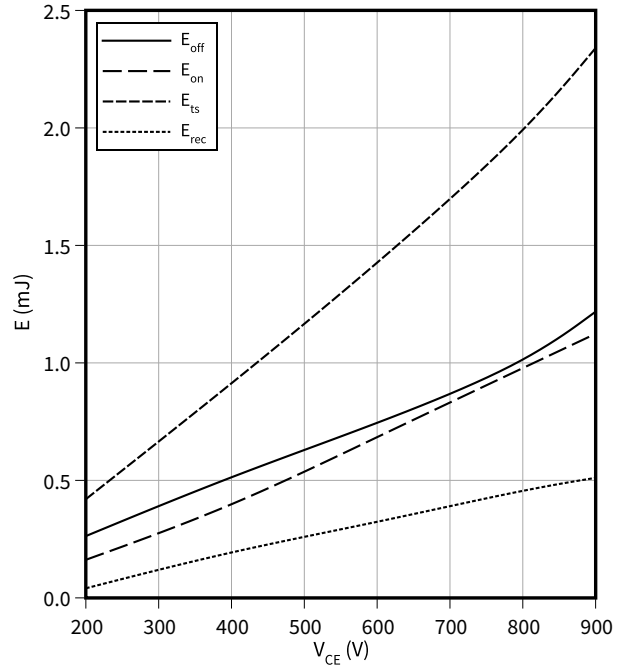

Typical switching energy losses as a function of collector emitter voltage

$E = f(V_{CE})$

$I_C = 15\text{ A}, T_{vj} = 175\text{ °C}, R_G = 9.8\ \Omega$

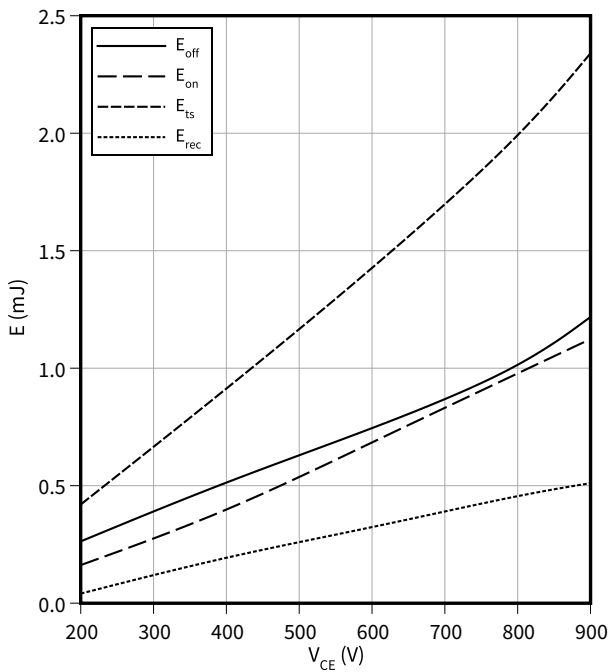

Typical gate charge

$V_{GE} = f(Q_G)$

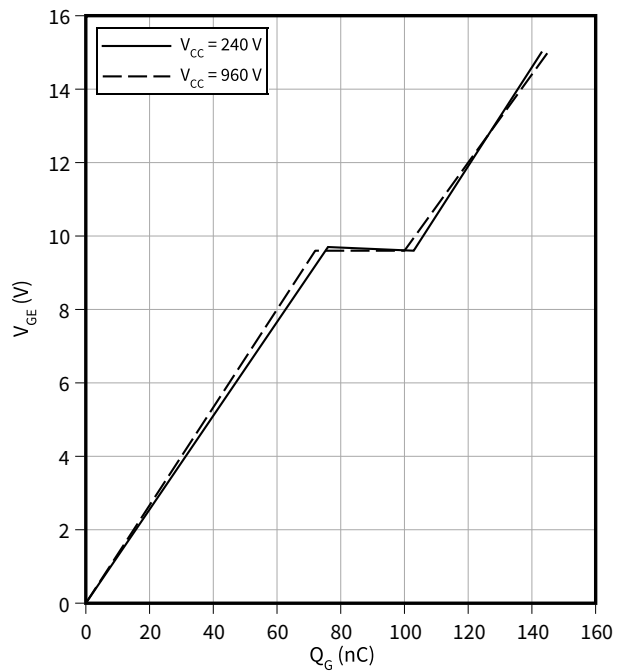

4 Characteristics diagrams

Typical capacitance as a function of collector-emitter voltage

$C = f(V_{CE})$

$f = 100 \text{ kHz}, V_{GE} = 0 \text{ V}$

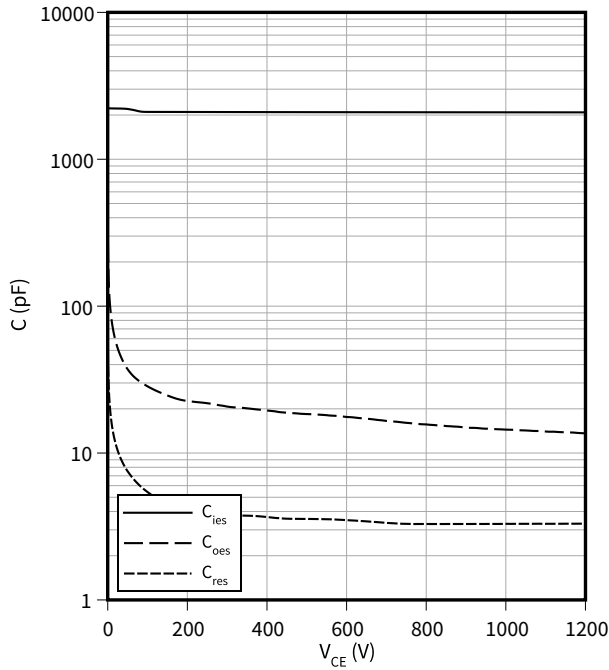

Typical short circuit collector current as a function of gate-emitter voltage

$I_{C(SC)} = f(V_{GE})$

$T_{vj} = 175 \text{ °C}, V_{CC} = 800 \text{ V}$

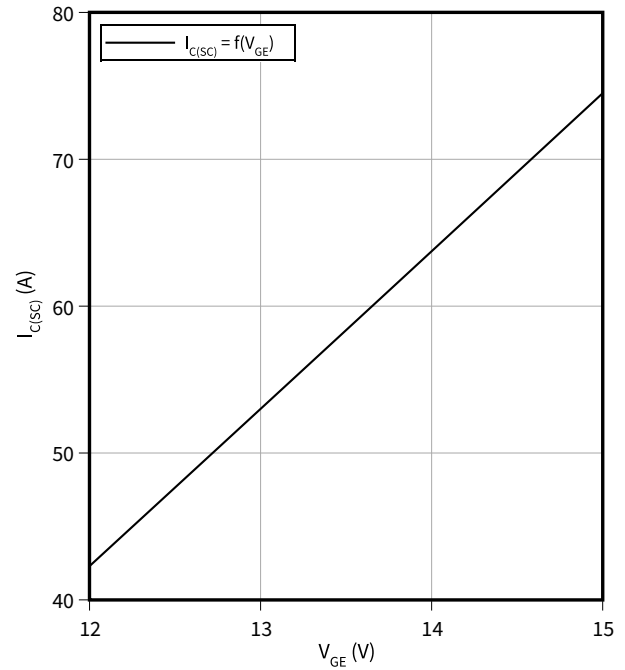

Short circuit withstand time as a function of gate-emitter voltage

$t_{SC} = f(V_{GE})$

$T_{vj} = 175 \text{ °C}, V_{CC} = 800 \text{ V}$

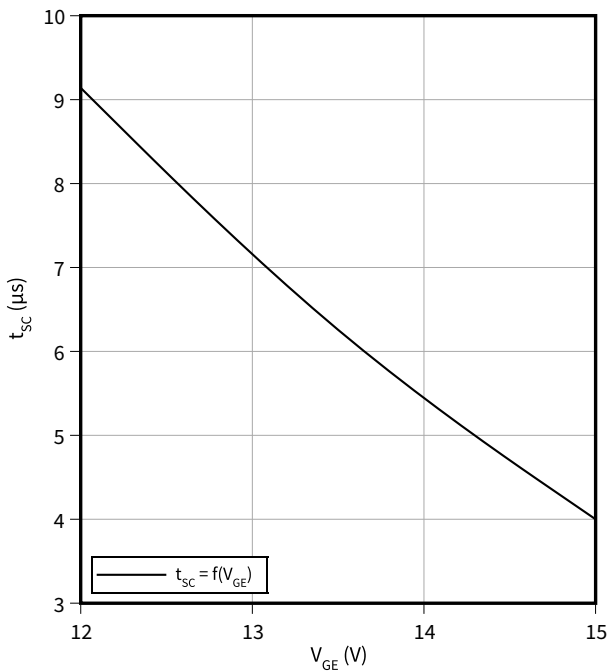

IGBT typical transient thermal impedance as a function of pulse width

$Z_{th(j-c)} = f(t_p)$

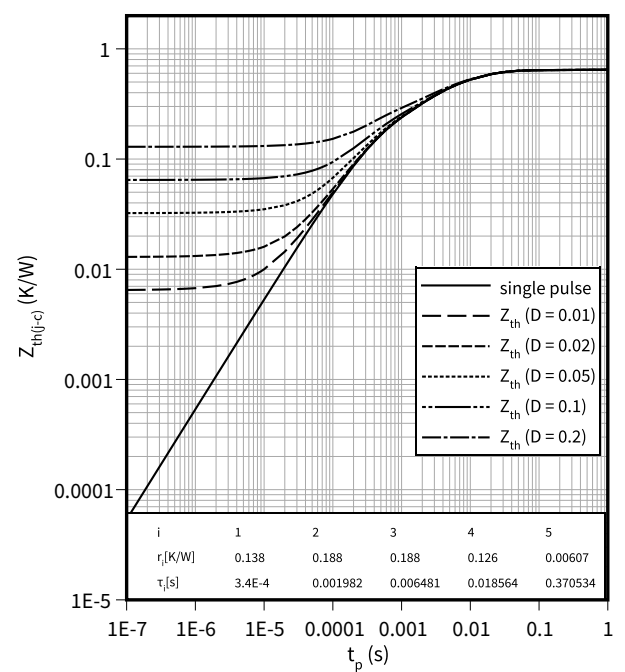

4 Characteristics diagrams

Diode typical transient thermal impedance as a function of pulse width

$Z_{th(j-c)} = f(t_p)$
 $D = t_p/T$

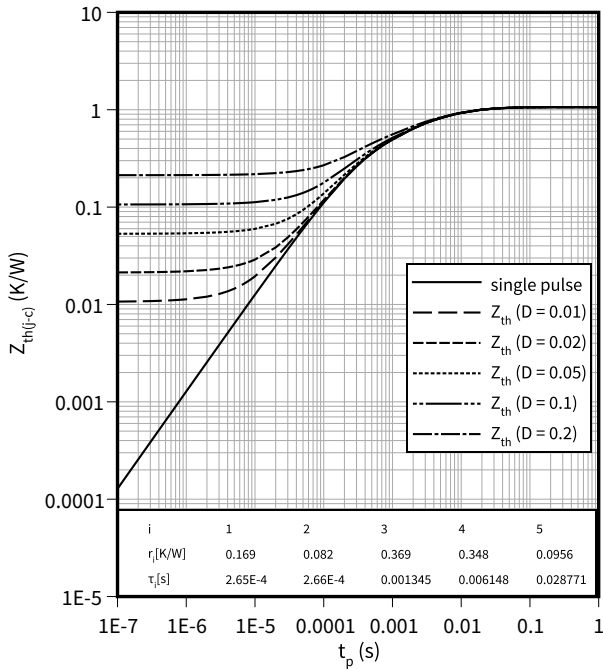

Typical diode forward current as a function of forward voltage

$I_F = f(V_F)$

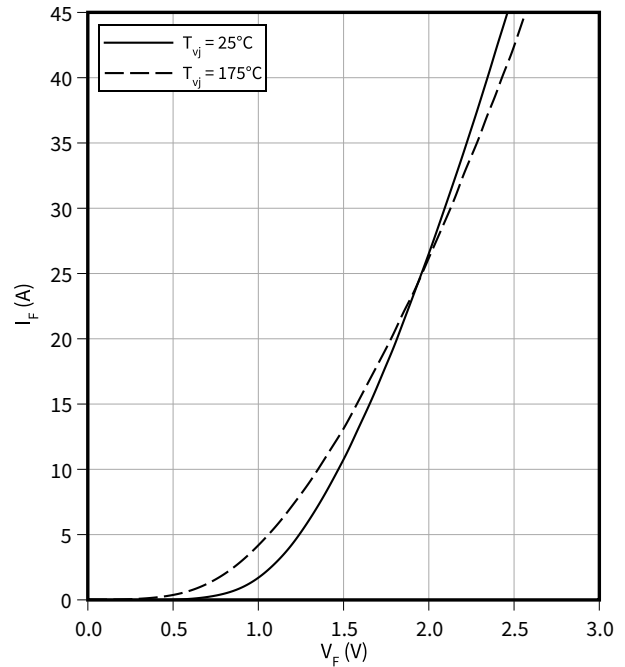

Typical diode forward voltage as a function of junction temperature

$V_F = f(T_{vj})$

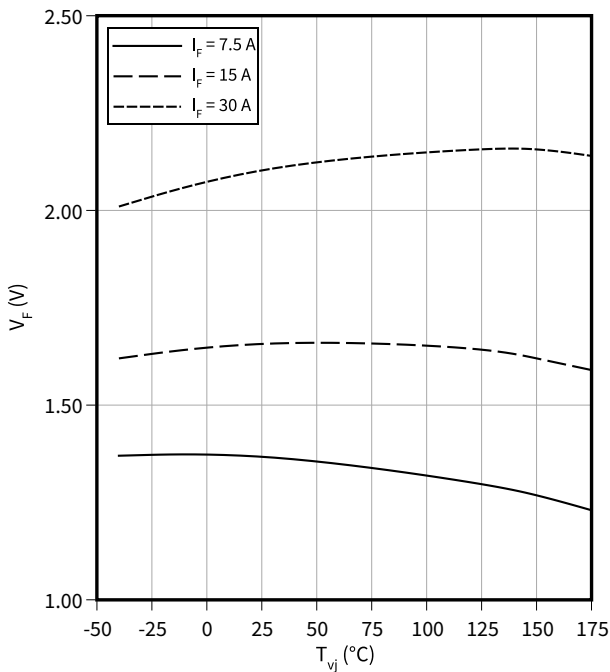

Typical reverse recovery time as a function of diode current slope

$t_{rr} = f(di_F/dt)$
 $V_R = 800 \text{ V}, I_F = 15 \text{ A}$

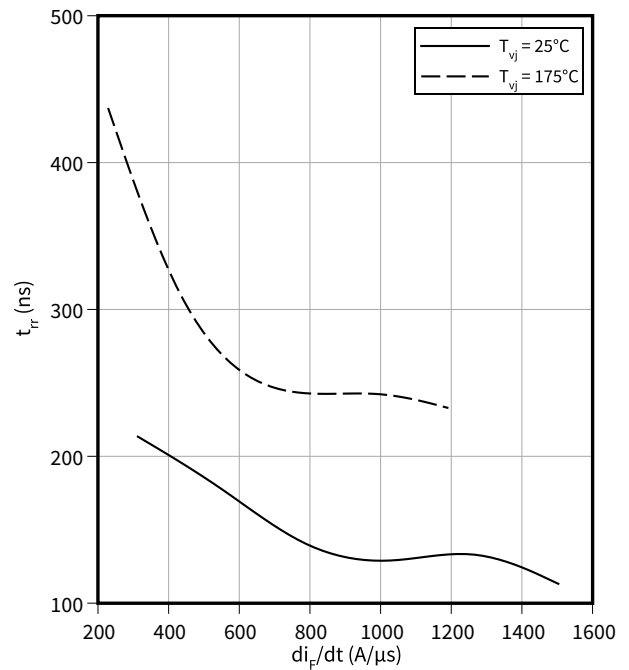

4 Characteristics diagrams

Typical reverse recovery charge as a function of diode current slope

$Q_{rr} = f(di_F/dt)$

$V_R = 800\text{ V}, I_F = 15\text{ A}$

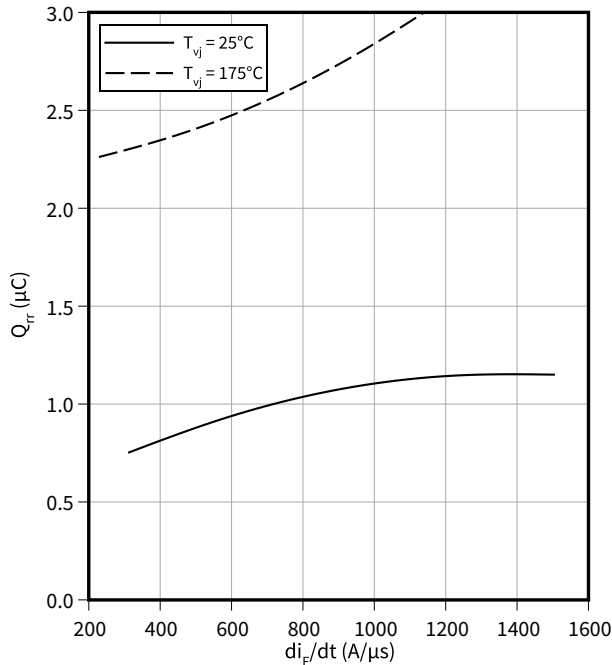

Typical reverse recovery current as a function of diode current slope

$I_{rrm} = f(di_F/dt)$

$V_R = 800\text{ V}, I_F = 15\text{ A}$

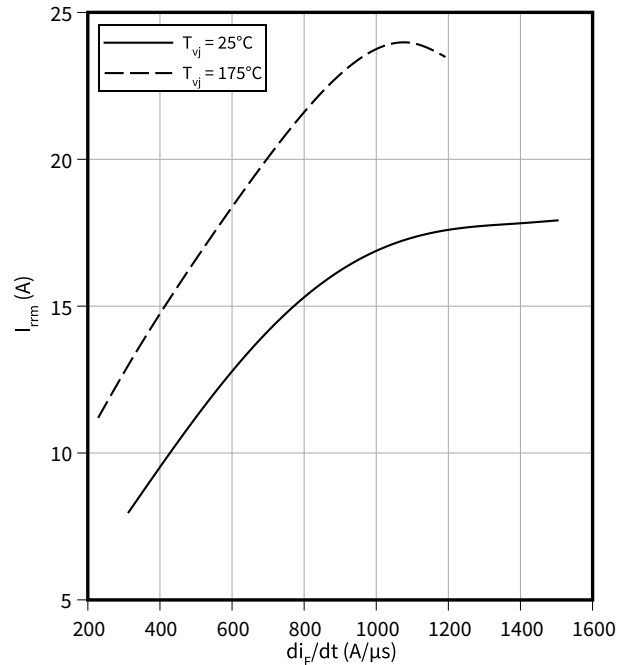

Typical diode peak rate of fall of reverse recovery current as a function of diode current slope

$di_{rr}/dt = f(di_F/dt)$

$V_R = 800\text{ V}, I_F = 15\text{ A}$

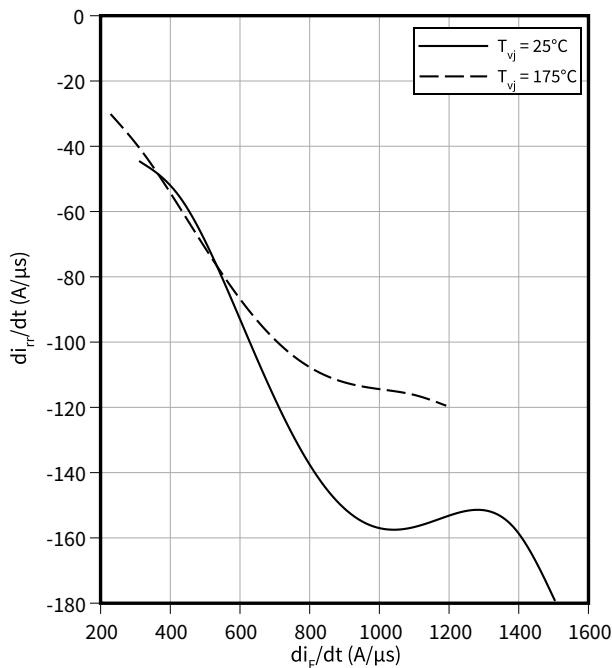

Typical reverse energy losses as a function of diode current slope

$E_{rec} = f(di_F/dt)$

$V_R = 800\text{ V}, I_F = 15\text{ A}$

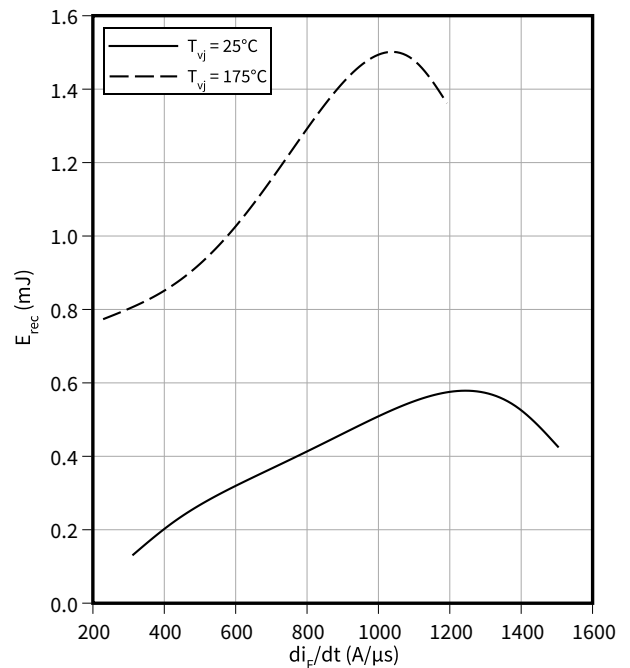

Typical diode current slope as a function of gate resistor

$$di_F/dt = f(R_G)$$

$V_R = 800 \text{ V}$, $I_F = 15 \text{ A}$

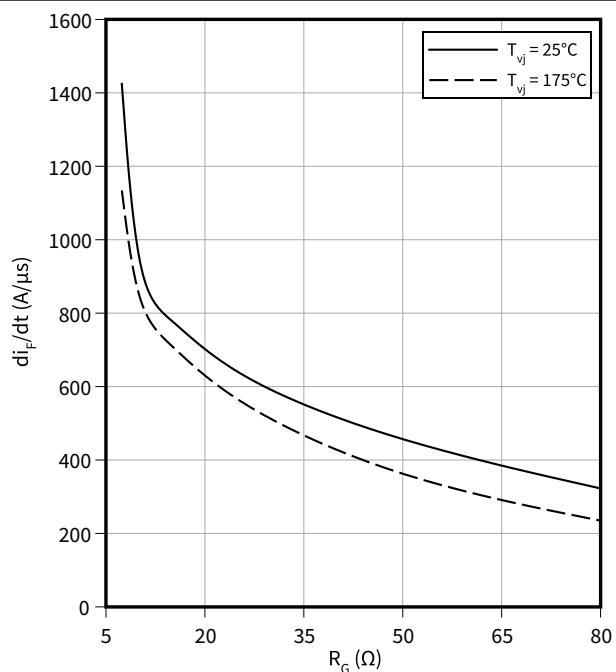

5 Package outlines

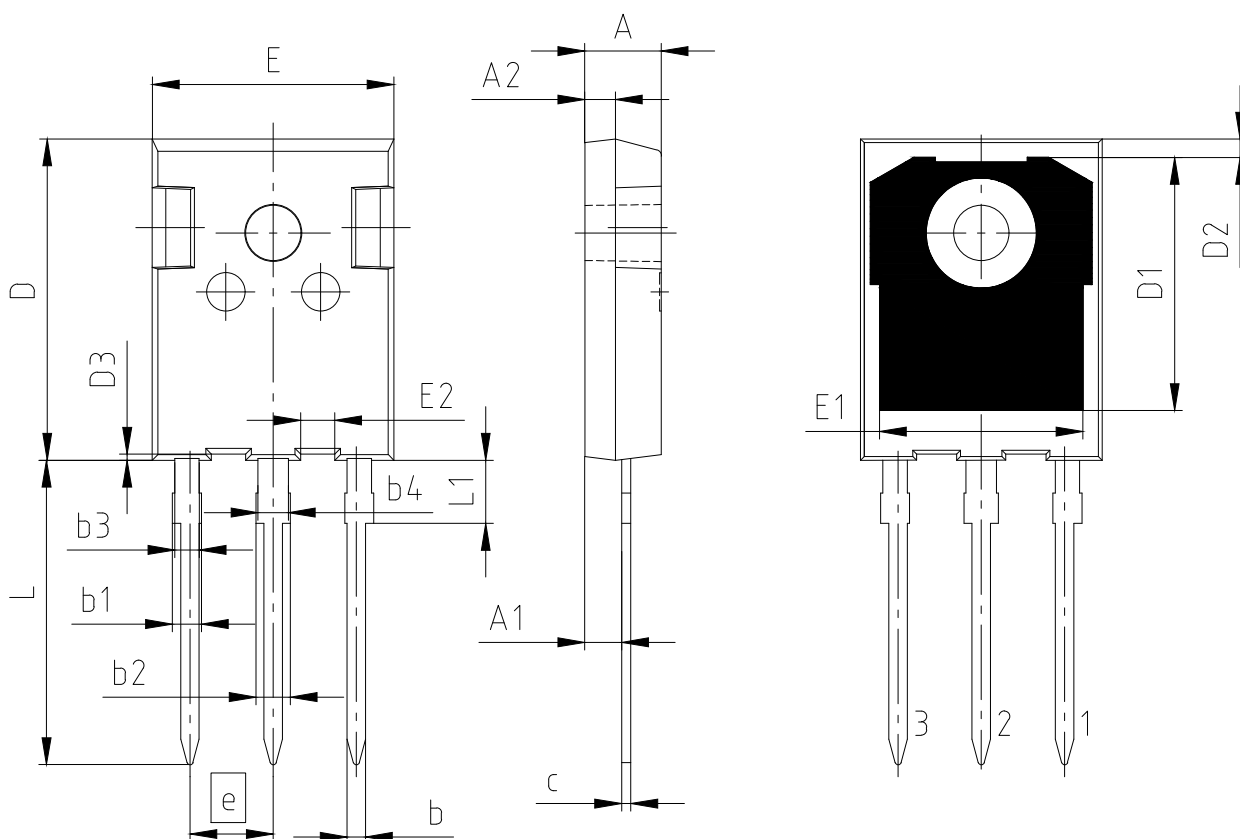

PACKAGE - GROUP NUMBER: PG-TO247-3-U04		
DIMENSIONS	MILLIMETERS	
	MIN.	MAX.
A	4.90	5.10
A1	2.31	2.51
A2	1.90	2.10
b	1.16	1.26
b1		1.90
b2		2.30
b3	1.55	1.65
b4	1.96	2.06
c	0.59	0.66
D	20.90	21.10
D1	16.25	16.85
D2	1.05	1.35
D3	0.55	0.65
E	15.70	15.90
E1	13.10	13.50
E2	2.14	2.34
e	5.44	
N	3	
L	19.80	20.10
L1	3.95	4.30

Figure 1

6 Testing conditions

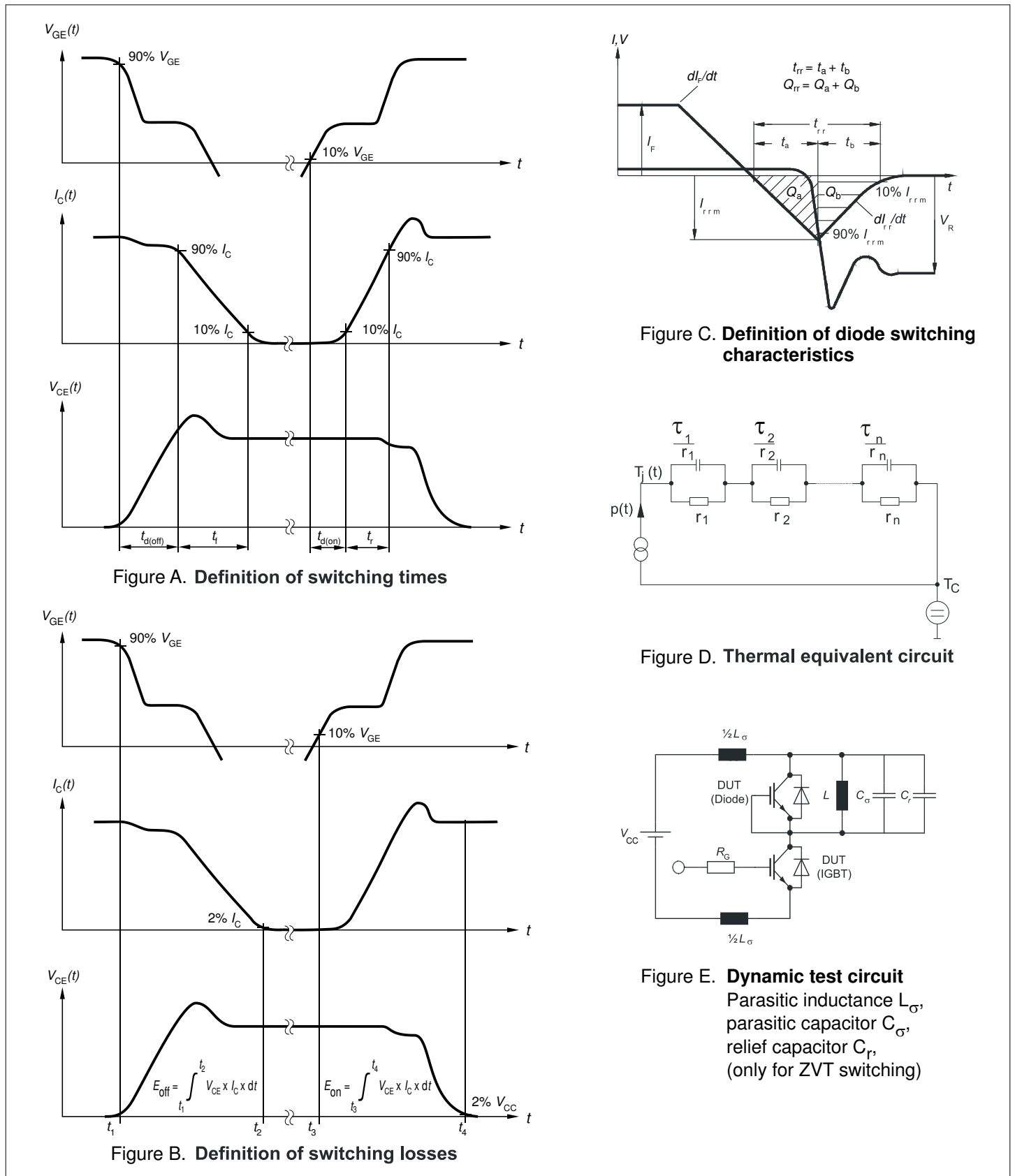

Figure 2

Revision history

Revision history

Document revision	Date of release	Description of changes
0.10	2025-02-07	Target datasheet
0.20	2026-03-18	Preliminary datasheet
1.00	2026-04-01	Final datasheet

Trademarks

All referenced product or service names and trademarks are the property of their respective owners.

Edition 2026-04-01

Published by

Infineon Technologies AG

81726 Munich, Germany

© 2026 Infineon Technologies AG

All Rights Reserved.

Do you have a question about any aspect of this document?

Email: erratum@infineon.com

Document reference

IFX-ABM726-003

Important notice

The information given in this document shall in no event be regarded as a guarantee of conditions or characteristics ("Beschaffheitsgarantie").

With respect to any examples, hints or any typical values stated herein and/or any information regarding the application of the product, Infineon Technologies hereby disclaims any and all warranties and liabilities of any kind, including without limitation warranties of non-infringement of intellectual property rights of any third party.

In addition, any information given in this document is subject to customer's compliance with its obligations stated in this document and any applicable legal requirements, norms and standards concerning customer's products and any use of the product of Infineon Technologies in customer's applications.

The data contained in this document is exclusively intended for technically trained staff. It is the responsibility of customer's technical departments to evaluate the suitability of the product for the intended application and the completeness of the product information given in this document with respect to such application.

Warnings

Due to technical requirements products may contain dangerous substances. For information on the types in question please contact your nearest Infineon Technologies office.

Except as otherwise explicitly approved by Infineon Technologies in a written document signed by authorized representatives of Infineon Technologies, Infineon Technologies' products may not be used in any applications where a failure of the product or any consequences of the use thereof can reasonably be expected to result in personal injury.