

最终数据手册

英飞凌 耐短路 750 V EDT2 IGBT，采用可回流焊接的封装，与 软、快速恢复二极管共同封装

特性

- $V_{CE} = 750\text{ V}$
- $I_C = 200\text{ A}$
- 适用于 470 V V_{DC} 系统，并增加了 400 V V_{DC} 系统的过压裕量
- 极低 $V_{CEsat} = 1.4\text{ V}$ (typ.)， $I_{Cnom} = 200\text{ A}$ ， 25°C
- 短路耐受时间 $t_{sc} = 5\ \mu\text{s}$ ($V_{CE} = 470\text{ V}$ 、 $V_{GE} = 15\text{ V}$)
- 由于回流焊能力，系统 R_{th} 可降低至 40%，增加功率输出
- 短路条件下的自限电流
- 正温度系数和非常紧密的参数分布，易于并联
- 由于 $I_{nom} = 200\text{ A}$ ，减少了需要并联的器件数量
- 优异的并联均流能力
- 平滑的开关特性
- 低栅极电荷 Q_G
- 简单的栅极驱动器设计
- 配备快速软恢复发射极控制二极管 (Emcon3)
- 低EMI特征
- TO247PLUS 封装，高爬电距离 6.6 mm， $400 \leq CTI < 600$
- 高可靠性和使用寿命
- 用于直接母线连接的阻性焊接引脚



潜在应用

- 电动汽车牵引逆变器
- DC母线放电开关
- 汽车辅助驱动

产品验证

- 汽车应用认证。符合AEC-Q101 产品认证
- 符合JEDEC J-STD-020 MSL2 标准的回流焊 260°C

描述

封装引脚定义：

- 引脚 C & 背面 - 集电极
- 引脚 E - 发射极
- 引脚 G - 栅极

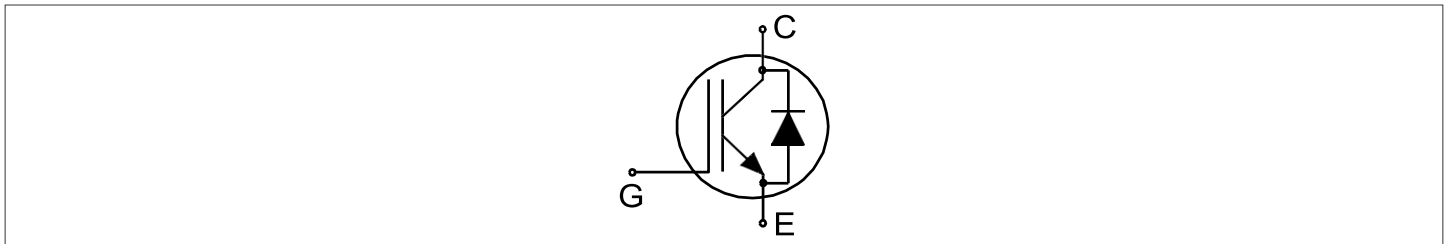

Type	Package	Marking
AIKQB200N75CP2	PG-TO247-3-U02	AKQB20FCP

本数据手册的原文使用英文撰写。为方便起见，英飞凌提供了译文；由于翻译过程中可能使用了自动化工具，英飞凌不保证译文的准确性。为确认准确性，请务必访问 infineon.com 参考最新的英文版本（控制文档）。

目录

	描述	1
	特性	1
	潜在应用.....	1
	产品验证.....	1
	目录	2
1	封装	3
2	IGBT.....	3
3	二极管.....	5
4	特性图.....	7
5	封装外形.....	14
6	测试条件.....	15
	修订记录.....	16
	免责声明.....	17

1 封装

1 封装

表 1 特征值

Parameter	Symbol	Note or test condition	Values			Unit
			Min.	Typ.	Max.	
Internal emitter inductance	L_E	simulated starting from L2 at 1 MHz		4.2		nH
Collector-emitter loop inductance	L_{CE}	simulated starting from L2 at 1 MHz		6		nH
Main emitter pin resistance	R_E	Simulated starting from L2 at 10 kHz		0.43		mΩ
Storage temperature	T_{stg}		-55		150	°C
Soldering temperature	T_{sold}	reflow soldering (MSL2 according to JEDEC J-STD-020)			260	°C
Thermal resistance, junction-ambient	$R_{th(j-a)}$				40	K/W
IGBT thermal resistance, junction-case	$R_{th(j-c)}$			0.12	0.16 ¹⁾	K/W
Diode thermal resistance, junction-case	$R_{th(j-c)}$			0.23	0.3 ¹⁾	K/W

1) 通过仿真定义，不进行生产测试

2 IGBT

表 2 最大额定值

Parameter	Symbol	Note or test condition	Values	Unit
Collector-emitter voltage	V_{CE}	$T_{vj} \geq 25 \text{ °C}$	750	V
DC collector current, limited by T_{vjmax}	I_C	$T_c = 25 \text{ °C}$	200	A
		$T_c = 100 \text{ °C}$	200	
Pulsed collector current, t_p limited by T_{vjmax}	I_{Cpulse}		600	A
Turn-off safe operating area		$V_{CE} \leq 750 \text{ V}, T_{vj} \leq 175 \text{ °C}$	600	A
Gate-emitter voltage	V_{GE}		±20	V
Transient gate-emitter voltage	V_{GE}	$t_p = 10 \text{ μs}, D < 0.01$	±30	V
Short-circuit withstand time	t_{SC}	$V_{CC} \leq 470 \text{ V}, V_{GE} = -8/15 \text{ V}$, Allowed number of short circuits < 1000, Time between short circuits $\geq 1.0 \text{ s}, T_{vj} = 25 \text{ °C}$	5	μs
Power dissipation	P_{tot}	$T_{vj} = 175 \text{ °C}$	$T_c = 25 \text{ °C}$	W
			$T_c = 100 \text{ °C}$	

表3 特征值

Parameter	Symbol	Note or test condition	Values			Unit	
			Min.	Typ.	Max.		
Collector-emitter saturation voltage	V_{CEsat}	$I_C = 200\text{ A}, V_{GE} = 15\text{ V}$	$T_{vj} = 25\text{ }^\circ\text{C}$	1.2	1.4	1.55	V
			$T_{vj} = 175\text{ }^\circ\text{C}$		1.7		
Gate-emitter threshold voltage	V_{GETh}	$I_C = 2.6\text{ mA}, V_{CE} = V_{GE}$		5.2	5.8	6.4	V
Zero gate-voltage collector current	I_{CES}	$V_{CE} = 750\text{ V}, V_{GE} = 0\text{ V}$	$T_{vj} = 25\text{ }^\circ\text{C}$			200	μA
			$T_{vj} = 175\text{ }^\circ\text{C}$		6000		
Gate-emitter leakage current	I_{GES}	$V_{CE} = 0\text{ V}, V_{GE} = 20\text{ V}$				100	nA
Transconductance	g_{fs}	$I_C = 200\text{ A}, V_{CE} = 20\text{ V}$			143		S
Short-circuit collector current	I_{SC}	$V_{CC} \leq 470\text{ V}, V_{GE} = -8/15\text{ V}, t_{SC} \leq 5\text{ }\mu\text{s},$ Allowed number of short circuits < 1000, Time between short circuits $\geq 1.0\text{ s}, T_{vj} = 25\text{ }^\circ\text{C}$	$T_{vj} = 175\text{ }^\circ\text{C}$		1250		A
Input capacitance	C_{ies}	$V_{CE} = 25\text{ V}, V_{GE} = 0\text{ V}, f = 100\text{ kHz}$			20500		pF
Output capacitance	C_{oes}	$V_{CE} = 25\text{ V}, V_{GE} = 0\text{ V}, f = 100\text{ kHz}$			540		pF
Reverse transfer capacitance	C_{res}	$V_{CE} = 25\text{ V}, V_{GE} = 0\text{ V}, f = 100\text{ kHz}$			95		pF
Gate charge	Q_G	$V_{CC} = 600\text{ V}, I_C = 200\text{ A}, V_{GE} = -8/15\text{ V}$			1270		nC
Turn-on delay time	$t_{d(on)}$	$V_{CC} = 470\text{ V}, V_{GE} = -8/15\text{ V}, R_{G(on)} = 5\text{ }\Omega, R_{G(off)} = 5\text{ }\Omega$	$T_{vj} = 25\text{ }^\circ\text{C}, I_C = 200\text{ A}$		89		ns
			$T_{vj} = 175\text{ }^\circ\text{C}, I_C = 200\text{ A}$		85		
Rise time (inductive load)	t_r	$V_{CC} = 470\text{ V}, V_{GE} = -8/15\text{ V}, R_{G(on)} = 5\text{ }\Omega, R_{G(off)} = 5\text{ }\Omega$	$T_{vj} = 25\text{ }^\circ\text{C}, I_C = 200\text{ A}$		120		ns
			$T_{vj} = 175\text{ }^\circ\text{C}, I_C = 200\text{ A}$		117		
Turn-off delay time	$t_{d(off)}$	$V_{CC} = 470\text{ V}, V_{GE} = -8/15\text{ V}, R_{G(on)} = 5\text{ }\Omega, R_{G(off)} = 5\text{ }\Omega$	$T_{vj} = 25\text{ }^\circ\text{C}, I_C = 200\text{ A}$		266		ns
			$T_{vj} = 175\text{ }^\circ\text{C}, I_C = 200\text{ A}$		284		
Fall time (inductive load)	t_f	$V_{CC} = 470\text{ V}, V_{GE} = -8/15\text{ V}, R_{G(on)} = 5\text{ }\Omega, R_{G(off)} = 5\text{ }\Omega$	$T_{vj} = 25\text{ }^\circ\text{C}, I_C = 200\text{ A}$		46		ns
			$T_{vj} = 175\text{ }^\circ\text{C}, I_C = 200\text{ A}$		60		

(表格续下页.....)

3 二极管

表 3 (续) 特征值

Parameter	Symbol	Note or test condition	Values			Unit	
			Min.	Typ.	Max.		
Turn-on energy ¹⁾	E_{on}	$V_{CC} = 470 \text{ V}, V_{GE} = -8/15 \text{ V}, R_{G(on)} = 5 \Omega, R_{G(off)} = 5 \Omega$	$T_{vj} = 25 \text{ }^\circ\text{C}, I_C = 200 \text{ A}$		15.3		mJ
			$T_{vj} = 175 \text{ }^\circ\text{C}, I_C = 200 \text{ A}$		16.3		
Turn-off energy	E_{off}	$V_{CC} = 470 \text{ V}, V_{GE} = -8/15 \text{ V}, R_{G(on)} = 5 \Omega, R_{G(off)} = 5 \Omega$	$T_{vj} = 25 \text{ }^\circ\text{C}, I_C = 200 \text{ A}$		7		mJ
			$T_{vj} = 175 \text{ }^\circ\text{C}, I_C = 200 \text{ A}$		8.1		
Total switching energy	E_{ts}	$V_{CC} = 470 \text{ V}, V_{GE} = -8/15 \text{ V}, R_{G(on)} = 5 \Omega, R_{G(off)} = 5 \Omega$	$T_{vj} = 25 \text{ }^\circ\text{C}, I_C = 200 \text{ A}$		22.3		mJ
			$T_{vj} = 175 \text{ }^\circ\text{C}, I_C = 200 \text{ A}$		24.4		
Operating junction temperature	T_{vj}			-40		175	$^\circ\text{C}$

1) 包括反向恢复电流引起的 IGBT 损耗

3 二极管

表 4 最大额定值

Parameter	Symbol	Note or test condition	Values	Unit	
Diode forward current, limited by T_{vjmax}	I_F		$T_c = 25 \text{ }^\circ\text{C}$	200	A
			$T_c = 100 \text{ }^\circ\text{C}$	200	
Diode pulsed current, t_p limited by T_{vjmax}	I_{Fpulse}		600	A	
Power dissipation	P_{tot}	$T_{vj} = 175 \text{ }^\circ\text{C}$	$T_c = 25 \text{ }^\circ\text{C}$	500	W
			$T_c = 100 \text{ }^\circ\text{C}$	250	

表 5 特征值

Parameter	Symbol	Note or test condition	Values			Unit	
			Min.	Typ.	Max.		
Diode forward voltage	V_F	$I_F = 200 \text{ A}$	$T_{vj} = 25 \text{ }^\circ\text{C}$	1.6	1.8	2	V
			$T_{vj} = 175 \text{ }^\circ\text{C}$		1.9		

(表格续下页.....)

表 5 (续) 特征值

Parameter	Symbol	Note or test condition	Values			Unit	
			Min.	Typ.	Max.		
Diode reverse recovery charge	Q_{rr}	$V_R = 470 \text{ V}, R_{G(on)} = 5 \text{ } \Omega$	$T_{vj} = 25 \text{ } ^\circ\text{C},$ $I_F = 200 \text{ A},$ $-di_F/dt = 1060 \text{ A}/\mu\text{s}$		4.7		μC
			$T_{vj} = 175 \text{ } ^\circ\text{C},$ $I_F = 200 \text{ A},$ $-di_F/dt = 1067 \text{ A}/\mu\text{s}$		7.5		
Diode peak reverse recovery current	I_{rrm}	$V_R = 470 \text{ V}, R_{G(on)} = 5 \text{ } \Omega$	$T_{vj} = 25 \text{ } ^\circ\text{C},$ $I_F = 200 \text{ A},$ $-di_F/dt = 1060 \text{ A}/\mu\text{s}$		41		A
			$T_{vj} = 175 \text{ } ^\circ\text{C},$ $I_F = 200 \text{ A},$ $-di_F/dt = 1067 \text{ A}/\mu\text{s}$		56		
Reverse recovery energy	E_{rec}	$V_R = 470 \text{ V}, R_{G(on)} = 5 \text{ } \Omega,$ $L_\sigma = 50 \text{ nH}, C_\sigma = 30 \text{ pF}$	$T_{vj} = 25 \text{ } ^\circ\text{C},$ $I_F = 200 \text{ A},$ $-di_F/dt = 1060 \text{ A}/\mu\text{s}$		1.1		mJ
			$T_{vj} = 175 \text{ } ^\circ\text{C},$ $I_F = 200 \text{ A},$ $-di_F/dt = 1067 \text{ A}/\mu\text{s}$		1.9		
Operating junction temperature	T_{vj}			-40		175	$^\circ\text{C}$

注： 为了获得最佳的使用寿命和可靠性，英飞凌建议工作条件不超过本数据手册中所述最大额定值的 80%。

除非另有规定，电气特性均为 $T_{vj} = 25^\circ\text{C}$ 。

动态测试电路，寄生电感 $L_\sigma = 50 \text{ nH}$ ，寄生电容 $C_\sigma = 30 \text{ pF}$ ，来自图 E。能量损耗包括“拖尾”和二极管反向恢复。

4 特性图

4 特性图

Power dissipation as a function of case temperature

$P_{tot} = f(T_c)$
 $T_{vj} \leq 175\text{ }^\circ\text{C}$

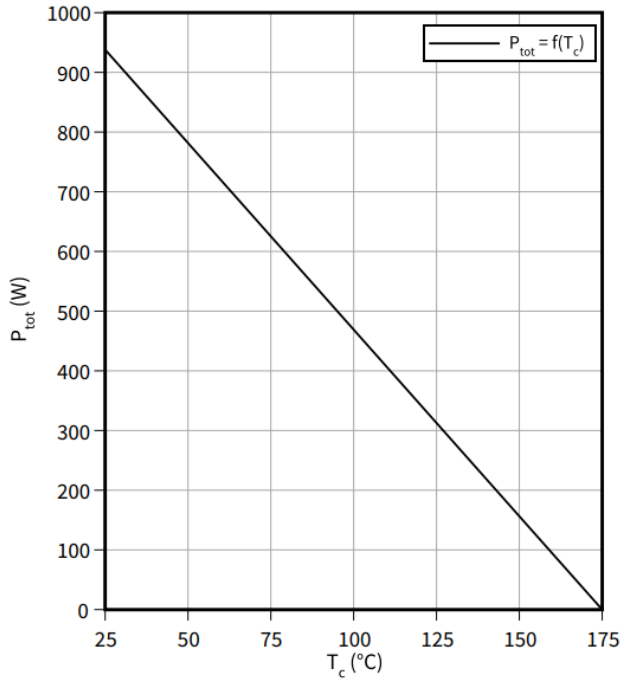

Collector current as a function of case temperature

$I_c = f(T_c)$
 $T_{vj} \leq 175\text{ }^\circ\text{C}, V_{GE} = 15\text{ V}$

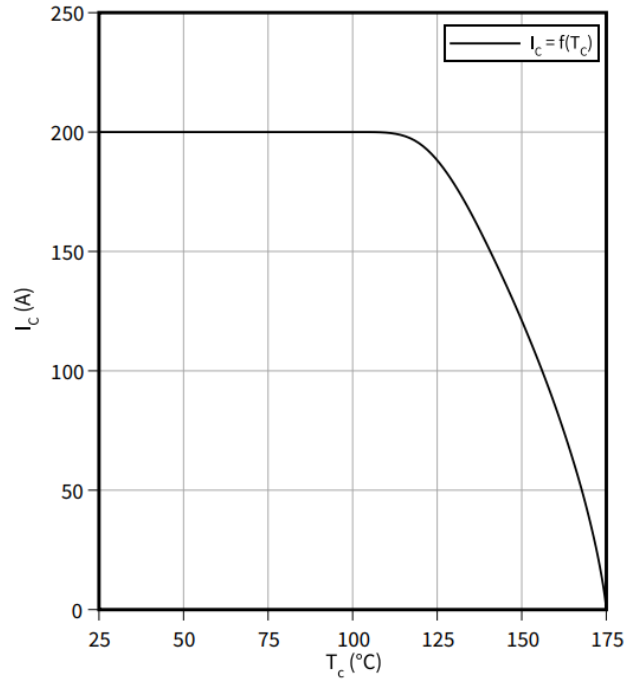

Typical output characteristic

$I_c = f(V_{CE})$
 $T_{vj} = 25\text{ }^\circ\text{C}$

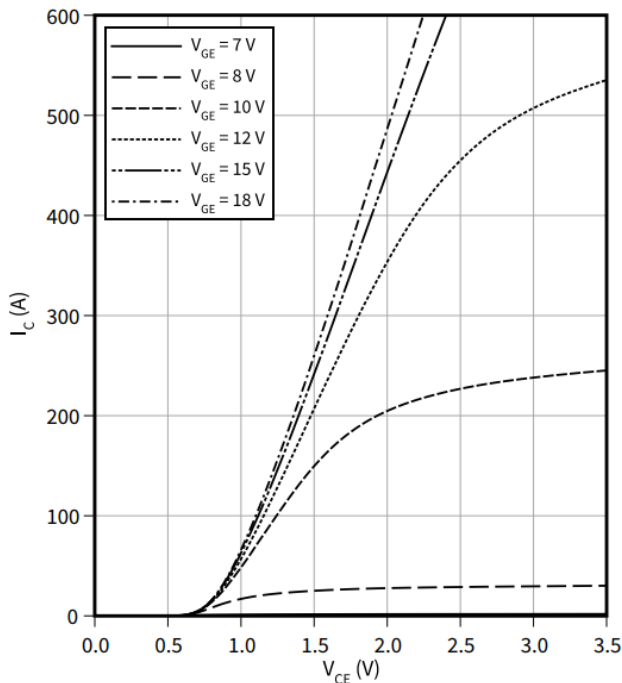

Typical output characteristic

$I_c = f(V_{CE})$
 $T_{vj} = 175\text{ }^\circ\text{C}$

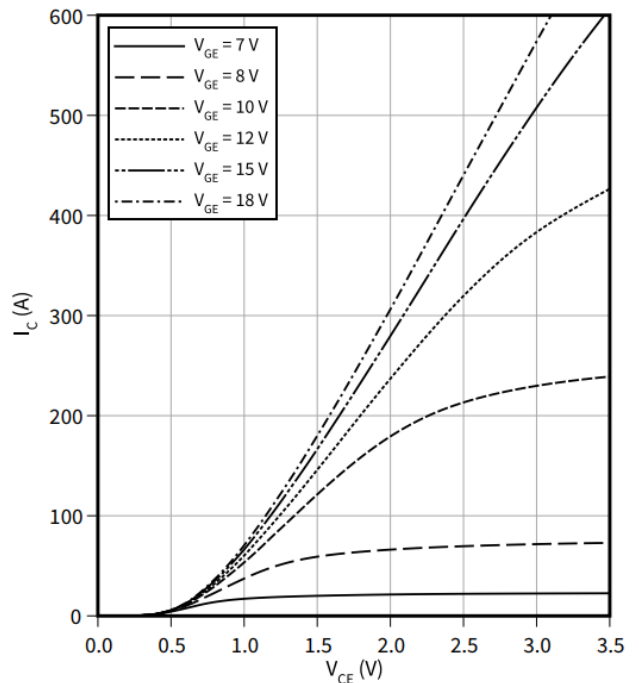

4 特性图

Typical transfer characteristic

$I_C = f(V_{GE})$

$V_{CE} = 20\text{ V}$

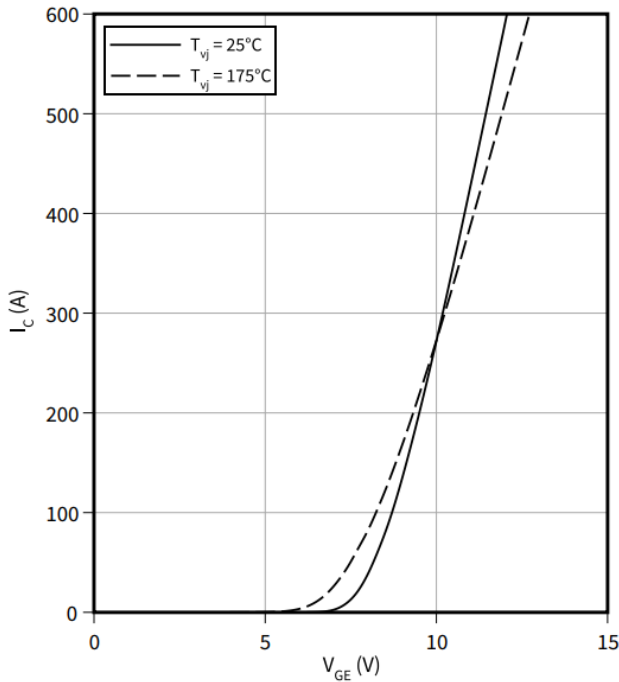

Typical collector-emitter saturation voltage as a function of junction temperature

$V_{CEsat} = f(T_{vj})$

$V_{GE} = 15\text{ V}$

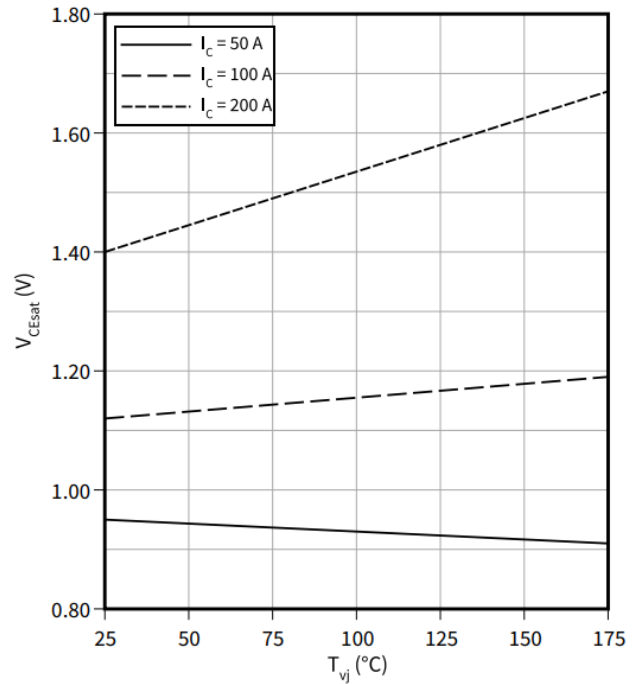

Gate-emitter threshold voltage as a function of junction temperature

$V_{GEth} = f(T_{vj})$

$I_C = 2.6\text{ mA}$

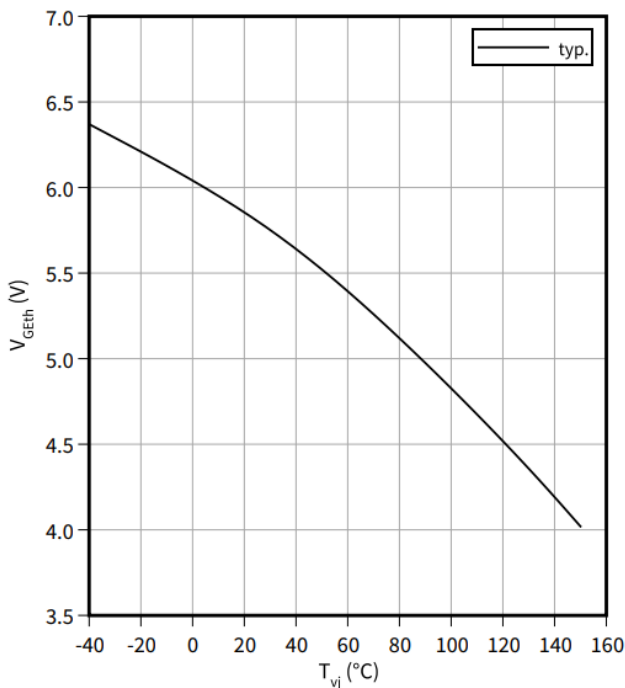

Typical switching times as a function of collector current

$t = f(I_C)$

$V_{CC} = 470\text{ V}, T_{vj} = 175^\circ\text{C}, V_{GE} = -8/15\text{ V}, R_G = 5\ \Omega$

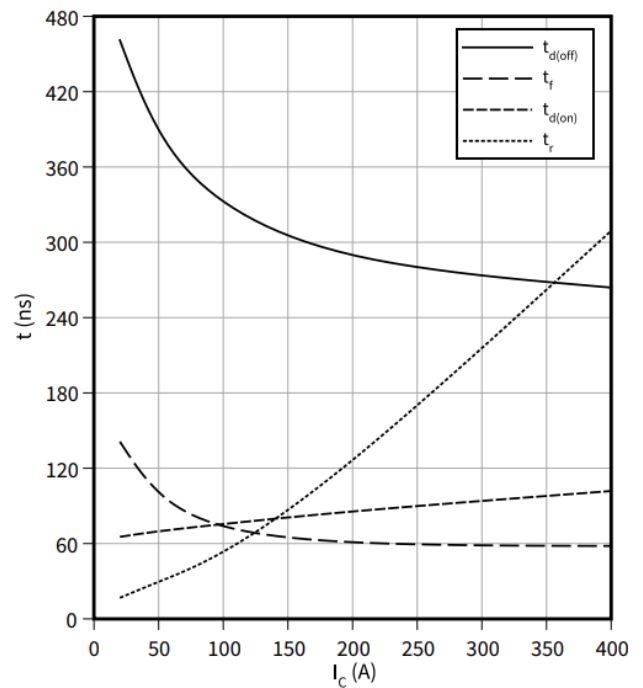

4 特性图

Typical switching times as a function of gate resistor

$t = f(R_G)$

$I_C = 200\text{ A}$, $V_{CC} = 470\text{ V}$, $T_{vj} = 175\text{ }^\circ\text{C}$, $V_{GE} = -8/15\text{ V}$

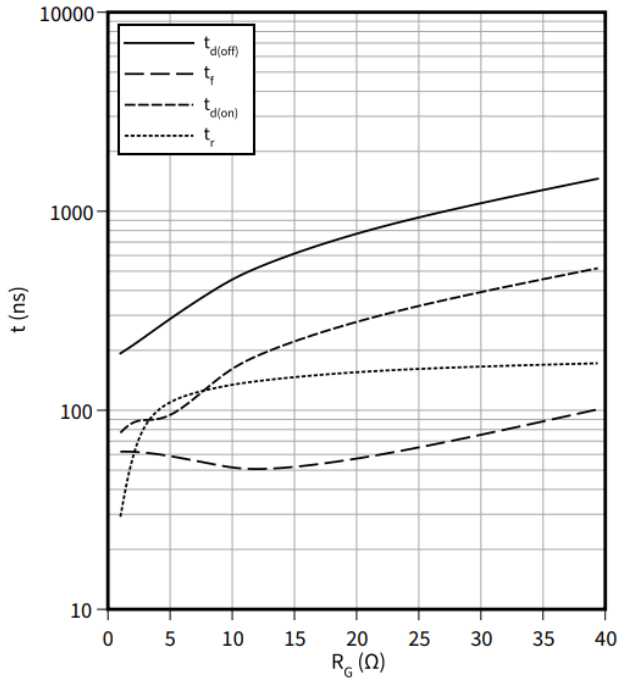

Typical switching times as a function of junction temperature

$t = f(T_{vj})$

$I_C = 200\text{ A}$, $V_{CC} = 470\text{ V}$, $V_{GE} = -8/15\text{ V}$, $R_G = 5\text{ }\Omega$

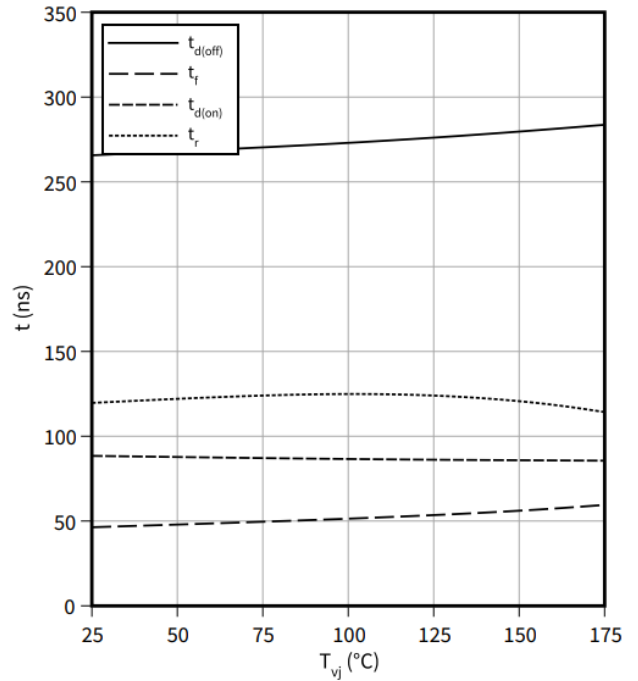

Typical switching energy losses as a function of collector current

$E = f(I_C)$

$V_{CC} = 470\text{ V}$, $T_{vj} = 175\text{ }^\circ\text{C}$, $V_{GE} = -8/15\text{ V}$, $R_G = 5\text{ }\Omega$

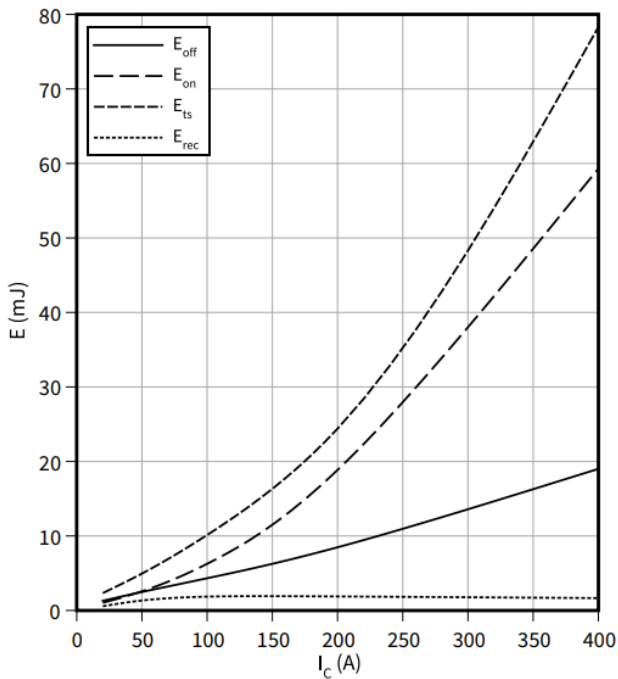

Typical switching energy losses as a function of gate resistor

$E = f(R_G)$

$I_C = 200\text{ A}$, $V_{CC} = 470\text{ V}$, $T_{vj} = 175\text{ }^\circ\text{C}$, $V_{GE} = -8/15\text{ V}$

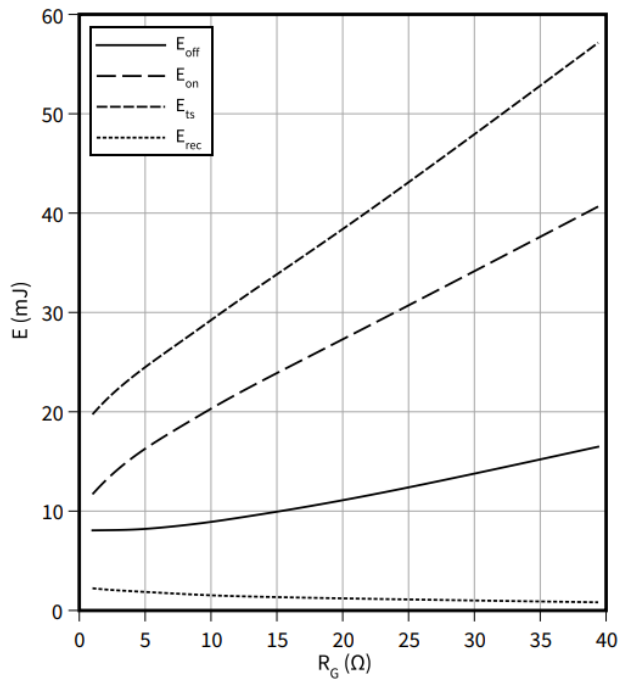

4 特性图

Typical switching energy losses as a function of junction temperature

$E = f(T_{vj})$

$I_C = 200\text{ A}, V_{CC} = 470\text{ V}, V_{GE} = -8/15\text{ V}, R_G = 5\ \Omega$

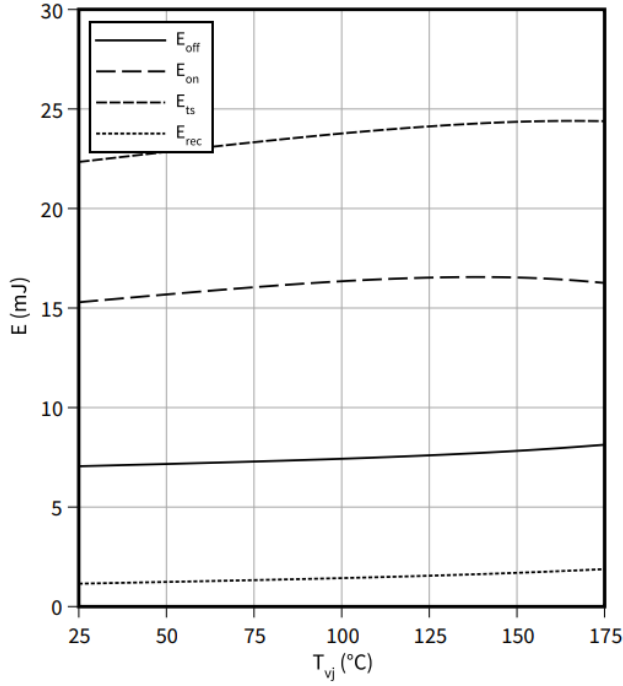

Typical switching energy losses as a function of collector emitter voltage

$E = f(V_{CE})$

$I_C = 200\text{ A}, V_{GE} = -8/15\text{ V}, T_{vj} = 175\text{ °C}, R_G = 5\ \Omega$

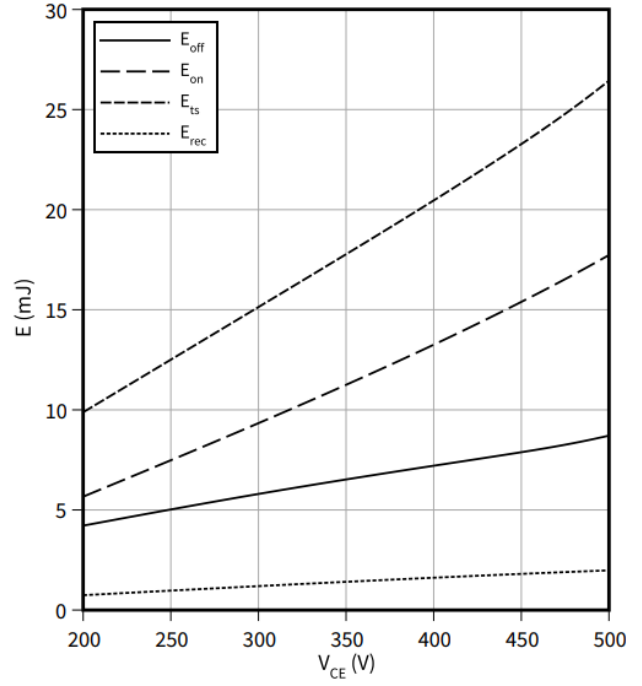

Typical gate charge

$V_{GE} = f(Q_G)$

$I_C = 200\text{ A}$

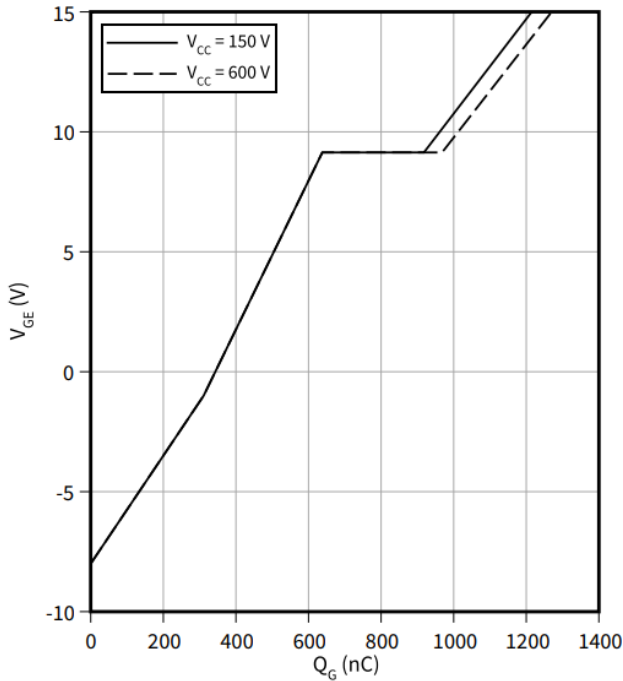

Typical capacitance as a function of collector-emitter voltage

$C = f(V_{CE})$

$f = 100\text{ kHz}, V_{GE} = 0\text{ V}$

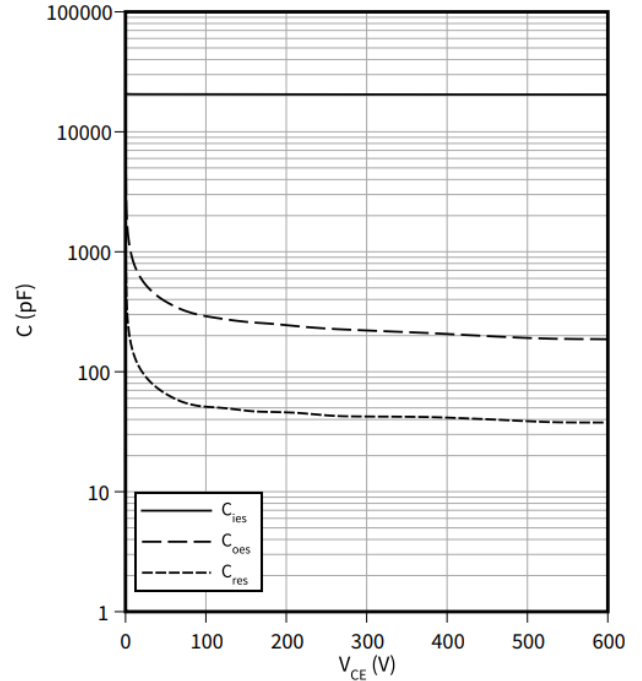

4 特性图

Typical short circuit collector current as a function of gate-emitter voltage

$I_{C(SC)} = f(V_{GE})$
 $T_{vj} \leq 175\text{ }^\circ\text{C}$, $V_{CE} \leq 470\text{ V}$

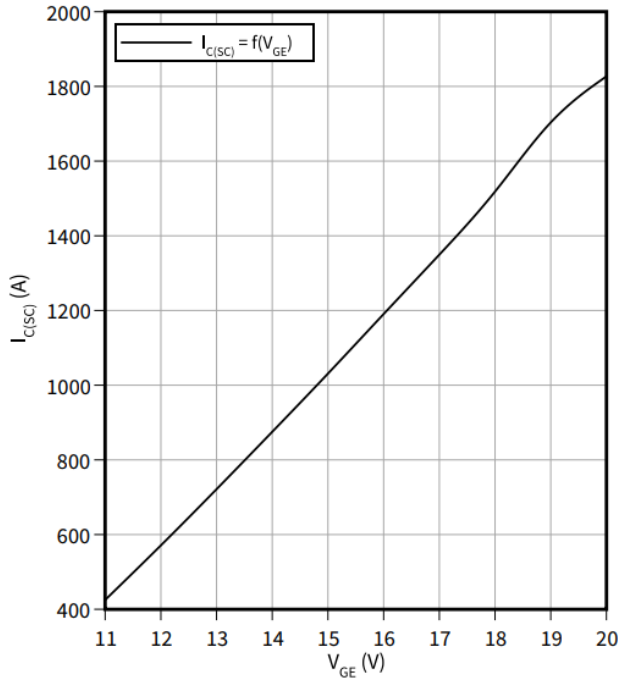

Short circuit withstand time as a function of gate-emitter voltage

$t_{SC} = f(V_{GE})$
 $T_{vj} \leq 175\text{ }^\circ\text{C}$, $V_{CE} \leq 470\text{ V}$

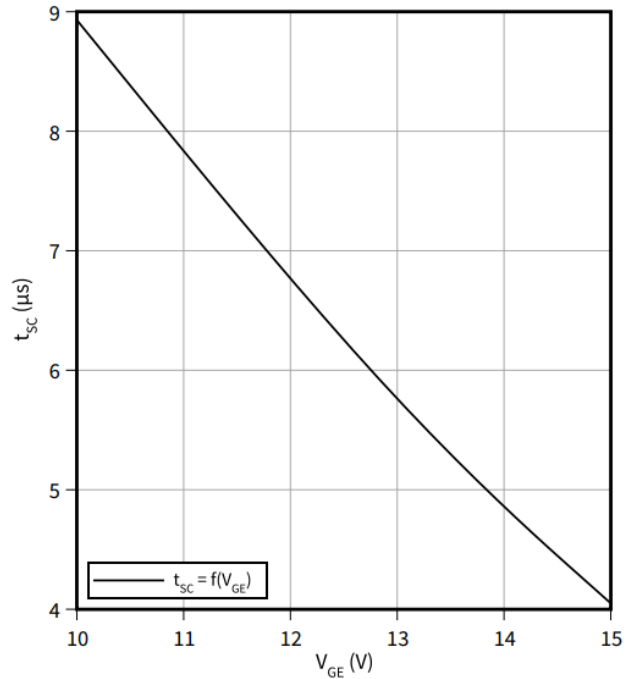

IGBT typical transient thermal impedance as a function of pulse width

$Z_{th(j-c)} = f(t_p)$
 $D = t_p/T$

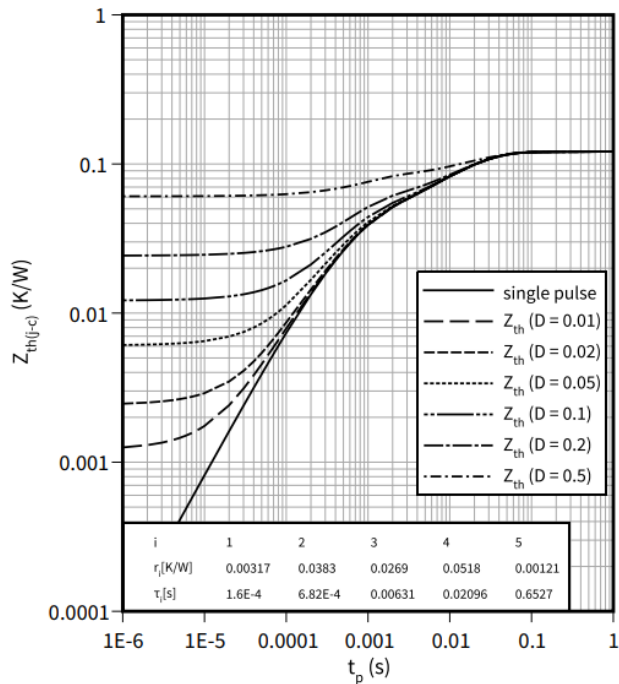

Diode typical transient thermal impedance as a function of pulse width

$Z_{th(j-c)} = f(t_p)$
 $D = t_p/T$

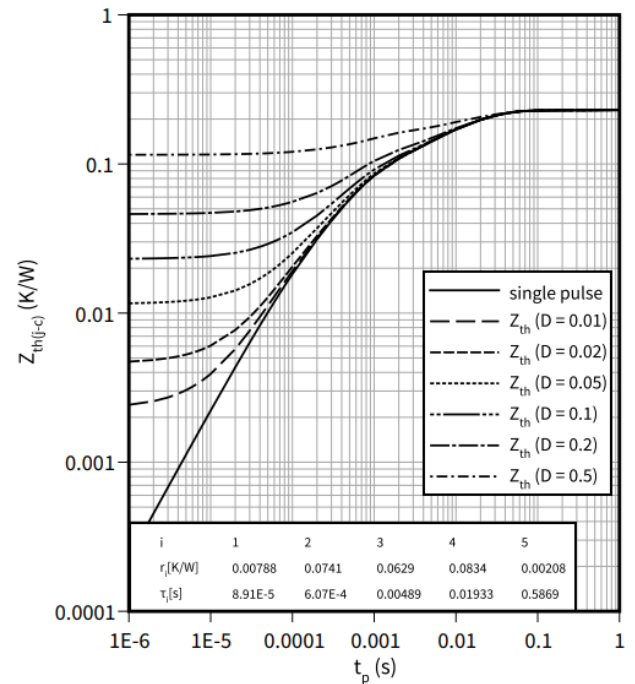

4 特性图

Typical diode forward current as a function of forward voltage

$I_F = f(V_F)$

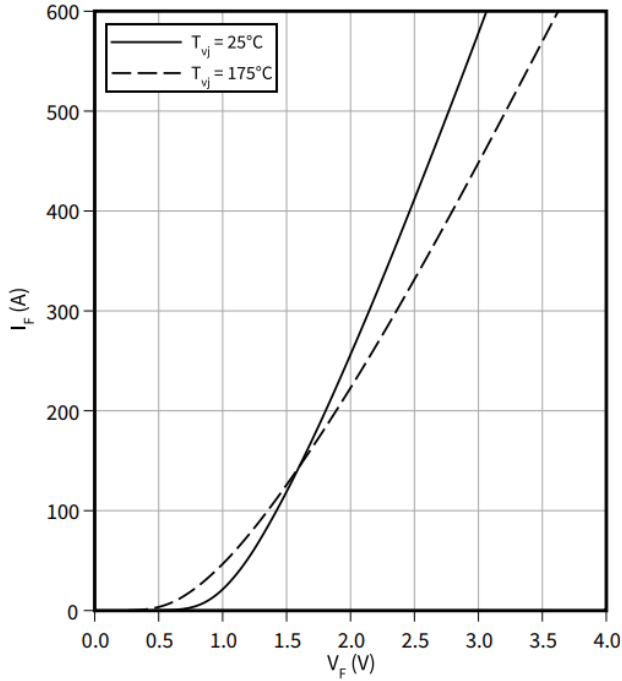

Typical diode forward voltage as a function of junction temperature

$V_F = f(T_{vj})$

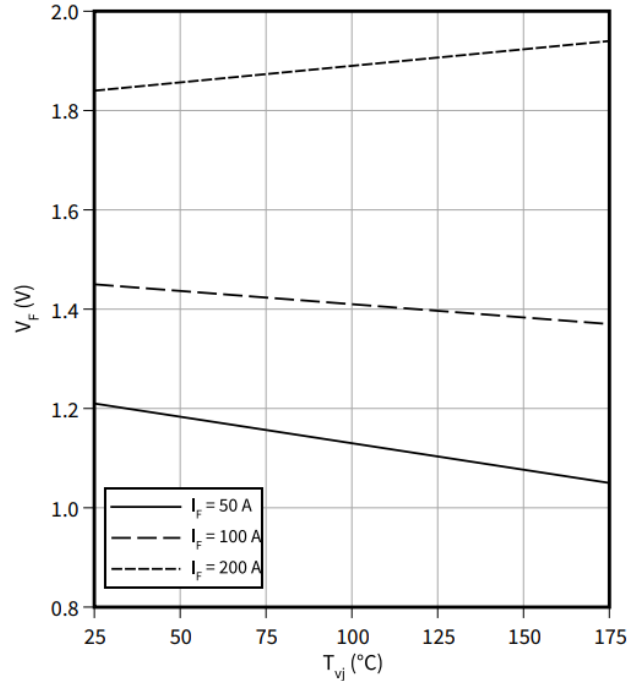

Typical reverse recovery time as a function of diode current slope

$t_{rr} = f(di_F/dt)$

$V_R = 470\text{ V}$, $I_F = 200\text{ A}$

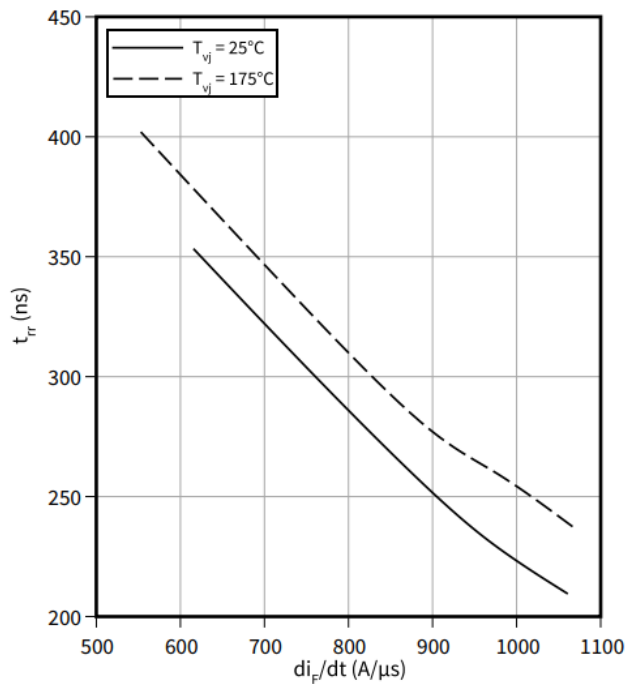

Typical reverse recovery charge as a function of diode current slope

$Q_{rr} = f(di_F/dt)$

$V_R = 470\text{ V}$, $I_F = 200\text{ A}$

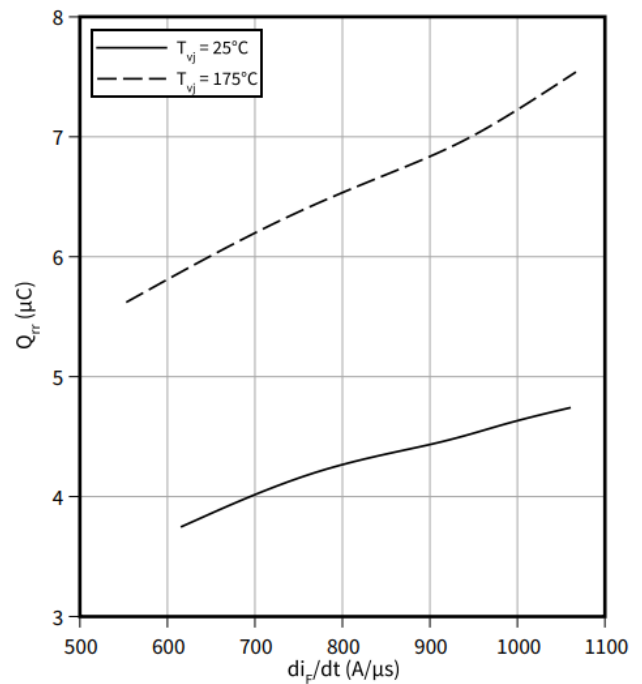

4 特性图

Typical reverse recovery current as a function of diode current slope

$I_{rrm} = f(di_F/dt)$

$V_R = 470 \text{ V}, I_F = 200 \text{ A}$

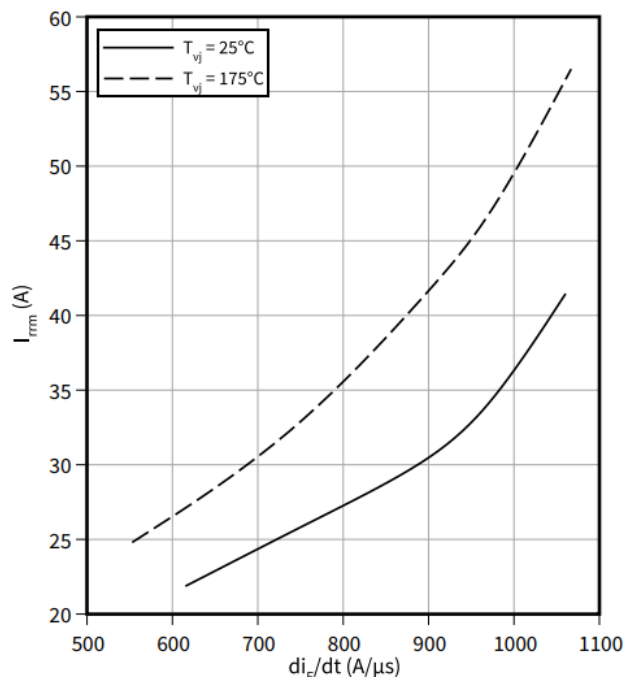

Typical diode peak rate of fall of reverse recovery current as a function of diode current slope

$di_{rr}/dt = f(di_F/dt)$

$V_R = 470 \text{ V}, I_F = 200 \text{ A}$

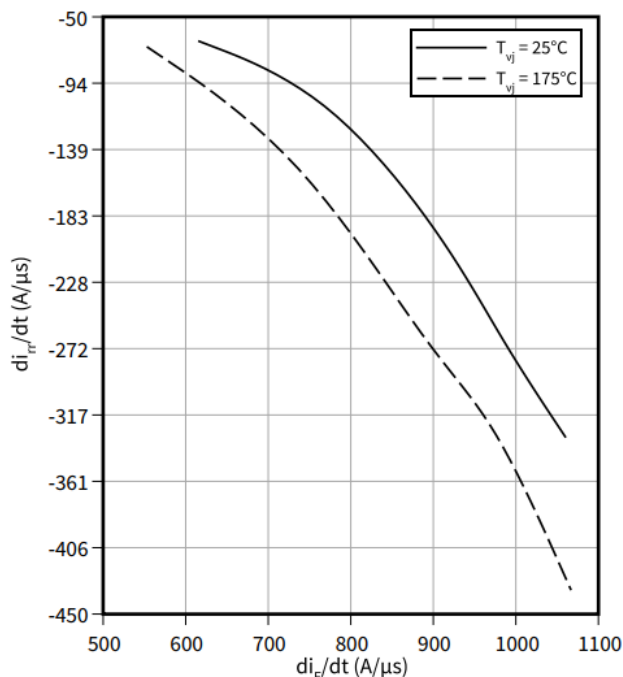

Typical reverse energy losses as a function of diode current slope

$E_{rec} = f(di_F/dt)$

$V_R = 470 \text{ V}, I_F = 200 \text{ A}$

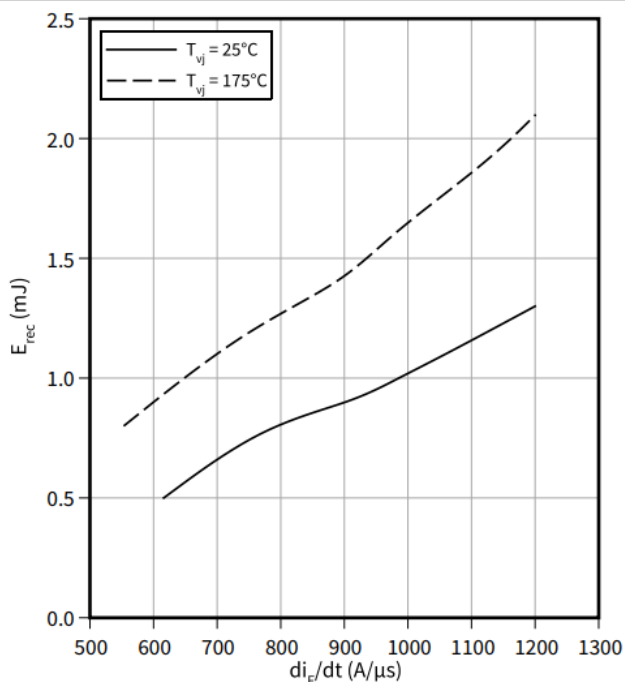

5 封装外形

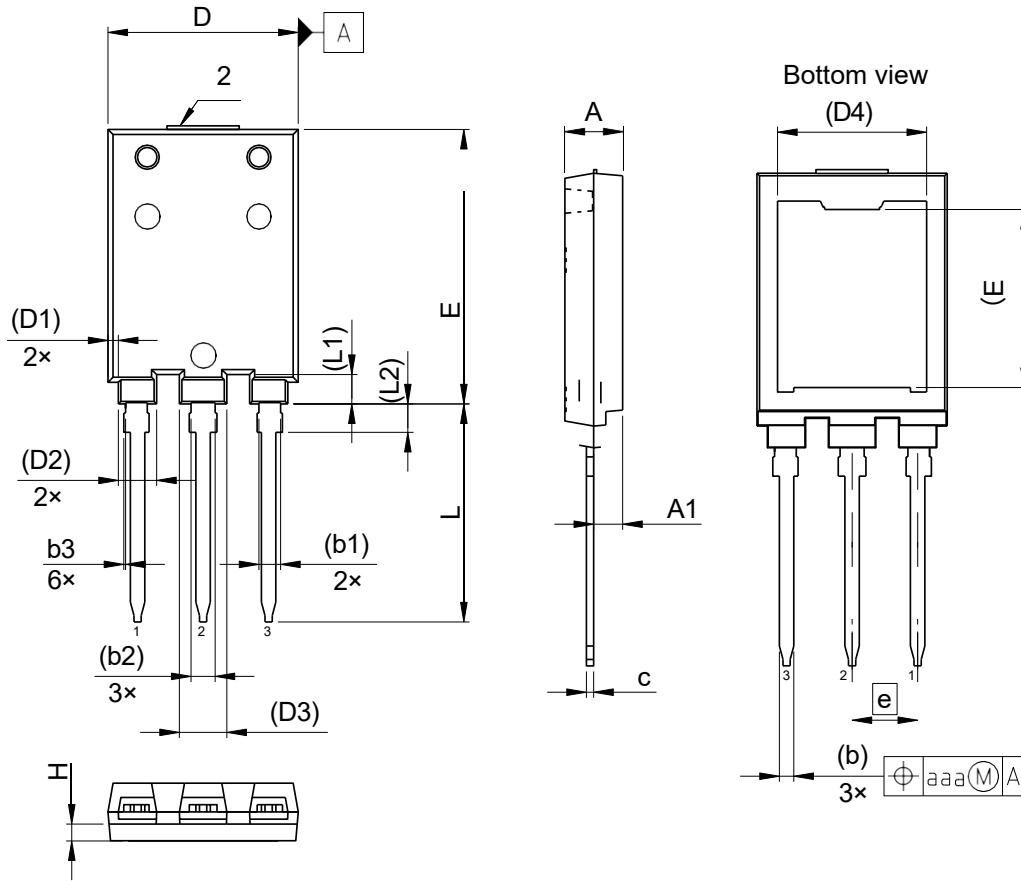

PACKAGE - GROUP		
NUMBER: PG-TO247-3-U02		
DIMENSIONS	MILLIMETERS	
	MIN.	MAX.
A	4.7	4.9
A1	2.16	2.66
b	1.2	
b1	1.8	
b2	2	
b3	0	0.15
c	0.5	0.7
D	15.7	15.9
D1	0.86	
D2	3.18	

DIMENSIONS	MILLIMETERS	
	MIN.	MAX.
D3	3.94	
D4	12.38	
E	22.7	22.9
E1	14.79	
e	5.44	
H	1.3	1.5
L	18.01	18.21
L1	2.44	
L2	2.36	
aaa	0.25	

1) All metal surfaces tin plated except area of cut

2) Mold gate protrusion after degating

All dimensions are in units mm

The drawing is in compliance with ISO 128-30, Projection Method 3 [⊕] [A]

Drawing according to ISO 8015, general tolerances

图 1

6 测试条件



图 2

修订记录

Document revision	Date of release	Description of changes
0.10	2023-02-21	Target datasheet
0.20	2024-02-22	Preliminary datasheet
1.00	2024-07-25	Final datasheet
1.10	2025-06-11	Transient thermal impedance plots, package naming convention, and qualification labels updated according to the latest guidelines

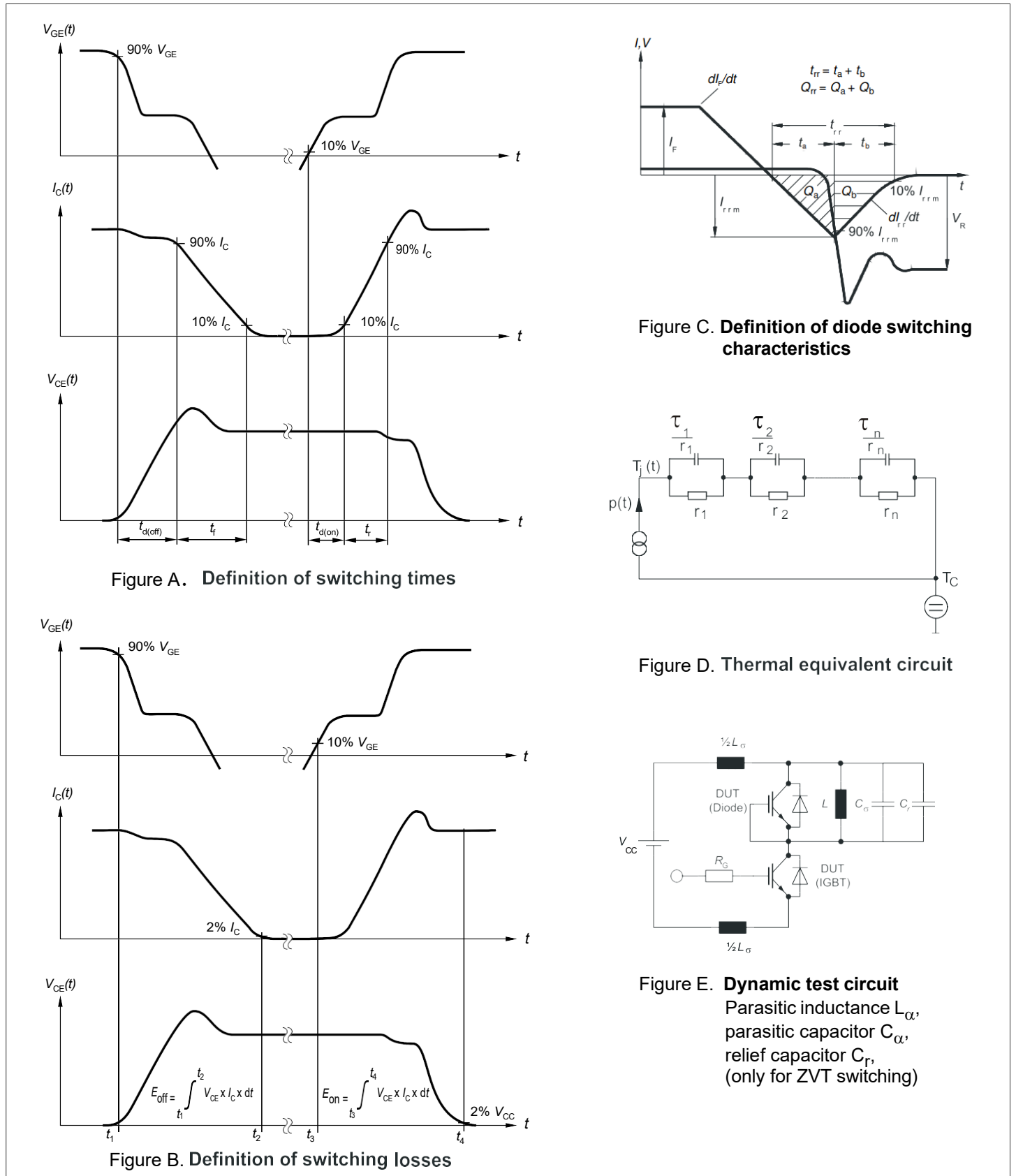

免责声明

请注意，本文件的原文使用英文撰写，为方便客户浏览英飞凌提供了中文译文。该中文译文仅供参考，并不可作为任何论点之依据。

由于翻译过程中可能使用了自动化程序，以及语言翻译和转换过程中的差异，最后的中文译文与最新的英文版本原文含义可能存在不尽相同之处。

因此，我们同时提供该中文译文版本的最新英文原文供您阅读，请参见 <http://www.infineon.com>

英文原文和中文译文版本之间若存有任何歧异，以最新的英文版本为准，并且仅认可英文版本为正式文件。

您如果使用本文件，即表示您同意并理解上述说明。英飞凌不对因翻译过程中可能存在的任何不完整或不准确信息而产生的任何直接或间接损失或损害负责。英飞凌不承担中文译文版本的完整性和准确性责任。如果您不同意上述说明，请不要使用本文件。

Trademarks

All referenced product or service names and trademarks are the property of their respective owners.

重要通知

Infineon Technologies AG 及其关联公司（以下简称“英飞凌”）销售或提供和交付的产品（可能也包括样品，且可能由硬件或软件或两者组成）（以下简称“产品”），应遵守客户与英飞凌签订的框架供应合同或其他书面协议的条款和条件，如无上合同或其他书面协议，则应遵守适用的英飞凌销售条件。只有在英飞凌明确书面同意的情况下，客户的一般条款和条件或对适用的英飞凌销售条件的偏离才对英飞凌具有约束力。

为避免疑义，英飞凌不承担侵犯第三方权利的所有保证和默示保证，例如对特定用途/目的的适用性或适销性的保证。

英飞凌对与样品、应用或客户对任何产品的具体使用有关的任何信息或本文中给出的任何示例或典型值概不负责。

本文件中包含的数据仅供具有技术资格和技能的客户代表使用。客户有责任评估产品对预期应用和客户特定用途的适用性，并在预期应用和客户特定用途中验证本文件中包含的所有相关技术数据。客户有责任正确设计、编程和测试预期应用的功能性和安全性，并遵守与其使用相关的法律要求。

除非英飞凌另行明确批准，否则产品不得用于任何因产品故障或使用产品的任何后果可合理预期会导致人身伤害的应用。但是，上述规定并不妨碍客户在英飞凌明确设计和销售的使用领域中使用任何产品，但是客户对应用负有全部责任。

英飞凌明确保留根据适用法律，如《德国版权法》（UrhG）第 44b 条，将其内容用于商业资料和数据探勘（TDM）的权利。

如果产品包含安全功能：

由于任何计算设备都不可能绝对安全，尽管产品采取了安全措施，但英飞凌不保证产品不会被入侵、数据不会被盗或遗失，或不会发生其他漏洞（以下简称“安全漏洞”），英飞凌对任何安全漏洞不承担任何责任。

如果本文档包含或引用软件：

根据美国、德国和世界其他国家的知识产权法律和条约，该软件归英飞凌所有。英飞凌保留所有权利。因此，您只能按照软件附带的软件授权协议的规定使用本软件。

如果没有适用的软件授权协议，英飞凌特此授予您个人的、非排他性的、不可转让的软件知识产权授权（无权转授权）：(a) 对于以源代码形式提供的软件，仅在贵组织内部修改和复制该软件用于英飞凌硬件产品；及 (b) 对于以二进制代码 (binary code) 形式对外向终端用户分发该软件，仅得用于英飞凌硬件产品。禁止对本软件进行任何其他使用、复制、修改、翻译或编译。有关产品、技术、交货条款和条件以及价格的详细信息，请联系离您最近的英飞凌办公室或访问 <https://www.infineon.com>。

版本 2026-04-20

Infineon Technologies AG 出版，
德国 Neubiberg 85579

版权 © 2026 Infineon Technologies AG
及其关联公司。
保留所有权利。

Do you have a question about this
document?

Email:

erratum@infineon.com