

# Quickstart Guide for Inverter Evaluation Kit

Inverter Evaluation Kit for HybridPACK™ Drive G2 Power Modules

## About this document

This application note is a Quickstart Guide for the inverter evaluation kits with the HybridPACK™ Drive G2 power modules. The inverter evaluation kit is available with latest IGBT/Diode as well as with SIC MOSFET chip technologies. An overview about the inverter evaluation kits, short description of most important interfaces and introduction of basic inverter operation is given.

## Scope and purpose

The inverter evaluation kits were designed to support customers during their first steps in designing applications with the HybridPACK™ Drive G2 power modules, EiceDriver™ gate drivers, Xensiv™ current sensors and Aurix™ Microcontrollers. The inverter kits can provide a good starting point for project specific inverter developments. Furthermore, practical experience from the power module operation as well as the gate driver features and performance tests of phase current sensors can be obtained in the lab at a minimum effort by using such evaluation tools. **Before getting started it is mandatory to read and understand the safety warnings (section 1.1).**

## Intended audience

Experienced engineers designing inverters with HybridPACK™ Drive G2.

## Table of Contents

<b>1</b>	<b>Introduction.....</b>	<b>3</b>
1.1	Safety Warning for Evaluation Kit.....	3
1.2	Information Export Control Classification 3A225.....	4
1.3	Block Diagram .....	4
<b>2</b>	<b>Overview Evaluation Tools and Order Numbers .....</b>	<b>5</b>
2.1	Type designation tree for evaluation tools .....	6
2.2	Recommended Lab Equipment .....	7
2.3	Recommended Operating Conditions.....	7
2.4	Limitations of the Evaluation Kit .....	8
<b>3</b>	<b>Interface Descriptions .....</b>	<b>9</b>
3.1	Interfaces Logic Board .....	9
3.2	Interfaces Gate Driver Boards (IGBT Versions) .....	10
3.3	Interfaces Gate Driver Boards (SIC MOSFET Versions).....	11
<b>4</b>	<b>Quickstart Guide.....</b>	<b>12</b>
4.1	Typical Setup for Inverter Load Tests.....	12
4.2	DEMO Mode (Inverter Operation without Communication) .....	13
4.2.1	DEMO Mode: Adjusting the Modulation Index.....	14
4.2.2	DEMO Mode: Adjusting the Output Frequency .....	15
4.3	Inverter Tests (Introduction Open Loop mode) .....	16
4.4	Inverter Kit Parameter Adjustment .....	17
4.5	Information for Calibration of Phase Current Sensors .....	18
<b>5</b>	<b>Trouble Shooting and further detailed Information .....</b>	<b>19</b>
5.1	Communication with the Evaluation Kit .....	19
5.1.1	USB serial Communication.....	19
5.1.2	CAN bus Communication.....	19
5.2	Software flashing into Logicboards via Memtool .....	21

# Quickstart Guide for Inverter Evaluation Kit

## Inverter Evaluation Kit for HybridPACK™ Drive G2 Power Modules

---



### Introduction

5.3	New Boards Inizialization.....	22
5.4	Extract CAN0 Messages .....	23
5.4.1	RX Messages (Receive by the Logicboard) .....	23
5.4.2	TX Messages (Transmitted by the Logicboard) .....	24
5.5	FAQ Frequent Asked Questions .....	26
<b>6</b>	<b>References and Revision History .....</b>	<b>27</b>

## Introduction

# 1 Introduction

The inverter evaluation kits for the HybridPACK™ Drive G2 power modules support engineers during their design-in activities. The kits use latest EiceDriver™ gate drivers and Xensiv™ current sensors implemented in the Swoboda phase current sensors. The inverter kit has open design files, which makes it very convenient for evaluation purpose and cross reference tests.

**Please read and understand the manual and following safety warnings in section 1.1.**

## 1.1 Safety Warning for Evaluation Kit

**The design operates with unprotected high voltages.** Therefore, the Evaluation Tools may only be handled by persons with sufficient electrical engineering training and experience. The customer assumes all responsibility and liability for its correct handling and/or use of the Evaluation Kit and undertakes to indemnify and hold Infineon Technologies harmless from any third party claim in connection with or arising out of the use and/or handling of the Evaluation Kit by the customer.

The Evaluation Kit is a sample to be used by the customer solely for the purpose of evaluation and testing. It is not a commercialized product and shall not be used for series production. The Evaluation Kit is thus not intended to meet any automotive qualifications. Due to the purpose of the system, it is not subjected to the same procedures regarding Returned Material Analysis (RMA), Process Change Notification (PCN) and Product Withdraw (PWD) as regular products. See Legal Disclaimer and Warnings for further restrictions on Infineon Technologies warranty and liability.

European legislation in relation to inter alia the restriction of hazardous substances (RoHS), waste from electrical and electronic equipment (WEEE), electromagnetic compatibility, as well as duties to comply with CE, FCC or UL standards do not apply to the Evaluation Kit and the Evaluation Kit may not fulfill such requirements.

**LEGAL DISCLAIMER** THE INFORMATION GIVEN IN THIS DOCUMENT SHALL IN NO EVENT BE REGARDED AS A GUARANTEE OF CONDITIONS OR CHARACTERISTICS (“BESCHAFFENHEITSGARANTIE”). WITH RESPECT TO ANY EXAMPLES OR HINTS GIVEN HEREIN, ANY TYPICAL VALUES STATED HEREIN AND/OR ANY INFORMATION REGARDING THE APPLICATION OF THE EVALUATION KIT, INFINEON TECHNOLOGIES HEREBY DISCLAIMS ANY AND ALL WARRANTIES AND LIABILITIES OF ANY KIND, INCLUDING WITHOUT LIMITATION WARRANTIES OF NON-INFRINGEMENT OF INTELLECTUAL PROPERTY RIGHTS OF ANY THIRD PARTY.

**Information** For further information on technology, delivery terms and conditions and prices, please contact the nearest Infineon Technologies Office ([www.infineon.com](http://www.infineon.com)).

**Warnings** Due to technical requirements, components may contain dangerous substances. For information on the types in question, please contact the nearest Infineon Technologies Office. Infineon Technologies components may be used in life-support devices or systems only with the express written approval of Infineon Technologies, if a failure of such components can reasonably be expected to cause the failure of that life-support device or system or to affect the safety or effectiveness of that device or system. Life support devices or systems are intended to be implanted in the human body or to support and/or maintain and sustain and/or protect human life. If they fail, it is reasonable to assume that the health of the user or other persons may be endangered.

# Quickstart Guide for Inverter Evaluation Kit

## Inverter Evaluation Kit for HybridPACK™ Drive G2 Power Modules

### Introduction

### 1.2 Information Export Control Classification 3A225

Frequency changers (a.k.a. converters or inverters) and generators, that are usable as a variable frequency or fixed frequency motor drive and have all of the characteristics described below fall under the 3A225 classification.

**Table 1 Export control relevant performance data of the evaluation kit**

Question	Answer	Detailed Information
Multiphase output providing a power of 40VA or greater	YES	The inverter evaluation kit uses HybridPACK Drive G2 power modules, which can transfer power of several hundred kVA power. Typical application for this power module is 120 to 300kW traction inverters for electric vehicles.
Operating at a frequency of 600 Hz or more	YES	The evaluation kit does not limit the output frequency. Typical output frequency can be up to 0.1 times of the applied switching frequency. The evaluation kits are designed to operate with 10 up to 20kHz switching frequency (adjustable), which enables practical useable output frequencies of 2000 Hz easily.
Freqcy control better (less) than 0.2%	YES	The evaluation kit uses a digital control with Aurix™ Microcontroller. The Microcontroller clock is generated from a standard off-the-shelf crystal with a typical frequency tolerance of +/-15ppm at room temperature and additional +/-25ppm over the operating temperature.

### 1.3 Block Diagram

The following illustration show a simplified block diagram view of the inverter evaluation kit (shipping content) and the typical test bench setup.

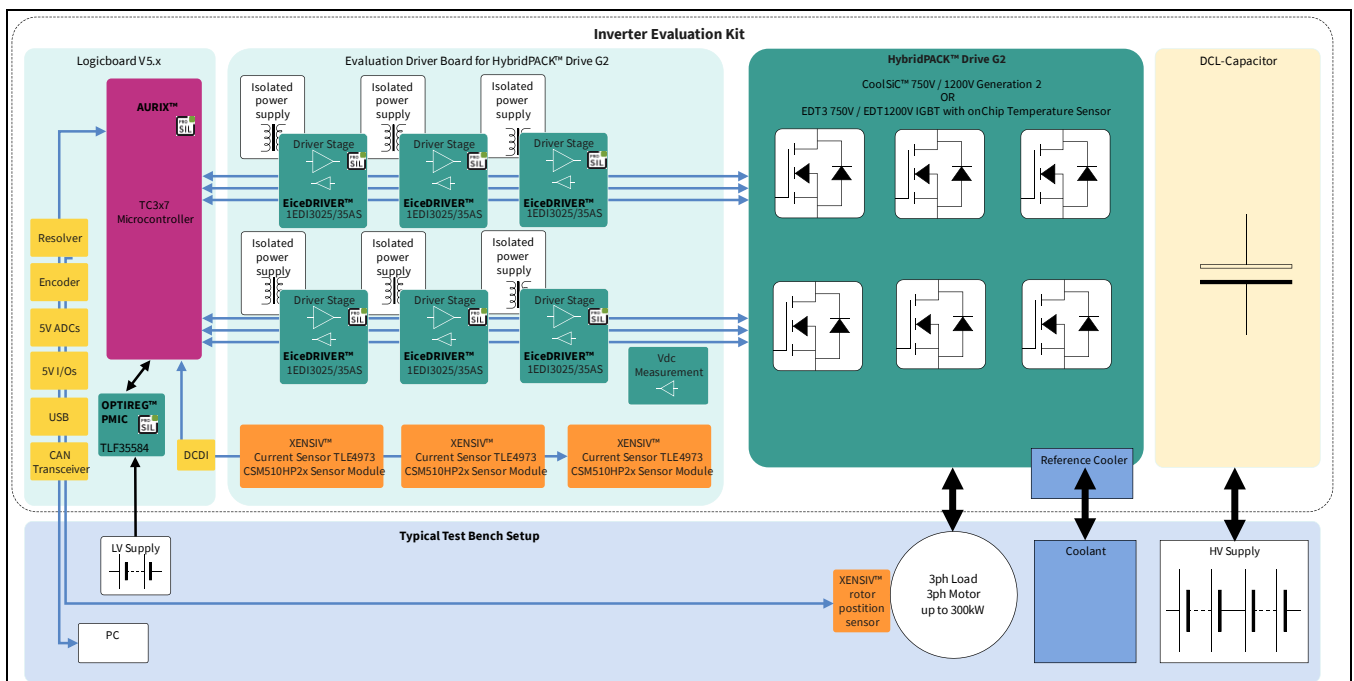

**Figure 1 Block Diagram of the Inverter Evaluation Kits for HybridPACK™ Drive G2 power modules**

## 2 Overview Evaluation Tools and Order Numbers

The inverter evaluation kits in Figure 2 comes with power module, cooler, DC-link capacitor, gate driver board, logicboard, pre-installed software, USB stick.

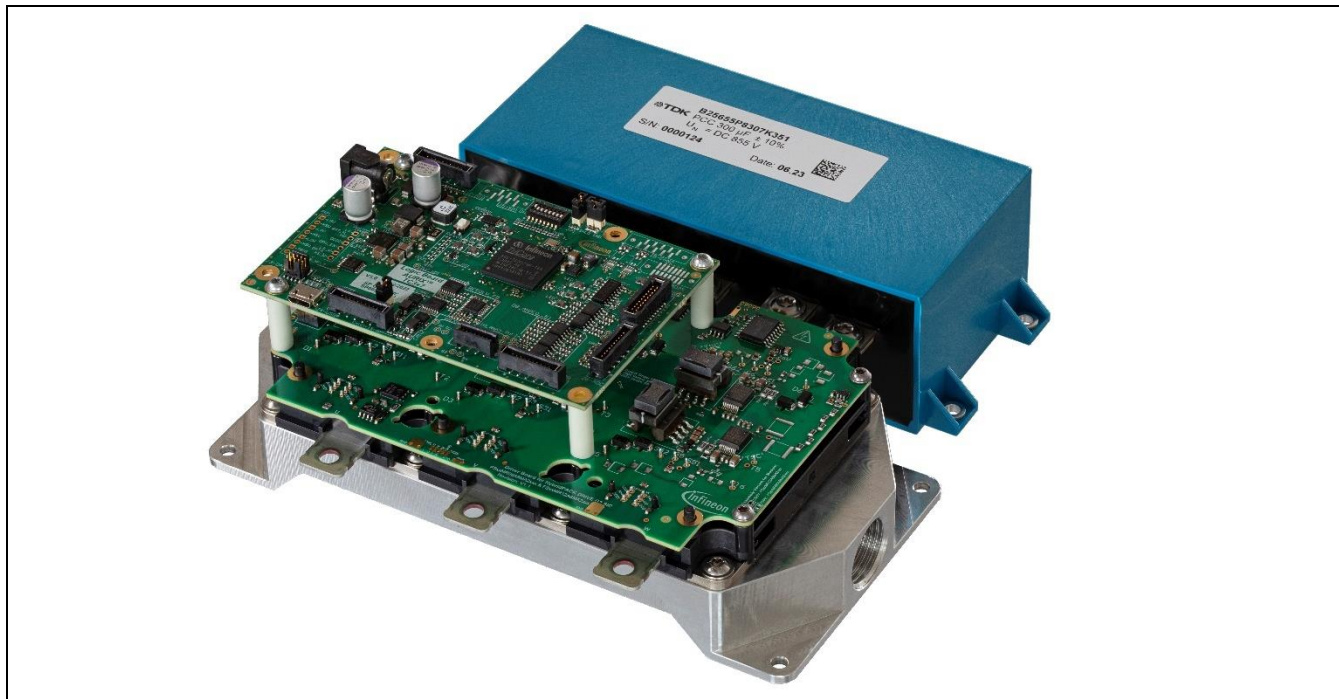

**Figure 2 Inverter Evaluation Kits for HybridPACK™ Drive G2 power modules. Versions with latest IGBT and SIC MOSFET chipsets at 750V and 1200V blocking capability are available. See also Table 2.**

**The inverter evaluation kits can be orderd at your local Infineon sales representative with the corresponding SP order number.** A comprehensive type designation tree for HybridPACK™ power module evaluation tools can be found in section 2.1.

**Table 2 Overview Inverter Evaluation Kits for HybridPACK™ Drive G2 power modules**

Type	Key Components	SP Order No	Order Name
Inverter Evaluation Kit with 750V/1150A IGBT power module	Power Module FS1150R08A8P3 Gate Driver Board with 1EDI3025AS CSM510HP2x Swoboda Phase Current Sensors Logicboard with Aurix 2G TC3x7	SP005739456	EV INV HPD2 SI FS1150 08
Inverter Evaluation Kit with 1200V/520A IGBT power module	Power Module FS520R12A8P1 Gate Driver Board with 1EDI3025AS CSM510HP2x Swoboda Phase Current Sensors Logicboard with Aurix 2G TC3x7	SP006038374  Obsolete No SP005739466	EV INV HPD2 SI FS520 12
Inverter Evaluation Kit with 750V/1 mOhm SIC MOSFET power module	Power Module FS01MR08A8MA2 Gate Driver Board with 1EDI3035AS CSM510HP2x Swoboda Phase Current Sensors Logicboard with Aurix 2G TC3x7	SP005739468	EV INV HPD2 SIC FS01 08
Inverter Evaluation Kit with 1200V/2 mOhm SIC MOSFET power module	Power Module FS02MR12A8MA2 Gate Driver Board with 1EDI3035AS CSM510HP2x Swoboda Phase Current Sensors Logicboard with Aurix 2G TC3x7	SP006056146  Obsolete No <sup>1</sup> SP005739445	EV INV HPD2 SIC FS02 12

<sup>1</sup> In order to follow the type designation tree, several order numbers were revised. In case of re-orders please use the latest numbers.

# Quickstart Guide for Inverter Evaluation Kit

## Inverter Evaluation Kit for HybridPACK™ Drive G2 Power Modules

### Overview Evaluation Tools and Order Numbers

## 2.1 Type designation tree for evaluation tools

The product order names of the evaluation tools were changed in Jan 2024 in order to support a comprehensive type designation tree for the available evaluation tools. The structure of the new naming is shown in the figure followed by some examples.

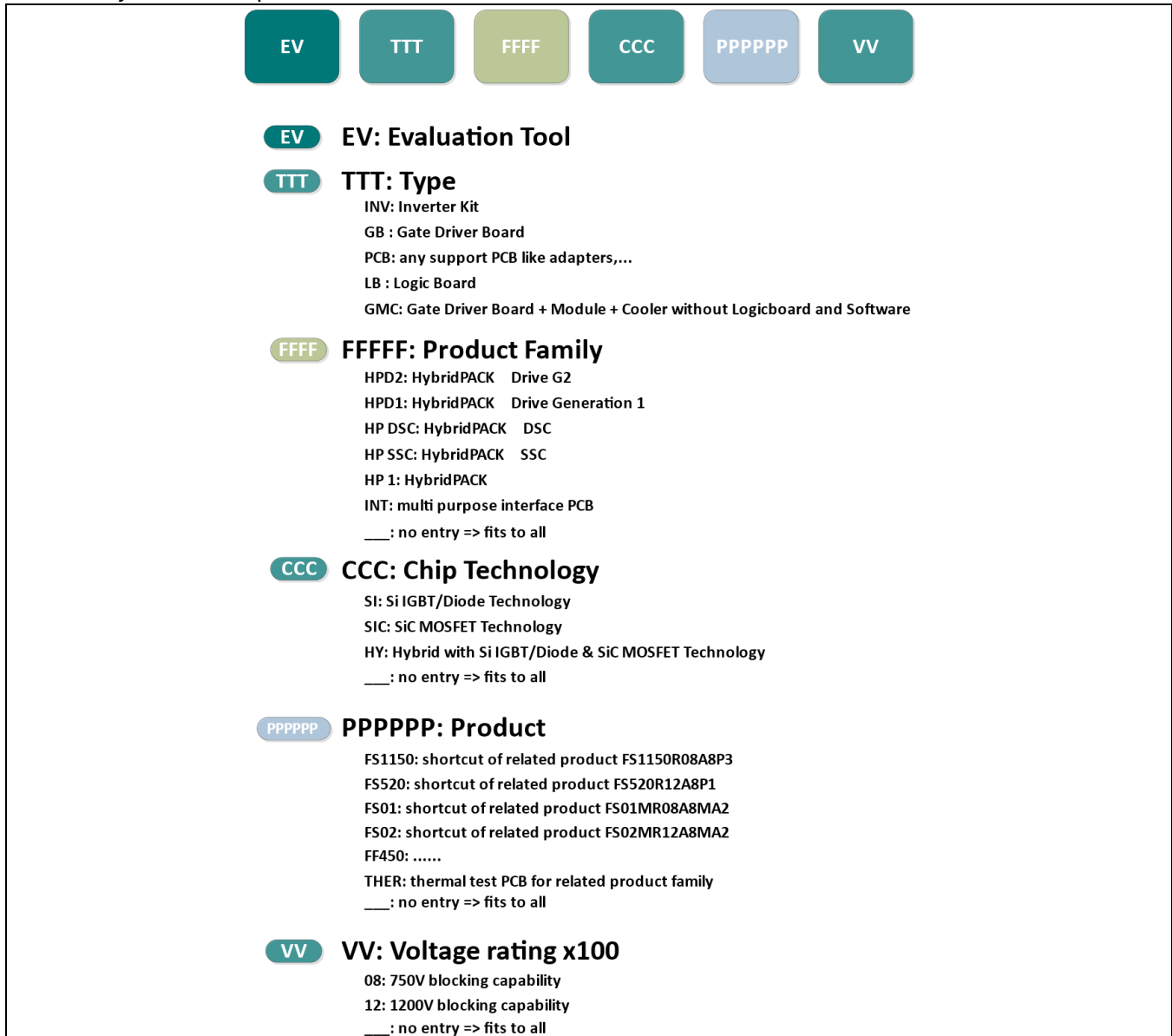

Figure 3 Type designation tree for the HybridPACK™ power module evaluation tools.

Some Examples:

**EV INV HPD2 SI FS520 12:** Inverter Evaluation Kit for HybridPACK™ Drive G2 Si 1200V Automotive Power Module FS520R12A7P1 and Swoboda Phase Current Sensor.

**EV INV HPD2 SIC FS02 12:** Inverter Evaluation Kit for HybridPACK™ Drive G2 SiC 1200V Automotive Power Module FS02MR12A8MA2 and Swoboda Phase Current Sensor.

**EV GB HPD2 SIC:** Evaluation Kit - Gate Drive board for HybridPACK™ Drive G2 750V & 1200V SIC power module with 1EDI3035AS gate driver.

**EV GB HPD2 SI 08:** Evaluation Kit - Gate Drive board for HybridPACK™ Drive G2 750V IGBT power module with 1EDI3025AS gate driver.

**Overview Evaluation Tools and Order Numbers**

**2.2 Recommended Lab Equipment**

For evaluation following lab equipment is recommended:

- Low voltage power supply (within the shipping box or 14V, 2A supply).
- CAN card. Recommended “Peak CAN USB” (PCAN USB opto) [3].
- High Voltage power supply (see section 2.3)
- Oscilloscope & Current Probes depending on loads

**2.3 Recommended Operating Conditions**

The following recommended operating conditions describe the targeted lab testing environment.

Testing beyond the given area may be possible in specific cases when all individual parts are driven within their specification. On the other hand, the evaluation kit with logic, gate driver board together with the power module should not be regarded as a protected system. It is not a considered product for end customers. The intention of the evaluation kit is to support engineers in their first steps designing with the Infineon HybridPACK™ Drive G2 power module, EiceDriver™ gate drivers, Xensiv™ current sensor. Please see also the section 1.1 & 2.4 in order to understand the limitations.

**Table 3 Operating Conditions**

Type	Symb	Min	Typ	Max	Conditions
12V Logic Board Supply	12V_IN_LV	10 V	12 V 14 V	18 V	Power supply has to deliver up to 25W. Isolated power supply recommended to avoid GND loops with measurement equipment
HV Working Voltage (Capacitor DC-Link Voltage)	VDClk_HV	0 V		500 V (for 750 V chipsets)  850 V (for 1200 V chipsets)	For double pulse tests <250mA  For inductive dummy loads typ up to 30kW (depending on load tests)  For inverter operation up to 300kW (depending on load tests)
Interfaces Logicboard and Gate Driver Board	V <sub>interfaces</sub>	0 V	0..5 V	5 V	All interfaces like PWM, Enable, Sensor output, etc is 5V logic. Apply higher voltages only to pins which are specified explicitly other.
Ambient Temperature	T <sub>amb</sub>	-40°C		85°C	>65°C not recommended
Coolant Fluid Temperature	T <sub>F</sub>	-40°C		85°C	Typical flowrate 10L/min with 50%/50% Water/Ethylenglycol
Switching frequency	f <sub>sw</sub>		10 kHz	20 kHz	For short term operation >20kHz might be possible. Please apply appropriate cooling to the gate driver boards.

## **2.4 Limitations of the Evaluation Kit**

The inverter evaluation kit was designed with some basic shutdown routines but due to the free parameter setting and undefined lab setup and environment it should not be regarded as a protected system. Most of the protection features can be disabled by the user (e.g. set limit to 1000°C instead of 175°C), which makes tests also under extreme abnormal conditions possible. The evaluation kit is not protected against:

- Over- & undervoltages on the signal connectors.
- Overvoltages of the 12V Board Supply voltage.
- Overvoltages of the HV working voltage.
- Overtemperature of the PCB and module (e.g. operation will not stop without coolant fluid where  $T_{vj}=175^{\circ}\text{C}$  can lead to damage of the power module).
- Testing at high switching frequencies may require an active cooling of the gate driver board especially at high ambient temperatures.
- For short circuit testing please see [2] for more detailed information.

Please note that the above list is giving examples and should not be seen exhaustive.

# Quickstart Guide for Inverter Evaluation Kit

## Inverter Evaluation Kit for HybridPACK™ Drive G2 Power Modules

### Interface Descriptions

## 3 Interface Descriptions

### 3.1 Interfaces Logic Board

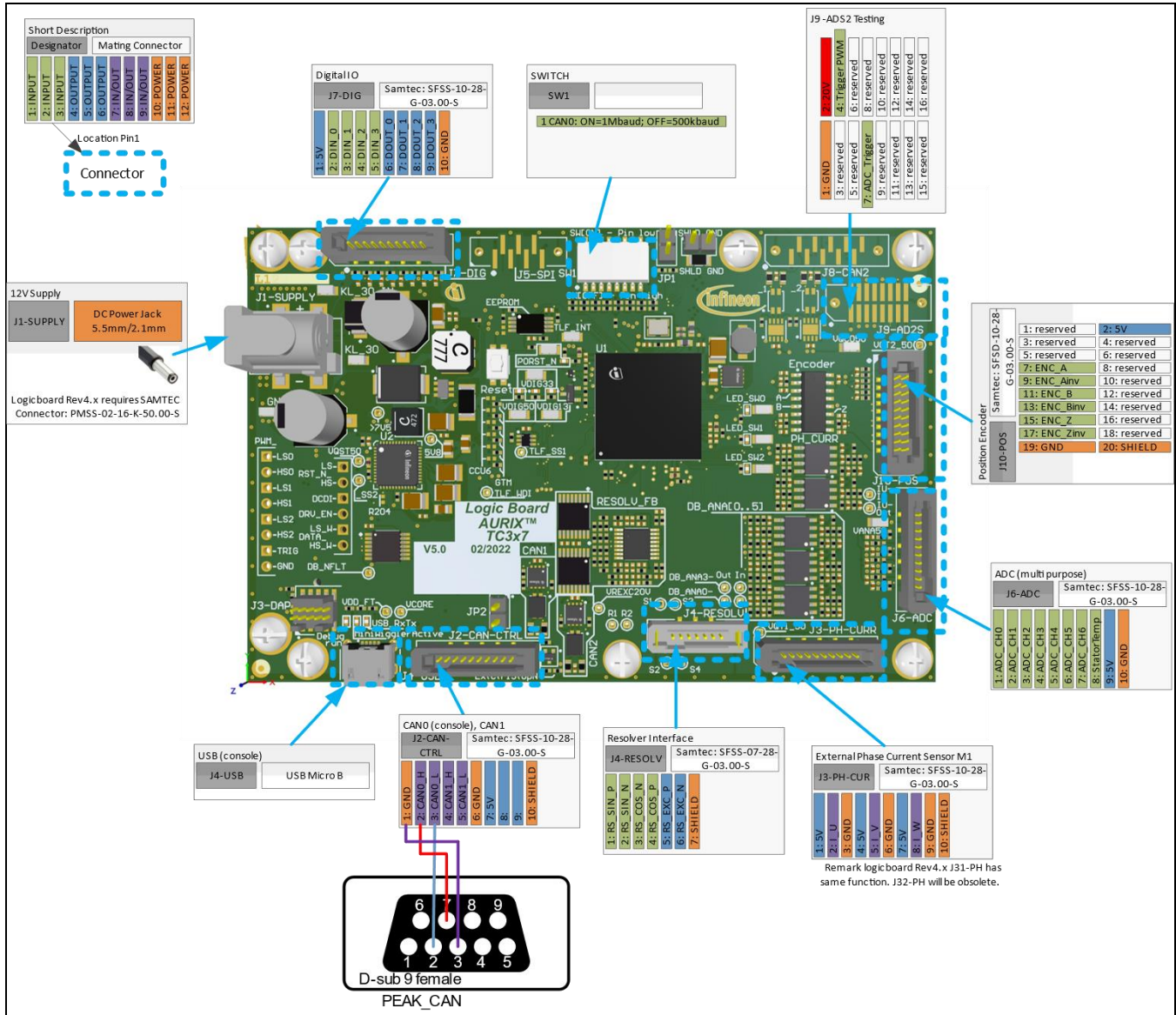

Figure 4 Connectors of Logicboard LB5.x.

# Quickstart Guide for Inverter Evaluation Kit

## Inverter Evaluation Kit for HybridPACK™ Drive G2 Power Modules

### Interface Descriptions

### 3.2 Interfaces Gate Driver Boards (IGBT Versions)

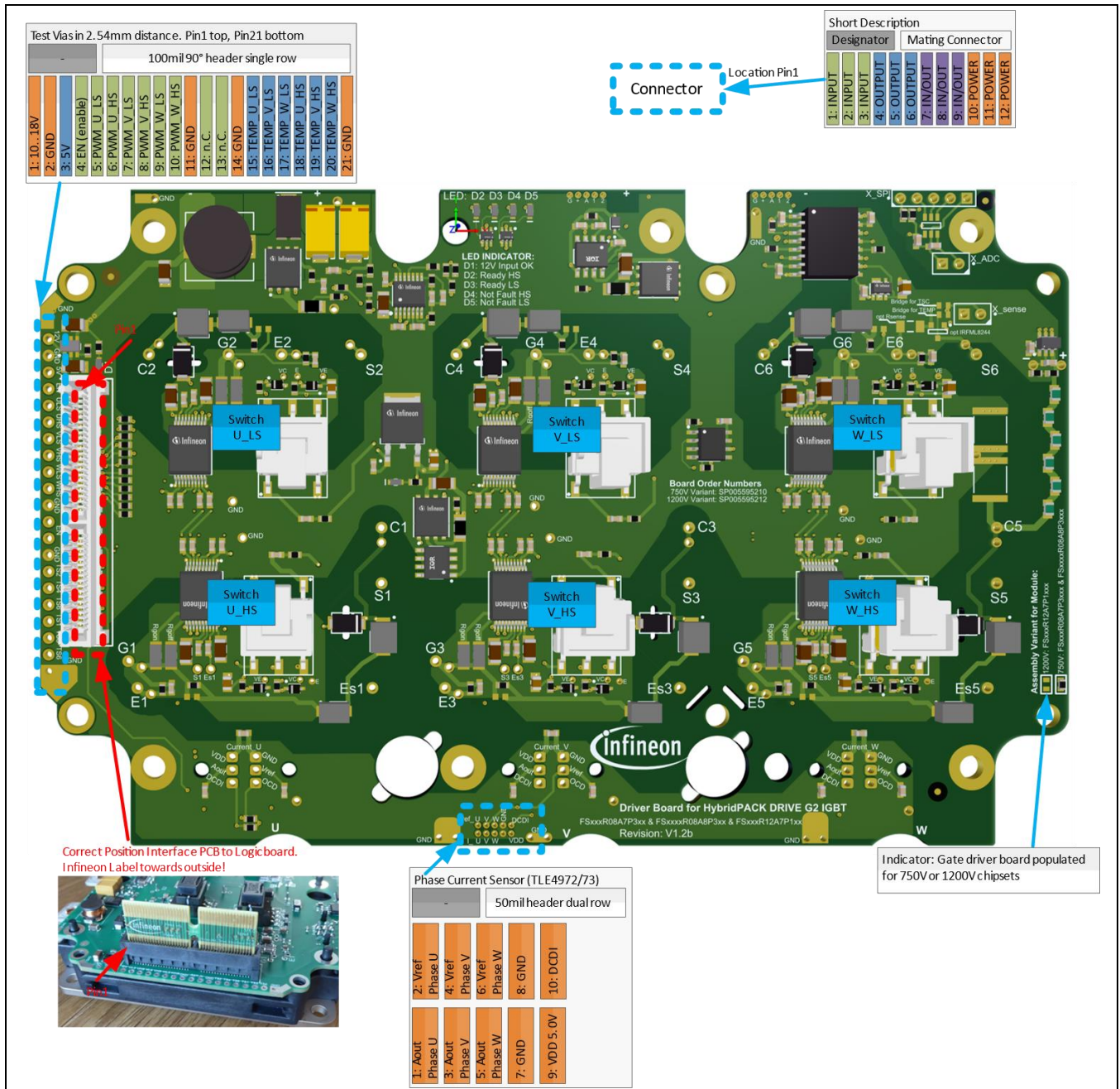

Figure 5 Connectors of Gate Driver Boards (IGBT Versions).

# Quickstart Guide for Inverter Evaluation Kit

## Inverter Evaluation Kit for HybridPACK™ Drive G2 Power Modules

### Interface Descriptions

### 3.3 Interfaces Gate Driver Boards (SIC MOSFET Versions)

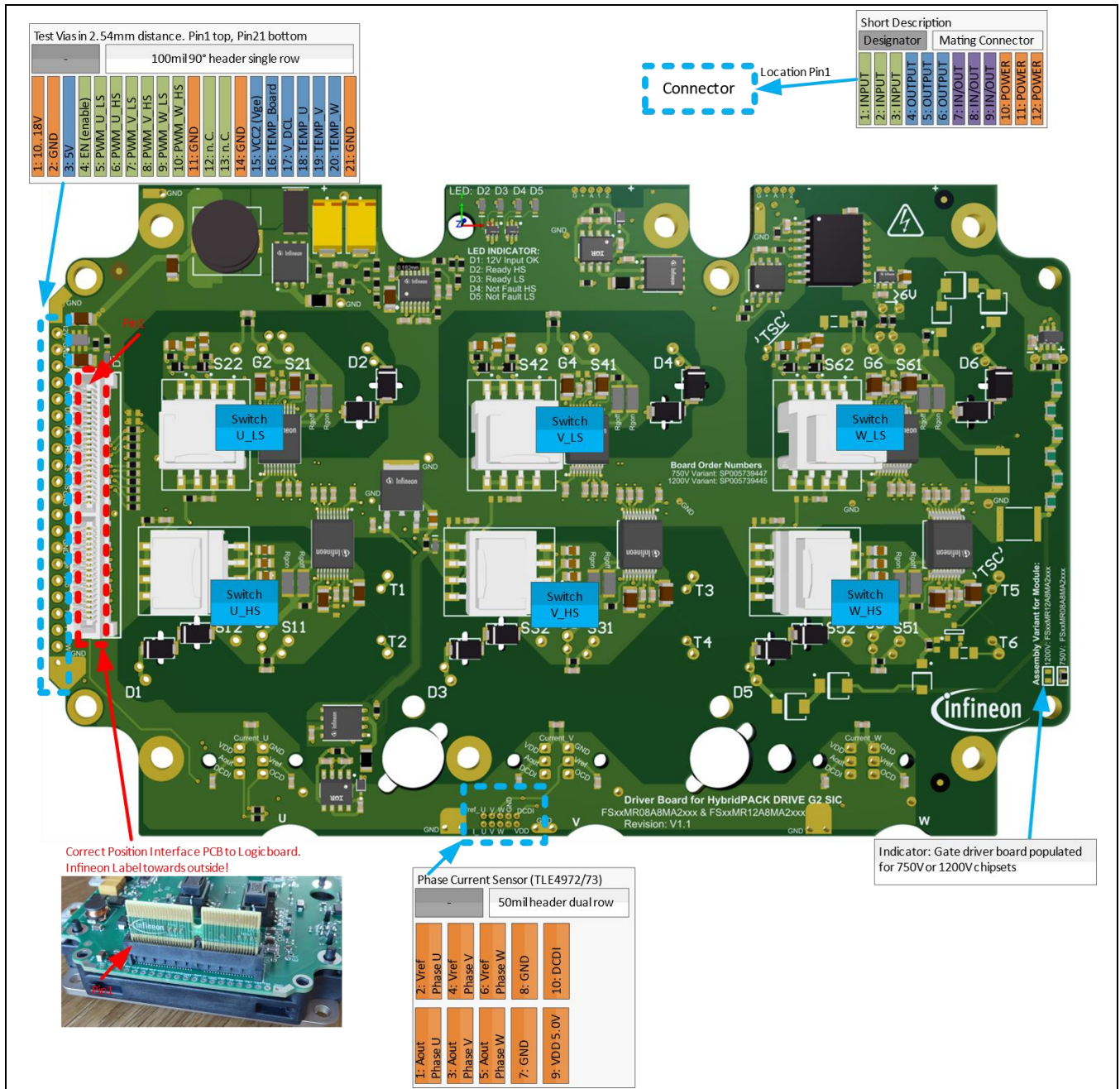

Figure 6 Connectors of Gate Driver Boards (SIC MOSFET Versions).

# Quickstart Guide for Inverter Evaluation Kit

## Inverter Evaluation Kit for HybridPACK™ Drive G2 Power Modules

### Quickstart Guide

## 4 Quickstart Guide

This chapter provide a basic introduction of the most common use cases of lab testing. Please note that this evaluation kit is able to operate under high voltages and high currents and power electronics experienced staff is required for testing such parts.

### 4.1 Typical Setup for Inverter Load Tests

The typical setup for inverter load tests is shown in Figure 7. For light load tests and test with mainly reactive power, the DC supply is normally sufficient via the two center DC tabs only. The USB connection is recommended to be disconnected for load tests.

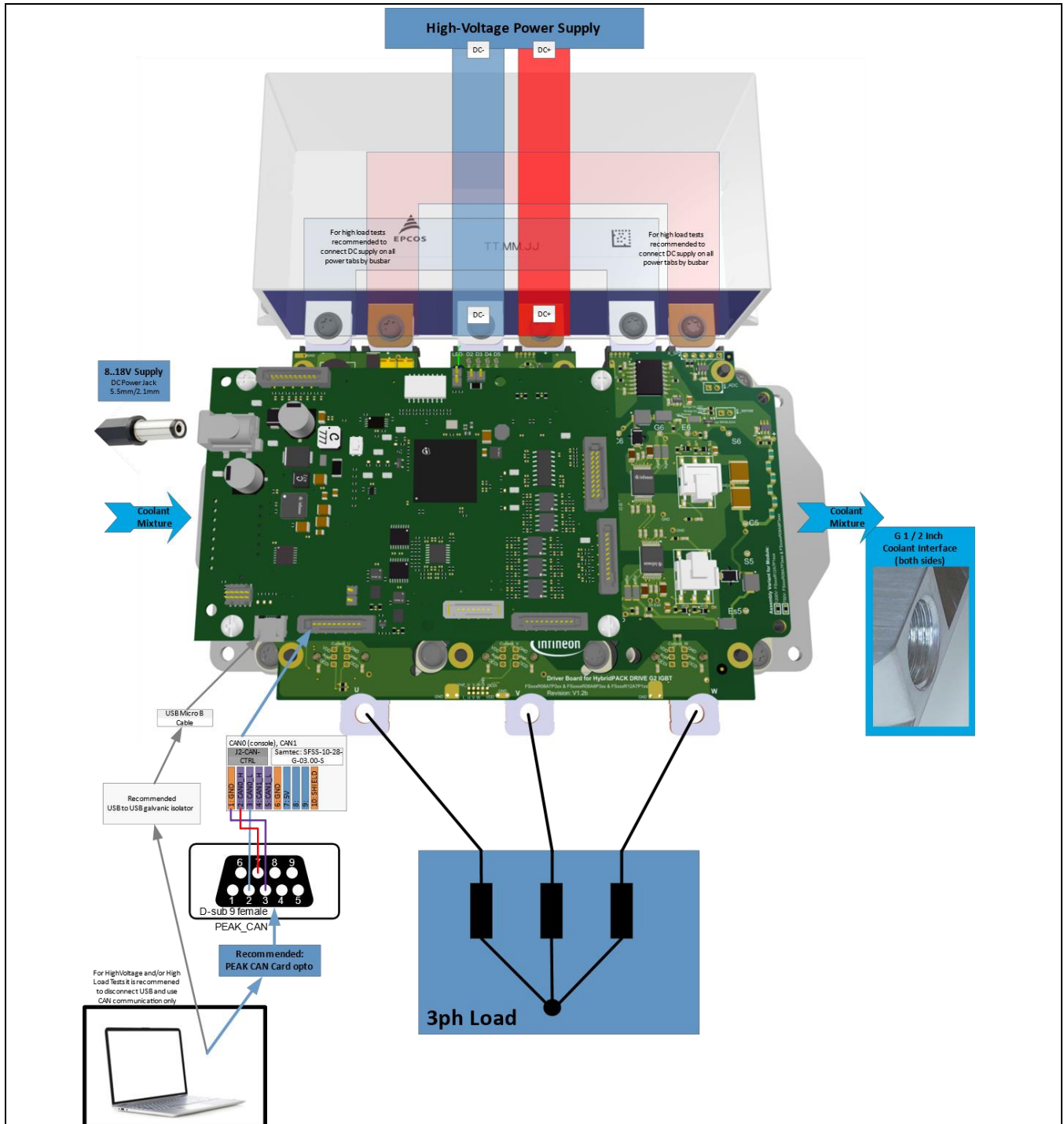

Figure 7 Typical setup for Inverter Load Tests.

# Quickstart Guide for Inverter Evaluation Kit

## Inverter Evaluation Kit for HybridPACK™ Drive G2 Power Modules

### Quickstart Guide

## 4.2 DEMO Mode (Inverter Operation without Communication)

For enabling the DEMO-MODE following conditions are required:

- 1) Turn-off all supplies.
- 2) Connect supplies to the inverter evaluation kit (see section 4.1).
- 3) Place DEMO-ENABLE-PLUG (see Figure 8).
- 4) Place DEMO-CONTROL-PLUG (see Figure 8).
- 5) Turn potentiometers for modulation index and output frequency to low position. (i.e. pin 1 & pin2 are connected to GND; see Figure 8)
- 6) Turn-on logic board supply (8..18V). Within the next 3 seconds the inverter starts the operation.
- 7) Turn-on high voltage supply (respect the limits of the evaluation kit).
- 8) **The inverter is fully operating and can now be controlled by the pots or external analog 0...5V signals (modulation index and output frequency).**

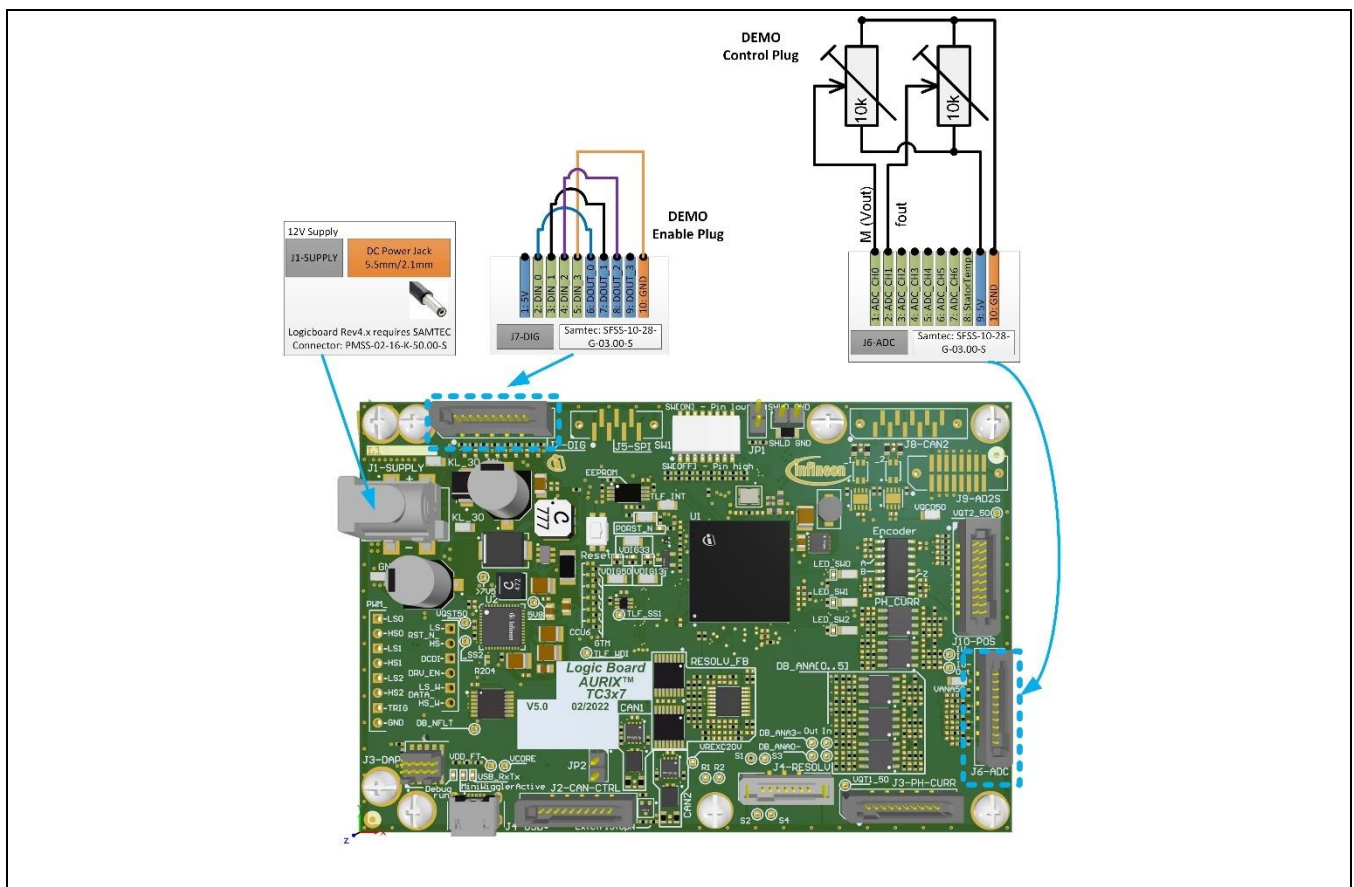

**Figure 8 Connection to enable the DEMO-MODE in order to operate the inverter kit without communication in open loop operation.**

Only the modulation index and the output frequency can be adjusted in the DEMO-MODE. All other parameters, like switching frequency, dead times, gate driver setting, etc. are set to pre-defined default values from the evaluation kit software. Thus, it should be clear that such default values should not be regarded as optimized parameters, but can be used as a system design starting point and would be compatible to most load and operating conditions.

The parameter values can be configured and non-volatile stored by usage of graphical user interface with ONEEYE tool and USB or CAN bus communication (see section 5.1).

**Quickstart Guide**

**4.2.1 DEMO Mode: Adjusting the Modulation Index**

The modulation index can be adjusted by the analog 0..5V signal on pin 1 on the DEMO-CONTROL-PLUG. At the beginning this signal must be low, otherwise the PWM will not be enabled. Then the signal can be adjusted between 0 and 5V and the modulation index of the space vector modulation follows linear from 0% and 100%. In order to ensure a smooth operation a simple ramp-up and ramp-down function is implemented as it can be seen in Figure 9.

At Figure 9 time 0ms the modulation set value is adjusted rapidly from 0V to 5V. The internal ramp function limits the speed and controls the modulation index within 4 seconds from 0% to 100%. In the zoom pictures the resulting phase to phase output voltage at 400V dc working voltage can be seen. At about 3.5 seconds it can be seen, that the space vector modulation comes in the so called overmodulation range resulting in a slight trapezoidal waveform. Not shown but similar would be a ramp down event.

In summary, the operator can adjust the phase to phase output voltage by the modulation index within the limits of the applied working voltage (i.e. DC-Link voltage). By adjusting the output voltage, the currents are also changed depending on the impedance of the load.

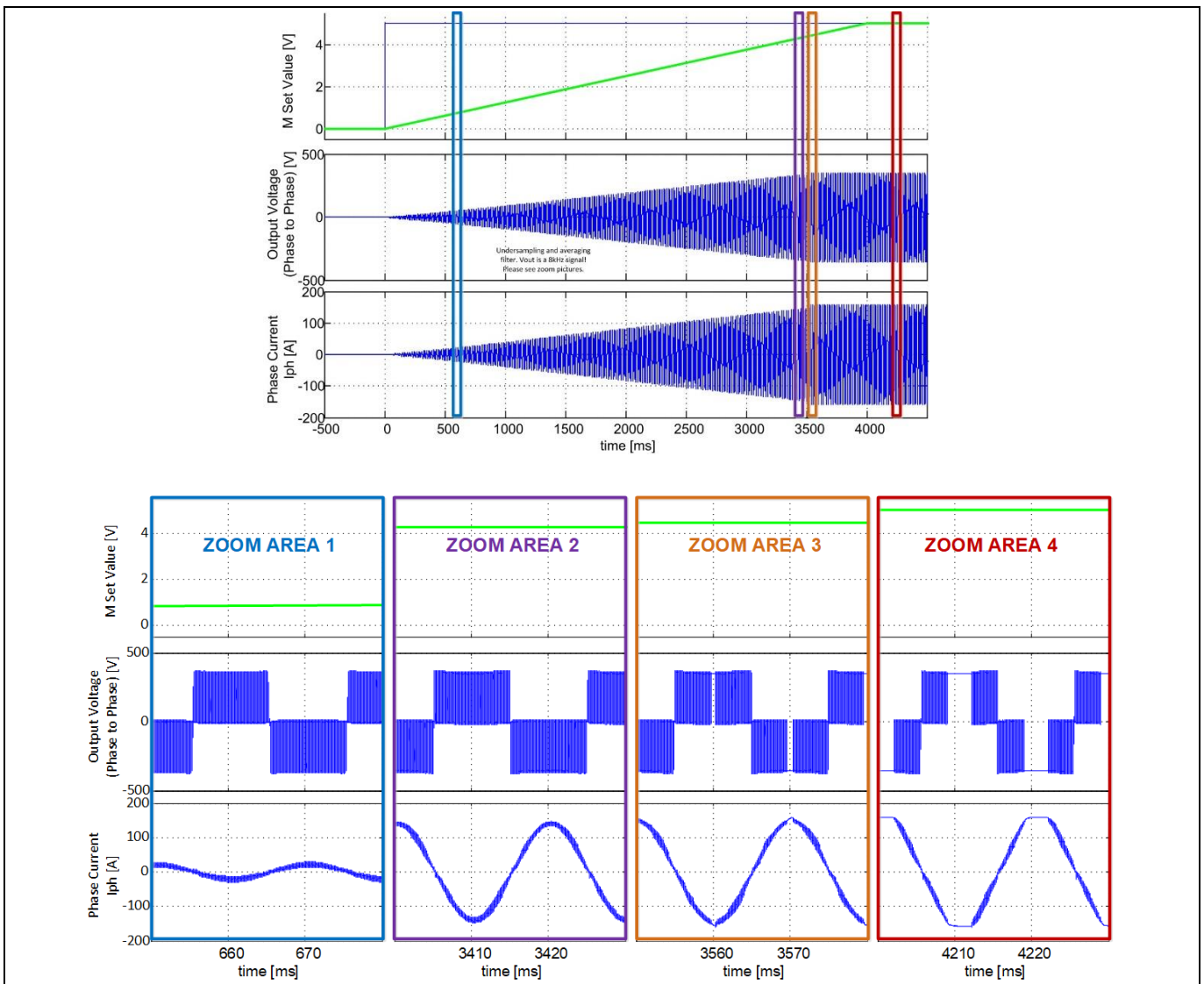
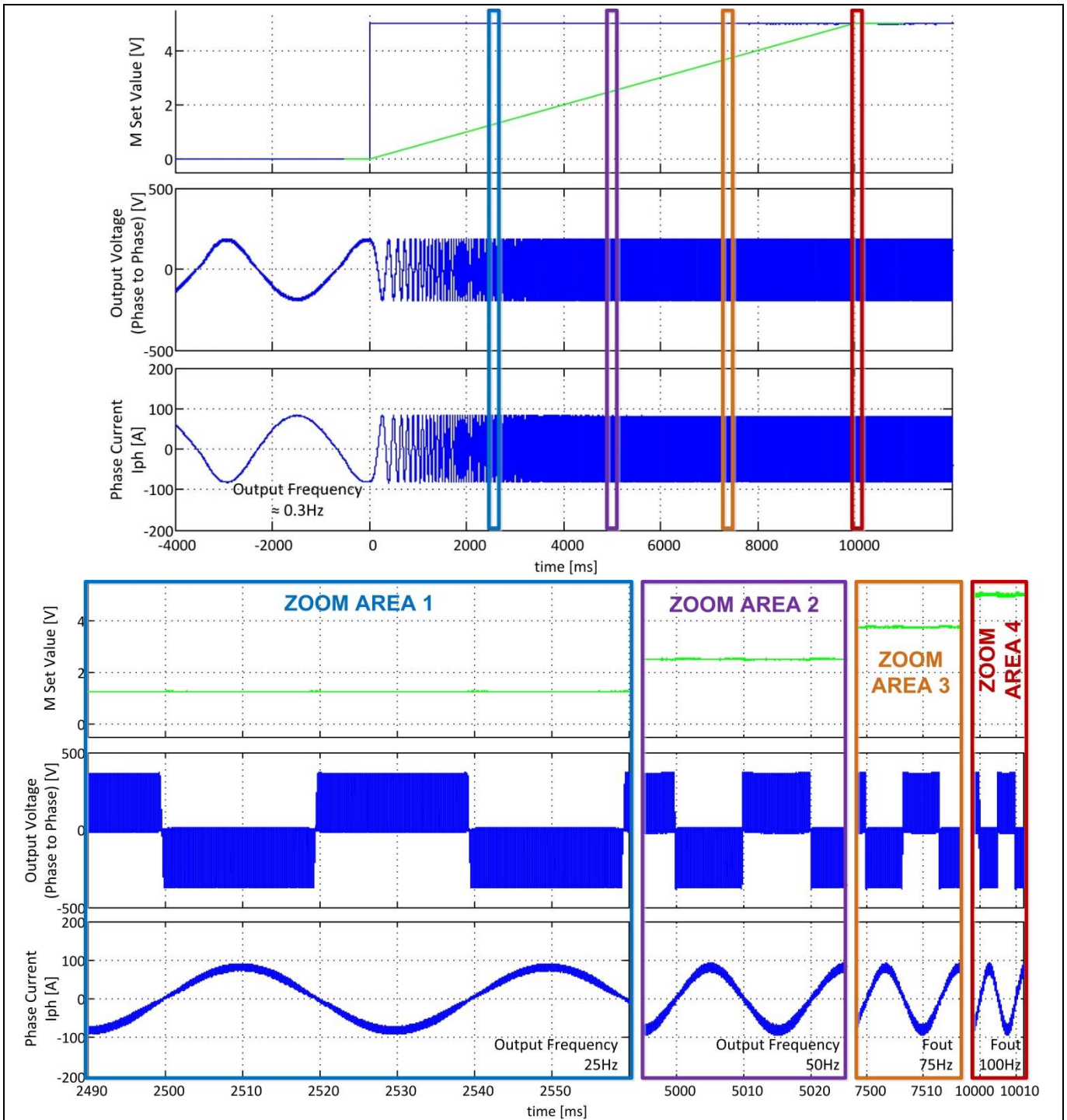

**Figure 9 Measured event, where operator changes the modulation set value rapidly from 0V to 5V. The internal ramp function ensures a smooth transition from 0% to 100% modulation index. The modulated phase to phase output voltage is consequently increased within the limits of the applied system working voltage.**

**Quickstart Guide**

**4.2.2 DEMO Mode: Adjusting the Output Frequency**

The output frequency can be adjusted in similar way as the modulation index. A real example is shown in Figure 10. The 0..5V voltage signal on pin 2 of the DEMO-CONTROL-PLUG sets the output frequency to the load. A ramp function also ensure a smooth transition when a new setpoint is applied (see smooth actual f<sub>out</sub> value in green). The frequency is ramped within 10 seconds from nearly 0Hz to 100Hz, which are the pre-defined standard values in the software.



**Figure 10 Measured event, where operator changes the output frequency set value rapidly from 0V to 5V. The internal ramp function ensures a smooth transition from nearly 0Hz to 100Hz output.**

### Quickstart Guide

## 4.3 Inverter Tests (Introduction Open Loop mode)

The easiest way to start with the 1<sup>st</sup> tests requires:

- Latest OneEye Tool (can be downloaded from the Infineon website under the developer center launcher application)
- OneEye GUI configuration file for the inverter evaluation kit (see USB stick of the shipping content)
- Power supply (8..18V) for the logicboard
- Peak CAN card recommended (USB does not support to monitor the status of the evaluation kit)

If CAN connection is ready, it is very simple to start inverter open loop operation. Please see Figure 12 where the relevant sequence is indicated. After booting the evalkit, the device is in configuration mode.

1. You can exit the configuration status by clicking **Exit Configuration**. The status page already shows the measured values.
2. Select now the **Open Loop Mode**
3. You can now click the **Run** button
4. Finally, you can adjust the **Amplitude** (Modulation Index) and the **Speed** (in rpm or in Hz output frequency)

The GUI bring a basic CAN datalogger as well as a software scope function. With the software scope function, it is possible to measure the most relevant parameters synchronous to the PWM pattern. The data can be saved also

# Quickstart Guide for Inverter Evaluation Kit

## Inverter Evaluation Kit for HybridPACK™ Drive G2 Power Modules

### Quickstart Guide

## 4.4 Inverter Kit Parameter Adjustment

The OneEye GUI brings already a very convenient tool for adjusting parameters of the evaluation kit. Parameters can be read at any time. Please note that most parameters can be adjusted any time but save to ECU is only possible in configuration mode (entered after BOOT, or stop operation and click shutdown and save than the parameters). After the next startup the new parameters will be used for the operation.

You can easily adjust the PWM frequency, deadtime, overvoltage shutdown level, sensor gains etc. Please note that the part is for evaluation purpose only. The SW will not check if the applied parameters can damage the evaluation kit. It was explicitly designed with minimum protection mechanism in order to make it possible to test the devices to their limits or even beyond their limits.

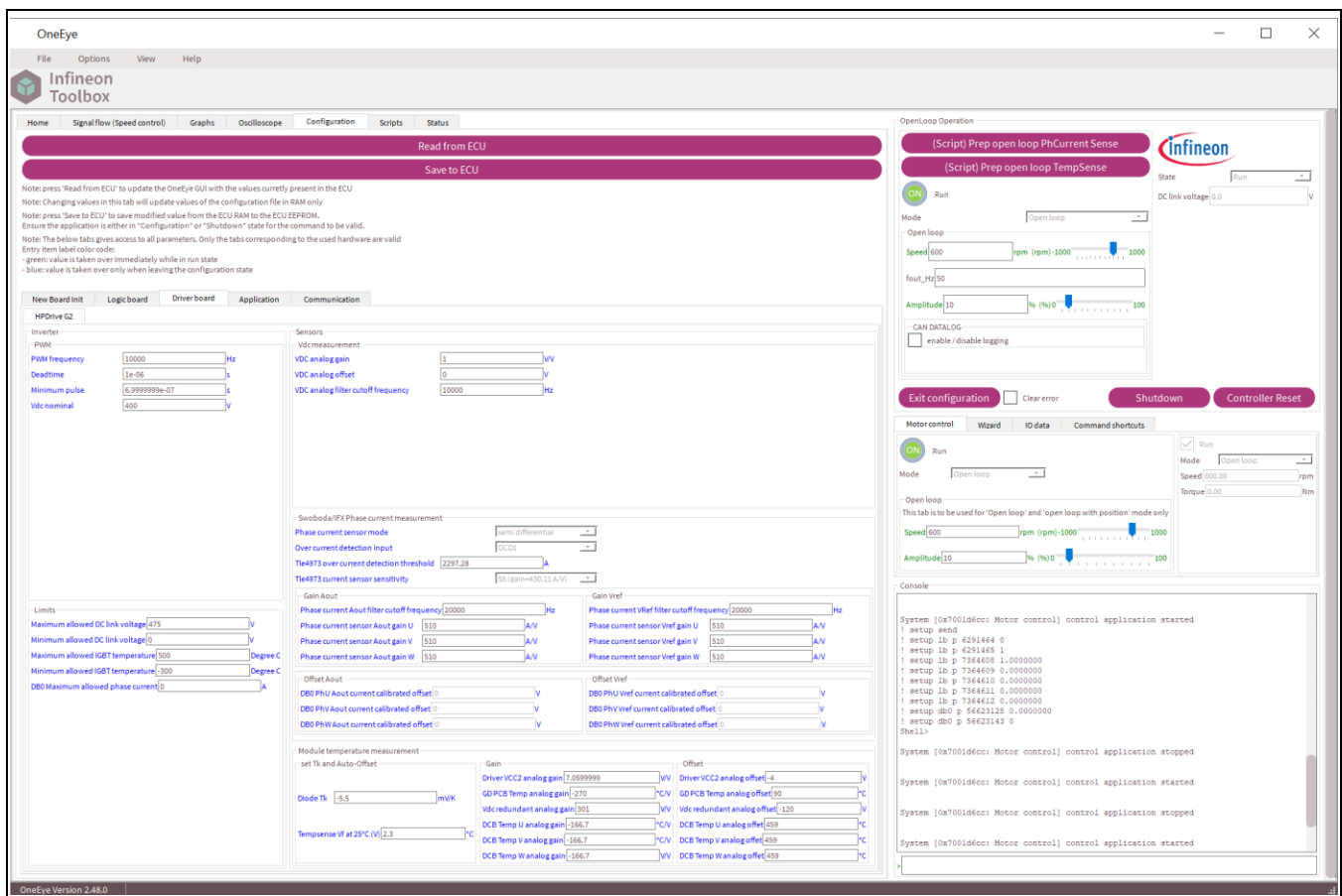

Figure 11 OneEye GUI for adjusting parameters of the evaluation kit.

# Quickstart Guide for Inverter Evaluation Kit

## Inverter Evaluation Kit for HybridPACK™ Drive G2 Power Modules

### Quickstart Guide

#### 4.5 Information for Calibration of Phase Current Sensors

The integrated sensors in the driver board can be calibrated. The most practical way for calibration is with a DC current source connected with the polarity as shown in the example. The current will flow over the power module freewheeling diodes which can be done for some seconds without cooling the power module. If the reference sensor does not match to the current sensor readout from the evaluation kit the gain parameter can be adjusted in the OneEYE GUI under Configuration/DriverBoard. Do not forget to save the values. The same principle can be applied to the other phases

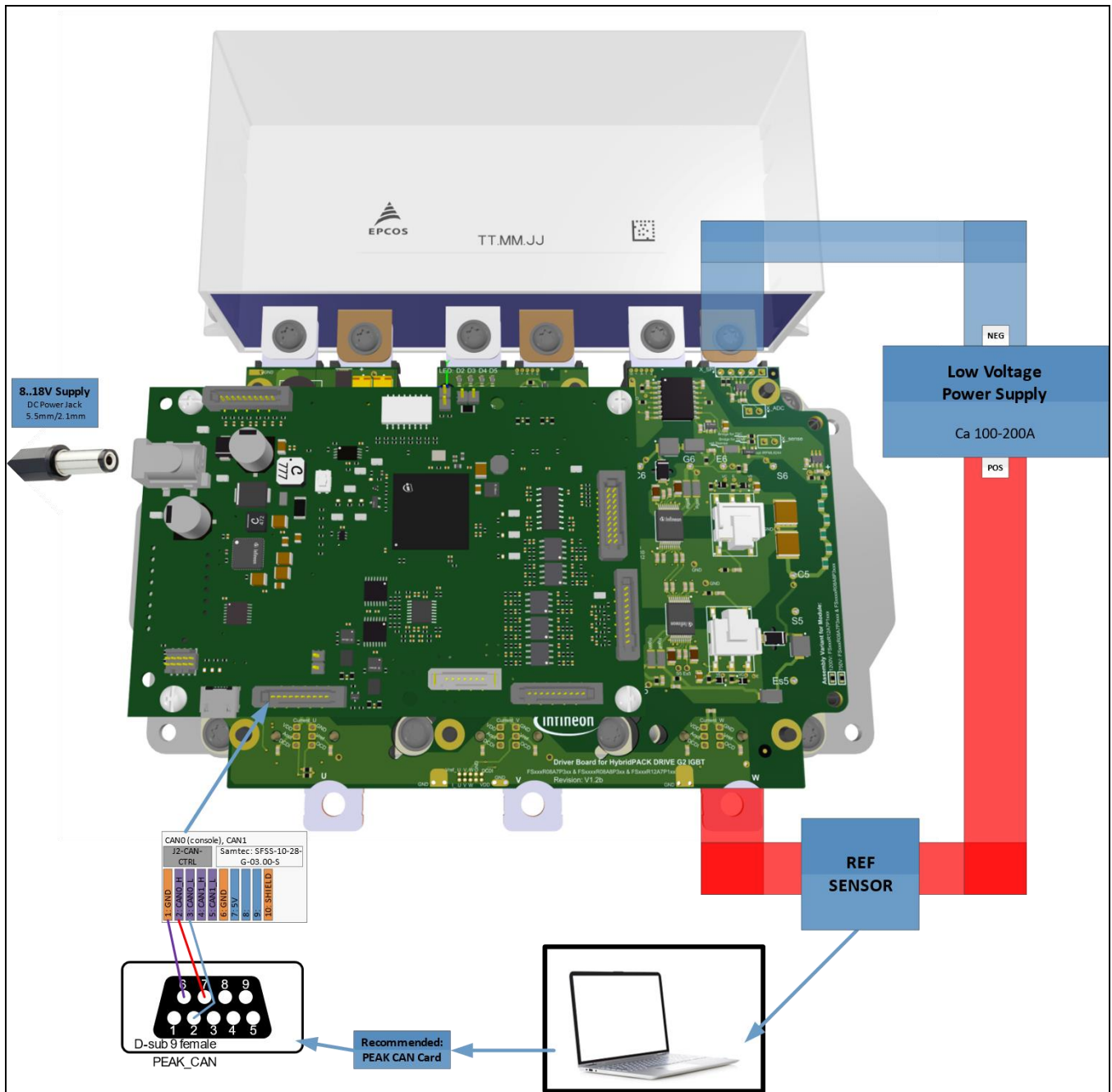

Figure 12 Setup for Gain Parameter Calibration of the Current Sensors (shown only example for phase W).

## **5 Trouble Shooting and further detailed Information**

In case of problems we recommend to use communication to see the SHELL report if any errors are reported by the inverter kit. A next step can be flashing new software and apply initial parameters again. The information for these steps can be found in the following sections.

### **5.1 Communication with the Evaluation Kit**

The inverter evaluation kit has two options for the communication: and USB serial communication and CAN bus communication. In case of operation under high voltage it is highly recommended to use isolated communication (like opto isolated CAN card or opto isolated USB/USB connectors). For operation under high load and high voltages it is known that USB serial connection might fail. CAN bus communication is always the more stable and recommended option.

#### **5.1.1 USB serial Communication**

The evaluation kit logicboard can be connected by USB mini cable to the PC. Please ensure that the virtual COM port drivers of the FDTI chipset is installed at your computer. The FDTI drivers will be automatically installed with the Infineon MEMTool. Latest drivers or in case of problems the device drivers can be installed from the manufacturer website: <https://ftdichip.com/drivers/vcp-drivers/>

After physical connection and power up the logicboard the connection can be established by the Infineon ONEEYE tool (see GUI file prepared for USB) or any available shell program like Tera Term, Putty, etc.

- Port: Typically the COM port with the highest number
- Speed: 115200 kbaud
- Data: 8 bit
- Parity: none
- Stop bits: 1 bit
- Flow control: none
- New-line Receive: CR+LF
- New-line Transmit: CR+LF
- Coding: UTF-8

**Trouble Shooting Hint 1:** In case of connection problems look at the device manager of your PC operating system. Check if the virtual COM port appears without error indication and reinstall the device drivers if not.

**Trouble Shooting Hint 2:** Look in ONEEYE Tool under Configuration/Communication. Select COM port and reconnect. Power cycle the board and check if SHELL is reporting a communication.

#### **5.1.2 CAN bus Communication**

The recommended communication with the evaluation kit logicboard is via CAN bus communication. The evalkit communication was tested with PEAK CAN cards but others might work too. The correct wiring can be seen in Figure 4. Please ensure that appropriate device drivers are installed at your PC operating system. <https://www.peak-system.com/>

After physical connection and power up the logicboard the connection can be established by the Infineon ONEEYE tool (using GUI prepared for CAN). If other than ONEEYE tool is used, the CAN Message catalog can be found in section 5.4.

# Quickstart Guide for Inverter Evaluation Kit

## Inverter Evaluation Kit for HybridPACK™ Drive G2 Power Modules

---



### Trouble Shooting and further detailed Information

**Trouble Shooting Hint 1:** In case of connection problems look at the device manager of your PC operating system. Check if the CAN card is detected and operating.

**Trouble Shooting Hint 2:** Look in ONEEYE Tool under Configuration/Communication. Check if CAN card is detected and correct baud rate is set. Please check the DIP switch 1 (see Figure 4) if it matches to the communication baud rate. Click reconnect. Power cycle the board and check if SHELL is reporting a communication.

**Trouble Shooting Hint 3:** If CAN communication still fails. Try to connect via USB serial communication and check if Logicboard and Software still running.

# Quickstart Guide for Inverter Evaluation Kit

## Inverter Evaluation Kit for HybridPACK™ Drive G2 Power Modules

### Trouble Shooting and further detailed Information

## 5.2 Software flashing into Logicboards via Memtool

For flashing a compiled software (.hex) file into the Logicboards you need:

- Latest Memtool on the PC (download from the Infineon website)
- Power supply (8..18V) for the logicboard
- USB mini cable from Logicboard to the PC

For 1<sup>st</sup> time use you need to set the correct Microcontroller (target device). A configuration file can be found in the folders of USB stick, which is part of the shipping content of the inverter evaluation kits. After Memtool start please click on Target / Change ... . Copy the configuration file into the folder to browse and select the LB 5.x (Memtool\_LB5x.cfg) file. See Figure 13 for a short example how to set the target device.

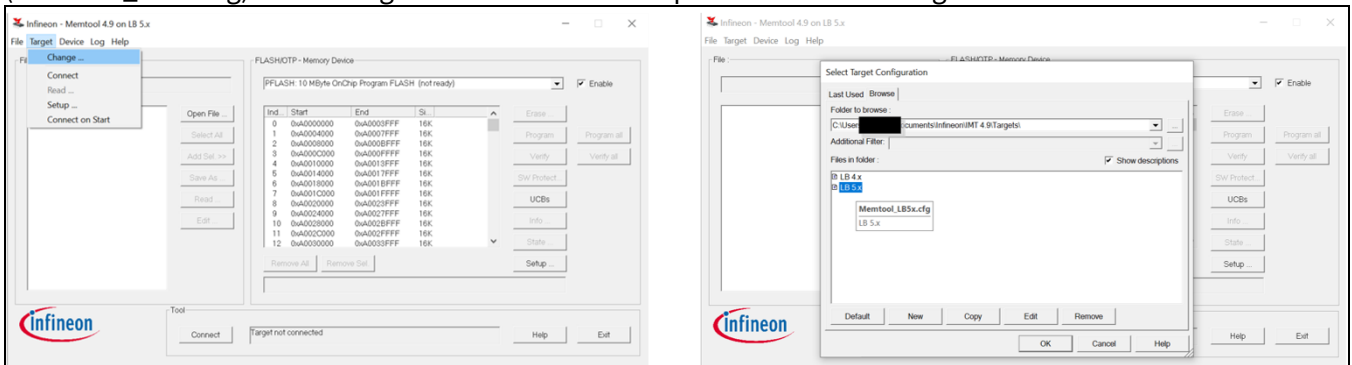

**Figure 13 Prepare Memtool for the Target Device.**

Once you have set the correct target device please click first on connect. If the status message appear as shown in the Figure 14 “Ready for Memtool Command” please continue with.

- 2) Open File.. (select the .hex file in the popup dialog)
- 3) Select All
- 4) Add Sel >>
- 5) Program all
- 6) if all is OK and no errors reported you can disconnect the device and close Memtool.

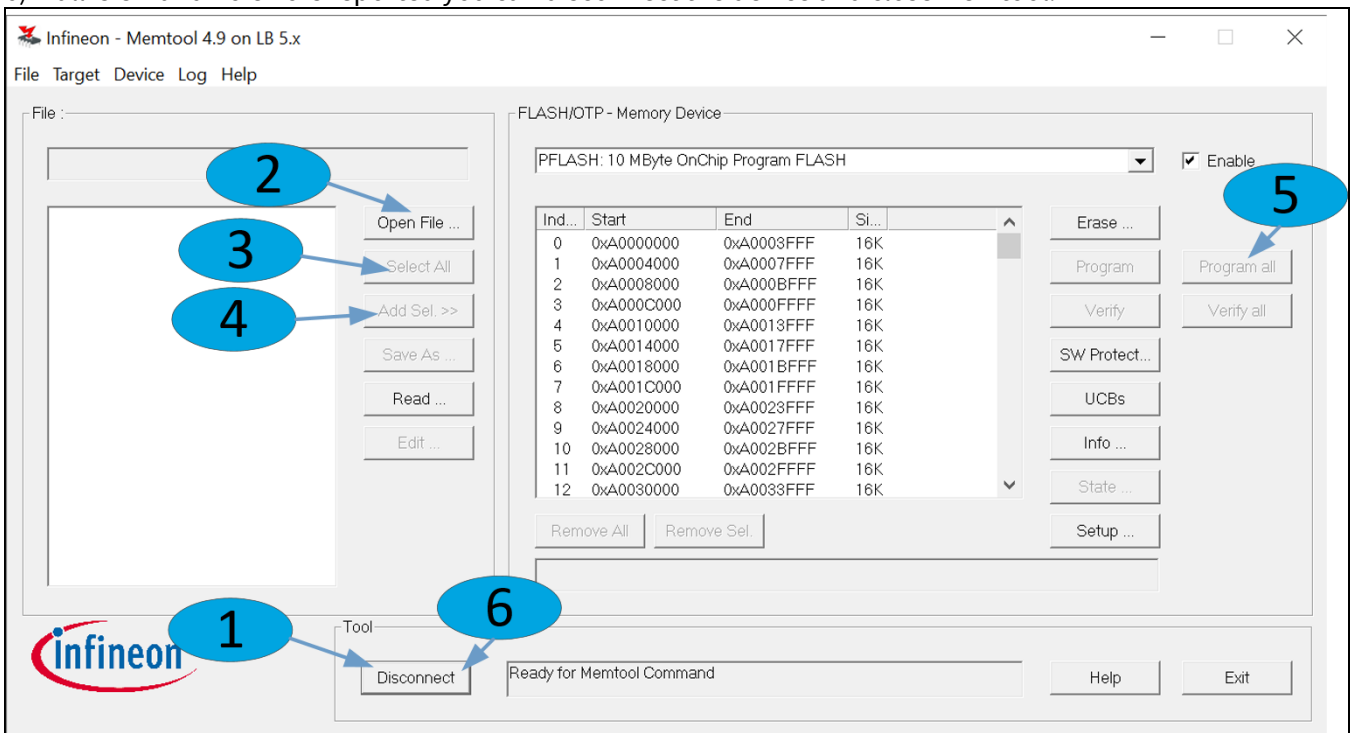

**Figure 14 Flash a compiled software (.hex) file into the target device.**

# Quickstart Guide for Inverter Evaluation Kit

## Inverter Evaluation Kit for HybridPACK™ Drive G2 Power Modules

### Trouble Shooting and further detailed Information

## 5.3 New Boards Inizialization

In the OneEye GUI you can find under Configuration the New Board Init structure. Simply follow this sequence and the part will initialize with default parameters (see Figure 15). The boards are now ready for the 1<sup>st</sup> tests.

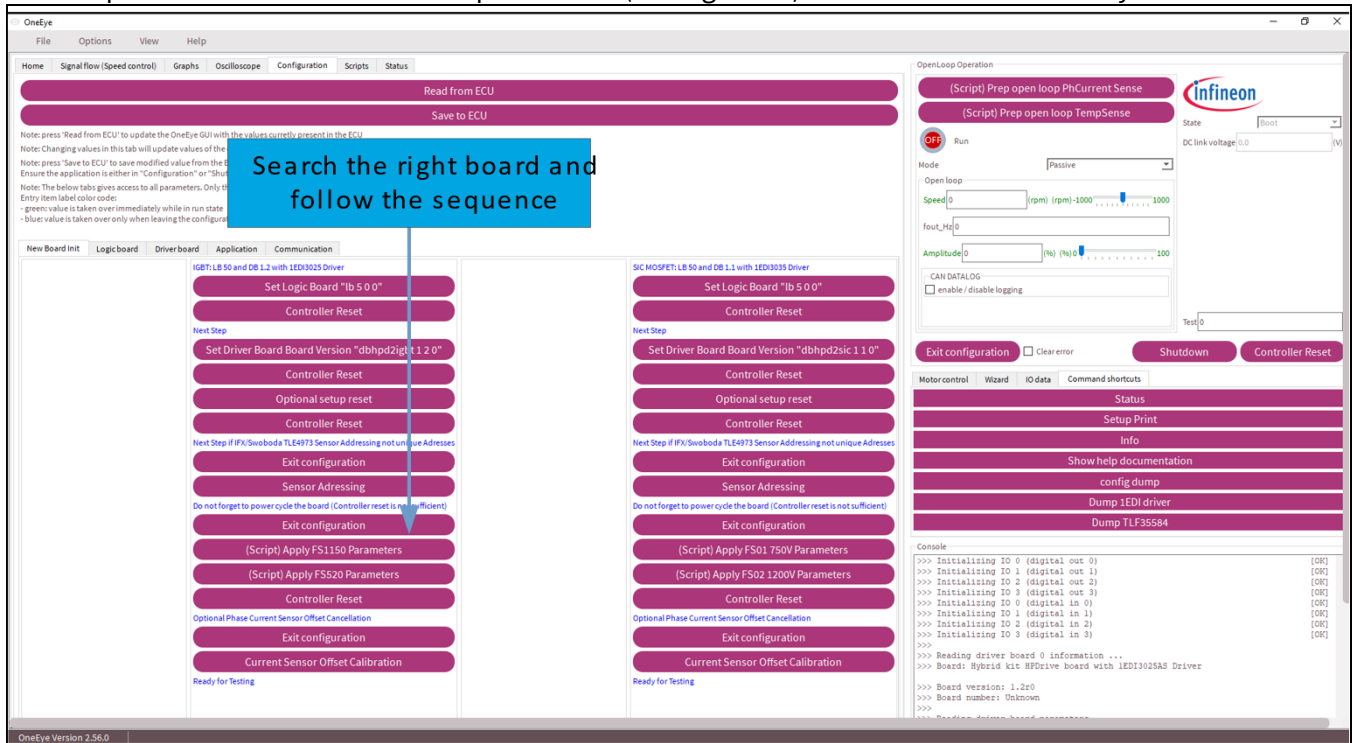

Figure 15 OneEye GUI for New Board Init sequence.

## 5.4 Extract CAN0 Messages

### 5.4.1 RX Messages (Receive by the Logicboard)

CAN ID	DLC	Interval	Size (bit)	Offset (bit)	Field	Description
0x01	2	10 ms	1	9	cmd.clearError	Request to clear the errors and exit the error state
			1	11	cmd.configExit	Request to exit the configuration state
0x02	8	10 ms	32	0	cmd.currentId	Controller: id command (A)
			32	32	cmd.currentIq	Controller: iq command (A)
0x04	4	10 ms	32	0	cmd.torque	Controller: torque command (Nm)
0x05	4	10 ms	32	0	cmd.speed	Controller: speed command (rpm)
0x0E	4	10 ms	32	0	cmd.amplitude	Controller: amplitude command (0-100)
0x13	2	10 ms	8	0	cmd.mode	Controller: mode command
			1	8	cmd.run	Controller: run command
0xFE	1	1 ms	8	0	protocol.out	Shell protocol (OUT)

### 5.4.2 TX Messages (Transmitted by the Logicboard)

CAN ID	DLC	Interval	Size (bit)	Offset (bit)	Field	Description
0x06	4	10 ms	1	9	status.error	Error status
			1	10	status.clearError	Clear error request status
			1	11	status.configExit	Exit configuration state status
			8	24	status.ecuState	ECU state
0x07	8	10 ms	32	0	status.torque	Controller: torque (Nm)
			32	32	status.speed	Controller: speed (rpm)
0x08	8	10 ms	32	0	status.vdc	Controller: Vdc (V)
			32	32	status.currentW_DB	Controller: Driverboard Phase W current (A)
0x09	8	10 ms	32	0	status.switchTemp_U_HS	Controller: Switch Temp HS Phase U (°C)
			32	32	status.switchTemp_V_HS	Controller: Switch Temp HS Phase V (°C)
0x0A	4	10 ms	32	0	status.switchTemp_W_HS	Controller: Switch Temp HS Phase W (°C)
0x0F	8	1 ms	32	0	status.currentU_DB	Controller: Driverboard Phase W current (A)
			32	32	status.currentV_DB	Controller: Driverboard Phase W current (A)
0x10	8	10 ms	32	32	status.mechPos	Controller: position (rad)
0x12	2	10 ms	8	0	status.mode	Controller: mode status
			1	8	status.run	Controller: run status
0x15	8	100 ms	32	0	status.kl30	KL30
0x16	4	100 ms	32	0	status.motorTemp0	Motor temp 0

# Quickstart Guide for Inverter Evaluation Kit

## Inverter Evaluation Kit for HybridPACK™ Drive G2 Power Modules



### Trouble Shooting and further detailed Information

CAN ID	DLC	Interval	Size (bit)	Offset (bit)	Field	Description
0x17	8	100 ms	32	0	status.ain0	LB analog input 0
			32	32	status.ain1	LB analog input 1
0x18	8	100 ms	32	0	status.ain2	LB analog input 2
			32	32	status.ain3	LB analog input 3
0x19	8	100 ms	32	0	status.ain4	LB analog input 4
			32	32	status.ain5	LB analog input 5
0x1A	2	100 ms	8	0	status.din	LB digital inputs
			8	8	status.dout	LB digital outputs
0x1B	8	10 ms	32	0	status.currentU_LB	Controller: External Logicboard Phase U current (A)
			32	32	status.currentV_LB	Controller: External Logicboard Phase V current (A)
0x1D	8	10 ms	32	0	status.currentW_LB	Controller: External Logicboard Phase W current (A)
			32	32	status.switchTemp_U_LS	Controller: Switch Temp LS Phase U (°C) or VCC2 driver supply at SIC MOSFET
0x1E	8	10 ms	32	0	status.switchTemp_V_LS	Controller: Switch Temp LS Phase V (°C) or driver board temp at SIC MOSFET
			32	32	status.switchTemp_W_LS	Controller: Switch Temp LS Phase V (°C) or redundant Vdc measurement at SIC MOSFET
0x1F	8	10 ms	32	0	status.currentSensorTempU	Driver Board Current Sensor Chip Temp Phase U
			32	32	status.currentSensorTempV	Driver Board Current Sensor Chip Temp Phase V
0x26	4	10 ms	32	0	status.currentSensorTempW	Driver Board Current Sensor Chip Temp Phase W
0xFF	8	1 ms	8	0	protocol.in	Shell protocol (IN)

## **5.5 FAQ Frequent Asked Questions**

Q1: Inverter Kit shows a wrong scaling of e.g. Vdc voltages, currents, etc.

A1: Maybe a wrong gain parameter was applied. Please check in the configuration tab in OneEYE tool the corresponding gain/offset parameters and adjust if needed.

## 6 References and Revision History

The referenced application notes can be found at <http://www.infineon.com>

- [1] Infineon Application Note AN-G2-ASSEMBLY, “Assembly Instructions for the HybridPACK™ Drive G2 power modules”.
- [2] Infineon Application Note AN-G2-SICSC, “Automotive SiC MOSFET G2 short circuit detection and turn-off with 1EDI3035AS gate driver”.
- [3] Peak-Systems, <https://www.peak-system.com/>

---

### Revision History

Date	Version	Changed By	Change Description
2023-09	0.1	T. Reiter	Initial Version
2024-01	0.2	T. Reiter	Minor update due to change of product order names following a comprehensive type designation tree.
2024-06	1.0	T. Reiter	Initial release

#### Trademarks of Infineon Technologies AG

AURIX™, C166™, CanPAK™, CIPOS™, CoolGaN™, CoolMOS™, CoolSET™, CoolSiC™, CORECONTROL™, CROSSAVE™, DAVE™, DI-POL™, DrBlade™, EasyPIM™, EconoBRIDGE™, EconoDUAL™, EconoPACK™, EconoPIM™, EiceDRIVER™, eupec™, FCOS™, HITFET™, HybridPACK™, Infineon™, ISOFACE™, IsoPACK™, i-Wafer™, MIPAQ™, ModSTACK™, my-d™, NovalithiC™, OmniTune™, OPTIGA™, OptiMOS™, ORIGA™, POWERCODE™, PRIMARION™, PrimePACK™, PrimeSTACK™, PROFET™, PRO-SiL™, RASIC™, REAL3™, ReverSave™, SatRIC™, SIEGET™, SIPMOS™, SmartLEWIS™, SOLID FLASH™, SPOC™, TEMPFET™, thinQ!™, TRENCHSTOP™, TriCore™.

Trademarks updated August 2015

#### Other Trademarks

All referenced product or service names and trademarks are the property of their respective owners.

Edition <2024-06-10>

#### Published by

**Infineon Technologies AG**

81726 Munich, Germany

© 2024 Infineon Technologies AG.

All Rights Reserved.

**Do you have a question about this document?**

Email: [erratum@infineon.com](mailto:erratum@infineon.com)

#### Document reference

AN-G2-KITQUICKSTART

#### IMPORTANT NOTICE

The information contained in this application note is given as a hint for the implementation of the product only and shall in no event be regarded as a description or warranty of a certain functionality, condition or quality of the product. Before implementation of the product, the recipient of this application note must verify any function and other technical information given herein in the real application. Infineon Technologies hereby disclaims any and all warranties and liabilities of any kind (including without limitation warranties of non-infringement of intellectual property rights of any third party) with respect to any and all information given in this application note.

The data contained in this document is exclusively intended for technically trained staff. It is the responsibility of customer's technical departments to evaluate the suitability of the product for the intended application and the completeness of the product information given in this document with respect to such application.

For further information on the product, technology, delivery terms and conditions and prices please contact your nearest Infineon Technologies office ([www.infineon.com](http://www.infineon.com)).

#### WARNINGS

Due to technical requirements products may contain dangerous substances. For information on the type in question please contact your nearest Infineon Technologies office.

Except as otherwise explicitly approved by Infineon Technologies in a written document signed by authorized representatives of Infineon Technologies, Infineon Technologies' products may not be used in any applications where a failure of the product or any consequences of the use thereof could reasonably be expected to result in personal injury.