

**Features**

- High power 3 phase bridge driver for low RDS<sub>ON</sub> N-channel FETs
- High external load capability for switching six N-channel FETs with a Q<sub>Gtot</sub> of 250 nC at 20 kHz PWM
- 0...100% duty cycle, configurable without restrictions
- Developed according to ISO 26262 ASIL-D
- SPI interface with CRC check of data and addresses
- Additional safe state pin SOFFN
- 3 current-sense ADCs for high-accuracy shunt current measurements

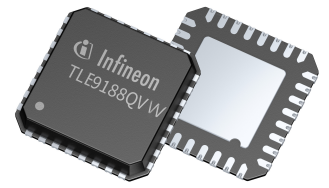

**Potential applications**

- Electric power steering (EPS)
- Electric brake booster (EBB)
- Functional safety-related BLDC or PMSM motor drive applications

**Product validation**

Qualified for automotive applications with higher temperature requirements.

Product validation according to AEC-Q100.

**Description**

The TLE9188QVW is an advanced gate driver IC designed for controlling six external N-channel power MOSFETs forming an inverter for high-current three-phase motor drive applications in the automotive sector. All low- and high-side output stages are based on a floating concept and capable of driving a wide range of N-channel power MOSFETs. The gate driver IC has an integrated DC-DC converter to ensure operation even with a low battery voltage. Motor control is possible in a supply voltage range from cranking to load dump in a 12 V battery system. The TLE9188QVW digital motor control concept supports receiving motor control patterns and sending back motor control pattern feedback and as well as motor current measurement results via an integrated SPI interface

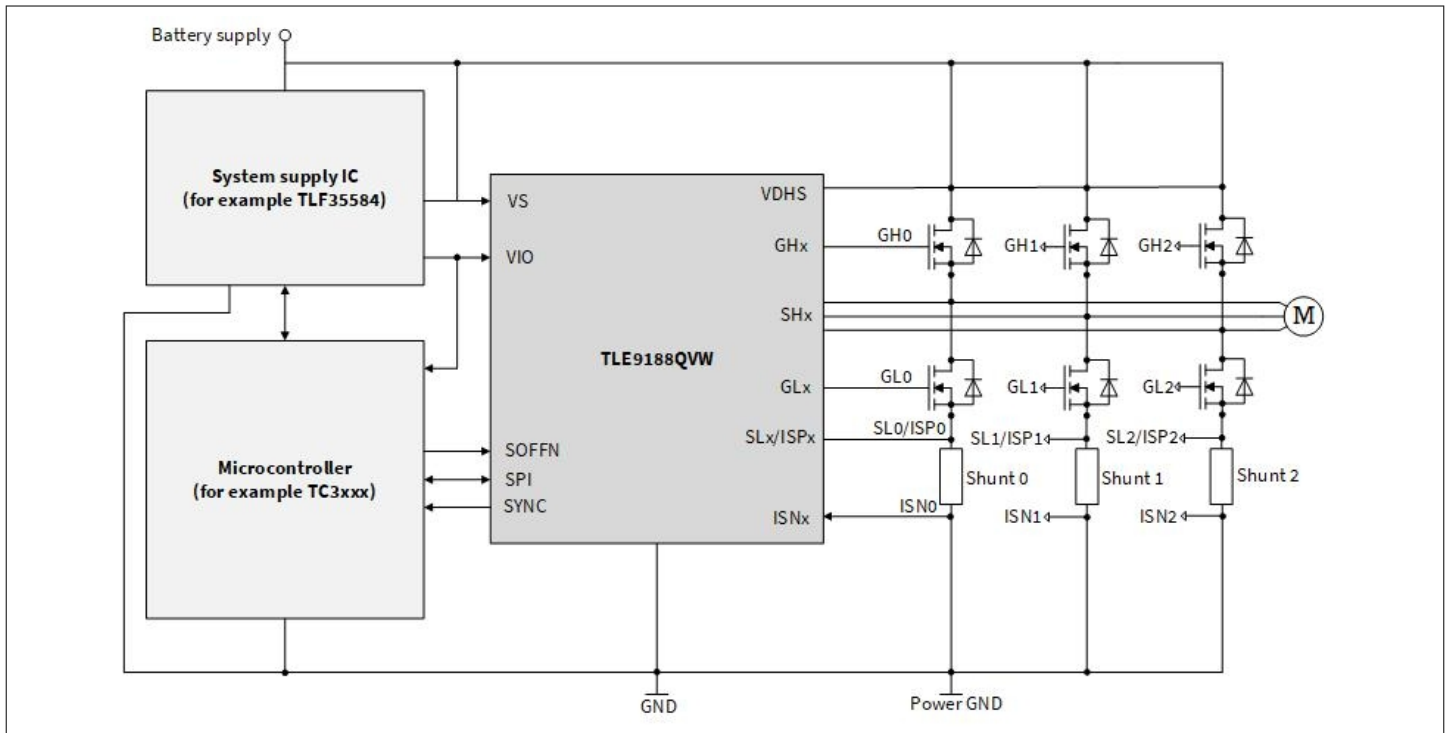

Type	Package	Marking
TLE9188QVW	PG-VQFN-32	TLE9188QVW

## Table of contents

	<b>Table of contents</b> .....	2
<b>1</b>	<b>Package outlines</b> .....	3
	<b>Revision history</b> .....	4
	<b>Disclaimer</b> .....	5

# 1 Package outlines

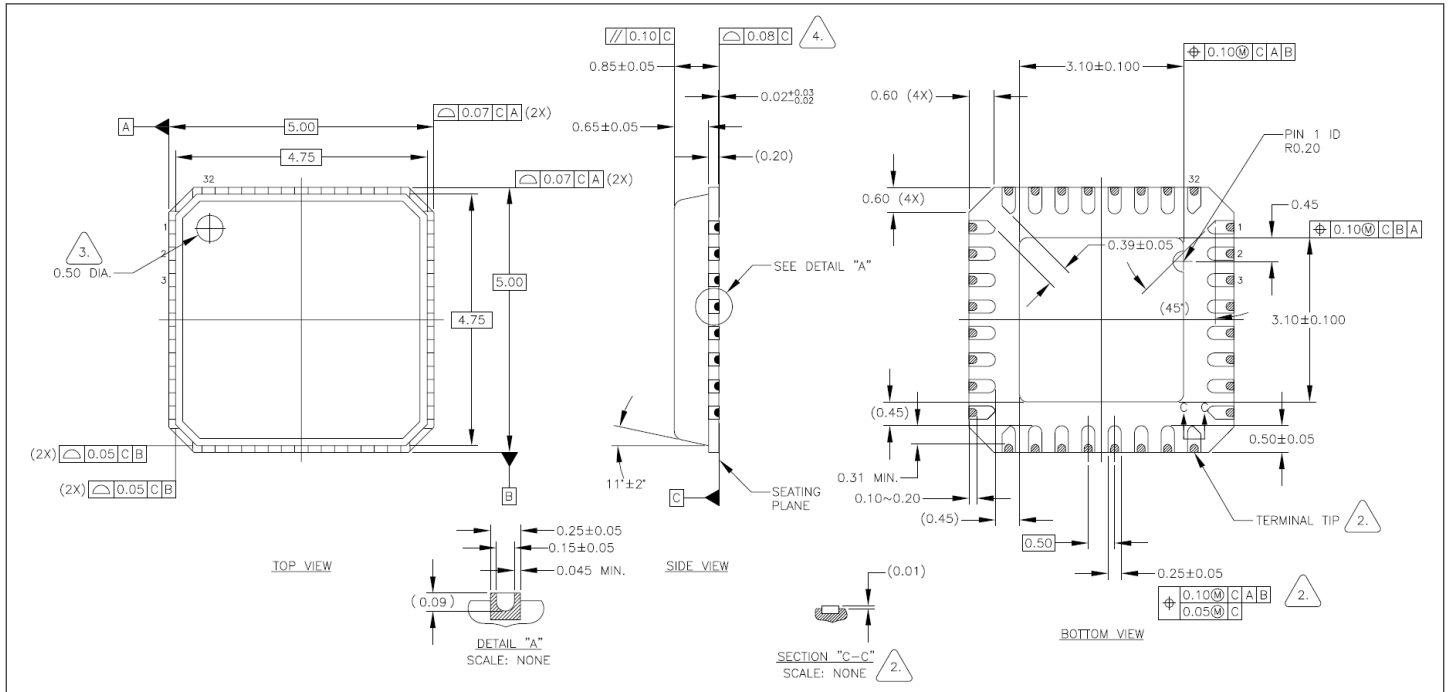

**Figure 1 Package outline drawing**

To meet the world-wide customer requirements for environmentally friendly products and to be compliant with government regulations, the device is available as a green product. Green products are RoHS-compliant (that is, Pb-free finish on leads and suitable for Pb-free soldering according to IPC/JEDEC J-STD-020).

## Revision history

<b>Document version</b>	<b>Date of release</b>	<b>Description of changes</b>
1.00	2024-09-27	Product overview available

## Trademarks

All referenced product or service names and trademarks are the property of their respective owners.

**Edition 2024-09-27**

**Published by**

**Infineon Technologies AG**  
**81726 Munich, Germany**

**© 2024 Infineon Technologies AG**  
**All Rights Reserved.**

**Do you have a question about any aspect of this document?**

**Email: [erratum@infineon.com](mailto:erratum@infineon.com)**

**Document reference**  
**IFX-fem1727353621012**

## Important notice

The information given in this document shall in no event be regarded as a guarantee of conditions or characteristics ("Beschaffenhheitsgarantie").

With respect to any examples, hints or any typical values stated herein and/or any information regarding the application of the product, Infineon Technologies hereby disclaims any and all warranties and liabilities of any kind, including without limitation warranties of non-infringement of intellectual property rights of any third party.

In addition, any information given in this document is subject to customer's compliance with its obligations stated in this document and any applicable legal requirements, norms and standards concerning customer's products and any use of the product of Infineon Technologies in customer's applications.

The data contained in this document is exclusively intended for technically trained staff. It is the responsibility of customer's technical departments to evaluate the suitability of the product for the intended application and the completeness of the product information given in this document with respect to such application.

## Warnings

Due to technical requirements products may contain dangerous substances. For information on the types in question please contact your nearest Infineon Technologies office.

Except as otherwise explicitly approved by Infineon Technologies in a written document signed by authorized representatives of Infineon Technologies, Infineon Technologies' products may not be used in any applications where a failure of the product or any consequences of the use thereof can reasonably be expected to result in personal injury.