

# Liquid-level sensing with PSOC™ 4 CAPSENSE™

## About this document

### Scope and purpose

This application note shows how to use PSOC™ 4 MCUs with the 5<sup>th</sup> Generation CAPSENSE™ technology and capacitive sensors to measure the level of water-based liquids in nonconductive containers. Sensors located on the container exterior provide real-time reporting of liquid fill level without liquid contact. This solution is also capable of rejecting foam present on the surface of the liquid. This application note covers the use of the CAPSENSE™ Middleware Library in ModusToolbox™ to design sensors and enable robust liquid-level sensing.

### Intended audience

This document is intended for engineers who need to design a liquid-level sensing solution using capacitive sensing.

**Note:** *This application note is for advanced users of CAPSENSE™ technology. If you are new to CAPSENSE™ technology, see [Getting started with CAPSENSE™ application note](#). For more information on CAPSENSE™ in PSOC™ 4 and PSOC™ 6 devices, see [PSOC™ 4 and PSOC™ 6 MCU CAPSENSE™ design guide](#).*

## Table of contents

### Table of contents

	<b>About this document</b> .....	1
	<b>Table of contents</b> .....	2
<b>1</b>	<b>Introduction</b> .....	4
<b>2</b>	<b>CAPSENSE™</b> .....	5
2.1	Environmental effects .....	5
2.1.1	Temperature .....	5
2.1.2	Mechanical variations .....	6
2.1.3	Parasitic capacitance .....	7
<b>3</b>	<b>System overview</b> .....	8
3.1	Block diagram .....	8
3.2	System components .....	8
3.2.1	Liquid sensing hardware .....	9
3.2.1.1	Performance sensitivity to air gap variations .....	9
3.2.1.1.1	Test results .....	10
3.2.2	PSOC™ 4 kit and PSOC™ 4 device .....	11
3.2.3	Software tools .....	11
<b>4</b>	<b>Sensor design</b> .....	12
4.1	Sensor design best practices .....	12
4.1.1	Level sensor .....	12
4.2	Sensor Designer Tool .....	12
4.2.1	Liquid Level x configuration .....	13
4.2.1.1	Level sensor design parameters .....	14
<b>5</b>	<b>CAPSENSE™ LLS software</b> .....	16
<b>6</b>	<b>Liquid-level features</b> .....	17
6.1	Foam rejection .....	17
6.1.1	Enabling the foam rejection feature .....	17
6.1.2	Using the foam rejection feature .....	17
6.2	Multi-profile .....	18
6.2.1	Configuring and using multi-profile in Tuner .....	18
6.3	Tank removal detection .....	21
6.3.1	Enabling the tank removal detection feature .....	21
6.3.2	Using the tank removal detection feature .....	23
6.3.3	Status indicator .....	23
6.4	Liquid presence detection .....	24
6.4.1	Enabling liquid presence feature .....	25
6.4.2	Verification .....	26
6.5	One-time factory auto-calibration .....	27

---

## Table of contents

<b>7</b>	<b>Liquid-level calibration procedure</b> .....	<b>29</b>
7.1	Level calibration .....	29
7.2	Foam rejection coefficient calculation .....	38
	<b>References</b> .....	<b>41</b>
	<b>Revision history</b> .....	<b>42</b>
	<b>Trademarks</b> .....	<b>43</b>
	<b>Disclaimer</b> .....	<b>44</b>

## 1 Introduction

---

### 1 Introduction

Liquid-level sensing (LLS) detects the level of liquid in a container. The types of liquid-level sensors include: capacitive, mechanical float, inductive, magnetic, Hall effect, optical, acoustic density, and ultrasonic. This application note describes the implementation of capacitive liquid-level sensing, which includes the design of the sensors, the calibration procedure, and the usage of the CAPSENSE™ Middleware Library to enable liquid-level sensing in a solution. This application note describes capacitive sensing liquid-level measurement, which provides noncontact, low-cost, low-power liquid-level measurement, and focuses on areas that differ from the traditional finger-touch applications using CAPSENSE™.

**Note:** *No two applications are the same and the design rules provided do not have hard limits unless specifically stated. Use the provided design recommendations as guidance and perform validation under your application conditions.*

Infineon's 5<sup>th</sup> Generation CAPSENSE™ technology enables high-resolution liquid-level measurement with a resolution of 1 mm. Liquid-level sensing is provided through the use of CAPSENSE™ Middleware Library provided with ModusToolbox™. CAPSENSE™ Middleware Library provides easy-to-use firmware and software interfaces to enable liquid-level measurement through the CAPSENSE™ hardware on the supported PSOC™ 4 devices. For more information, see [Supported devices](#).

#### Features

The liquid-level sensing solution has the following features:

- Non-contact measurement, which avoids corrosion, contamination, and cleaning difficulties
- Accurate and high resolution liquid-level sensing
- [Foam rejection](#) to correctly measure the level of a target liquid, even in the presence of foam
- Guided sensor design and calibration using the CAPSENSE™ Middleware Library
- [Tank removal detection](#), which detects when a tank is removed or not connected to the device
- [Liquid presence detection](#), which reports the presence or absence of a liquid based on a configured threshold
- [Multi-profile](#), allowing for multiple sensing profiles to be created and selected
- [One-time factory auto-calibration](#), to avoid part-to-part variation on tank and device

2 CAPSENSE™

2 CAPSENSE™

Capacitive liquid-level sensors are conductive pads or traces laid on a nonconductive material, such as PCB, plastic, or glass. The intrinsic capacitance of the PCB trace, pads, and other sensor connections is called the sensor parasitic capacitance ( $C_p$ ), as shown in Figure 1.

When a target object such as water approaches the sensor, a small amount of liquid capacitance ( $C_L$ ) is added to the  $C_p$ . Liquid-level sensing involves measuring the increased capacitance when water is near the sensor.

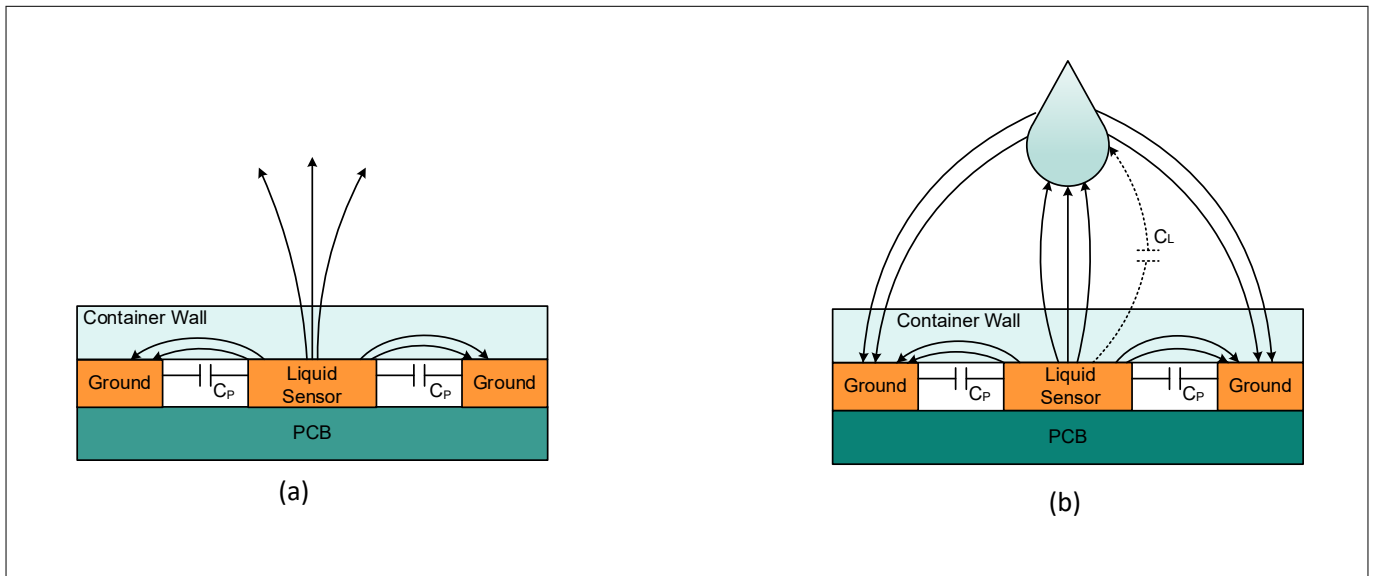

**Figure 1** Capacitance and electric field of a capacitive liquid-level sensor (a) and added capacitance ( $C_L$ ) when the liquid approaches a capacitive sensor (b)

The 5<sup>th</sup> Generation CAPSENSE™ block contains a converter that is similar to a delta sigma ADC. In the LLS system, the CAPSENSE™ block drives a signal onto the sensor. The driven signal generates a current; the voltage across the capacitance is sampled by the converter and converted into a digital value that is known as raw counts.

2.1 Environmental effects

There are several factors that impact the accuracy of a liquid-level sensing system, causing changes in the capacitance of the sensor(s) that result in reduced accuracy. Some of the most critical effects are temperature and mechanical variation.

2.1.1 Temperature

Temperature fluctuations during operation can have a significant impact on the capacitance of the system. These impacts are largely mitigated by the LLS solution; however, careful consideration and correct calibration procedures must still be followed to ensure reliable performance across temperatures.

To ensure your system functions well across temperature:

1. Calibrate your system for your typical temperature liquid by following the steps mentioned in the [Liquid-level calibration procedure](#) section
2. Fill the tank with liquid at a hot or cold relative temperature and observe the output liquid level

A temperature gradient exists as the liquid in the tank slowly settles to ambient. This temperature gradient may cause a minor reduction in accuracy but will ultimately resolve as the liquid mixes and the temperature becomes uniform.

## 2 CAPSENSE™

If the accuracy of the liquid level is not within an acceptable range across temperature, re-do the typical liquid temperature calibration, but with a small settling time of a few seconds after adding the liquid before “logging data”. This allows the liquid temperature to become relatively uniform.

### High-temperature validation results

To validate performance across temperature, the system is calibrated at normal room temperature and then tested using hot water at 65°C, 85°C, and 90°C. The resulting liquid-level readings in [Figure 2](#) shows very good accuracy across all test temperatures, confirming that the calibration is robust over this range.

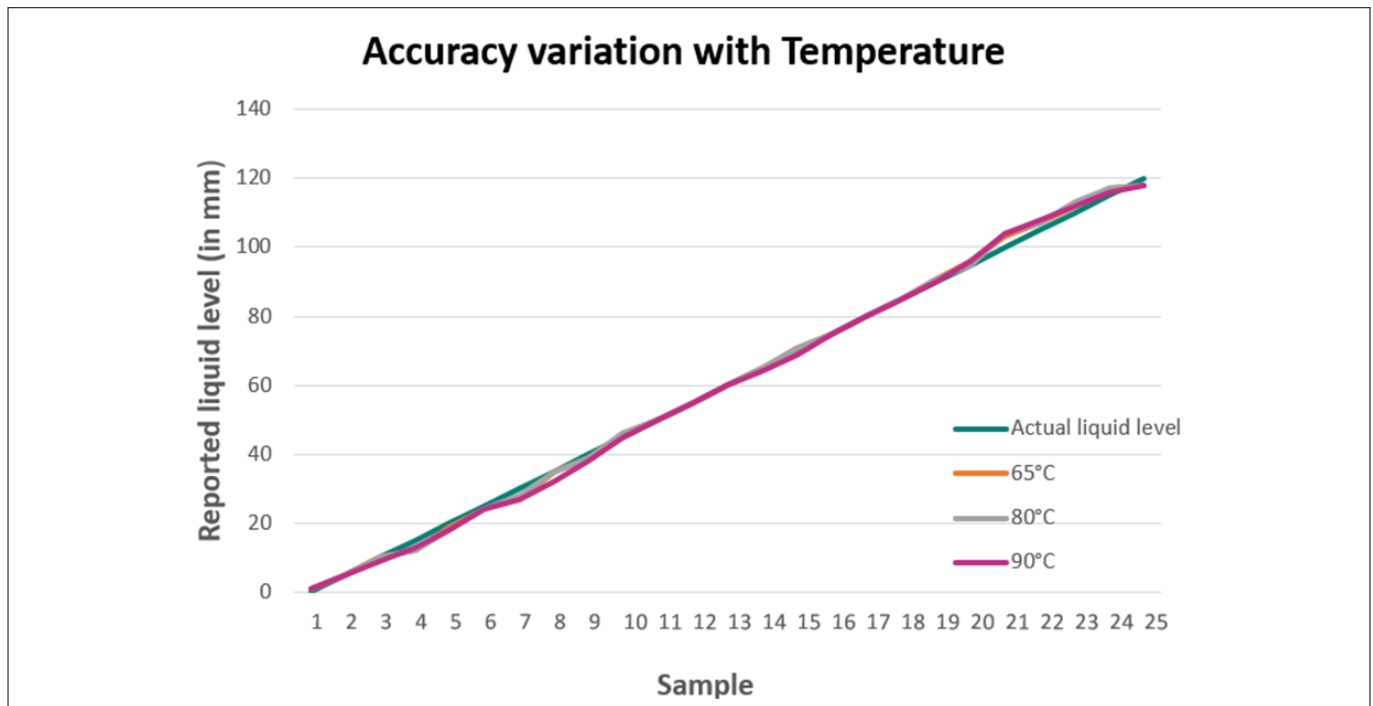

**Figure 2** Accuracy variation with temperature

### 2.1.2 Mechanical variations

Mechanical variations within the system can take many forms but all result in a change to the sensors  $C_p$ . There are two types of mechanical variations:

- **Static variation** is generally caused by manufacturing tolerances in the sensor assembly, PCB, and sensor alignment to the liquid container. If understood and controlled, static variations are compensated for during manufacturing with the calibration operation described in the [Liquid-level calibration procedure](#) section
- **Dynamic variation** is caused by changes during operation. These changes often show themselves as changes to  $C_p$  by changing the sensor’s dimensions. Like temperature changes, dynamic variation is difficult to compensate for. It is best to design the system to minimize dynamic mechanical variation effects on the sensors

#### Common mechanical variations:

- Change in the distance between the capacitor plates, where the first plate is the sensor and the second plate is the liquid surface. This can be caused by air bubbles in the adhesive used to attach the sensors to the container — the bubbles grow and shrink with air pressure
- The sensors are not directly attached to the liquid container, allowing a changing air gap between the container wall and the sensor substrate. This is a typical case for the removable tanks

To reduce the impact of such factors, ensure that there are no air bubbles present and the mechanical design is sufficient to maintain accurate sensor alignment.

### 2.1.3 Parasitic capacitance

Parasitic capacitance ( $C_p$ ) is the capacitance that results from the electric field between the sensor (including the sensor pad, traces, and vias) and other conductors in the system such as ground planes, traces, and any metal in the product's chassis or enclosure. The CAPSENSE™ block measures the total capacitance, which is the total of parasitic and liquid capacitance ( $C_{TOTAL} = C_p + C_L$ ) within the limits of its dynamic range. In systems where  $C_p$  is larger, the parameter of interest ( $C_L$ ) is proportionally smaller. Additionally, as more of the electric field couples to the ground by increasing  $C_p$ , less of the field couples to the liquid, which reduces  $C_L$ . The combined effect reduces the system sensitivity to liquid presence and therefore, total system accuracy.

The main components of parasitic capacitance in CAPSENSE™ designs are trace capacitance and sensor capacitance.  $C_p$  is a nonlinear function of sensor size, trace length, trace width, and trace-to-trace spacing. There is no simple relation between  $C_p$  and the PCB layout features, but general principles do exist. To reduce the development time of sensor patterns, ModusToolbox™ provides a graphical interface that automatically generates sensor layout based on known best practices. Additionally, a more detailed layout guidance is provided in the [Sensor design](#) section.

3 System overview

3 System overview

This section provides a high-level overview of the system components and how they are used during development and integration into a larger system.

A capacitive liquid-level sensing system has three key elements:

- Capacitive sensor pattern
- PSOC™ 4 with the 5<sup>th</sup> Generation CAPSENSE™ block  
See the [Supported devices](#) section for a list of compatible parts
- Tank with liquid to sense

3.1 Block diagram

A typical liquid-level sensing system comprises the following:

- Liquid in a container
- Sensors
- PSOC™ 4 device
- Host controller

In this system, an array of capacitive sensors on a PCB affixed near the container is connected to the CAPSENSE™ block in the PSOC™ 4 device. The CAPSENSE™ technology detects the capacitive coupling of the liquid to the sensors. PSOC™ processes the capacitance data, calculates the level of liquid present in the container, and communicates the data to the host device.

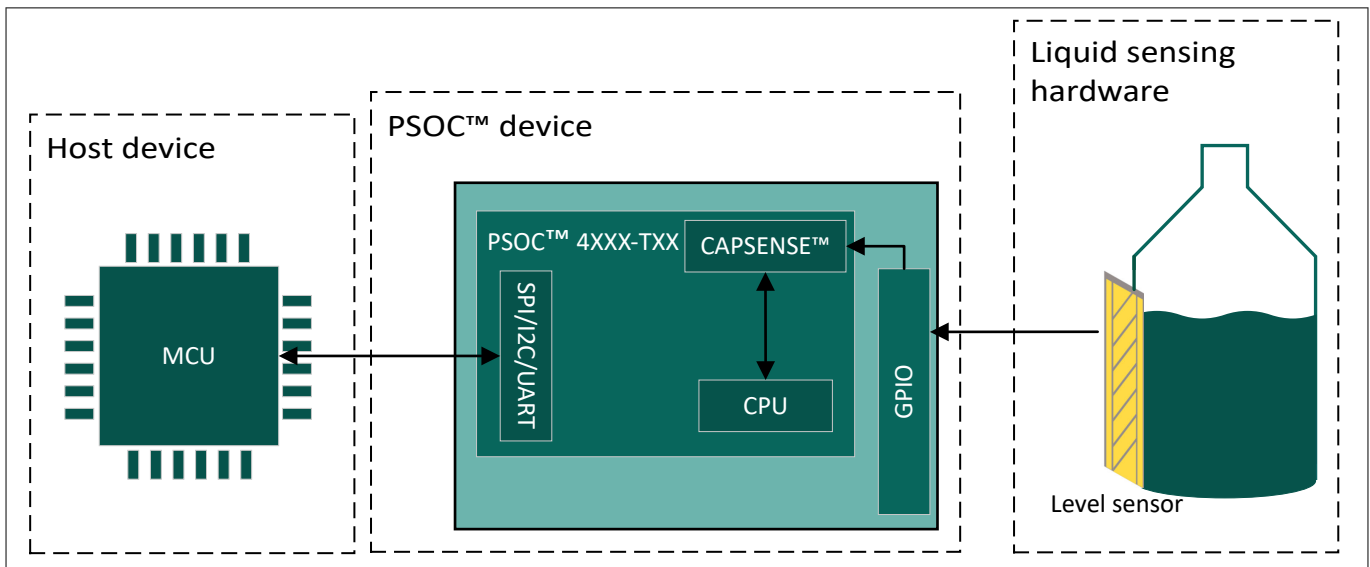

Figure 3 Liquid-level sensing system block diagram

Infineon provides several development tools, mentioned in [Software tools](#) to assist with the creation of an LLS system. These tools ease the calibration process and enable seamless tuning of an LLS system. Typically, the development process uses one of the supported PSOC™ 4 kits as well as the software tools provided as part of the CAPSENSE™ library. Hence, the high-level block diagram appears slightly different during development, which is described in the [System components](#) section.

3.2 System components

Figure 4 shows the high-level overview of the components required for developing and tuning of the liquid-level sensing system.

3 System overview

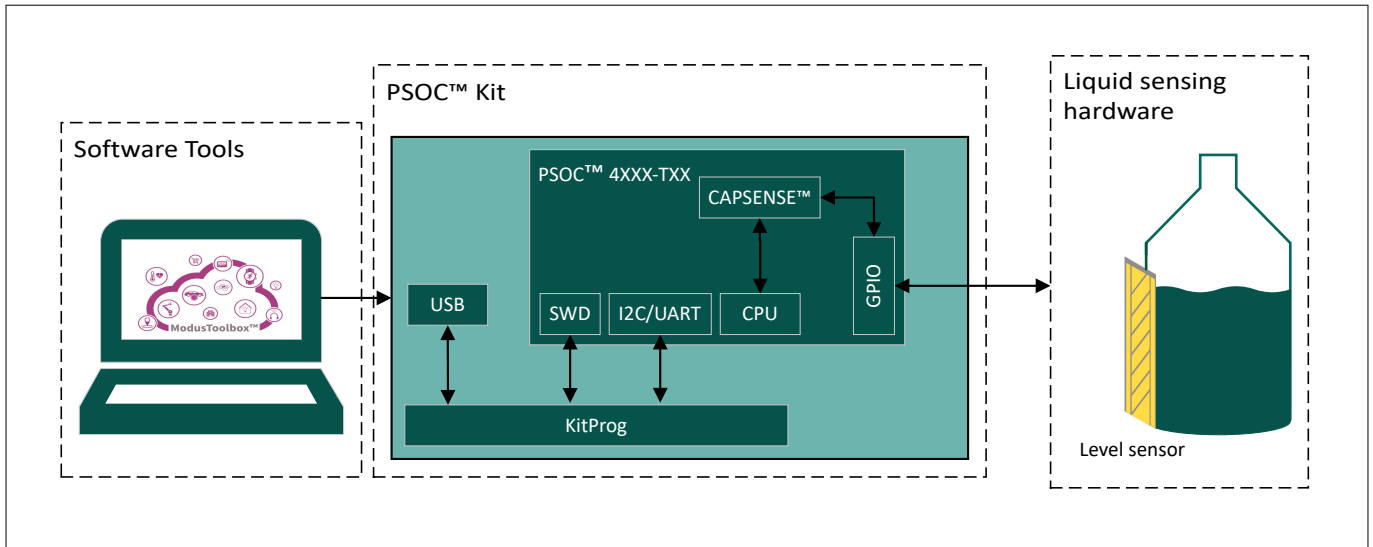

Figure 4 Liquid-level sensing block diagram in the development phase

3.2.1 Liquid sensing hardware

The following system components are common in both development and production designs:

- **Liquid:** The target liquid that is being sensed
- **Tank:** The tank is the container where the liquid that is being sensed is present. The tank material must be non-metallic and non-conductive for compatibility with the LLS system. Additionally, the tank must have a wall thickness of 5 mm or lower
- **Level sensor:** The level sensor is the capacitive sensor array that capacitively couples to the liquid to detect the liquid level. The level sensor strip may either be a rigid or flexible PCB material. The design of the sensor must follow the guidance detailed in [Sensor design](#). The liquid-level sensing solution provides a graphical tool called "Sensor Designer Tool" that can generate a sensor pattern in .dxf format, simplifying the sensor design process

The level sensor must be affixed to the side of the tank. The system does not work with the sensor segments mounted on either the bottom or top of the tank

3.2.1.1 Performance sensitivity to air gap variations

For optimal performance with varying air gaps between the sensor and the tank, perform the liquid-level factory calibration procedure (as described in the [Liquid-level calibration procedure](#) section) using the largest air gap. This calibration will also produce accurate results for smaller air gaps.

For example, if the expected air gap between the sensor PCB and the tank is 0 mm to 2 mm, calibrate the system with the largest air gap of 2 mm. The same calibration will reliably support the smaller air gaps.

Validation is performed using the experimental setup shown in [Figure 5](#), with key results summarized as follows:

### 3 System overview

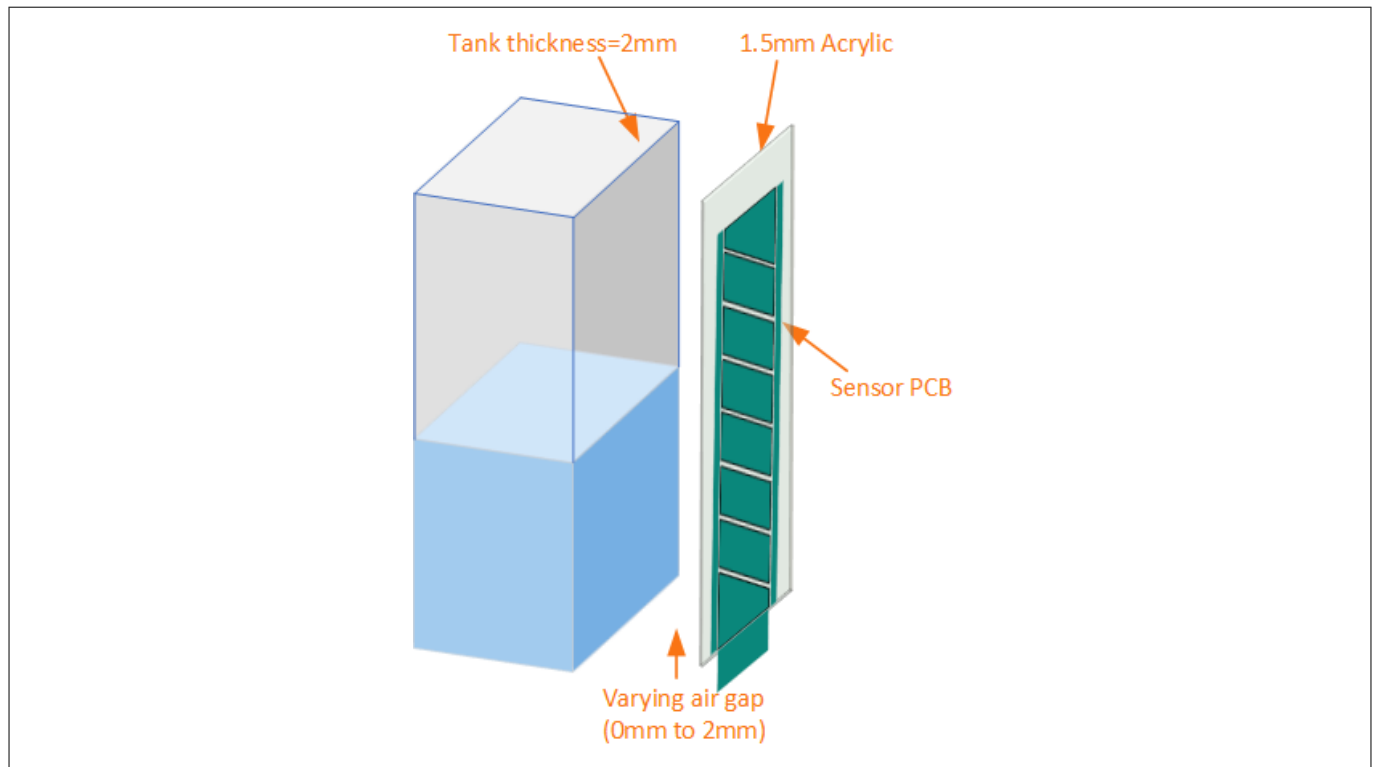

**Figure 5** Experimental setup

#### 3.2.1.1.1 Test results

**Configuration 1:** The system is calibrated with a 2 mm air gap and then evaluated for accuracy at multiple air gaps (0 mm and 1 mm). In each run, the liquid is filled at a constant speed.

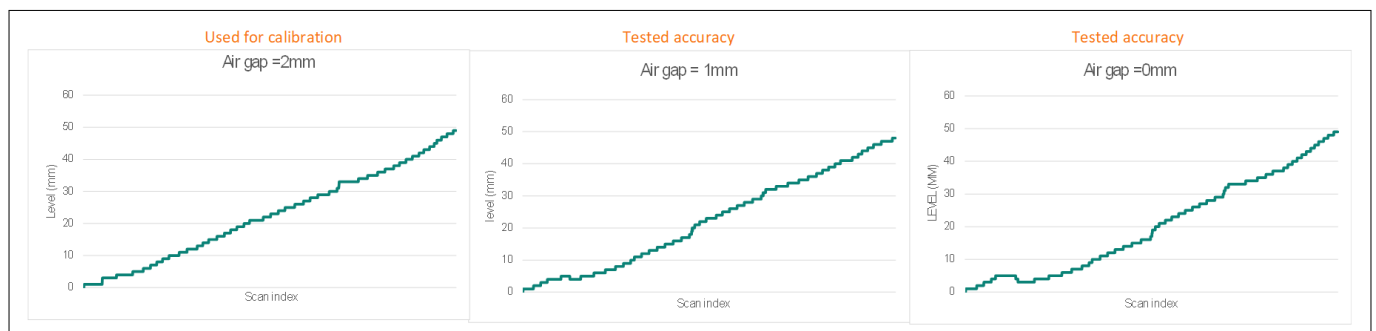

**Figure 6** Calibrated with 2 mm air gap

**Configuration 2:** The system is calibrated with a 0 mm air gap and then evaluated accuracy at multiple air gaps (1 mm and 2 mm). In each run, the liquid is filled at a constant speed.

### 3 System overview

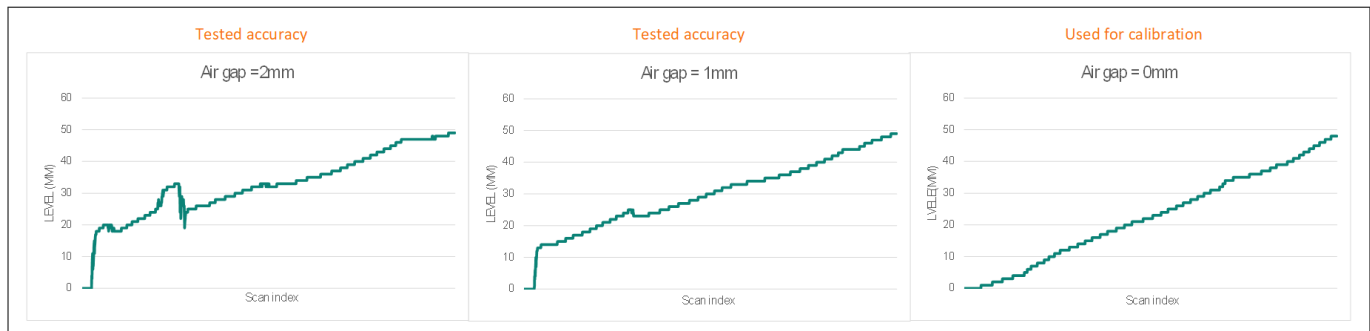

**Figure 7** Calibrated with 0 mm air gap

The graphs show that accuracy drops sharply with **configuration 2**, whereas **configuration 1** results in only a slight reduction in accuracy and keeps the model largely reliable. Therefore, it is recommended to calibrate using the largest air gap so the system maintains accuracy at smaller gaps.

#### 3.2.2 PSOC™ 4 kit and PSOC™ 4 device

- PSOC™ 4 device:** A supported PSOC™ 4 device as listed in [Supported devices](#)  
 The PSOC™ 4 device contains the CAPSENSE™ hardware that enables measurement of capacitance. The device also contains an MCU to enable the processing of the sensor data, and serial communication blocks (SCBs) to enable the communication to a host device over SPI, I2C, or UART
- PSOC™ 4 kit:** One of the supported PSOC™ 4 kits as listed in [Supported kits](#)  
 The PSOC™ 4 kit is designed to enable rapid evaluation and development of a project on PSOC™ 4. During the development of a liquid-level sensing solution, the sensor(s) can be connected to the I/O headers of a supported kit. A project created with the CAPSENSE™ Middleware Library in ModusToolbox™ can communicate with the onboard KitProg programmer/debugger to enable real-time viewing of sensing data and system calibration. The KitProg programmer/debugger is used to flash and debug the firmware via the SWD interface to the PSOC™ MCU. It also serves as a bridge between the PSOC™ MCU and CAPSENSE™ Tuner, communicating over I2C or UART

#### 3.2.3 Software tools

ModusToolbox™ provides several tools for developing an LLS solution:

- CAPSENSE™ Configurator:** Enables the configuration of the liquid-level sensing widget and selection of CAPSENSE™ hardware parameters
- CAPSENSE™ Tuner:** Enables liquid-level calibration through a guided UI. It also enables run-time configuration of sensing parameters and visualization of sensor data
- CAPSENSE™ Middleware Library:** The middleware can be used to develop liquid-level sensing applications and it provides APIs to simplify firmware development
- Sensor Designer:** Provides a graphical interface to design and generate liquid-level sensors in *.dxf* format

For more information on the software tools in the scope of the LLS solution, see [CAPSENSE™ LLS software](#).

4 Sensor design

4 Sensor design

The LLS system requires carefully designed sensor patterns to avoid inaccuracies caused by variation, environmental impacts, and high parasitic capacitance. This section discusses the software tool packaged as part of ModusToolbox™ as well as the best practices for designing liquid-level sensors.

4.1 Sensor design best practices

4.1.1 Level sensor

The recommended design for a liquid-level sensor is a “segmented” pattern. It is composed of parallelograms arranged in a strip with ground pads on either side. A segmented sensor has parameters that can be configured for optimal performance, as Figure 9 shows.

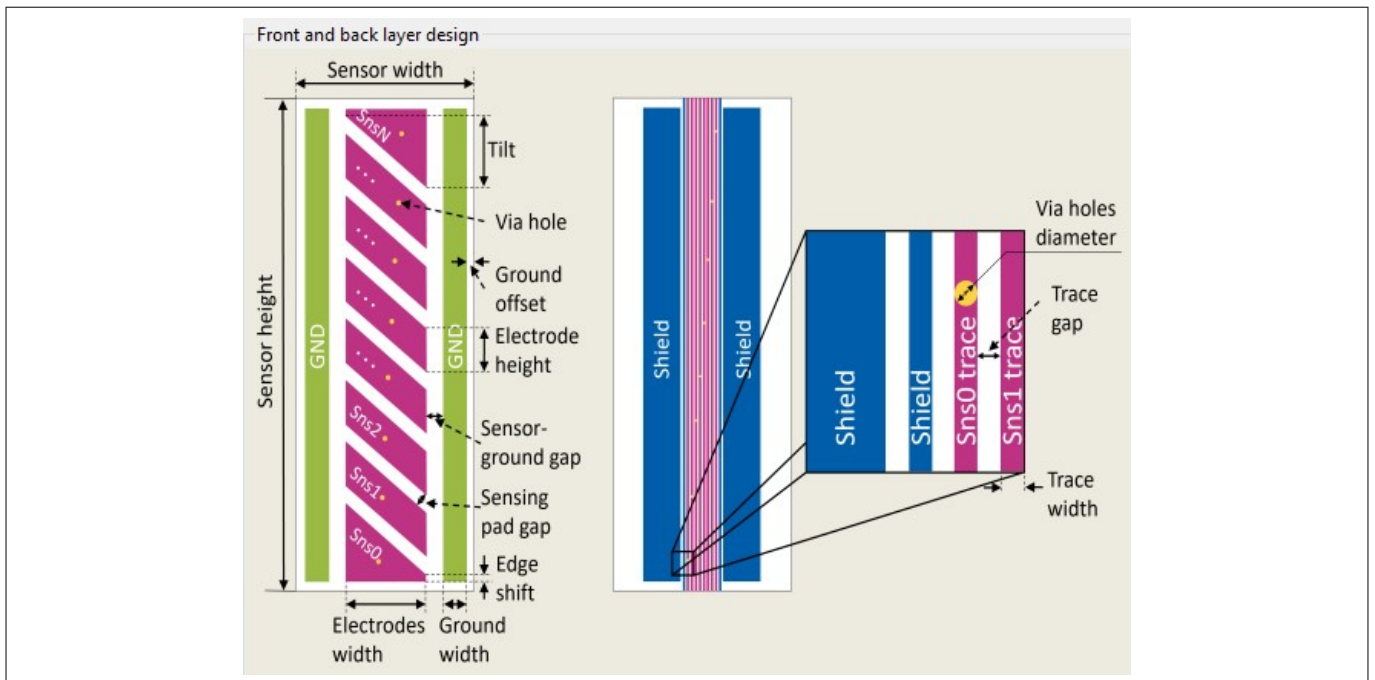

Figure 8 Liquid-level sensor with labels

Generally, a liquid-level sensor should be designed such that the sensor height is equal to or slightly larger than the maximum level of liquid that is being detected. The sensor width should be between 30 mm and 60 mm. The specific design of the level sensor depends on whether or not the liquid being detected is grounded. A grounded liquid is directly coupled to the same system ground as the sensor array and often requires a grounded contact submerged in the liquid. A grounded liquid couples to the sensor strongly and induces a large liquid capacitance ( $C_L$ ). An ungrounded liquid does not have a direct contact with the system ground, instead it capacitively couples to the ground on the external sensor through the wall of the tank material. The ungrounded liquid induces a smaller  $C_L$  relative to the grounded liquid.

**Note:** The sensor pattern is complex and it is recommended to use the [Sensor Designer Tool](#).

4.2 Sensor Designer Tool

The Sensor Designer Tool is provided with the [ModusToolbox™ CAPSENSE™ and Multi-Sense Pack](#), which will be installed automatically when installing ModusToolbox™ 3.7 or later, using [ModusToolbox™ Setup](#). This can be

## 4 Sensor design

accessed in any ModusToolbox™ project that uses a compatible device listed in [Supported devices](#) and enables the CAPSENSE™ Middleware Library. The tool provides a graphical interface with user-input options to design and generate a .dxf file containing an LLS sensor pattern.

### 4.2.1 Liquid Level x configuration

The **Liquid Level x** tab contains the calculator tool for generating a liquid-level sensor pattern, as [Figure 9](#) shows. This tab allows you to input several values, calculate sensor dimensions, and generate a .dxf file of the calculated pattern.

The UI elements numbered in [Figure 9](#) are as follows:

- 1. Generate DXF:** Generates a .dxf file containing the calculated sensor pattern. The .dxf file may be imported into CAD or EDA programs to enable rapid development of a PCB containing the sensor pattern
- 2. Save configuration:** Saves the input values and other calculated values that can be loaded with the **Load configuration** button
- 3. Load configuration:** Loads a previously saved sensor design

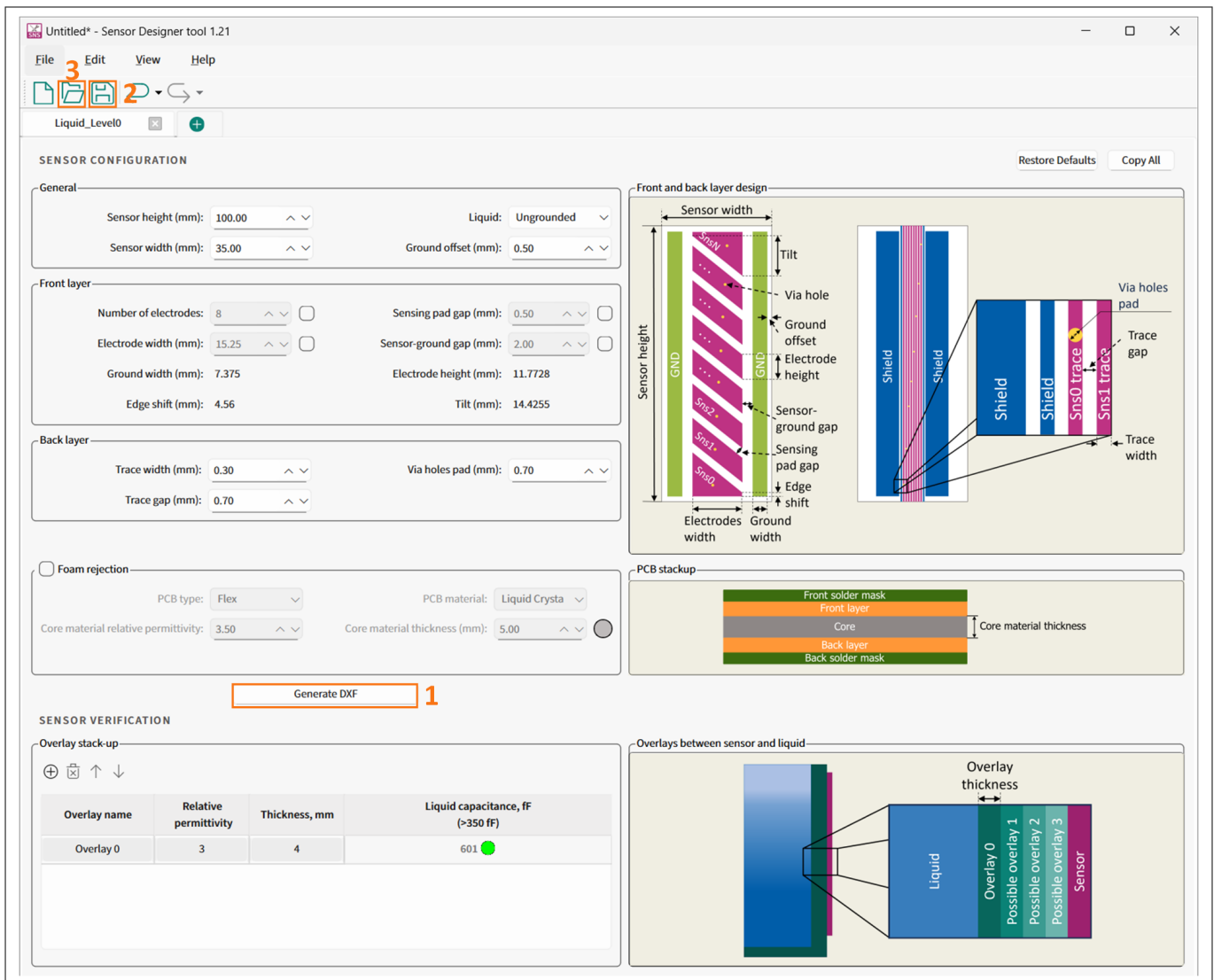

Figure 9 Liquid Level x configuration

4 Sensor design

4.2.1.1 Level sensor design parameters

This section covers the user-configurable parameters that are used primarily to generate the design of the sensor.

- **Sensor height:** The value for the total vertical height of the sensor in mm
- **Sensor width:** The value for the total width of the sensor in mm
- **Liquid:** Specifies the liquid as “grounded” or “ungrounded”  
A grounded liquid has direct contact to the shared system ground through a submerged contact. In many systems, the liquid is ungrounded
- **Ground offset:** The value for the spacing between the outer perimeter of the sensor and the ground pad in mm
- If foam rejection is required, enable the foam rejection block as [Figure 10](#) shows and configure the below parameters:

**Note:** *If foam rejection is required, avoid using flex-based PCBs. For accurate foam rejection measurements, FR4 PCBs are strongly recommended*  
*In case, if flex-based PCBs are necessary for the application, use thicker flex PCBs. Thin flex PCBs increase parasitic capacitance between active sensors and the shield, potentially reducing accuracy*

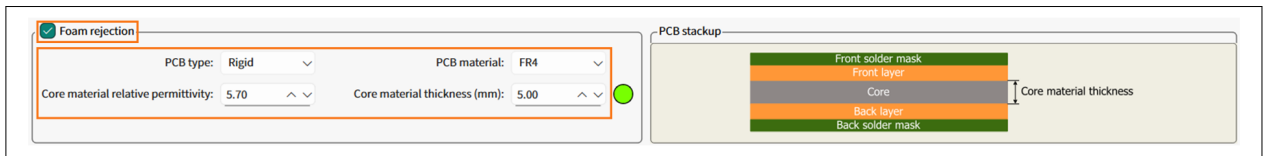

**Figure 10 Enable foam rejection block**

- **PCB type:** The PCB technology used for the sensor: Rigid, Flex, Other
- **Core material relative permittivity:** The relative permittivity of the PCB core material
- **PCB material:** The PCB base material used for the sensor
- **Core material thickness (mm):** The thickness of the PCB core material between the conductive layers

**Note:** *Smaller spacing is suggested. The smallest spacing may be limited by the capabilities of PCB fabrication technology.*

The following fields are automatically calculated by the tool. These fields can be edited by selecting the checkbox:

- **Number of Electrodes:** The value for the total number of sensors. By default, this gets optimally calculated from the given sensor height. It can be changed by checking the checkbox next to the parameter. Reducing the number of electrodes from the recommended value might lead to lower accuracy. Increasing the number of electrodes might increase the accuracy, but at the cost of pins and power

**Note:** ***Minimum number of electrodes required:** To use the **Liquid Presence widget** as defined in [Liquid presence detection](#), a minimum of 3 electrodes are required, as a three-electrode liquid level sensor is necessary for accurate presence/absence detection.*

- **Electrode width:** The value for the width of the sensor electrodes in mm
- **Sensing pad gap:** The value for the distance between adjacent electrode pads in mm, which is typically around 0.5 mm
- **Sensor-ground gap:** The value for the distance between the outer edge of the electrode pads and the ground strips on the sides of the sensor in mm which is typically around 2 mm to 4 mm
- **Trace width:** The value for the width of the traces that are routed to the sensors in mm

---

## 4 Sensor design

The minimum value supported by the PCB manufacturer is recommended

- **Trace gap:** The value for the spacing between adjacent traces in mm  
The minimum value supported by the PCB manufacturer is recommended
- **Via holes diameter:** The value for the diameter of the vias that connect the trace to the top layer sensor in mm
- **Overlay stack-up:** This segment enables the estimation of whether the overlay material between the sensor and the wall of the liquid container is acceptable. A greater overlay thickness and lower relative permittivity results in a decrease in capacitance coupled by the liquid with the sensor. Multiple overlays can be added, as long as the shown liquid capacitance remains higher than the recommended value

### 5 CAPSENSE™ LLS software

This section assumes that you are familiar with CAPSENSE™ Middleware Library, including the CAPSENSE™ Configurator and Tuner software tools. For more information on CAPSENSE™ Middleware Library and the software tools provided, see the [Related resources](#) section.

The liquid-level solution is enabled through the CAPSENSE™ Middleware Library provided with ModusToolbox™. To enable the software, create a project in ModusToolbox™ and import the latest version of the CAPSENSE™ Middleware Library. The CAPSENSE™ Middleware Library provides the API for enabling, configuring, scanning, and reading of the capacitive sensor data. ModusToolbox™ provides CAPSENSE™ Configurator and CAPSENSE™ Tuner that is used for configuring and reading LLS data.

For more details, see the [PSOC™ 4: MSCLP CAPSENSE™ liquid-level sensing](#) code example.

## 6 Liquid-level features

### 6 Liquid-level features

#### 6.1 Foam rejection

This feature allows for accurate sensing of liquid levels, ignoring any foam present.

##### 6.1.1 Enabling the foam rejection feature

To enable the tank removal detection feature, go to **CAPSENSE™ Configurator > Advanced > Widget Details > Select Liquid\_Level\_xx widget** and select **Enable foam rejection** as [Figure 11](#) shows.

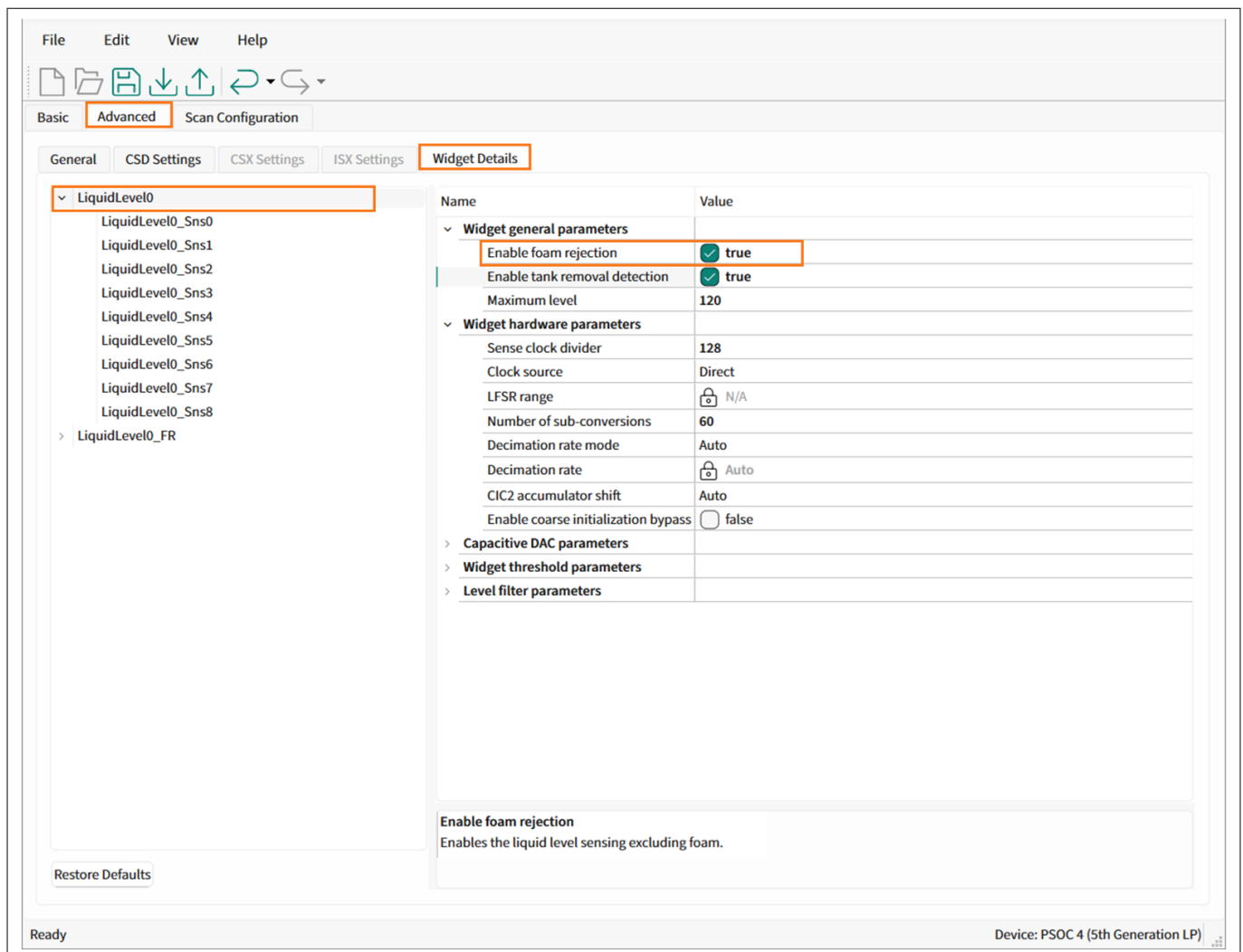

**Figure 11** Foam rejection

##### 6.1.2 Using the foam rejection feature

To use the foam rejection feature, see the [Liquid-level calibration procedure](#) section for the calibration steps.

6 Liquid-level features

6.2 Multi-profile

The multi-profile feature can create and manage multiple calibration profiles, each representing a unique combination of a PSOC™ device and a specific tank. This feature is designed to enhance the robustness and accuracy of the liquid-level sensing (LLS) solution by allowing the combination of data from multiple profiles. The multi-profile feature offers several key benefits, including:

- **Improve accuracy:** Combine data from multiple profiles to improve the accuracy of the LLS solution, reducing the impact of variations in individual units
- **Reduced calibration efforts:** Simplified calibration process, reducing the time and effort required to calibrate multiple units
- **Increased user flexibility:** To create and manage multiple profiles, tailored to specific use cases and requirements
- **Better data utilization:** To combine and utilize data from multiple profiles, maximizing the value of collected data

6.2.1 Configuring and using multi-profile in Tuner

1. **Add a New Profile:** Navigate to the **Liquid Level Measurement** tab and click the "+" icon to create a new profile as [Figure 12](#) shows

**Note:** The "+" icon to add a new profile is only available prior to completing the **Finish Calibration** step, meaning that you must add all desired profiles before proceeding to finish the calibration process.

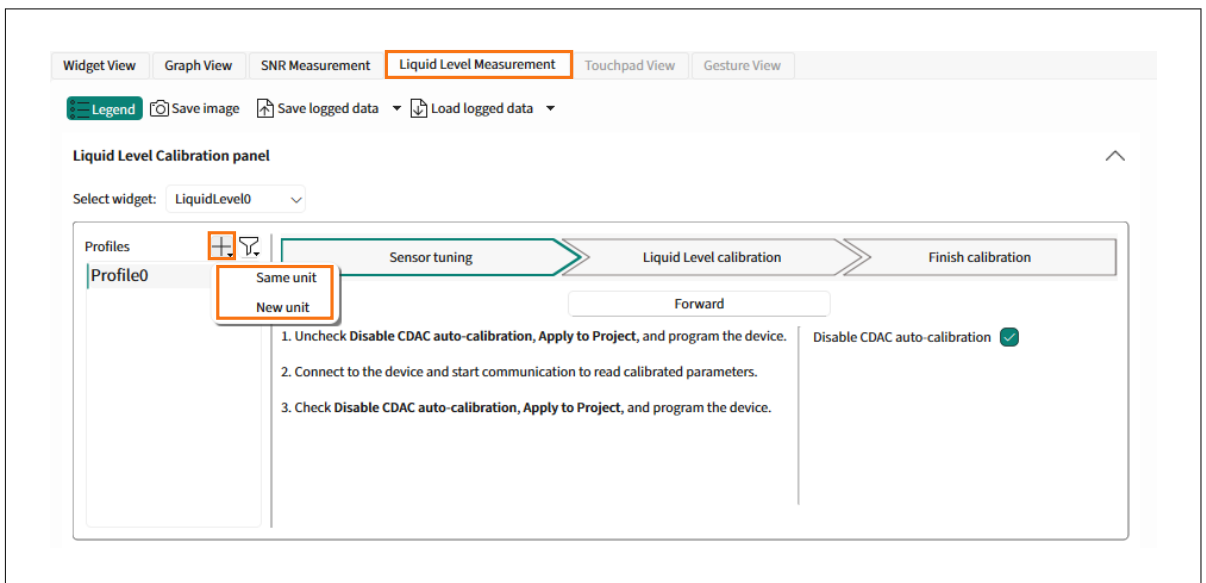

Figure 12 Add profile

**Same unit:** Create a profile for the same as the current profile setup to continue calibration

**New unit:** Create a profile for the new setup to pass the Sensor Tuning stage before collecting liquid level

**Note:** For a **new unit**, follow the entire [Level calibration](#) procedure mentioned in [Level calibration](#) section, starting from [Step 2](#). However, for the **same unit**, you can skip [Step 2](#) of the [Level calibration](#) procedure and proceed with the remaining steps

## 6 Liquid-level features

- To manage a profile, including deleting, clearing data, or duplicating, hover on the profile name and then select the three dots (as illustrated in Figure 13) to access these options. Additionally, you can also rename a profile by double-clicking on the profile name

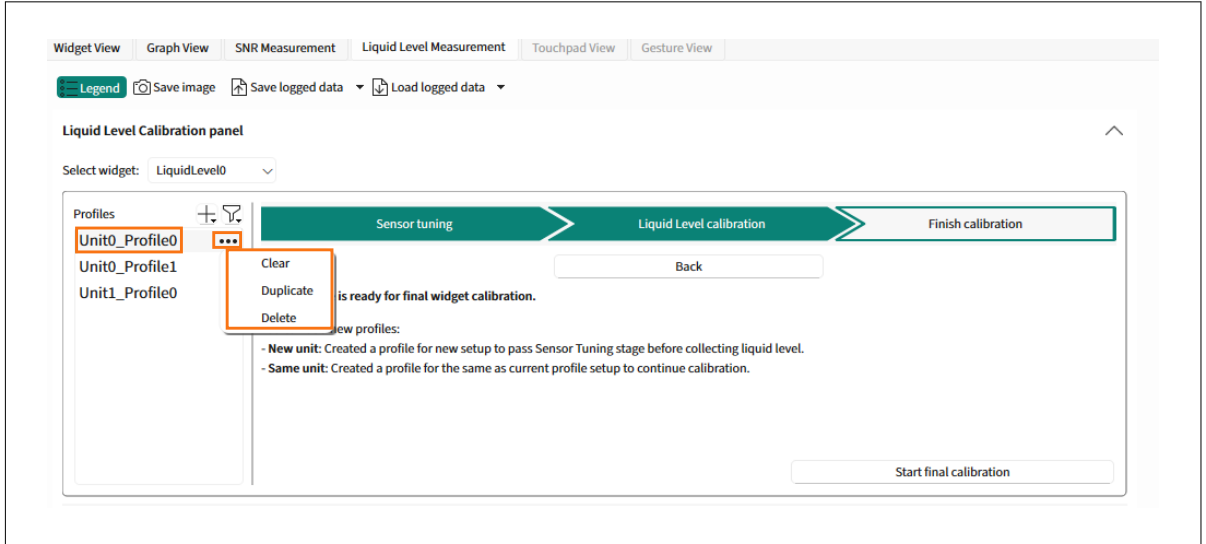

**Figure 13** Profile settings

- After data logging is complete, click **Start final calibration** that will allow you the option to select the specific profiles that you wish to utilize for the final calibration of the data as Figure 14 shows

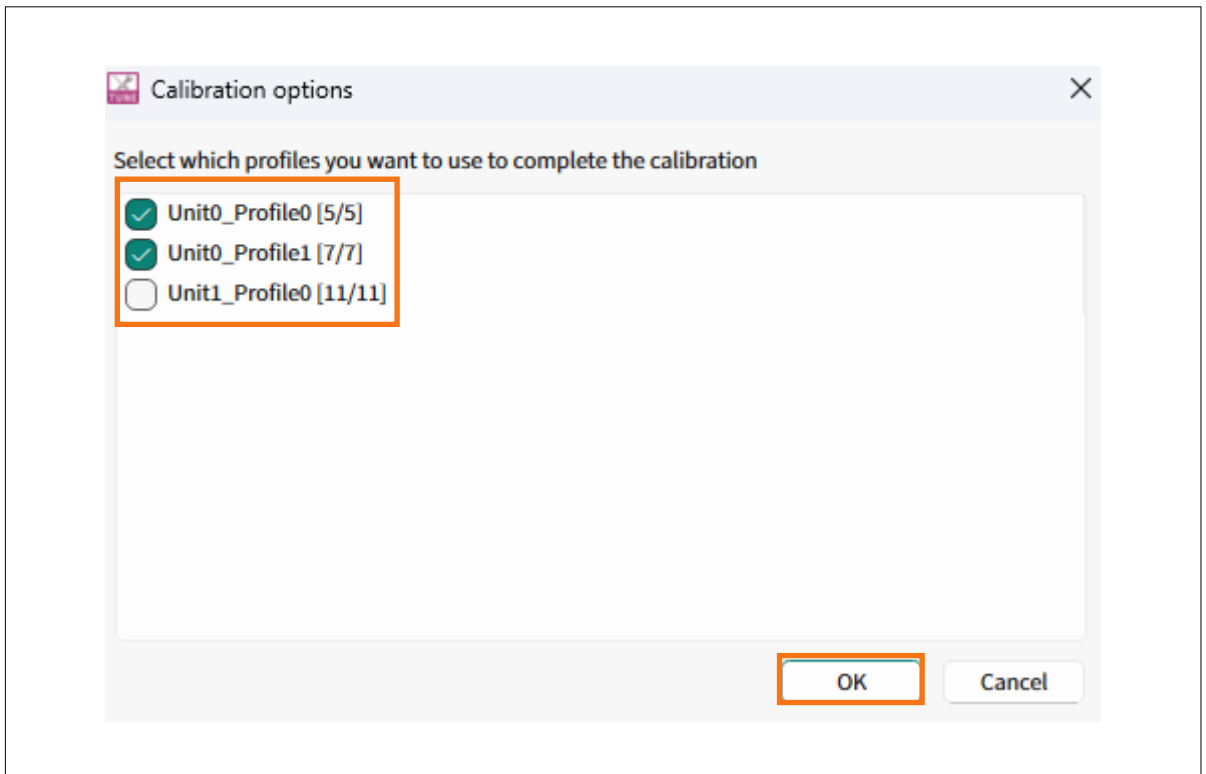
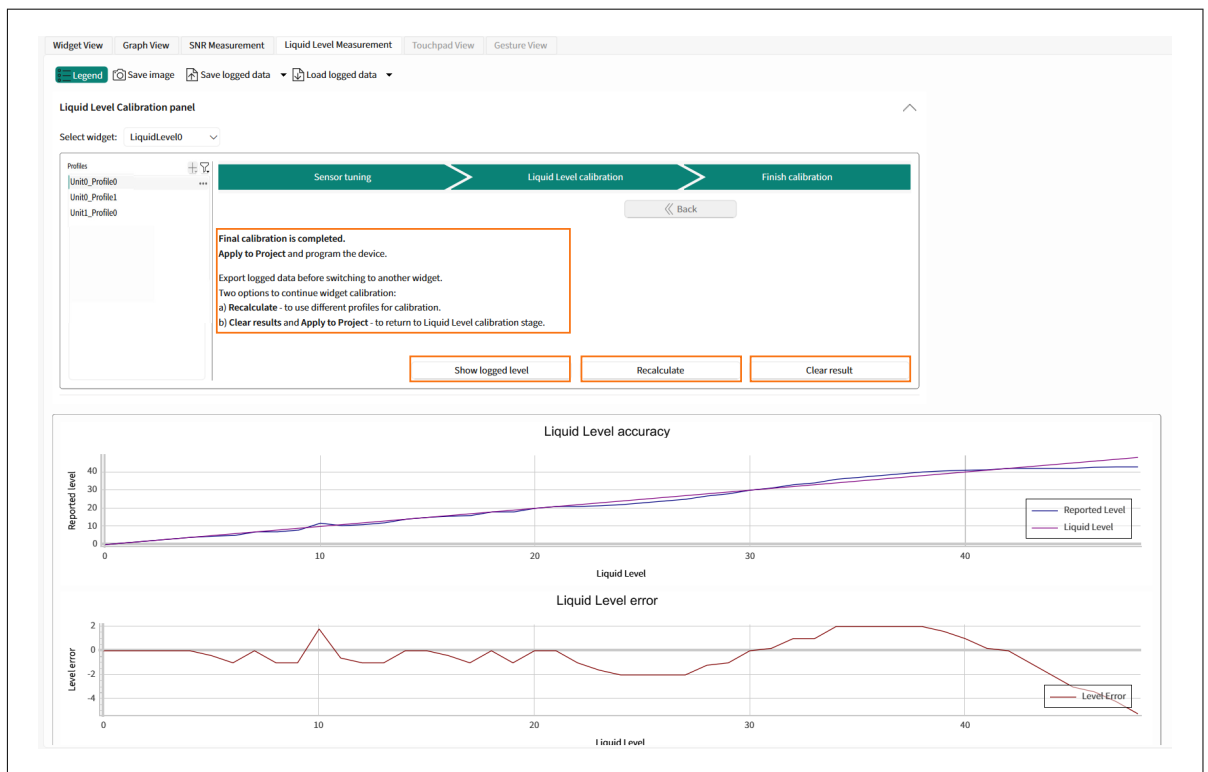

**Figure 14** Select calibration profiles

## 6 Liquid-level features

**Note:** When utilizing this feature, it is essential to ensure that at least one profile meets the validity criteria. This includes containing data logs for empty and at least one level. Additionally, "No tank data" is required if tank removal detection is enabled. Similarly, if foam rejection is enabled, foam rejection data must also be logged

- After completing the calibration, you will have the flexibility to recalculate the calibration using different profiles, and the option to clear the existing results as [Figure 15](#) shows



**Figure 15 Calibration completed**

Clicking on **Show logged level** provides the option to not only view the data for the selected unit but also to re-log the data if needed as [Figure 16](#) shows

## 6 Liquid-level features

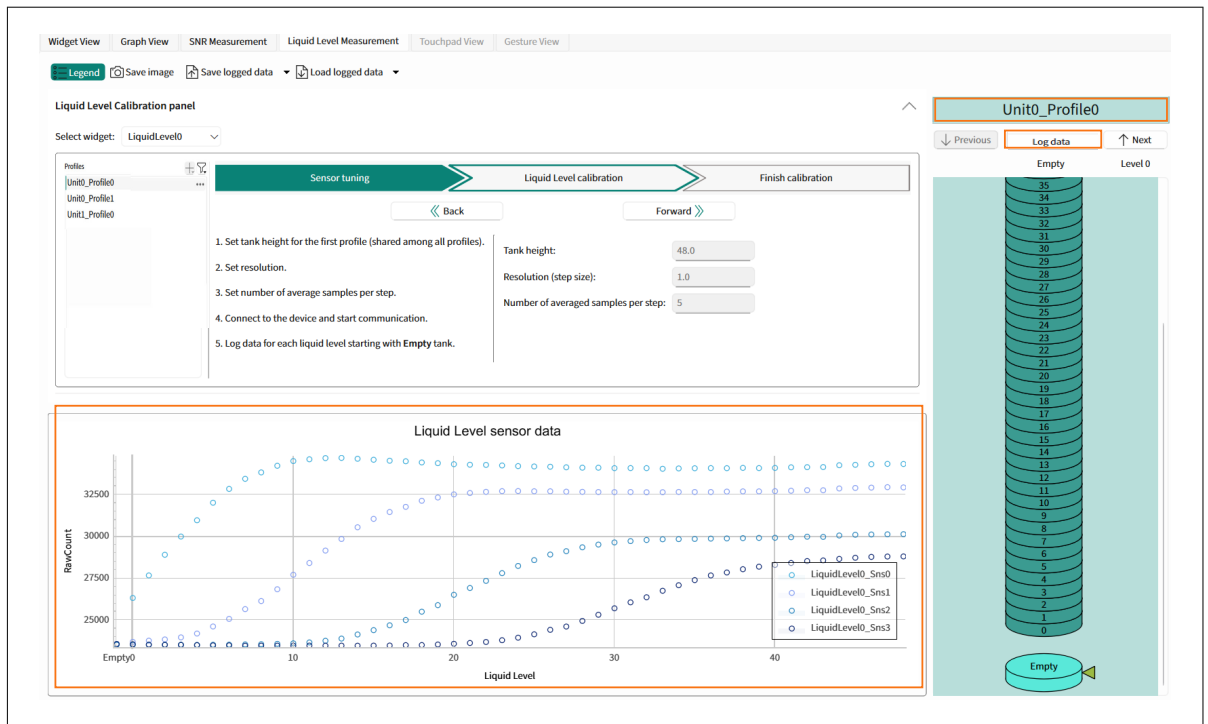

**Figure 16** Show logged level

**Note:** When utilizing a multi-profile feature, it is essential that the hardware setup remains identical. For instance, when creating a new unit, you will not be permitted to modify the tank height, as this would alter the hardware setup.

### 6.3 Tank removal detection

This feature indicates if a physical tank is connected to the device or removed.

#### 6.3.1 Enabling the tank removal detection feature

To enable the tank removal detection feature, follow these steps:

1. Go to **CAPSENSE™ Configurator > Advanced > Widget Details > Select Liquid\_Level\_xx** widget and select **Enable tank removal detection** as [Figure 17](#) shows

## 6 Liquid-level features

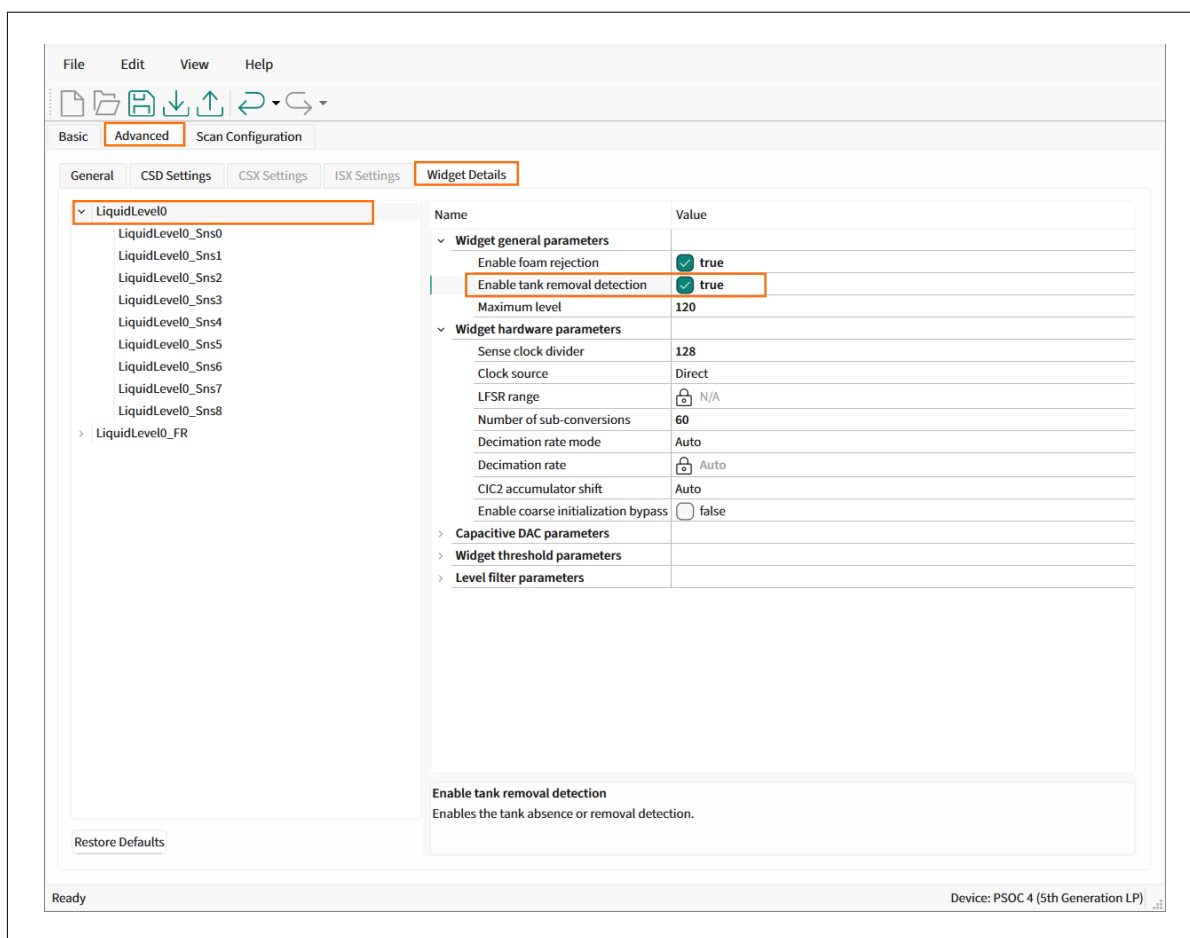
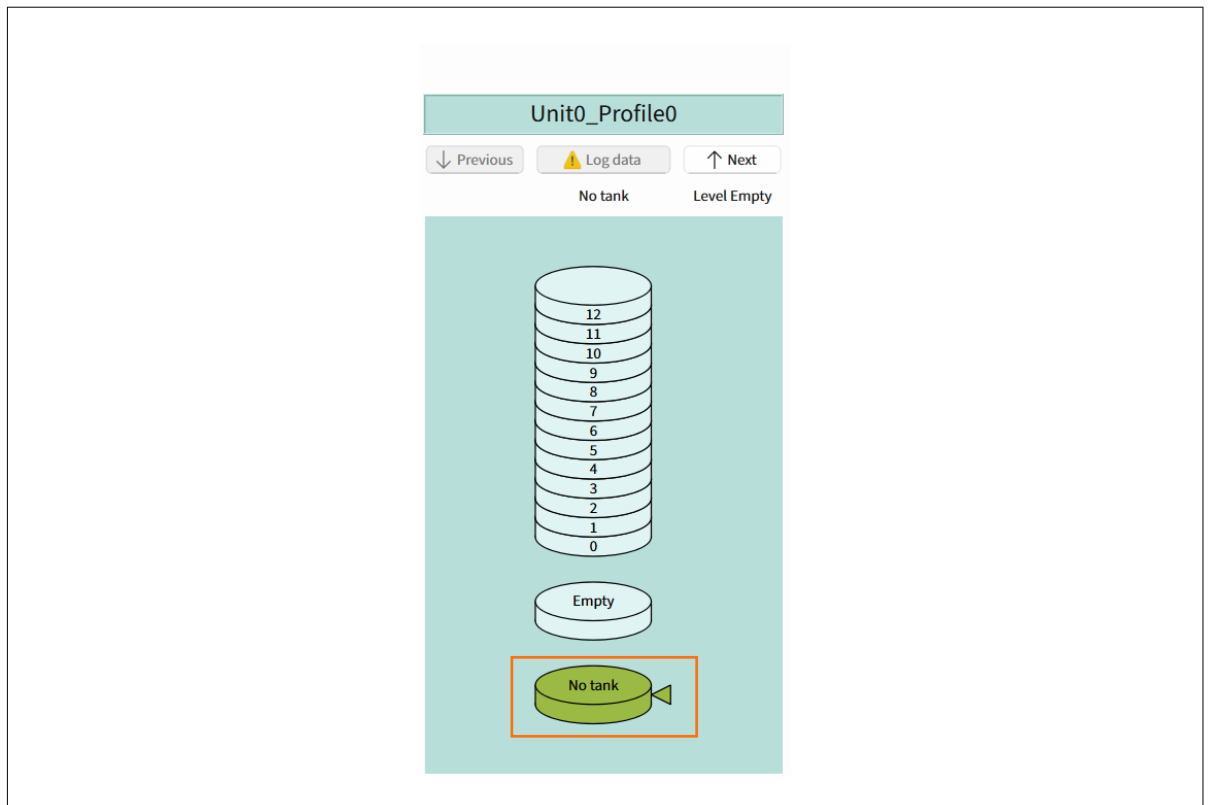

**Figure 17** Enable tank removal detection in CAPSENSE™ Configurator

**Note:** For the Foam Rejection widget, enabling the tank removal detection feature is not applicable, as the setting enabled for the Liquid Level widget will automatically apply to it

- Once enabled, a new step will be included in the calibration process named **No tank** as Figure 18 shows

## 6 Liquid-level features



**Figure 18** Progress bar showing No tank in CAPSENSE™ Tuner

### 6.3.2 Using the tank removal detection feature

To use this feature, log data with the tank fully removed as indicated in the [Level calibration](#) section Step 5 (a). This will allow the device to detect the absence of the tank and provide the necessary notifications.

### 6.3.3 Status indicator

After completing the calibration procedure and programming the device, you can view the tank removal indication. Upon removal of the tank, the device will provide a visual indication by graying out the tank icon and displaying the label "No tank detected", as shown in [Figure 19](#), thereby alerting you to take necessary actions.

## 6 Liquid-level features

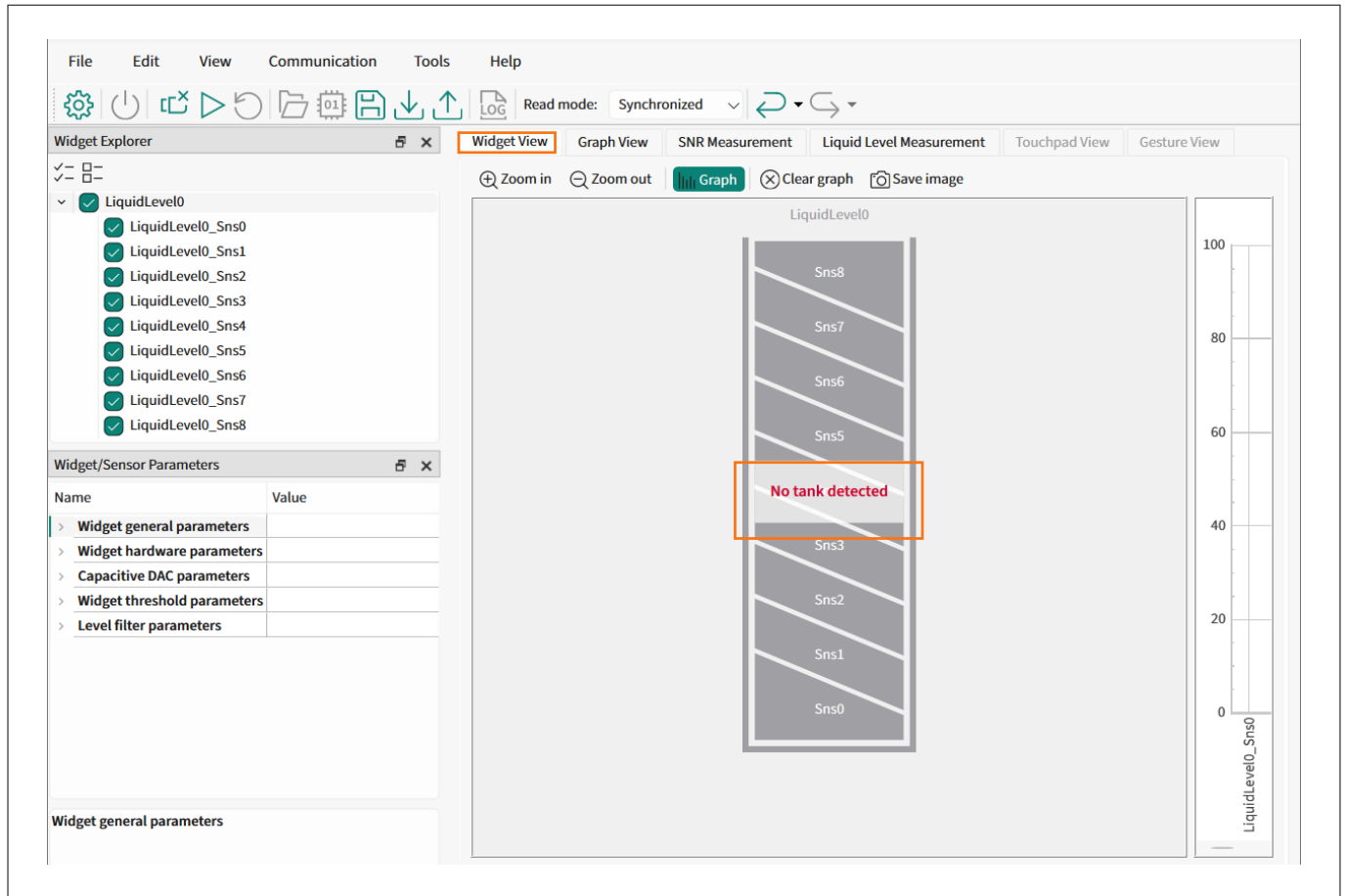

**Figure 19** No tank indication in CAPSENSE™ Tuner

**Note:** Enabling or disabling the tank removal detection feature will not impact the device's functionality and it will not require collecting calibration data again.

### 6.4 Liquid presence detection

The Liquid Presence detection feature is a functionality that reports the presence of a liquid, based on a per-configured threshold. This feature can be enabled using either the **Liquid Level widget** or the **Liquid Presence widget**.

Liquid level calibration procedure remains same for both widgets as outlined in the [Liquid-level calibration procedure](#) section.

The **Liquid Presence widget** is a dedicated widget designed for liquid presence detection with three electrodes, which is suitable for applications where high resolution is not required, and to detect states, such as empty, full, or half-filled tanks. [Figure 20](#) shows the Liquid Presence widget view in CAPSENSE™ Tuner.

## 6 Liquid-level features

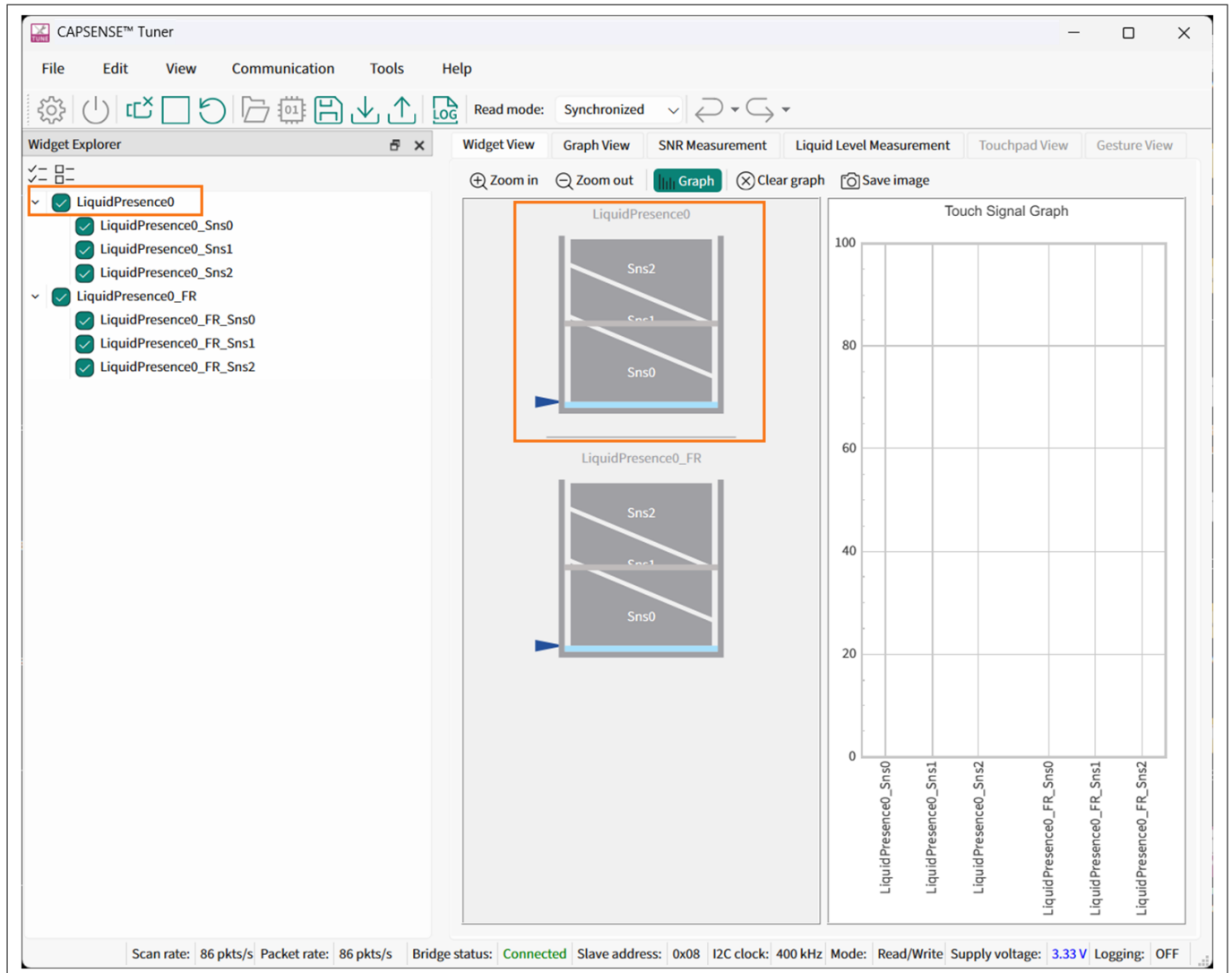

**Figure 20** Liquid presence widget view of the CAPSENSE™ Tuner

### 6.4.1 Enabling liquid presence feature

To enable the liquid presence detection feature, configure two key parameters as [Figure 21](#) shows.

1. **Liquid presence:** This parameter sets the liquid level presence detection threshold
2. **Hysteresis:** Used along with the presence threshold parameter to define the liquid level presence state. The recommended value for hysteresis is the 10% of the presence threshold

6 Liquid-level features

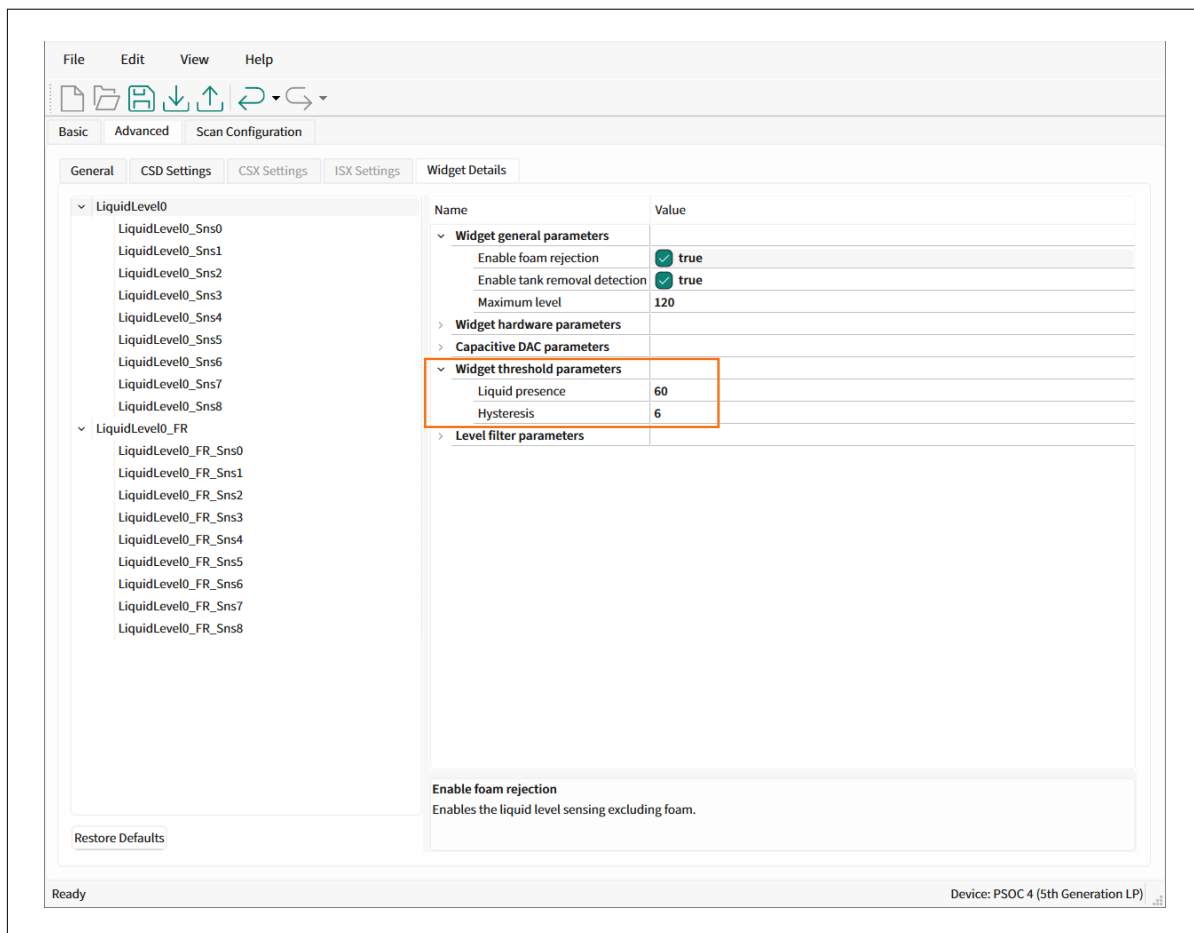

Figure 21 Liquid presence configuration parameters

6.4.2 Verification

After completing the calibration procedure and programming the device, you can observe the detection of liquid presence in the tuner as soon as the water level crosses the configured thresholds as Figure 22 shows.

6 Liquid-level features

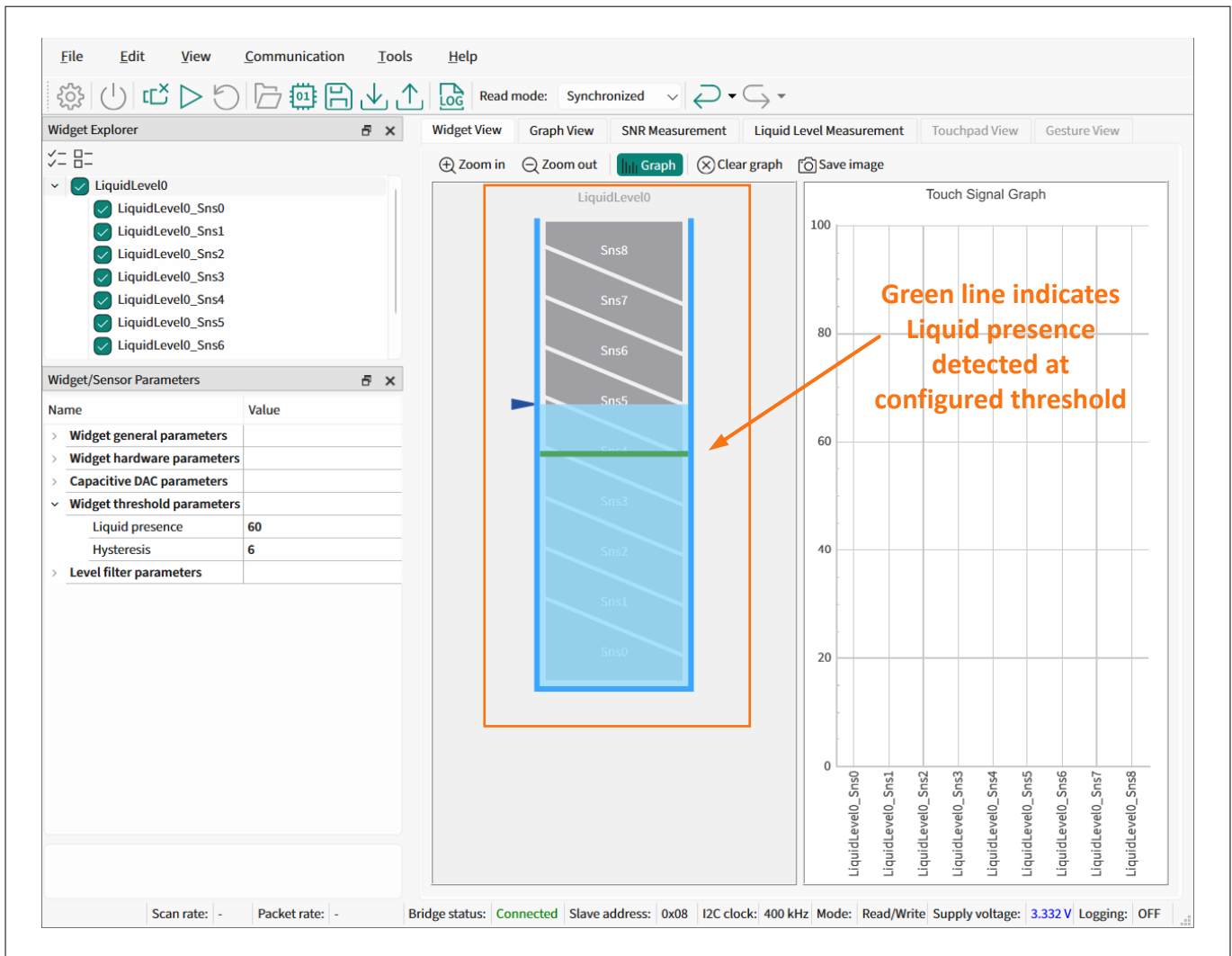

Figure 22 Liquid presence indication in CAPSENSE™ Tuner

6.5 One-time factory auto-calibration

The CAPSENSE™ based liquid-level sensing (LLS) system utilizes frozen CDAC values to train the Machine Learning (ML) model for level measurement. However, using the same frozen CDAC values across different parts can affect the system's performance because they can vary across devices and sensing setups. To account for these variations, it is recommended to perform a one-time factory auto-calibration.

**Need for one-time auto-calibration**

This calibration helps to avoid part-to-part variation on tank, and device, which can impact the accuracy of the measurements.

**Recommendation**

The recommendation is to perform a one-time factory auto-calibration for each device with the **empty** tank attached. This calibration will be performed automatically during the initial power-on sequence after flashing and the resulting calibrated CDAC values will be saved in the flash memory.

**Note:** *It is essential to completely empty the tank before programming to ensure accurate one-time factory auto-calibration.*

The one-time calibration can be performed in the application-level by following the steps from the flowchart as shown in Figure 23.

## 6 Liquid-level features

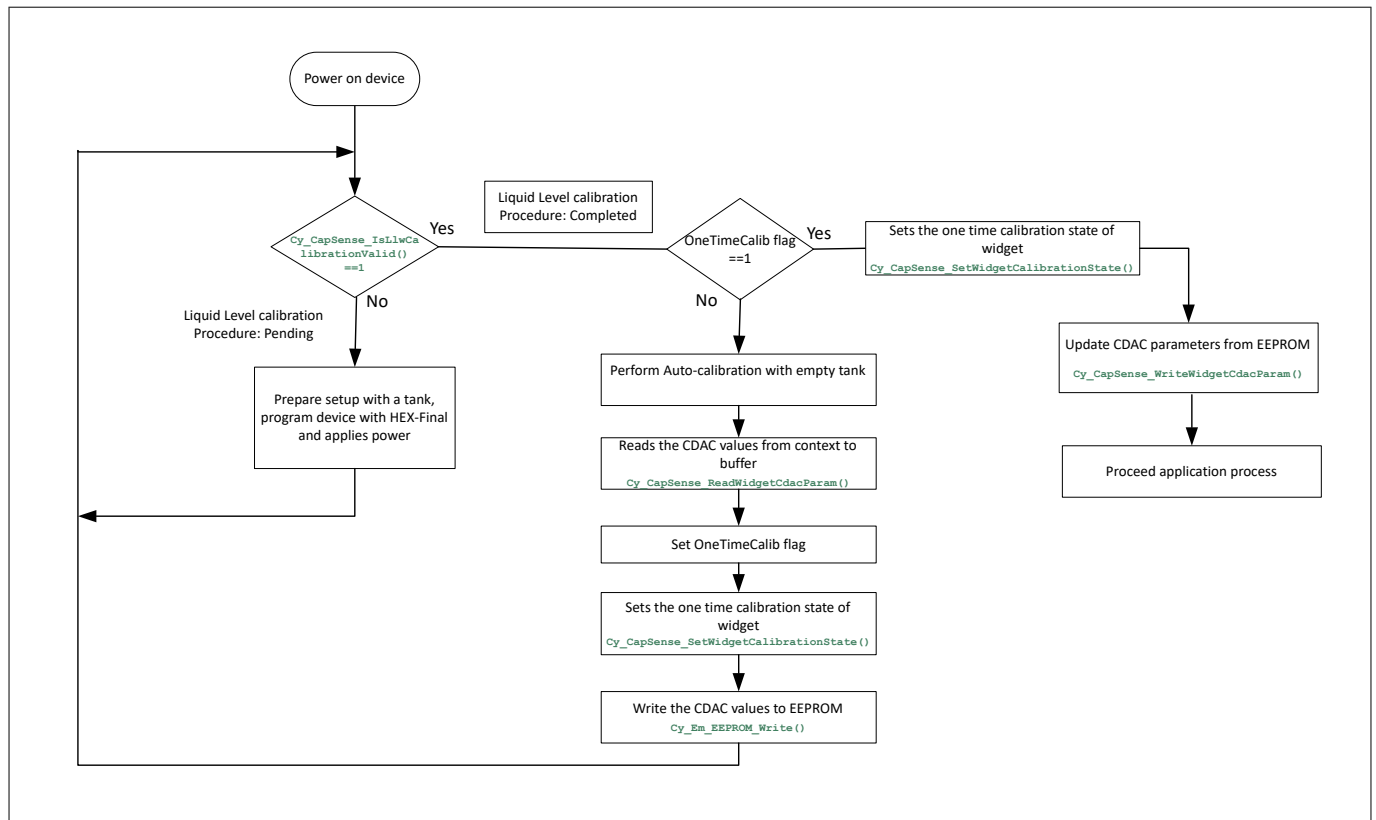

**Figure 23 One-time factory auto-calibration flow**

For detailed implementation of the one-time factory auto-calibration in firmware, see the [PSOC™ 4: MSCLP CAPSENSE™ liquid-level sensing](#) code example. Additionally, for the liquid level calibration procedure, see the [Liquid-level calibration procedure](#) section.

7 Liquid-level calibration procedure

7 Liquid-level calibration procedure

The liquid-level processing function must be calibrated for each design. The calibration routine increases the accuracy of the solution and is guided by the CAPSENSE™ Tuner tool. Before calibrating, ensure that the liquid-level sensors are properly tuned following the guidance in the “Tuning Procedure” section of [PSOC™ 4: MSCLP CAPSENSE™ liquid-level sensing](#) code example.

If the system requires foam rejection, ensure that the “Foam rejection” option is enabled in the project before calibrating.

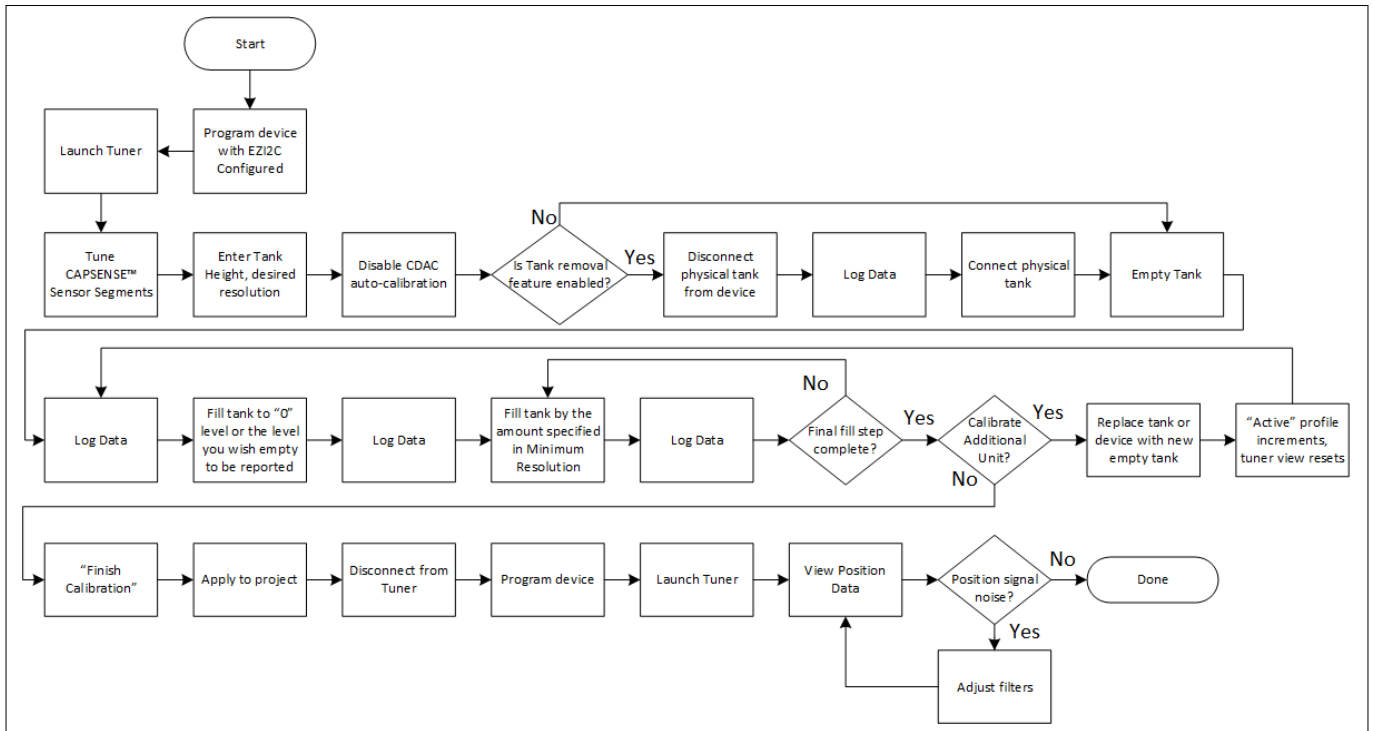

Figure 24 Liquid-level calibration procedure

**Note:** The calibration process involves repeated data logging exercises using various combinations of PSOC™ devices and water tanks, with each unique pairing of a device and tank being referred to as a distinct "Profile". For more details of the multi-profile option, see the [Multi-profile](#) section.

7.1 Level calibration

Prerequisites:

- Ensure that the sensor data can be read
- An additional foam rejection calibration process is required before the following mentioned liquid-level sensing sensor calibration process

Calibration procedure:

1. Navigate to the **Liquid Level Measurement** tab, as [Figure 25](#) shows

7 Liquid-level calibration procedure

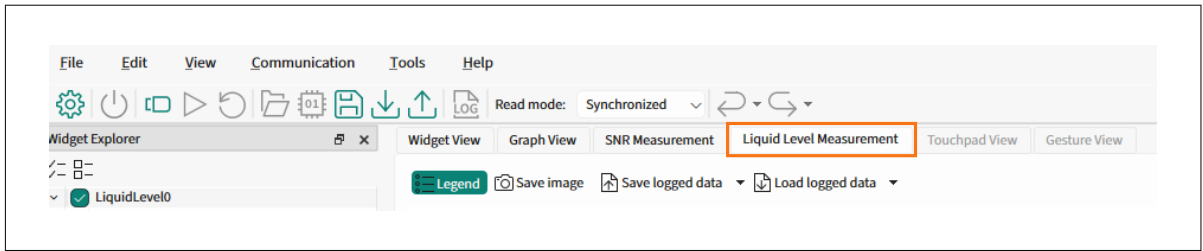

**Figure 25** Liquid Level Measurement tab in CAPSENSE™ Tuner

2. Follow the steps mentioned in **Sensor tuning** section as [Figure 26](#) shows

**Note:** Ensure to empty your tank entirely prior to performing this operation

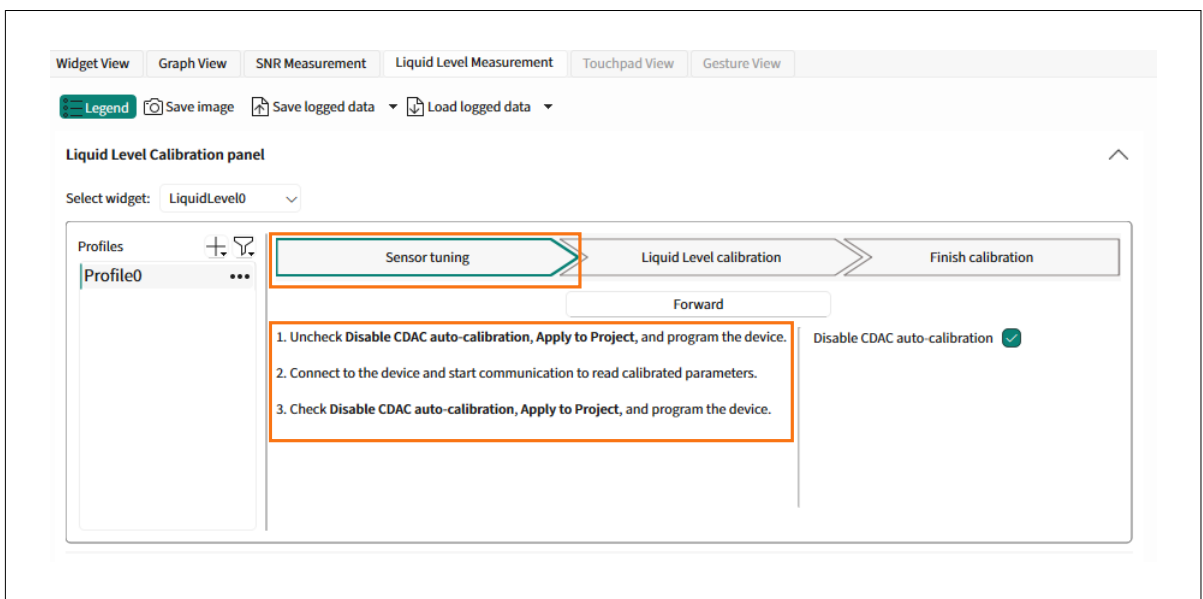

**Figure 26** Sensor tuning

3. This step is required if the foam rejection is enabled, else go to **Step 4**.

- a. **Enter Tank Height:** The total height of the liquid that is to be measured in mm
- b. Keep the tank empty and click **Log data**

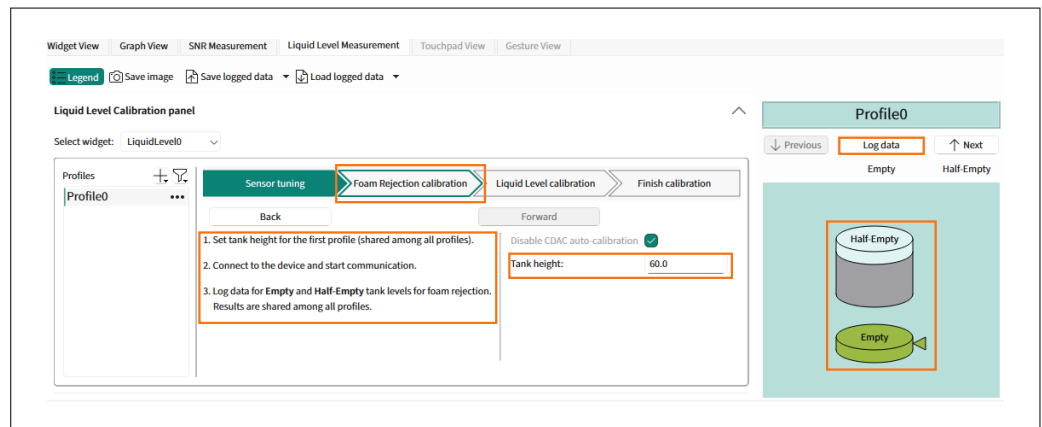

**Figure 27** Empty tank calibration for foam rejection

c. Fill the tank until it is half full, verify you are in the **Half-Empty** step and then click **Log data** again

7 Liquid-level calibration procedure

**Note:** *If you re-calibrate the foam rejection data, all existing liquid level calibration data for all profiles will be invalidated. In this case, it is mandatory to re-log the liquid level data*

4. Enter the measurement parameters for your tank, as [Figure 28](#) shows

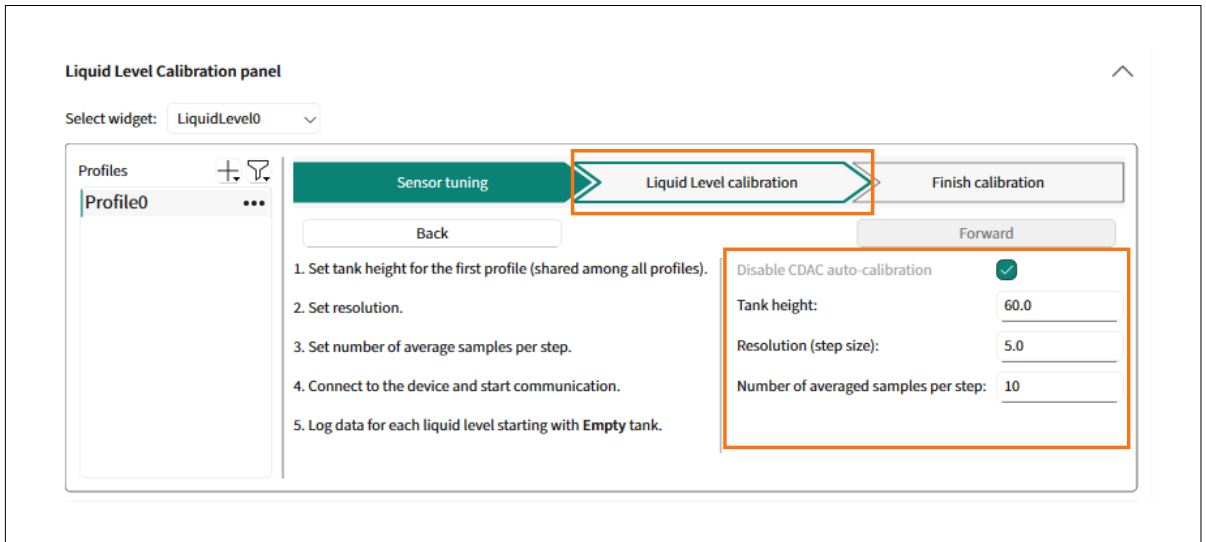

**Figure 28** Liquid-level measurement parameters

- **Tank Height:** The total height of the liquid that is to be measured in mm
- **Resolution (step size):** The minimum change in liquid depth you would like to measure  
Note that the amount of calibration data you need to collect is inversely proportional to this value. Lower minimum resolution values yield more data collection
- **Number of averaged samples per step:** The number of raw counts samples that are averaged to yield one data point while logging data. Higher values increase data logging time and accuracy

**Note:** *If the foam rejection is enabled, the **resolution (step size)** and the **number of averaged samples per step** fields will become editable only after the **Step 3** of this section is completed*

5. Log data:

- Skip this step if **Enable tank removal detection** feature is disabled. This step is required only if the **Enable tank removal detection** feature is enabled as described in the [Tank removal detection](#) section
  1. Disconnect the physical tank from the device and verify you are on the **No tank** step and click **Log data**

## 7 Liquid-level calibration procedure

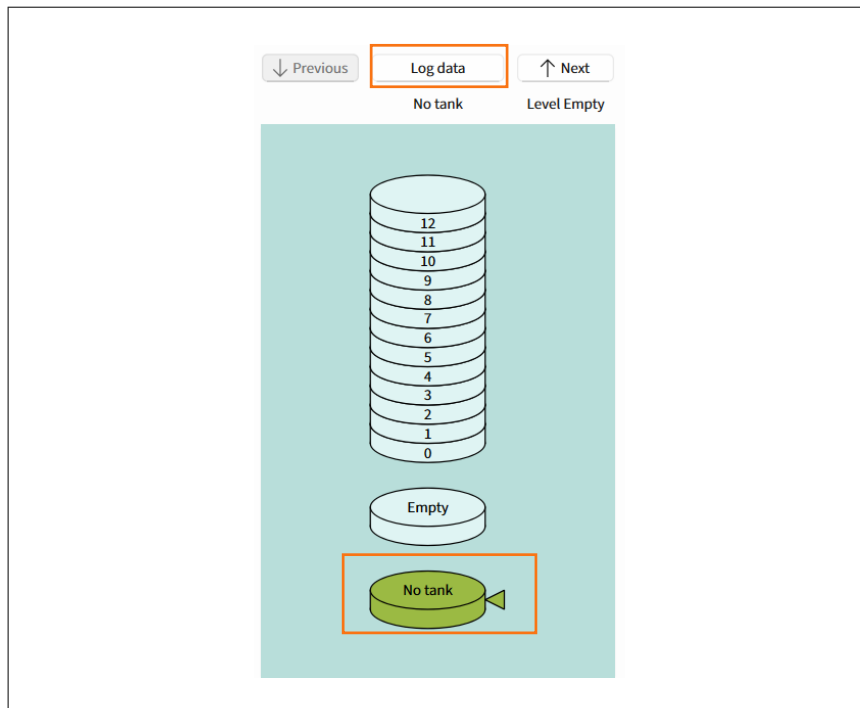

**Figure 29** Logging data for the "No tank" step

2. Connect the physical tank with the device
- b.** Empty the tank completely and verify you are on the **Empty** step. Then click **Log data**
- The **Empty** step becomes dark green, as [Figure 30](#) shows
- The logging status of the levels is color-coded as follows:
- **Dark green:** Logged level
  - **Green:** Current level to log
  - **White:** Levels yet to be logged

7 Liquid-level calibration procedure

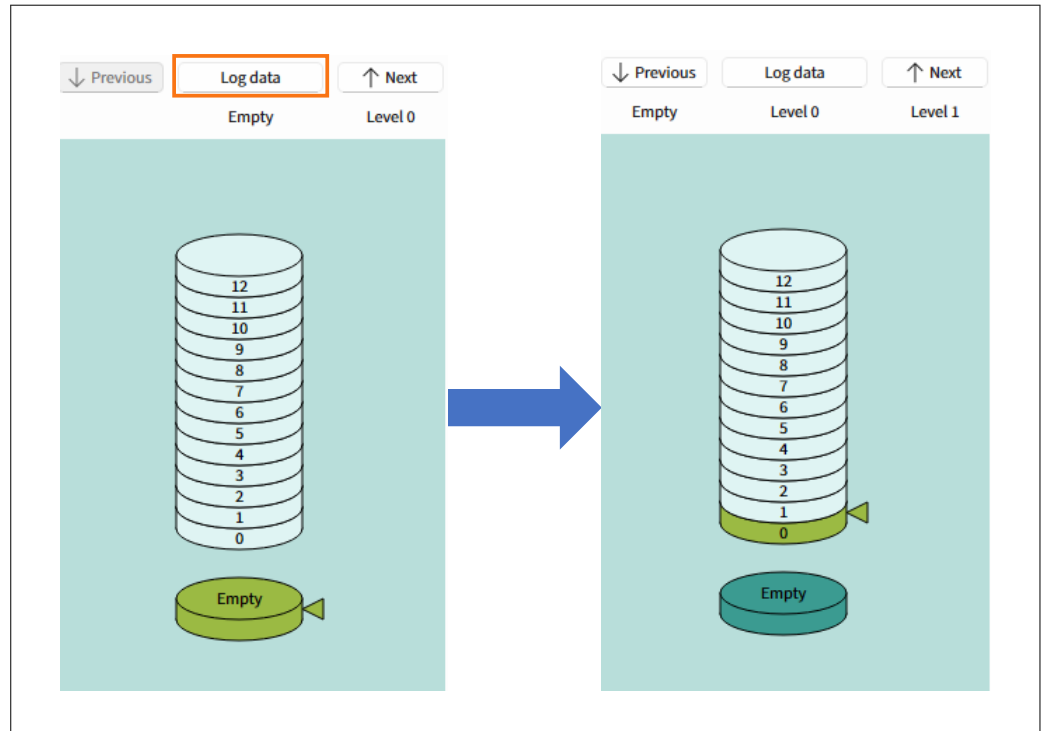

**Figure 30** Logging data for the "Empty" step

- c. Fill the tank to the level that should be considered empty; this is the '0' step. Wait a moment for the system to settle, then select **Log data**. Once logged, the color of level "0" changes from green to dark green

The addition of water introduces new capacitance and a temperature change that take a few seconds to settle. Wait for a few seconds before logging data, otherwise the system may not calibrate correctly

**Note:** *If the '0' step and the 'Empty' step are physically aligned at the same level, as shown in [Figure 31](#), leave the tank empty during this step. However, if the '0' step and the 'Empty' step are at different levels, as illustrated in [Figure 32](#), ensure that the tank is filled to the correct level for the '0' step.*

7 Liquid-level calibration procedure

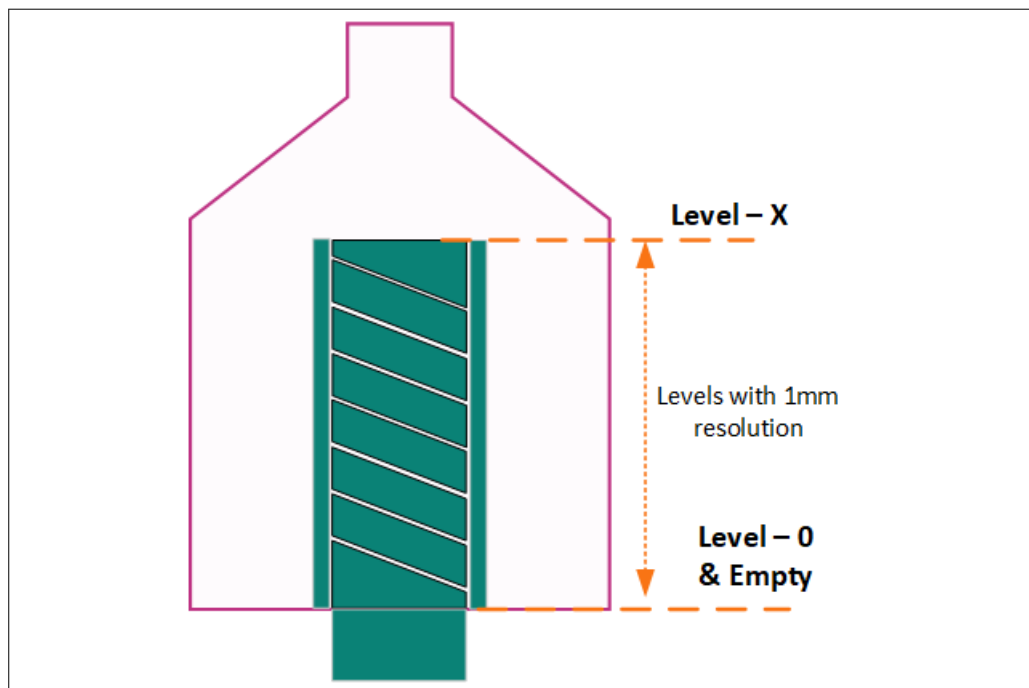

**Figure 31** Empty and Level-0 are the same

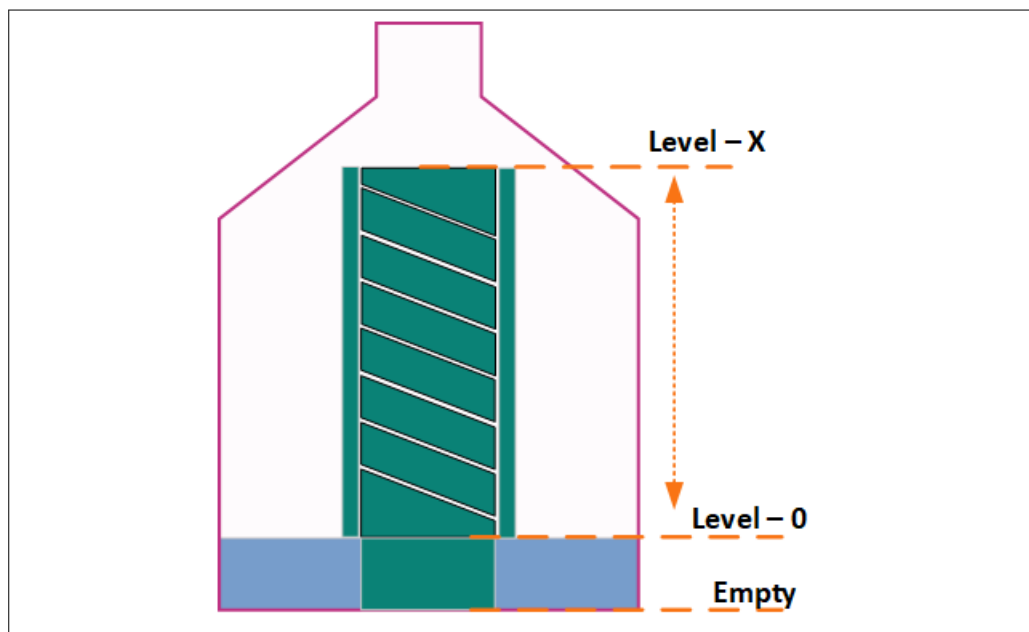

**Figure 32** Empty and Level-0 are different

- d. Verify you are on **height step 1** as shown in [Figure 33](#). Fill the tank to the level configured in **resolution (step size)**. Log the data

7 Liquid-level calibration procedure

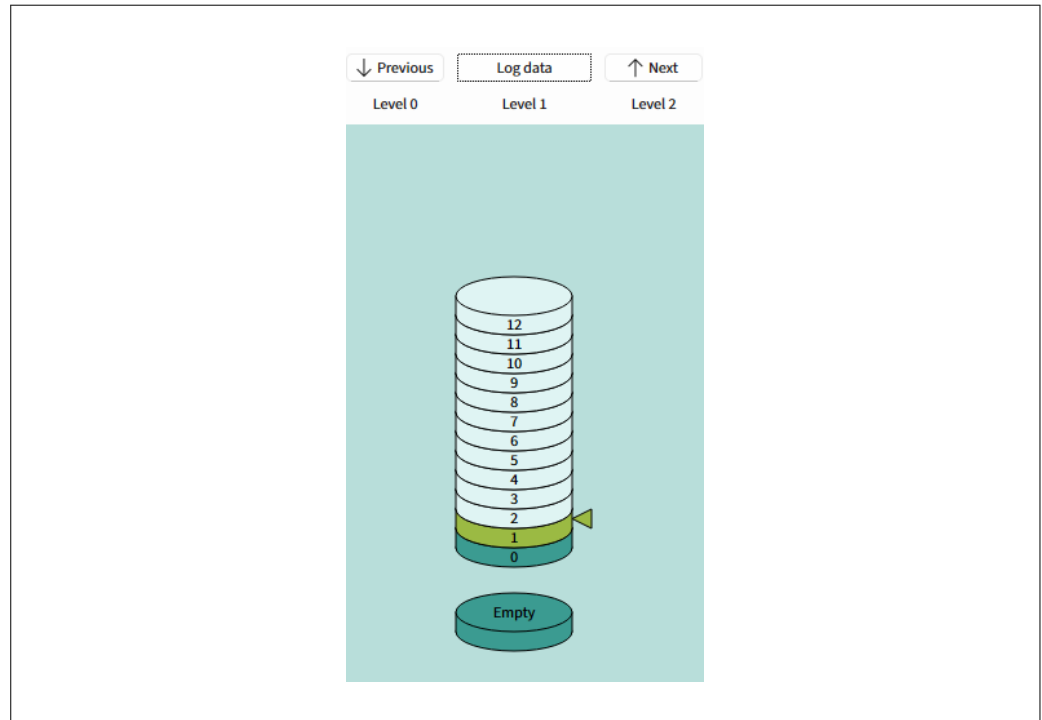

**Figure 33** Progress bar showing that the current step is 1

- e. For each subsequent step, fill the tank by the level indicated by **resolution** and log data Repeat until each step is complete (represented by a dark green color, as Figure 34 shows).

**Note:** You can skip steps by clicking **Next level**, which can reduce accuracy but reduces the total number of calibration steps needed  
 You can also return to any level by selecting **Previous level** any number of times or by clicking directly on the level in the progress bar

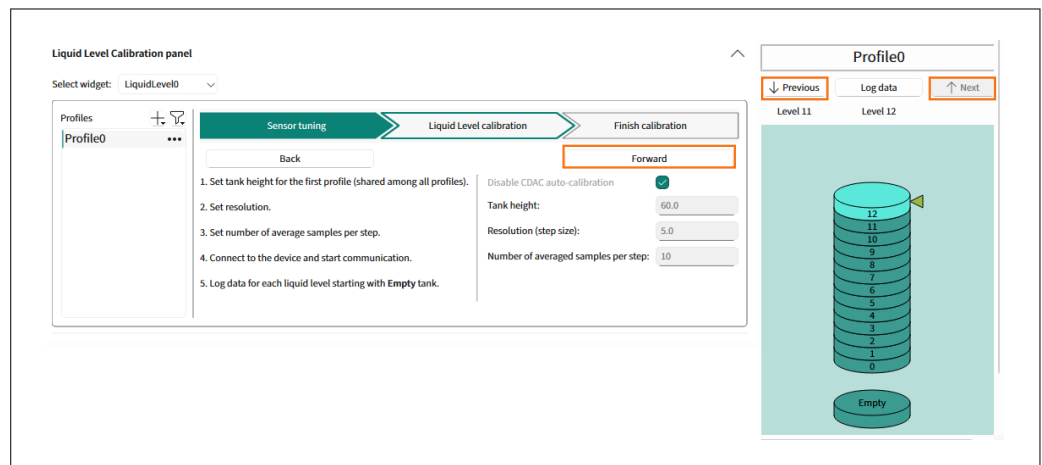

**Figure 34** Completed progress bar

- f. After data has been logged for the final step, select **Forward** and click **Start finish calibration** as Figure 35 shows

## 7 Liquid-level calibration procedure

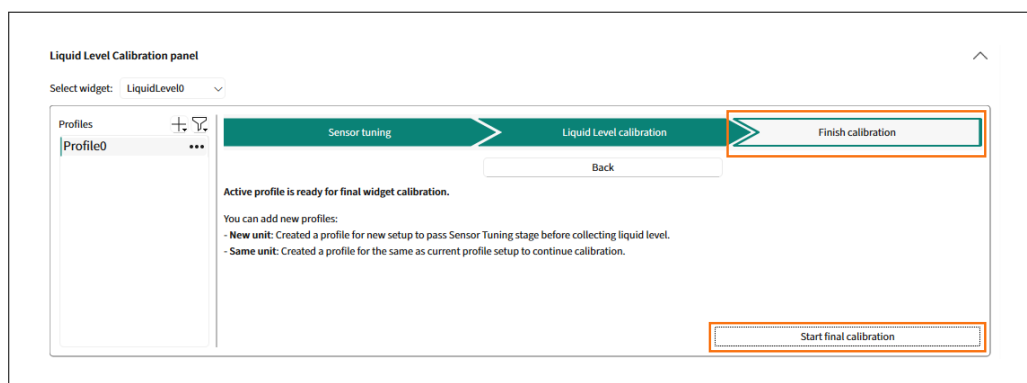

**Figure 35** Finish calibration

Select the profile that you want to use, as [Figure 36](#) shows.

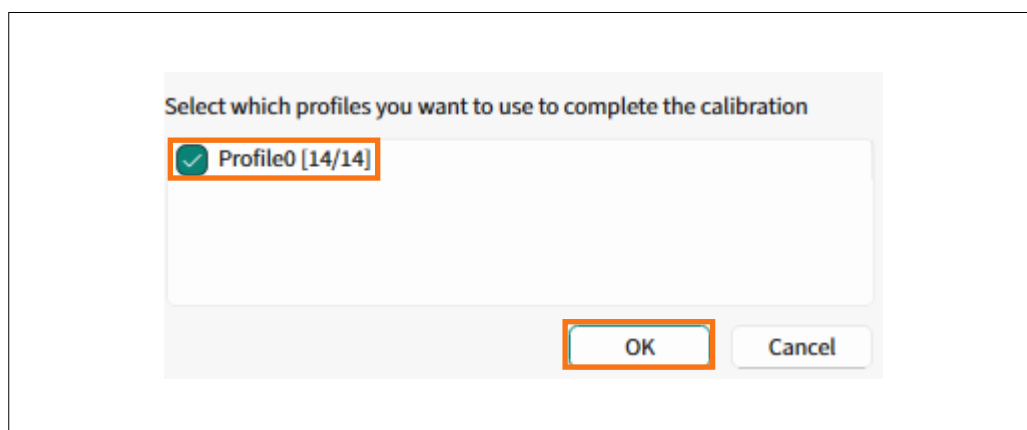

**Figure 36** Select profile

Wait for the calibration process to complete, as [Figure 37](#) shows

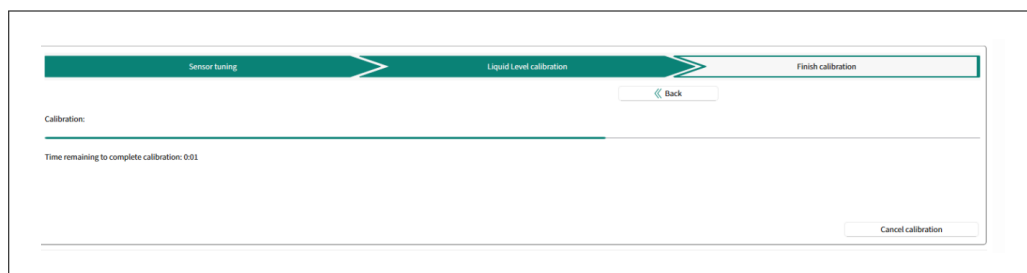
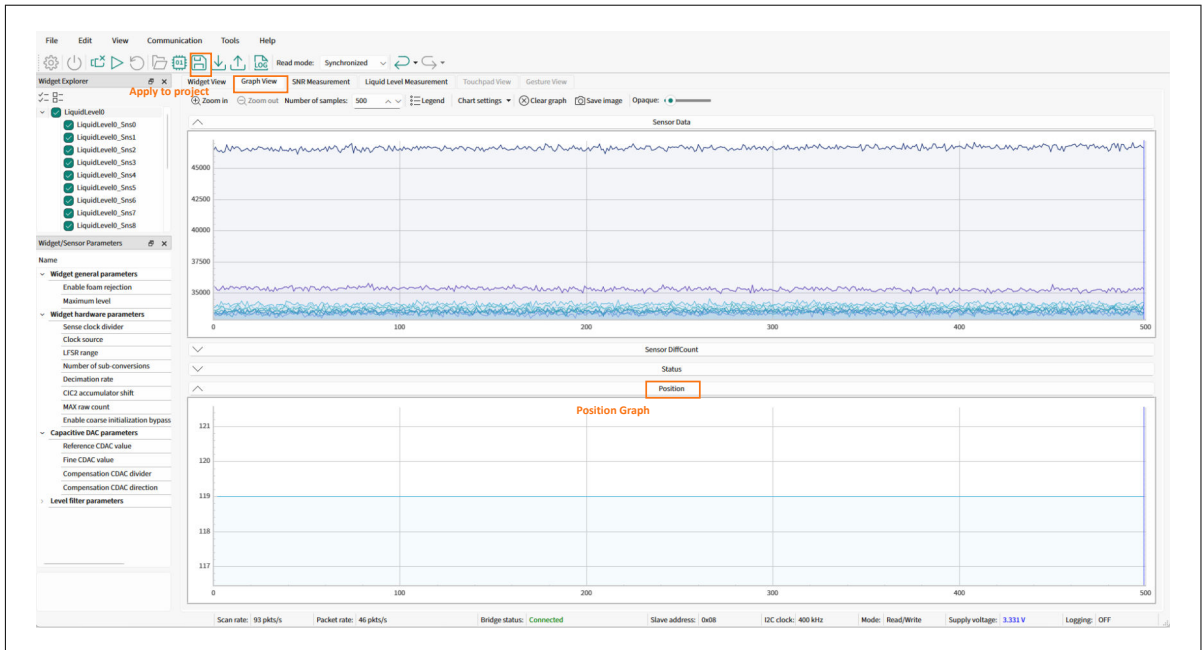

**Figure 37** progress bar

After the calibration is completed, new graphs are displayed, which show the accuracy and error of the calibration based on the input data that is logged in **Step 5**.

6. Select **Apply to Project**, then disconnect from the tuner, and empty the tank

7 Liquid-level calibration procedure



**Figure 38** Apply to project button and the Position graph

7. Program the part to apply the calibration to the device
8. Reconnect to the tuner and navigate to the **Graph View** tab  
Observe the liquid level displayed in the **Position** graph
9. Fill the tank by a known amount and check if the position closely matches the expected value
  - The expected position value is defined by [Equation 1](#):

$$Position = Position_{Max} \times \frac{Minimum\ resolution}{Tank\ height} \times LiquidLevel_{Current}$$

**Equation 1**

- **Position<sub>Max</sub>**: The liquid-level sensor widget’s maximum level parameter
  - **Minimum resolution**: Minimum resolution set in the tuner
  - **Tank height**: Tank height value set in the tuner
  - **LiquidLevelCurrent**: The current level of liquid present in the container
    - If the position is not accurate, re-calibrate your system following the procedure in **Step 4**.
10. If the noise levels in the position output are not acceptable, for example as [Figure 39](#) shows, configure the software filters for your system in **CAPSENSE™ Configurator**:

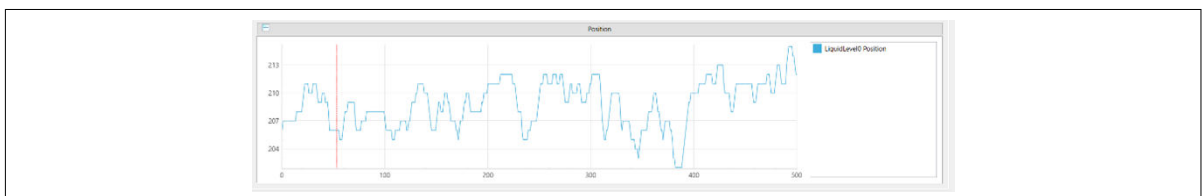

**Figure 39** Jittery position output

- a. Disconnect from CAPSENSE™ Tuner and open **CAPSENSE™ Configurator**

7 Liquid-level calibration procedure

- b. Enable raw count filtering as shown in **Step 4**. of “Fine tune for required SNR” in [PSOC™ 4: MSCLP CAPSENSE™ liquid-level sensing](#) code example. Oftentimes, raw count filtering is enough to reduce toggling and position noise
- c. Enable **Position** filters. Navigate to **Advanced > Widget Details > LiquidLevel0 widget > Level filter parameters** and configure the filters as needed, as [Figure 40](#) shows

**Table 1 Raw count filters and its functions**

Name	Function
IIR filter	Programmable filter that behaves as a low-pass filter. Lower coefficient values have a lower cutoff-frequency and reduce response time
Median filter	Averages three samples to remove noise spikes
Average filter	Averages two samples to remove periodic noise
Jitter filter	Eliminates toggling noise

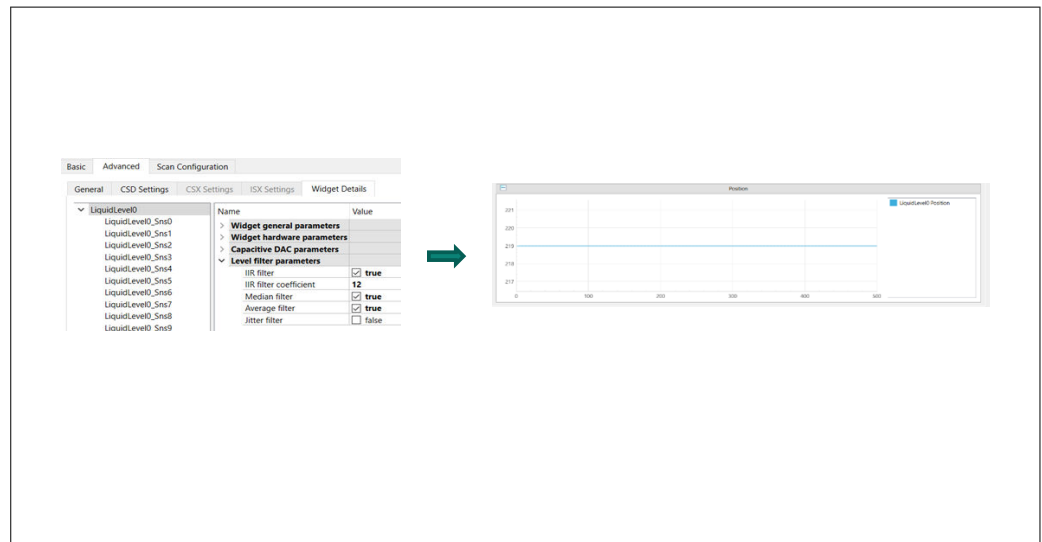

**Figure 40 Enabling level filters in CAPSENSE™ Configurator and the clean position signal observed**

- 11. If you are utilizing the form rejection method, see the [Foam rejection coefficient calculation](#) section to update the form rejection coefficient accordingly

**7.2 Foam rejection coefficient calculation**

The foam rejection widget contains an additional parameter, the foam correction coefficient that determines how much compensation is applied to the level detection to remove signal from the foam.

The foam correction coefficient is given by the following equation:

$$Coeff_{foam} = 256 \times \frac{Level_{Foam} - Level_{known}}{Level_{liquid} - Level_{foam}}$$

**Equation 2**

- Level<sub>Foam</sub> = The level displayed by the CAPSENSE™ Tuner for the foam rejection widget
- Level<sub>known</sub> = The level of the target liquid known by measurement with an external tool
- Level<sub>Liquid</sub> = The level displayed by the CAPSENSE™ Tuner for the base liquid-level widget

## 7 Liquid-level calibration procedure

To calculate the foam correction coefficient, ensure that you have correctly followed the process detailed in [Level calibration](#). Then, perform the following steps:

1. Fill your tank to a known target level without adding any surfactants
2. Add a surfactant (soap, cleaner detergent, or other bubbly liquid) and vigorously stir the mixture to generate a layer of bubbles on the surface of the liquid
3. In CAPSENSE™ Tuner, connect, start, and navigate to the **Position** graph tab
4. Enable both the base liquid-level widget and the foam rejection widget and view the level data, as [Figure 41](#) shows

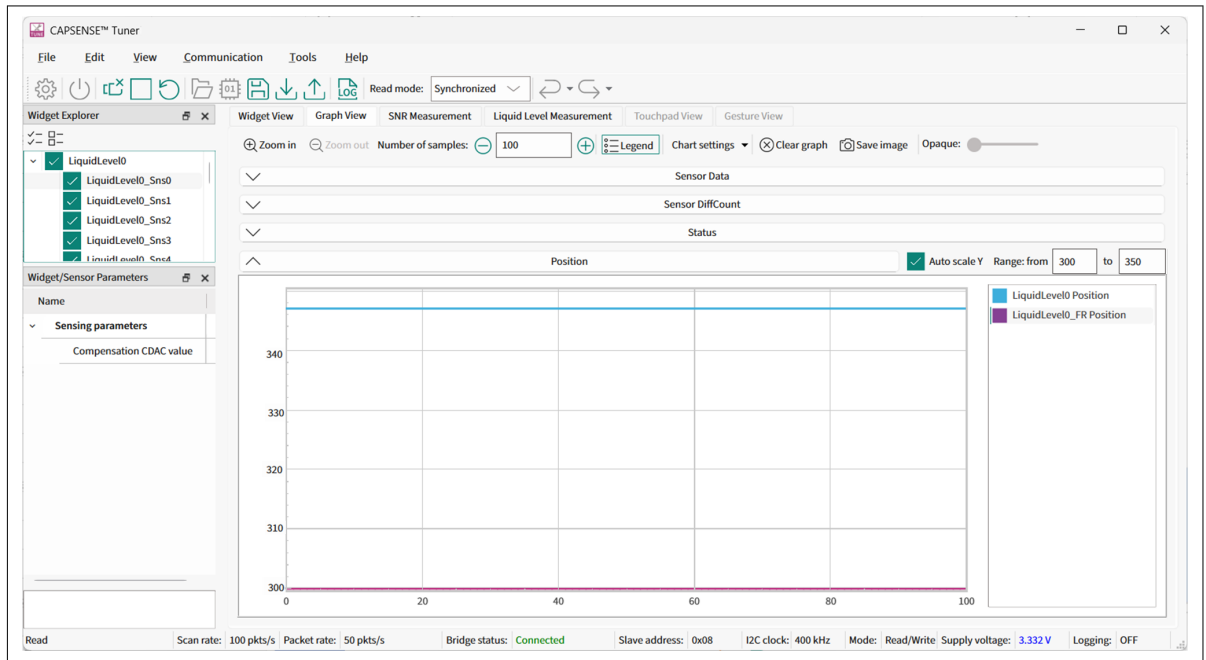
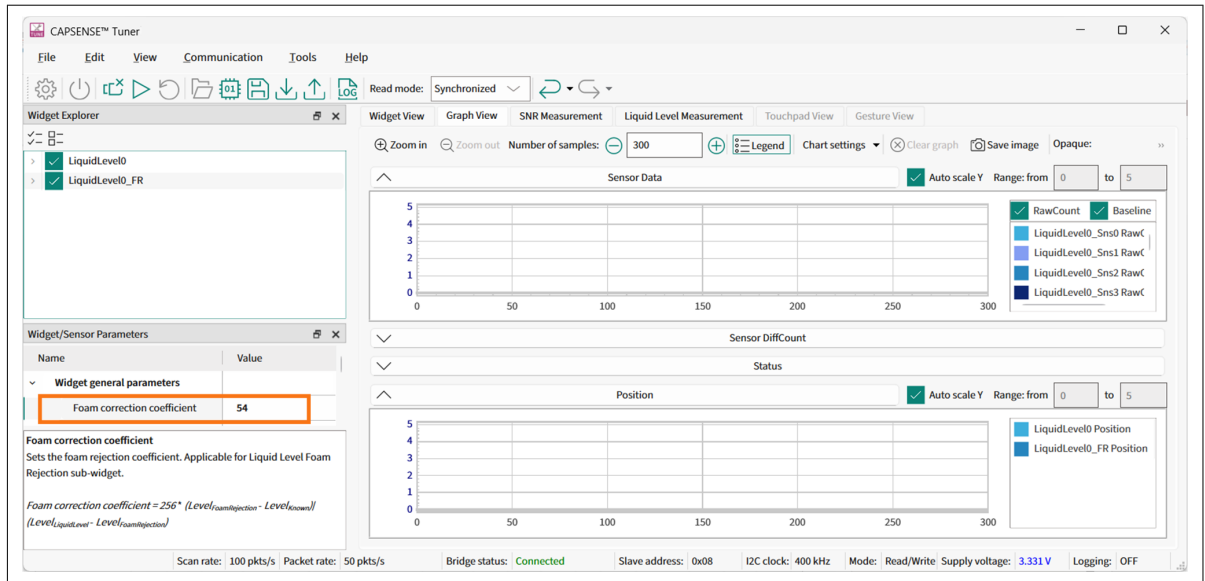

**Figure 41** Tuner data showing the position of the liquid-level base widget (blue); foam rejection enabled widget (purple)

In the example, in [Figure 42](#), the calculated **Foam correction Coefficient** is as follows:

- $Level_{Foam} = 300$ ,  $Level_{Known} = 290$ ,  $Level_{Liquid} = 347$ ,  $Coeff_{foam} = 54$
5. Change the **Foam correction Coefficient** in the widget and apply the change to your device and project

## 7 Liquid-level calibration procedure



**Figure 42** Foam correction coefficient widget in CAPSENSE™ Tuner

6. Ensure that the position value for the FR widget now matches the actual level of liquid

---

## References

## References

### Supported devices

- [1] Infineon Technologies AG: *PSOC™ 4000T webpage*; [Available online](#)
- [2] Infineon Technologies AG: *PSOC™ 4100T Plus webpage*; [Available online](#)

### Supported kits

- [3] Infineon Technologies AG: *CY8CPROTO-040T-MS: PSOC™ 4000T Multi-Sense Prototyping Kit*; [Available online](#)
- [4] Infineon Technologies AG: *CY8CPROTO-041TP: PSOC™ 4100T Plus Prototyping Kit*; [Available online](#)

### Related resources

- [5] Infineon Technologies AG: *CAPSENSE™ sensing controller webpage*; [Available online](#)
- [6] Infineon Technologies AG: *ModusToolbox™ software*; [Available online](#)
- [7] Infineon Technologies AG: *ModusToolbox™ software on GitHub*; [Available online](#)
- [8] Infineon Technologies AG: *Eclipse IDE for ModusToolbox™ user guide*; [Available online](#)
- [9] Infineon Technologies AG: *ModusToolbox™ CAPSENSE™ Configurator user guide*; [Available online](#)
- [10] Infineon Technologies AG: *ModusToolbox™ CAPSENSE™ Tuner user guide*; [Available online](#)
- [11] Infineon Technologies AG: *CAPSENSE™ Middleware Library*; [Available online](#)
- [12] Infineon Technologies AG: *AN64846 – Getting started with CAPSENSE™*; [Available online](#)
- [13] Infineon Technologies AG: *AN79953 – Getting started with PSOC™ 4 MCU*; [Available online](#)
- [14] Infineon Technologies AG: *AN85951 – PSOC™ 4 and PSOC™ 6 CAPSENSE™ design guide*; [Available online](#)

---

**Revision history**
**Revision history**

Document revision	Date	Description of changes
**	2024-06-25	Initial release
*A	2024-12-09	Updated the sensor designer tool, images, and factory calibration process
*B	2025-01-10	Updated GitHub link of the CE
*C	2025-02-14	Updated Foam Rejection Calibration Process
*D	2025-03-21	Template update Updated the <a href="#">Supported devices</a> and <a href="#">Supported kits</a> Updated the following figures: <a href="#">Figure 1</a> <a href="#">Figure 9</a> <a href="#">Figure 34</a> <a href="#">Figure 38</a> <a href="#">Figure 42</a>
*E	2025-10-08	Added <a href="#">One-time factory auto-calibration</a> , <a href="#">Multi-profile</a> sections and updated steps in <a href="#">Liquid-level calibration procedure</a>
*F	2025-12-16	Added support to include features: <a href="#">Tank removal detection</a> and <a href="#">Liquid presence detection</a> Updated <a href="#">Figure 24</a> Updated <a href="#">Level calibration</a>
*G	2026-04-28	Added the following sections: <ul style="list-style-type: none"> <li>• High-temperature validation results</li> <li>• Performance sensitivity to air gap variations</li> <li>• Foam rejection</li> </ul> Updated <a href="#">Figure 2</a> , <a href="#">Figure 5</a> , <a href="#">Figure 40</a> , and <a href="#">Figure 41</a>

---

## Trademarks

### Trademarks

PSOC™, formerly known as PSoC™, is a trademark of Infineon Technologies. Any references to PSoC™ in this document or others shall be deemed to refer to PSOC™.

## Trademarks

All referenced product or service names and trademarks are the property of their respective owners.

**Edition 2026-04-28**

**Published by**

**Infineon Technologies AG**

**81726 Munich, Germany**

**© 2026 Infineon Technologies AG**

**All Rights Reserved.**

**Do you have a question about any aspect of this document?**

**Email: [erratum@infineon.com](mailto:erratum@infineon.com)**

**Document reference**

**IFX-hku1741084300032**

## Important notice

The information contained in this application note is given as a hint for the implementation of the product only and shall in no event be regarded as a description or warranty of a certain functionality, condition or quality of the product. Before implementation of the product, the recipient of this application note must verify any function and other technical information given herein in the real application. Infineon Technologies hereby disclaims any and all warranties and liabilities of any kind (including without limitation warranties of non-infringement of intellectual property rights of any third party) with respect to any and all information given in this application note.

The data contained in this document is exclusively intended for technically trained staff. It is the responsibility of customer's technical departments to evaluate the suitability of the product for the intended application and the completeness of the product information given in this document with respect to such application.

## Warnings

Due to technical requirements products may contain dangerous substances. For information on the types in question please contact your nearest Infineon Technologies office.

Except as otherwise explicitly approved by Infineon Technologies in a written document signed by authorized representatives of Infineon Technologies, Infineon Technologies' products may not be used in any applications where a failure of the product or any consequences of the use thereof can reasonably be expected to result in personal injury.