

# FOC Motor Drive Application Kit

## Scalable Solution for Field Oriented Control (FOC)

THE KIT IS BUILT around the two novel Infineon MCU's, namely the XC878 and the XE164F MCU both capable of running Field Oriented Control (FOC).

Coming along with optimized motor control software as well as a digitally isolated real time monitoring tool, the kit offers an easy-to-use reference platform. The power stage is capable of driving a Permanent Magnet Synchronous Motors (PMSM).

The Application Kit is designed for the purpose of motor control trainings/ seminars and to evaluate the performance of real time capabilities of the Infineon microcontrollers. It offers designers a shorter time-to-market for energy efficient motor control designs targeting excellent torque dynamics, reduced noise and high system reliability.

### Benefit of FOC

Advanced motor control techniques are increasingly being used in consumer and industrial drives owing to the growing design focus on higher efficiency, better dynamic response and reduced audible noise. In order to enable rapid development of cost-effective designs, Infineon offers a new FOC Motor Drive Application Kit.

### Complete Software Package Including

- Easy motor parameter configuration
- DriveMonitor - Graphical User Interface for real time control and monitoring
- Optimized sensorless FOC source code for PMSM
  - Speed PI controller
  - Two current PI controller (Id and Iq)
- Source code for V/f control for ACIM for quick evaluation
- Free tool chain and IDE
- Fast flash programming via JTAG

### Ordering Code

- KIT\_AK\_FOCDRIVE\_V1

### Key Features

- Scalable 3-phase inverter
- Power board 23V - 56V, 7.5A
- PMSM motor and plug in power supply 24V
- XC878 (8-bit) with 16-bit arithmetic based MCU drive card capable of running FOC
- XE164 (16-bit) based MCU drive card capable of running FOC
- Software packages: FOC and V/f for XC878 and XE164
- Fully integrated switch mode power supply
- Integrated protection features for high system reliability
- Digital isolated real time monitoring tool
- Compiler and debugger
- Using Infineon 6ED003L06 gate driver, BSC196N10 MOSFETs, CoolSET ICE3B0565 power supply and TLE 4264 LDO

### Applications

- PMSM motors in:
  - Washing machines
  - Refrigerators
  - Industrial drives
  - Servo drives
  - Electrical power steering
  - Electric vehicle traction drive
  - Air conditioning
  - Fans, blowers
  - Pumps



# FOC Motor Drive Application Kit

## Scalable Solution for Field Oriented Control (FOC)

Scalable Motor Control Solutions using XC800 and XE166 Families

XC866-1FR	XC866-2/4FR	XC886/888 → Vector Computer	XC878 → Enhanced Vector Computer	XE164 → MAC Unit
PWM Unit with Hall Sensor	PWM Unit with Hall Sensor	PWM Unit triggers ADC	Two PWM Units trigger ADC	Three PWM Units trigger two ADC Units
Block Commutation	Block Commutation	Field Oriented Control sensorless	Field Oriented Control sensorless + digital PFC	Dual Motor Field Oriented Control sensorless + digital PFC

### 8-bit MCU XC878

- Cost-effective 8-bit μCs with 16-bit motor-control performance
- Built-in vector computer for Field Oriented Control
- Powerful motor control peripheral set: CAPCOM6 and 10-bit ADC
- Up to 64kB Flash
- Up to 3kB RAM
- LQFP-64

### 16-bit MCU XE164F

- High performance 16-bit μCs with MAC unit supporting single cycle 16 x 16bit multiplication and add
- Powerful motor control peripheral set
- 3x CAPCOM6 modules
- 2x 10-bit ADC modules
- Up to 768kB Flash
- Up to 82kB RAM
- LQFP-100

### Application Board

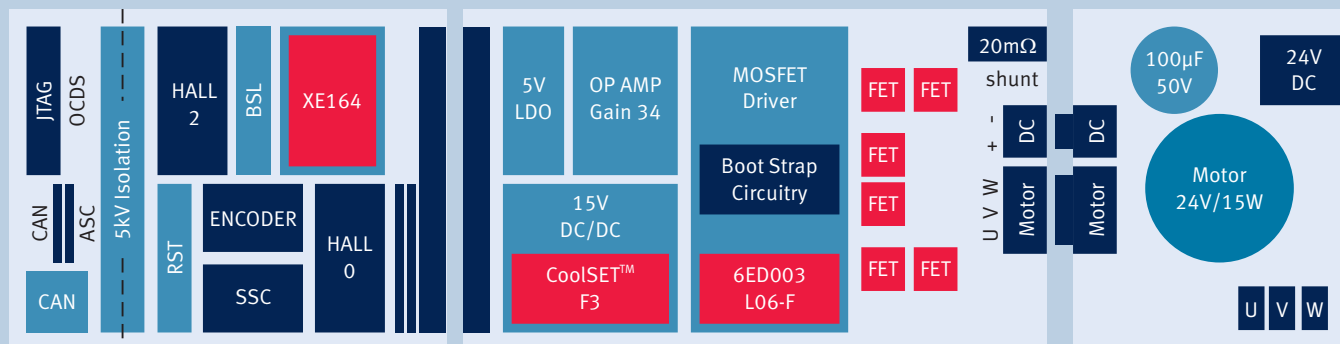

How to reach us:  
<http://www.infineon.com>

Published by  
Infineon Technologies AG  
81726 Munich, Germany

© 2009 Infineon Technologies AG  
All Rights Reserved.

**Legal Disclaimer** The information given in this Product Brief shall in no event be regarded as a guarantee of conditions or characteristics. With respect to any examples or hints given herein, any typical values stated herein and/or any information regarding the application of the device, Infineon Technologies hereby disclaims any and all warranties and liabilities of any kind, including without limitation, warranties of non-infringement of intellectual property rights of any third party.

**Information** For further information on technology, delivery terms and conditions and prices, please contact the nearest Infineon Technologies Office ([www.infineon.com](http://www.infineon.com)).

**Warnings** Due to technical requirements, components may contain dangerous substances. For information on the types in question, please contact the nearest Infineon Technologies Office. Infineon Technologies components may be used in life-support devices or systems only with the express written approval of Infineon Technologies, if a failure of such components can reasonably be expected to cause the failure of that life-support device or system or to affect the safety or effectiveness of that device or system. Life support devices or systems are intended to be implanted in the human body or to support and/or maintain and sustain and/or protect human life. If they fail, it is reasonable to assume that the health of the user or other persons may be endangered.