



LED lighting

Semiconductors for power conversion and smart lighting

www.infineon.com/lighting



Contents

Introduction	3	LED strips and signage	31
LED drivers	5	Linear LED driver ICs	32
Mixed-signal PFC and flyback controllers	6	Very low-cost LED driver ICs	33
ICL8800/ICL8810/ICL8820	6	BCR401W/BCR402W	33
BSS126I	7	Low-voltage-drop LED driver ICs	34
IRS2982S	8	BCR430U/BCR431U	34
IRS2505L	9	Robust LED driver ICs	35
ICE2PCS0XG/ICE3PCS0XG	10	BCR320U/BCR420U	35
SiC diodes for high-power applications	11	BCR401U/BCR402U/BCR405U	36
Digital flyback controllers	12	Radar sensors for smart lighting	37
XDPL8105	12	Radar sensors for presence detection and more	37
XDPL8210	13	Radar partner ecosystem at a glance including design house partners	38
XDPL8219	14	Our partners	39
XDPL8221	15	Wi-Fi module partner solutions	42
PFC plus half-bridge resonant controllers	16	Bluetooth Mesh	43
ICL5102	16	Bluetooth Mesh integrated module solutions	44
ICL5102HV	17	Bluetooth Mesh Internet gateway	44
DC-DC buck converters and smart controllers	18	Wi-Fi	45
ILD8150	18	Wi-Fi module partner solutions	46
BCR601/BCR602	19	OPTIGA™ Trust M	47
BCR601	20	Turnkey security solution optimized for connected devices	47
IRS2982 for high-voltage buck	21		
CoolMOS™ – high-voltage MOSFETs	22		
950 V CoolMOS™ PFD7	23		
950 V CoolMOS™ P7	24		
800 V CoolMOS™ P7	25		
700 V CoolMOS™ P7	26		
600 V CoolMOS™ P7	27		
OptiMOS™ 5 – medium-voltage MOSFETs	28		
150 V OptiMOS™ 5 for synchronous rectification	29		
NFC IC for configuration	29		
NLM0010/NLM0011	29		
0–10 V dimming interface IC	30		
CDM10V	30		

Get ready for the next big thing in LED lighting

LED lights have become part of our daily lives, making a significant contribution to global efforts to reduce our carbon footprint. LED lights have already replaced most installations fitted with either inefficient light sources like incandescent lamps or even more efficient sources like HID lamps designed for extended operating hours. LED penetration has been incredibly rapid across applications such as tunnel and subway lighting and outdoor lighting.

Looking ahead, we will focus on:

- › High-power LED lighting, for instance in stadiums
- › Horticultural lighting to replace 1000 W HPS lamps
- › Office lighting to replace fluorescent lamps

Many may assume that these developments mark the end of the LED innovation journey. However, here at Infineon Technologies, we anticipate significant new momentum in the LED space – and we are set to help shape future developments.

All indicators show that current efforts are not sufficient to slow down global warming. Today, many LED installations are not equipped with any control technology. Many users are satisfied with the energy savings they have achieved thus far by converting their existing light sources to LEDs. However, looking to the future is set to change – driven by direct or indirect regulatory requirements and the resulting increase in taxes on energy consumption and CO₂ emissions.



Hakan Yilmazer
Head of Application
Marketing for Lighting

Widespread implementation of presence detectors would be an extremely effective way to reduce energy consumption significantly. These sensors have to meet more stringent demands than the current passive infrared sensors that can only detect very rough motion.

Another topic that is gaining more attention is the efficiency and dimming quality of LED drivers. Today, most users are happy with an efficiency rate of 88 percent for power conversion. However, this figure could be easily pushed far above 90 percent by changing the topology for power conversion.

Dimming is currently widely deployed in residential and hospitality lighting applications. Street lighting applications do not typically support dimming functionality. LED dimming can enable substantial power savings compared with previous light sources and extend the system's lifetime.

At Infineon Technologies, we are passionate about developing these exciting applications in collaboration with our customers and partners. Our ambition is to offer customized products and solutions to our customers to address the critical energy efficiency challenges facing society now and in the future.

We hope you will enjoy the new edition of our LED lighting brochure.



Lighting system overview

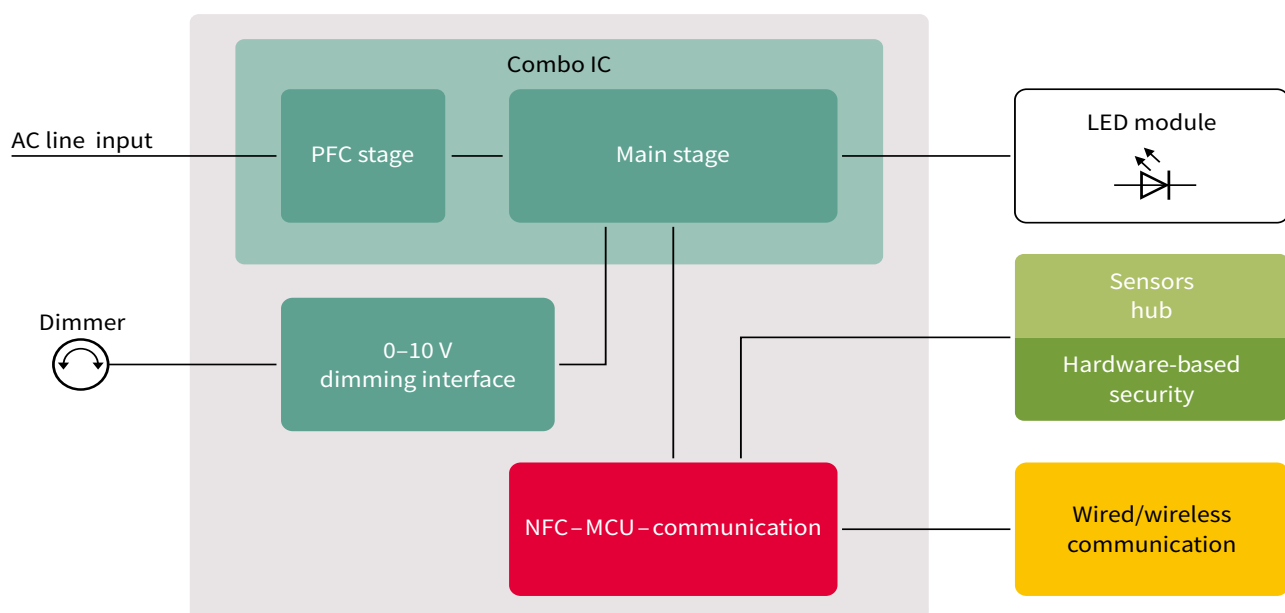



LED drivers

The type of LED drivers used in an LED lighting application has a significant impact on key system performance indicators such as:

- › Efficiency
- › Dimming capability
- › Power quality, i.e. PFC/THD
- › Light quality, i.e. ripple/flicker
- › Configurability of parameters, i.e. output current
- › Ability to support add-on features such as power monitoring
- › Product lifetime

System efficiency can be influenced by the choice of topology and the type of components used. A resonant topology, for instance, can increase LED driver efficiency by 4–5 percent. The right MOSFETs, a high-voltage start-up cell and synchronous rectification can also have a positive impact. Dimming down to 1 percent light output has become mainstream for indoor lighting .

Design strategies usually use analog dimming to a certain level and then switch to PWM dimming for lower levels. Many customers demand compliance with PFC and THD regulatory requirements at 50 percent dimming.

LED drivers based on a single-stage flyback topology usually have an output current ripple of ± 30 percent. Growing dissatisfaction with this ripple is fueling widespread adoption of two-stage topologies, i.e. single-stage PFC flyback combined with a secondary buck regulator.

To date, DIP switches have been typically deployed to configure the output current of LED drivers. The trend is now moving towards more elegant methods with LED driver manufacturers and lighting fixture makers opting for NFC technology, for example. Digital controllers with a digital interface such as UART enable designers to implement power monitoring at luminaire level.

Mixed-signal PFC and flyback controllers

ICL8800*/ICL8810*/ICL8820*

ICL88xx family of single-stage flyback controllers for constant voltage output is tailored for LED lighting applications to meet the required performance cost-effectively. They offer benchmarking performance for power factor correction and total harmonic distortion at full-load as well as at low-load conditions. Also, the controller's low standby power provides more margin for smart lighting systems that contain microcontrollers. The jitter function enables fulfillment of EMI requirements when the luminaire is foreseen to operate as an emergency luminaire.

Features ICL8800

- > Secondary-Side-Regulated (SSR) Constant Voltage (CV) output flyback controller
- > Depending on load condition, either quasi-resonant or discontinuous conduction mode with power factor correction applied

ICL8810 contains in addition

- > Active burst mode (ABM) to ensure low standby power

ICL8820 contains in addition

- > Jitter function

Benefits

- > Supporting wide load range and fast and stable reaction to dynamic load changes
- > $PF > 0.9$ and $THD < 10\%$ across a wide load range (AC input up to 277 Vrms)
- > Optimal efficiency, power factor and THD can be achieved by best-suited mode. In addition, DCM eases compliance with EMI at low-load condition

ICL8810 contains in addition

- > Very low standby power < 100 mW enables smart lighting in connection with microcontrollers

ICL8820 contains in addition

- > Jitter function enables fulfillment complying with EMI regulations in DC operation, i.e. usage of luminaire as emergency lighting

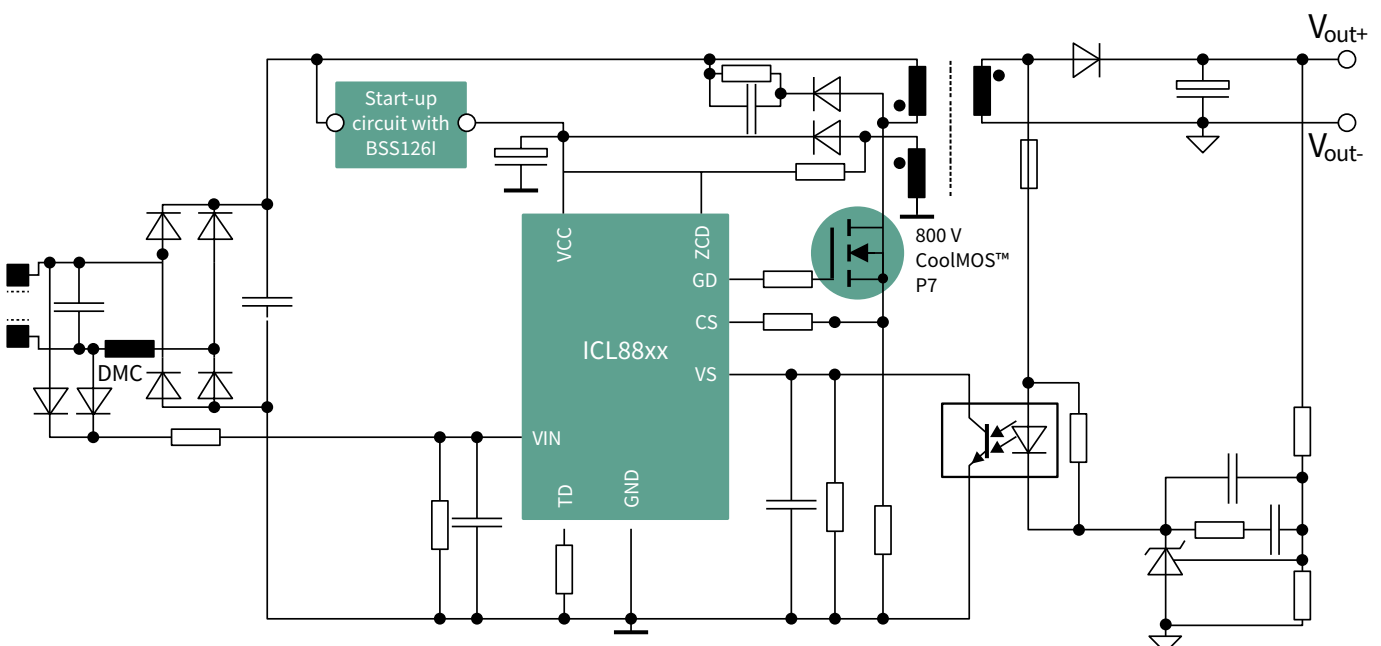

*Coming soon

Mixed-signal PFC and flyback controllers

BSS126I – High voltage start-up depletion MOSFET

The most elegant way of reducing the start-up time of an LED driver is the usage of ,normally-on‘ depletion-mode MOSFET. Solutions with start-up resistors consume power not only during the IC’s start-up also throughout the entire operation. In most implementations where the depletion-mode MOSFET is used, these are switched off after start-up.

Features

- > Normally-on device
- > Can be switched off after start-up
- > Requires very few external components
- > Small SOT-23 package

Benefits

- > Enables fast time-to-light < 500 ms
- > Higher system efficiency than start up resistor solutions
- > Increased system reliability due to lower thermal load
- > Helps fulfilling low system stand-by power requirements < 500 mW

Start-up current source

An external HV cell is preferred, e.g., designs with low standby power and no standby power.

With a depletion MOSFET, even at $V_{GS}=0$ V current will flow through the device. For a depletion MOSFET, a negative V_{GS} has to be applied to turn it off.

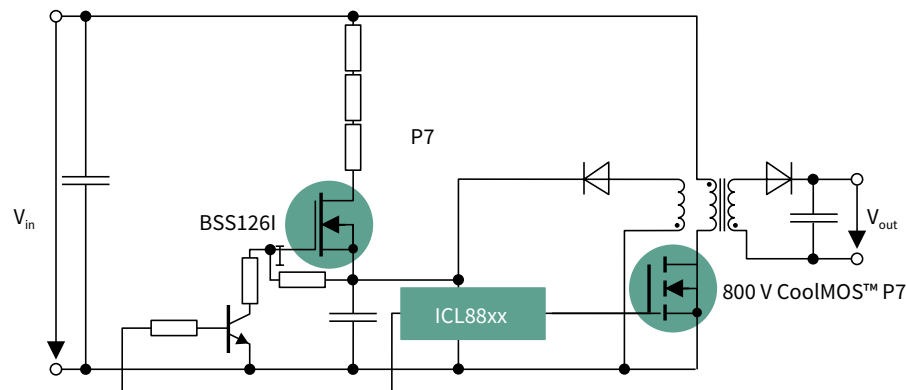

Application note

Name	Description
Engineering report for 130W with ICL5102	130 W dimmable constant current LED driver using PFC and LLC
320 W multichannel high-power LED driver	Engineering Report using ICL5102 + ID8150

Evaluation board

Name	Products	Description
REF-ICL5102-U130W-CC	ICL5102, 600 V CoolMOS™ CE, BSS126I	PFC/LLC evaluation board 130 W LED driver
REF_LLC_BUCK_4CH_320W	ICL5102, ILD8150E, 600 V CoolMOS™ P7, BSS126I	Scalable 320 W multichannel high-power LED driver (using ICL5102 and ILD8150)

IRS2982S – single-stage PFC/flyback controller for constant voltage output

Features

- › Integrated 600 V high-voltage start-up cell
- › Multi-mode operation, DCM operation at light loads (minimum off-time)
- › Overvoltage protection
- › Burst-mode operation at very light loads

Benefits

- › Integrated start-up cell enables very high efficiency for wide-range input designs combined with fast time-to-light
- › Optimal efficiency, power factor and THD can be achieved by most suited mode. In addition, DCM eases compliance with EMI at low load condition by limiting the switching frequency

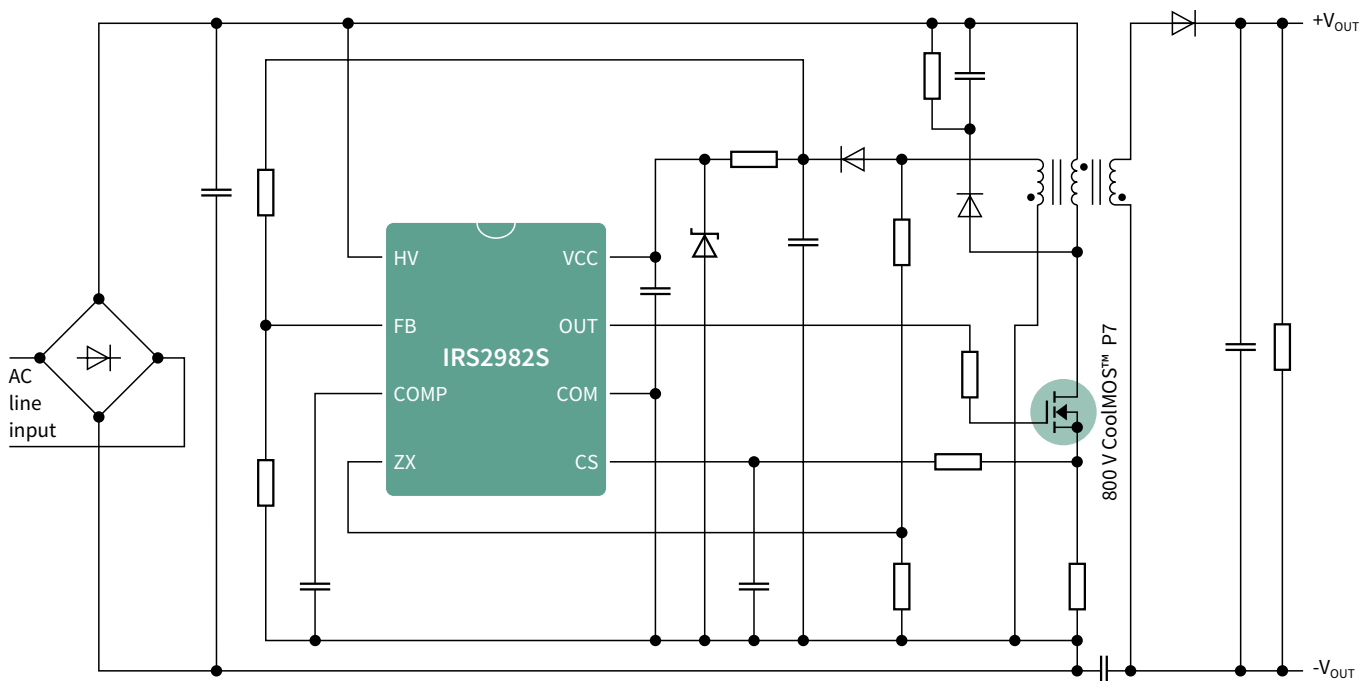

Application note

Name	Description
ANEVAL_201602_PL16_017	55 W flyback converter design using the IRS2982S controller IRXLED04

Evaluation board

Name	Products	Description
IRLXLED04 50W Flyback evaluation board*	IRS2982S , 800 V CoolMOS™ CE , 800 V CoolMOS™ P7	50 W flyback converter design using the IRS2982S controller

* For more information on the product, contact our [product support](#).

www.infineon.com/irs2982

ICE2PCS0xG/ICE3PCS0xG – CCM PFC controller

For power ranges above 300 W, CCM PFC mode offers benefits in terms of efficiency compared to DCM PFC mode.

Features

- › Trimmed internal reference voltage ($2.5\text{ V} \pm 1.2\%$)
- › Low peak current limit threshold
- › Bulk “voltage good” signal for inrush relay control or PWM IC enabling
- › Integrated digital voltage loop compensation
- › Programmable switching (20-100 kHz)
- › External synchronization (50 ~ 100 kHz)
- › Direct sensing, input brown-out detection with hysteresis

Benefits

- › Enhanced dynamic response
- › Ease of use with few external components
- › External current compensation for greater user flexibility

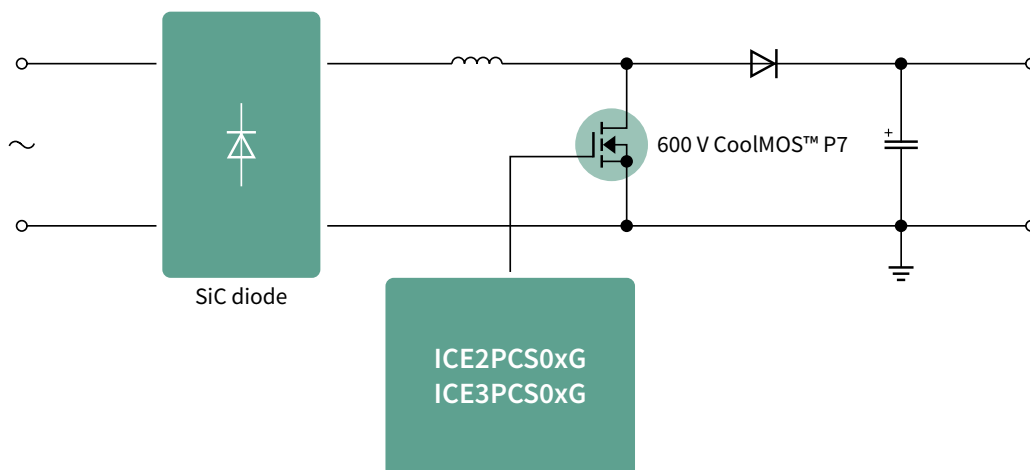

Application note

Name	Description
EVALPFC-300W-ICE3PCS01G	Programmable FF CCM PFC controller ICE2PCS01 for 300 W 393V PFC evaluation board with 85 ~ 265 V AC universal input

Evaluation board

Name	Products	Description
EVALPFC2-ICE2PCS01	CCM PFC controller, SiC diode, CoolMOS™	Programmable FF CCM PFC controller ICE2PCS01 for 300 W 393V PFC evaluation board with 85 ~ 265 V AC universal input

SiC diodes for high-power applications

SiC diodes enable highest efficiency in combination with CCM PFC Controllers in high power LED applications

Features

- › No reverse recovery charge
- › Purely capacitive switching
- › High operating temperature (T_j , max 175 °C)

Benefits

- › System efficiency improvement compared to Si diodes
- › Reduced cooling requirements
- › Enabling higher frequency/increased power density
- › Higher system reliability
- › Reduced EMI



Continuous forward current, I_F [A]	TO-252 (DPAK real 2-leg)	TO-220 (real 2-leg)	TO-247-3	TO-247-2	D ² PAK-2
2	IDM02G120C5	IDH02G120C5			IDK02G120C5
5	IDM05G120C5	IDH05G120C5			IDK05G120C5
8	IDM08G120C5	IDH08G120C5			IDK08G120C5
10	IDM10G120C5	IDH10G120C5	IDW10G120C5B	IDWD10G120C5	IDK10G120C5
15–16		IDH16G120C5	IDW15G120C5B	IDWD15G120C5	IDK16G120C5
20		IDH20G120C5	IDW20G120C5B	IDWD20G120C5	IDK20G120C5
30			IDW30G120C5B	IDWD30G120C5	
40			IDW40G120C5B	IDWD40G120C5	

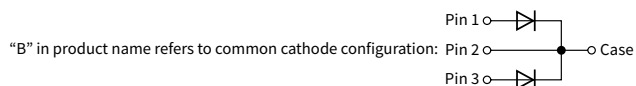

Digital flyback controllers

XDPL8105 - multi-mode PFC/flyback controller

XDPL8105 is a primary-controlled high-performance single-stage PFC/flyback controller with constant current output.

Features

- > Multi-mode operation, quasi-resonant, discontinuous conduction mode (DCM)
- > Active burst mode (ABM)
- > Integrated 600 V start-up cell
- > Configurable parameters
- > Supports fully isolated 0 – 10 V dimming

Benefits

- > Optimal efficiency, power factor and THD can be achieved by most suited mode. In addition, DCM eases compliance with EMI at low load condition by limiting the switching frequency
- > ABM enables low-level analog dimming
- > Integrated start-up cell enables very high efficiency for wide-range input designs combined with fast time-to-light
- > Configurability of parameters like output current, protection modes and dimming curves enables last-minute adjustments, reducing stockkeeping

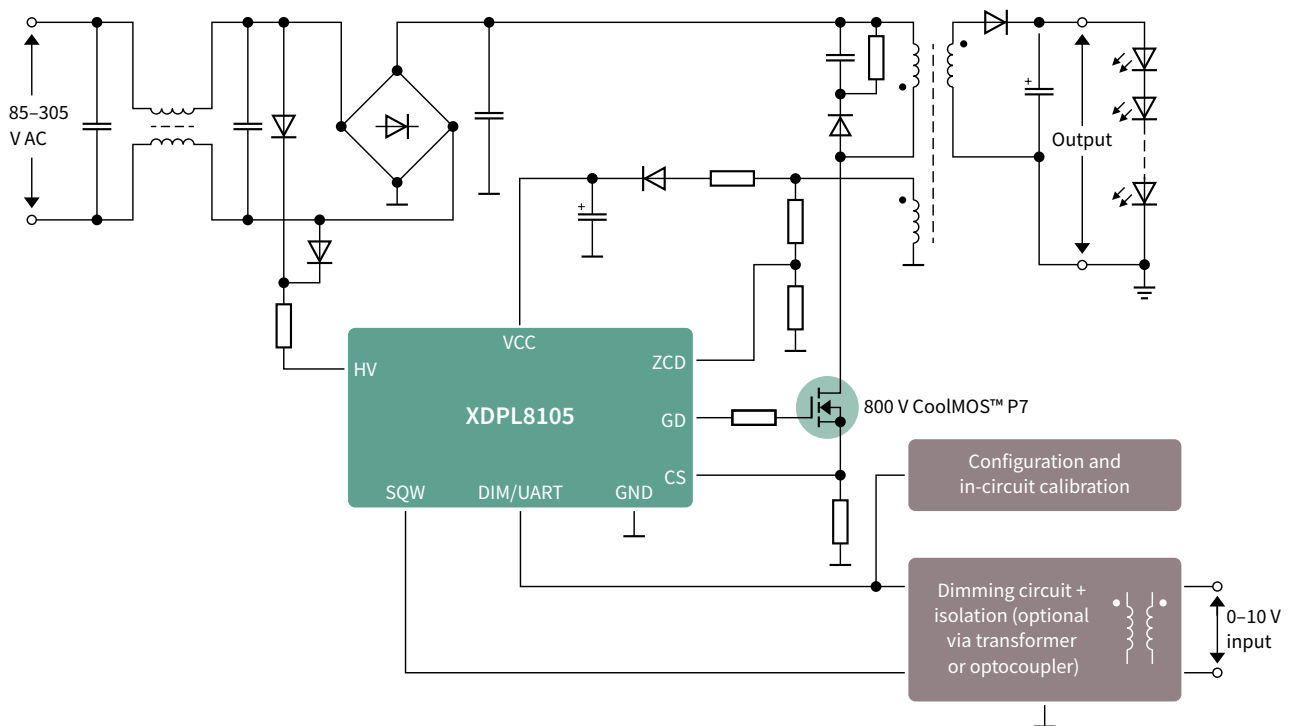

Application note

Name	Description
AN_1904_PL21_1905_103930	40 W demoboard with isolated 0–10 V dimming interface
System Simulation & Design Creation Tool	Transformer, BOM and IC parameters

Evaluation board

Name	Products	Description	Order number
REF-XDPL8105-CDM10V	XDPL8105, 800 V CoolMOS™ P7	Reference board for XDPL8105 with dimming	SP001649474

www.infineon.com/xdpl8105

Digital flyback controllers

XDPL8210 - multi-mode PFC/flyback controller for 1% dimming

XDPL8210 is a primary-controlled single-stage PFC/flyback controller with constant current output that supports 1% dimming.

Features

- > All features included in [XDPL8105](#)
- > 1% dimming
- > Supports 0-10 V dim-to-off powering the dimmer
- > Limited Power (LP) mode
- > PWM dimming input pin
- > Enables BOM savings for the dimming circuit

Benefits

- > All benefits included in [XDPL8105](#)
- > Well suited for indoor lighting application where 1% dimming is required
- > Cost savings for an additional auxiliary power supply for the 0-10 V dimmer
- > Well suited for outdoor lighting in cold areas since LP mode enables start-up of LEDs even when their forward voltage is above the nominal output voltage

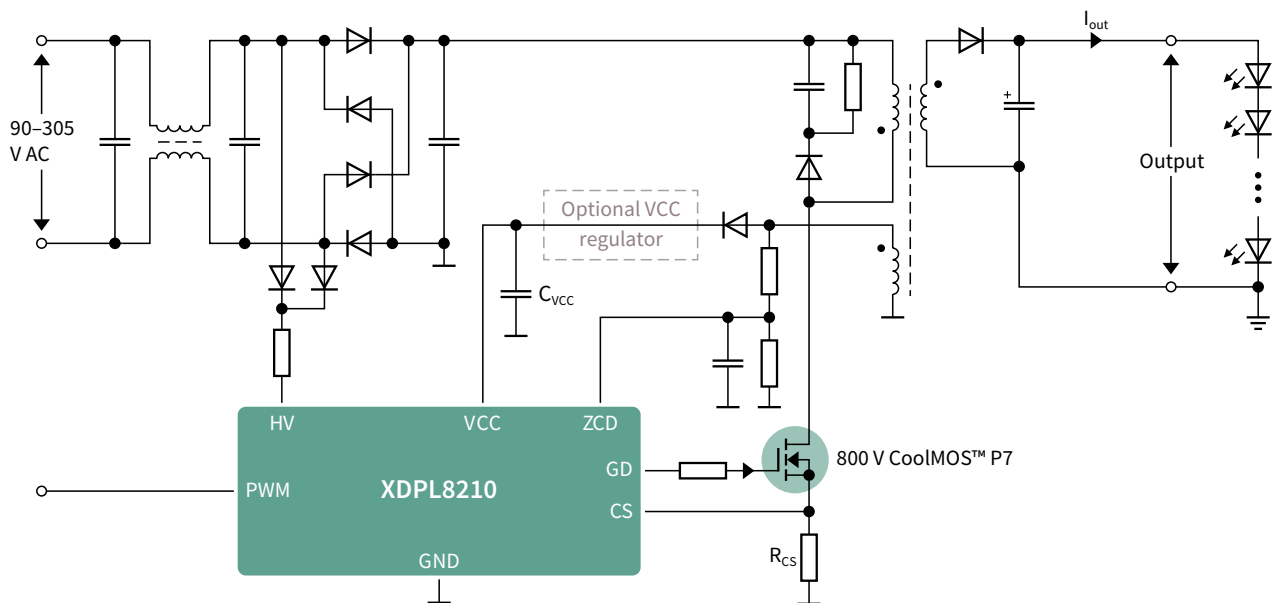

Application note

Name	Description
ER_1902_PL21_1903_042903	XDPL8210 CDM10VD 35 W reference design with IPN80R900P7 – LED driver with isolated 0 to 10 V dimming and dim-to-off operation

Evaluation board

Name	Products	Description	Order number
REF-XDPL8210-U35W	XDPL8210, 800 V CoolMOS™ P7	XDPL8210 35 W constant current reference board with 0-10 V dimming interface	SP001886070

XDPL8219 – PFC/flyback controller with enhanced total harmonic distortion

XDPL8219 is a high-performance secondary-side regulated flyback controller with constant voltage output and high power factor with enabling smart lighting applications.

Features

- › Secondary-Side-Regulated (SSR)
Constant Voltage (CV) output
- › Flyback controller with power factor correction
- › Depending on load condition, either quasi-resonant, discontinuous conduction mode or active burst mode (ABM)
- › Integrated 600 V start-up cell

Benefits

- › Supporting wide load range and fast and stable reaction to dynamic load changes
- › $PF > 0.9$ and $THD < 10\%$ across a wide load range (AC input up to $277 V_{rms}$)
- › Optimal efficiency, power factor and THD can be achieved by best-suited mode. In addition, DCM eases compliance with EMI at low-load condition
- › Very low stand-by power $< 100 \text{ mW}$ can be achieved
- › Integrated start-up cell enables very high efficiency

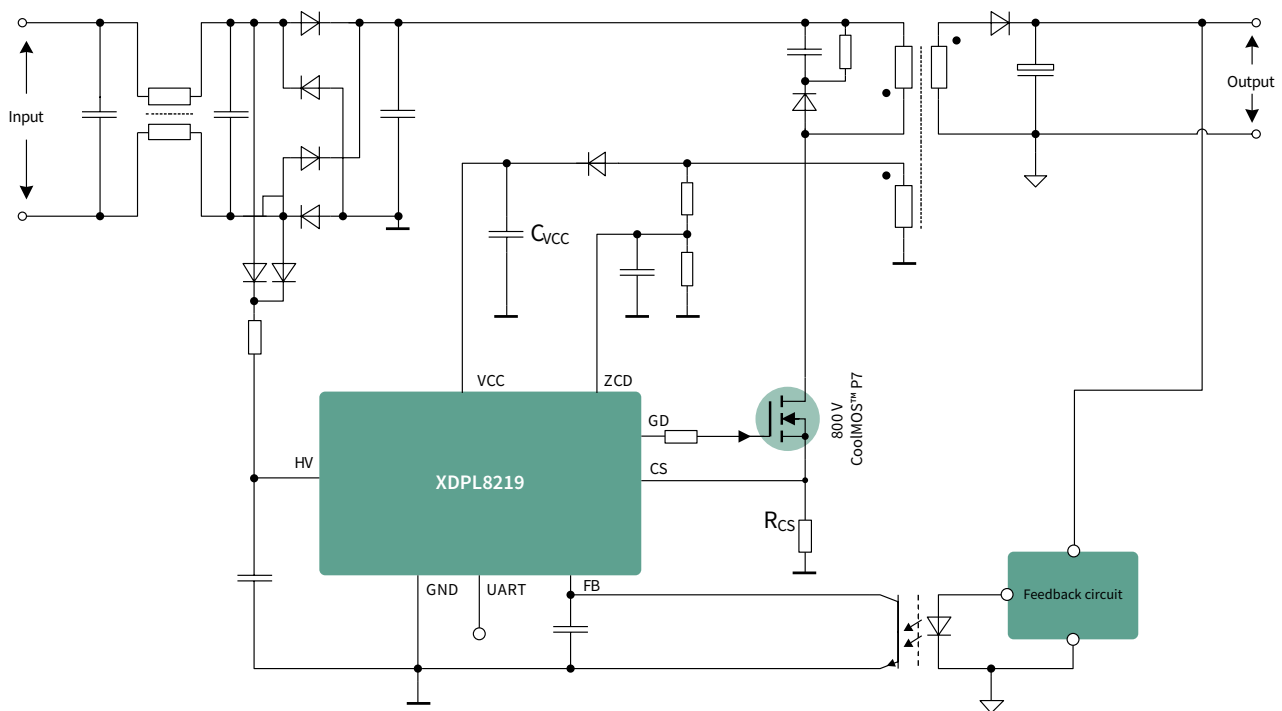

Application note

Name	Description
DG_2005_PL21_2006_124819	XDPL8219 design guide –high power factor flyback converter with constant voltage output

Evaluation board

Name	Products	Description	Order number
REF-XDPL8219U40W	XDPL8219, 800 V CoolMOS™ P7	Efficient 40 W reference circuit design for XDPL8219 with high power factor and low THD. It is built for universal input voltage 120–277 V AC or 127–432 V DC	SP002990946

Digital flyback controllers

XDPL8221 – two-stage intelligent & configurable PFC plus flyback controller

XDPL8221 is a digital quasi-resonant PFC + flyback controller with communication including dimming and reading out of data like fault condition and power monitoring via UART.

Features

- > Two-stage Power Factor Correction (PFC) and flyback controller
- > Primary-Side-Regulated (PSR) multi-mode control: Constant Current (CC), Constant Voltage (CV) and Limited Power (LP)
- > Pulse Width Modulation (PWM) dimming control
- > Total harmonic distortion optimization (QR compensation)

Benefits

- > Enables the design of high performance advanced LED driver for connected lighting with small effort
- > Maximize flexibility for global platform designs
- > Reduce product variants and inventory management complexity
- > 1% dimming and dim-to-off
- > Further improved THD < 15%

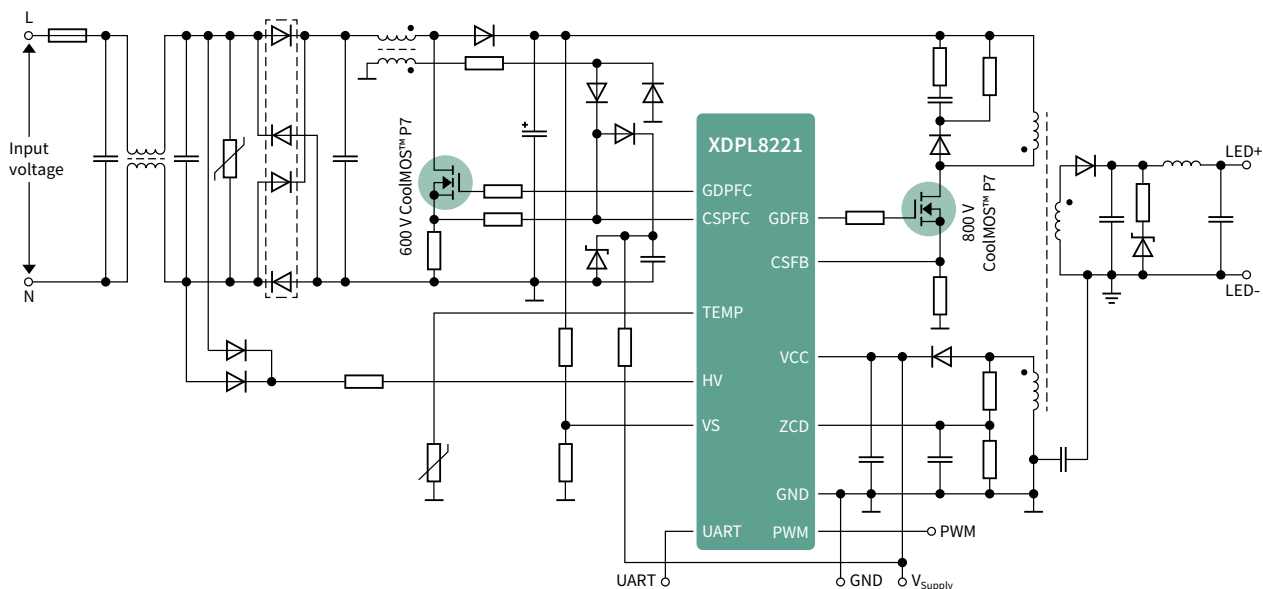

Application note

Name	Description
DG_1711_PL21_1712_143020	XDPL8221 digital PFC + flyback controller IC – a high-performance dual-stage digital PFC + flyback AC-DC converter using the XDPL8221 controller for LED lighting applications
AN_1901_PL21_1902_043849	XDPL8221 limited power mode – the Limited Power (LP) mode of XDPL8221, and the dimming operation in LP mode
AN_1901_PL21_1902_071326	XDPL8221 CSV file parameter description for 50 W reference design – the parameters defined in the CSV file for the XDPL8221 digital controller

Evaluation board

Name	Products	Description	Order number
REF-XDPL8221-U50W	XDPL8221, 700 V and 800 V CoolMOS™ P7	Efficient and flicker-free reference circuit design for XDPL8221 with high power factor and low THD. It is built for universal input voltage (100–277 V AC) and for 50 W output power	SP003127452
REF-XDPL8221-U100W	XDPL8221, 600 V CoolMOS™ C6 and 800 V CoolMOS™ P7	Efficient and flicker-free reference circuit design for XDPL8221 with high power factor and low THD. It is built for universal input voltage (100–277 V AC) and for 100 W output power	SP001710982

www.infineon.com/xdpl8221

PFC plus half-bridge resonant controllers

ICL5102

ICL5102 is a PFC plus half-bridge resonant controller that has excellent PFC and THD performance combined with high-frequency operation in order to minimize the bill of materials.

Features

- › Integrated two-stage combination controller
- › Supports universal AC nominal input voltage (90 to 305 V_{RMS})
- › Excellent system efficiency of up to 94%
- › THD optimization ensures low harmonic distortion (Total Harmonic Distortion (THD) < 5%) down to 30% nominal load
- › Maximum 500 kHz HB switching frequency and soft-start frequency up to 1.3 MHz

Benefits

- › Simplify system design for PFC plus LLC/LCC topologies with less component counts and optimized bill of materials (BOM) and form factor
- › Address global platforms with one IC
- › Strong efficiency, PF and THD performance packaged in a combo-IC
- › Integrated coreless transformer offers robustness against dV/dt, negative voltage
- › Minimize form factors due to high switching frequency capability

ICL5102 – typical application with PFC + LCC topology

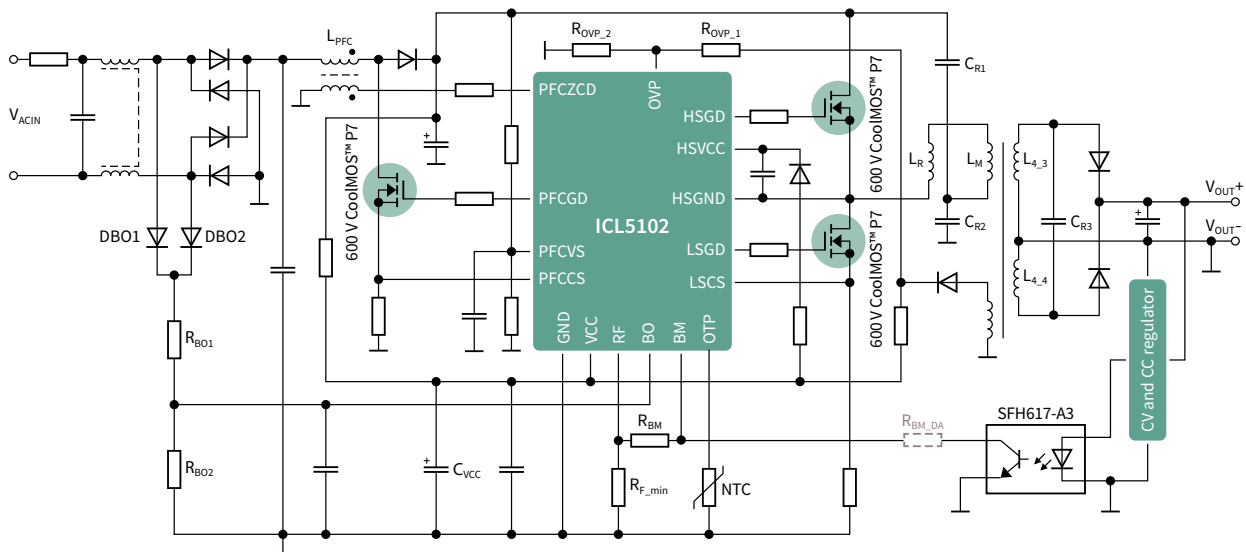

Application note

Name	Description
Engineering report for 52 W with IC5102	52 W low-cost two-stage LED driver based on ICL5102
Engineering report for 130 W with ICL5102	130 W dimmable constant current LED driver using PFC and LLC
320 W multichannel high-power LED driver	Engineering Report using ICL5102 + ID8150

Evaluation board

Name	Products	Description	Order number
REF-ICL5102-U52W-CC	ICL5102, 600 V CoolMOS™ P7	Low-cost PFC/LCC evaluation board 52 W LED driver	SP005419724
REF-ICL5102-U130W-CC	ICL5102, 600 V CoolMOS™ CE, BSS126I	PFC/LLC evaluation board 130 W LED driver	SP001667160
REF_LLC_BUCK_4CH_320W	ICL5102, ILD8150E, 600 V CoolMOS™ P7, BSS126I	Scalable 320 W multichannel high-power LED driver (using ICL5102 and ILD8150)	SP005424809

ICL5102HV

ICL5102HV is a PFC plus resonant combo controller that has excellent PFC and THD performance combined with high-frequency operation in order to minimize the bill of materials.

Features

- > All features mentioned in ICL5102
- > High voltage (HV) version supports (90 to 480 V_{RMS})

Benefits

- > All benefits mentioned in ICL5102
- > ICL5102HV can be used in street lighting, horticultural lighting and industrial lighting where 480 V AC is used as input voltage

ICL5102HV - typical application with PFC + LLC topology

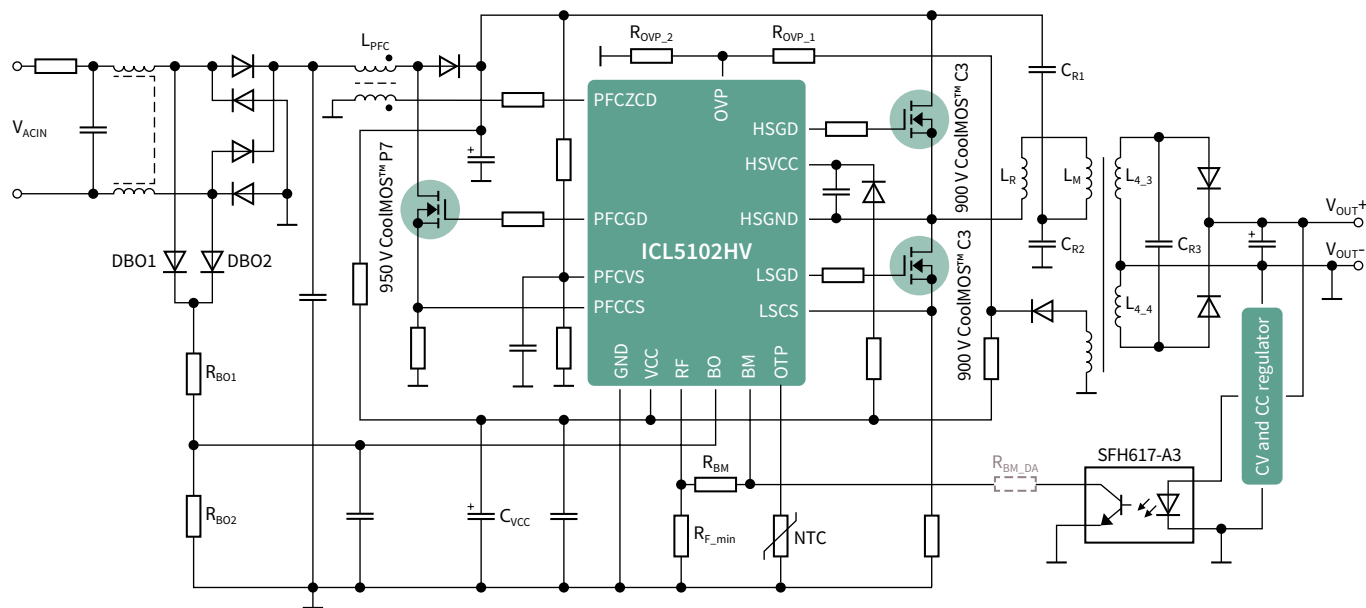

Application note

Name	Description
Reference design for 150W with ICL5102HV	150 W LCC LED driver demonstration board with ICL5102HV

Evaluation board

Name	Products	Description	Order number
REF-ICL5102HV-U150W	ICL5102HV, 900 V CoolMOS™ C3* and 950 V CoolMOS™ P7, IPD530N15N3 G	ICL5102HV 150 W LED driver board with V _{in} up to 480 V	SP005346355

DC-DC buck converters and smart linear controller

ILD8150 – 80 V DC-DC buck LED driver IC

ILD8150 is a DC-DC LED driver IC with 80 V breakdown voltage with an integrated MOSFET.

Features

- > Input voltage up to 80 V
- > Integrated MOSFET for up to 1.5 A output current
- > Analog dimming down to 12.5% and PWM dimming from 12.5% to 0.5%
- > Current precision $\pm 3\%$
- > Soft-start, UVLO, current limitation, low-power shutdown

Benefits

- > High safety margin for voltage transients and spikes
- > Optimal BOM due to integrated MOSFET
- > Deep dimming performance without flicker and noise via innovative one-pin hybrid method
- > High current precision leads to high light quality
- > Fast, stable and efficient regulation

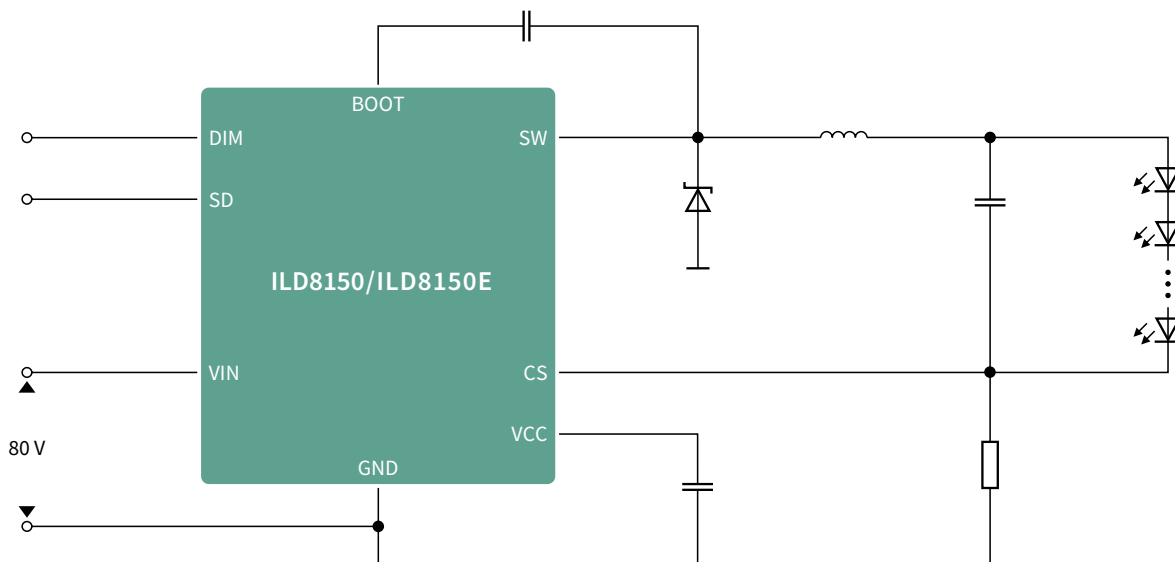

Application note

Name	Description
REF_ILD8150_DC_1.5A high frequency operation	High-frequency operation with ILD8150
Reference board REF_ILD8150_DC_1.5A LED driver IC ILD8150 80V	Operation, design guide and performance
320 W multichannel high-power LED driver	Engineering Report using ICL5102 + ID8150

Evaluation board

Name	Products	Description	Order number
REF_ILD8150_DC_1.5A	ILD8150E	Reference design board 1.5 A with coil inductor	SP002798058
REF_ILD8150_DC_1.5A_SMD	ILD8150E	Reference design board 1 A with SMD inductor	SP005351260
REF_LLC_BUCK_4CH_320W	ICL5102, ILD8150E, 600 V CoolMOS™ P7, BSS126I	Scalable 320 W multichannel high-power LED driver (using ICL5102 and ILD8150)	SP005424809
REF_TW_ILD8150E_60V_1A*	ILD8150E, IFX1117ME V33	Reference board for professional tunable white and multichannel applications	SP005433043

*Coming soon

www.infineon.com/ild8150
www.infineon.com/ild8150e

DC-DC buck converters and smart linear controller

BCR601 – 60 V linear LED controller with active headroom control

BCR601 is a linear controller that enables high efficiency at low cost as a second-stage LED controller to replace DC-DC buck converters especially in low- to mid-power LED drivers.

Features

- > Input voltage up to 60 V
- > Voltage feedback to primary side
- > Can be operated with either BJT or N-channel MOSFET
- > Analog dimming down to 3%
- > Current precision $\pm 3\%$
- > OTP, OVP, hot-plug protection

Benefits

- > Well suited for LED drivers with SELV
- > Reducing voltage overhead and power loss in transistor for better system efficiency
- > Cost and performance can be optimized by selection of BJT or N-channel MOSFET
- > High light quality without flicker
- > Safe operation

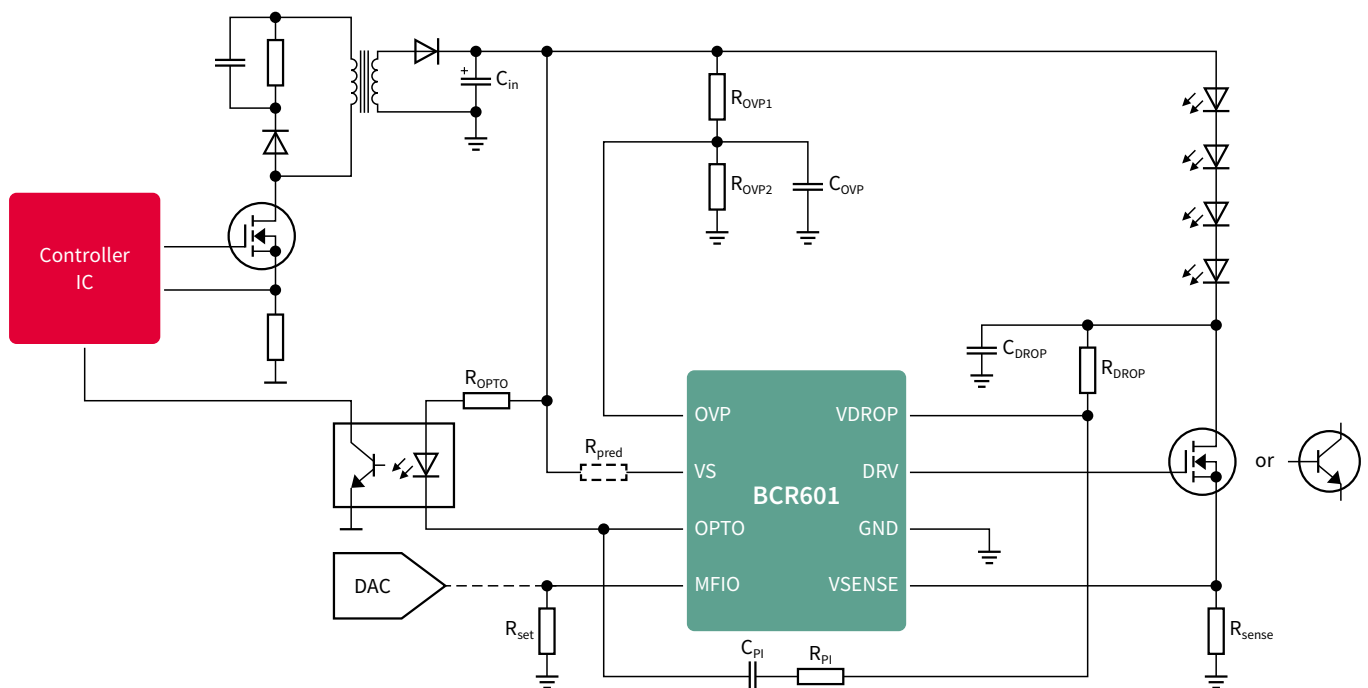

Application note

Name	Description
Design guide lighting ICs linear LED controller 60V BCR601	Design guide for a linear controller IC with feedback loop to primary side
Engineering report demoboard DEMO_BCR601_60V_IVCTRL	Engineering report for 60 V, 500 mA linear LED controller demonstration board

Evaluation board

Name	Products	Description	Order number
DEMO_BCR601_60V_IVCTRL	BCR601, BSP716N	This board is intended for the design evaluation of very cost-efficient, highly reliable, power-efficient LED drivers with linear LED driver IC BCR601	SP002798056

IRS2982 – universal controller for high voltage buck

IRS2982 is a multi-mode LED driver IC that can be used for the flyback stage mainly for constant voltage output as well as for the buck stage of non-isolated PFC boost followed by a high-voltage buck.

Features

- › Integrated 600 V high-voltage start-up cell
- › Multi-mode operation, DCM operation at light loads (minimum off-time)
- › Overvoltage protection
- › Burst-mode operation at very light loads

Benefits

- › Integrated start-up cell enables very high efficiency for wide-range input designs combined with fast time-to-light
- › Optimal efficiency, power factor and THD can be achieved by most suited mode. In addition, DCM eases compliance with EMI at low load condition by limiting the switching frequency

Second-stage buck convertor using IRS2982S

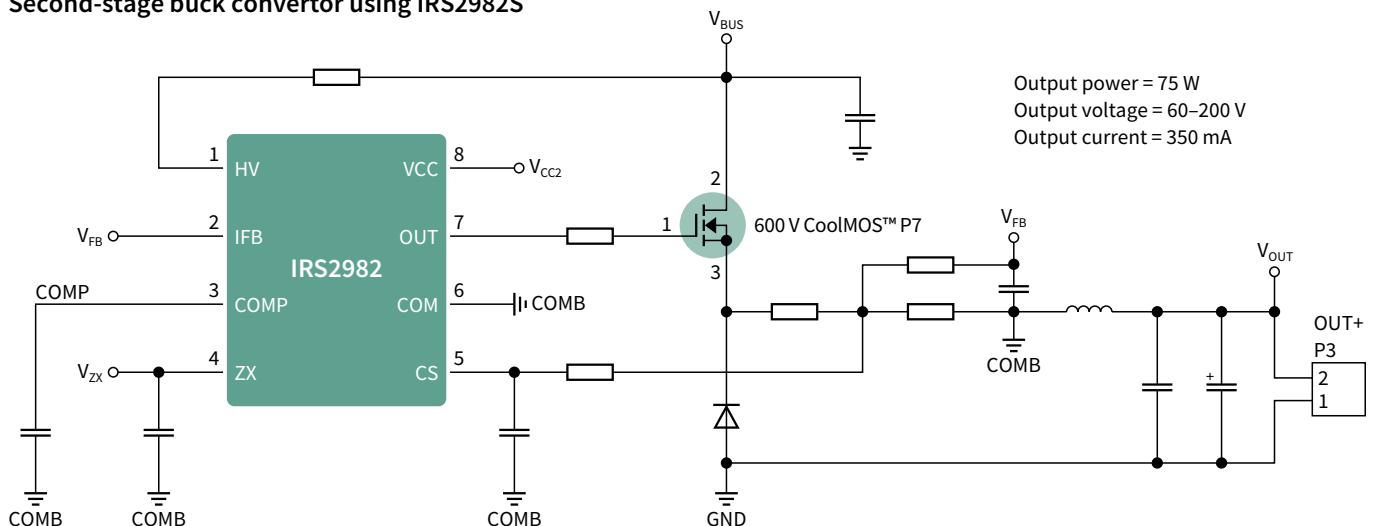

Supply for IRS2982 IC and optocoupler

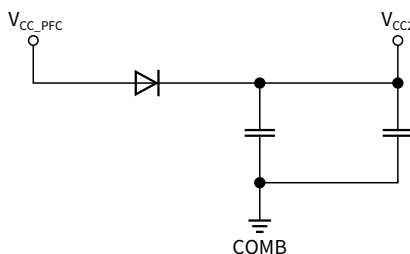

ZX detection

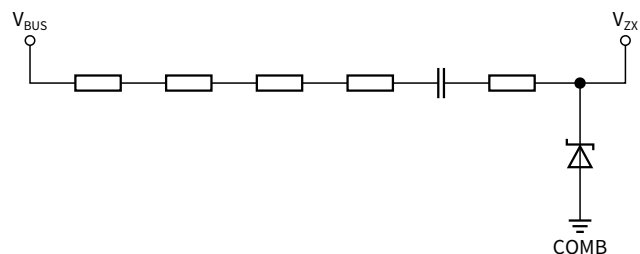

Application note

Name	Description
AN_1808_PL16_1809_234920	Non-isolated two-stage boost PFC plus current-regulated buck LED driver IRXLED10

Evaluation board

Name	Products
IRXLED10*	IRS2505L, IRS2982S, 600 V CoolMOS™ P7 (IPP60R360P7)

CoolMOS™ – high-voltage MOSFETs

Trusted leader in high-voltage MOSFETs

CoolMOS™ is an extremely well-established technology in LED driver applications. The main reasons why LED driver customers choose CoolMOS™ include:

- > Proven quality and reliability
- > High efficiency
- > High-volume supply capability
- > Continuous portfolio expansion

For new designs, many LED driver makers are opting for the newest generation of CoolMOS™, namely the P7 family. Highlights of this latest generation include the best price/performance ratio and highly granular $R_{DS(on)}$ classes combined with diverse packages.

The SOT223 package, footprint-compatible with standard DPAK packages, has been a great success story in the lighting industry.

Another product family that has seen very high traction among lighting customers is the 950 V P7 family. Optimized for flyback topologies, where breakdown voltages above 800 V are required, 950 V P7 devices are emerging as the solution of choice among our customers.

Our 600 V P7 portfolio is designed for high efficiency across all higher-power applications with an $R_{DS(on)}$ of up to 600 mΩ. For lower-power applications that require 600 V with an $R_{DS(on)}$ of > 600 mΩ, we recommend either 600 V CE or 700 V P7 devices. 700 V P7 is well suited to the PFC and fly-back stage. 600 V CE is a universal solution that can be used in all low-power topologies with an $R_{DS(on)}$ of > 600 Ω.

Aware that security of supply is a key success factor for our customers, we usually manufacture our products at multiple factories. This aspect might be considered for designs where superior performance of CoolMOS™ can help to differentiate your products from competitors.

CoolMOS™ superjunction MOSFETs for lighting applications

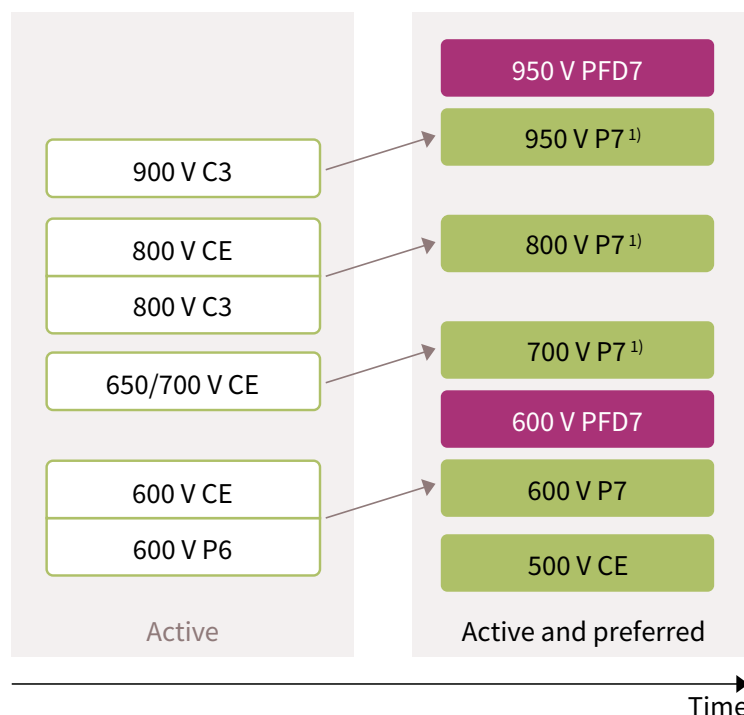

1) Optimized for flyback topologies

■ Price-performance ■ Fast recovery diode

CoolMOS™ – high-voltage MOSFETs

950 V CoolMOS™ PFD7

The 950 V CoolMOS™ PFD7 is a revolutionary superjunction technology for high-voltage power MOSFETs, with an integrated fast body diode to address lighting and industrial SMPS applications. The new series is tailor-made for usage across several topologies, such as PFC, LLC, and flyback.

Features

- › Integrated ultra-fast body diode with BiC Q_{rr}
- › Best-in-class FOM $R_{DS(on)} \times E_{oss}$; reduced Q_g , C_{iss} and C_{oss}
- › $R_{DS(on)}$ in various packages like 450 mΩ in DPAK and 60 mΩ in TO-247
- › $V_{(GS)th}$ of 3 V and smallest $V_{(GS)th}$ variation of ± 0.5 V
- › ESD protection up to class 2 (HBM)
- › Offering the highest quality and reliability
- › Price competitiveness over previous CoolMOS™ families

Benefits

- › Hard commutation ruggedness that enables the usage of PFD7 in different circuit topologies
- › Improved efficiency and thermal behavior over internal and external comparable products
- › Enabling higher power density designs and BOM savings
- › Easy to drive and design-in
- › Improved production yield by reducing ESD-related failures and reduced field returns
- › Cost-competitive designs with superjunction

Efficiency measurements for 310 mΩ devices at 90 V_{AC} ($R_{g,ext} = 10 \Omega$)

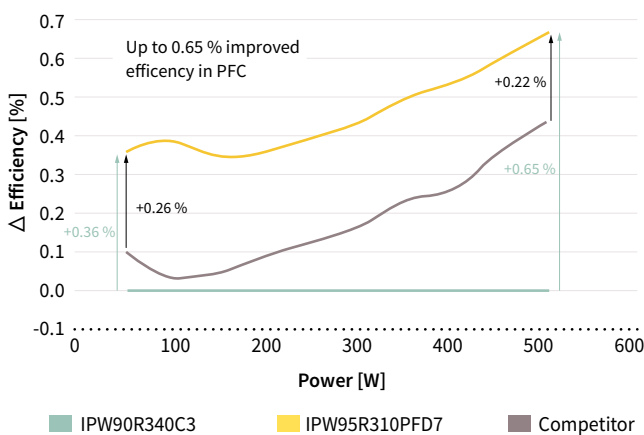

950 V CoolMOS™ PFD7 outperforms previous CoolMOS™ families as well as the main competition concerning PFC efficiency:

- › Improvement of 0.26 percent in light-load and 0.22 percent in full-load efficiency compared to the main competition
- › Improvement of 0.36 percent in light-load and 0.65 percent in full-load efficiency compared to 900 V CoolMOS™ C3

Efficiency measurements for 310 mΩ in 880 W ZVS FB set up

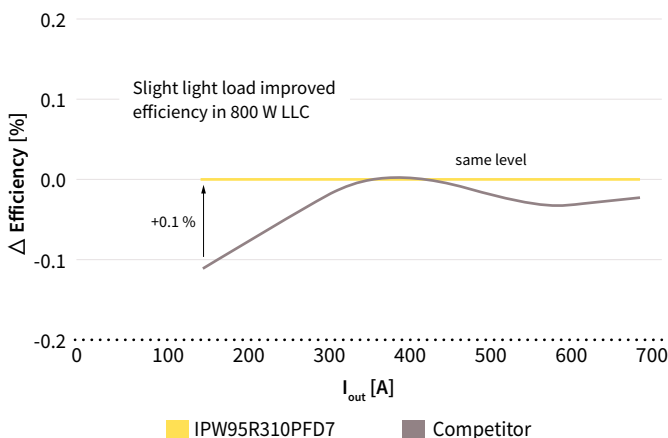

950 V CoolMOS™ PFD7 closes the gap and matches the performance of the main competition regarding LLC efficiency:

- › Improvement of 0.1 percent in light-load efficiency compared to the main competition

CoolMOS™ – high-voltage MOSFETs

950 V CoolMOS™ P7

Designed to meet growing consumer needs in the high-voltage MOSFET arena, the latest 950 V CoolMOS™ P7 technology focuses on lighting.

Temperature @ 90 V AC

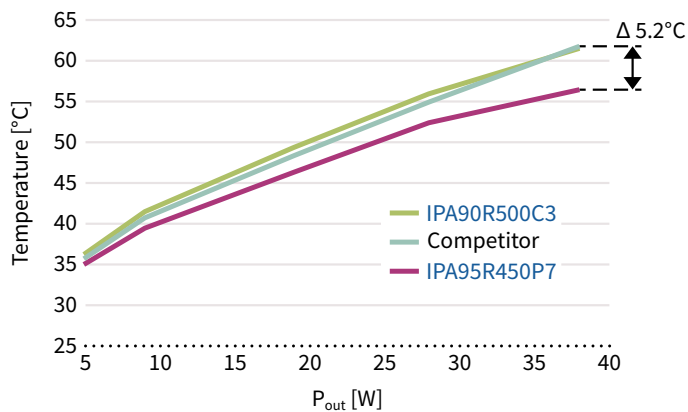

- > The new **950 V CoolMOS™ P7 series** delivers best-in-class performance in terms of efficiency, thermal behavior and ease of use. Like all other P7 family members, the 950 V CoolMOS™ P7 series comes with an integrated Zener diode for ESD protection. This integrated diode considerably improves ESD robustness, thus reducing ESD-related yield loss and offering exceptional ease of use.
- > Plug-and-play at 90 V AC in a 40 W reference design, featuring the snubberless concept, demonstrates excellent efficiency gains of up to 0.2 percent, plus lower MOSFET temperatures with drops of up to 5.2°C compared with similar competitor technology.
- > In the DPAK package, the 950 V CoolMOS™ P7 also offers best-in class $R_{DS(on)}$. This SMD device has an $R_{DS(on)}$ of 450 mΩ – more than 60 percent lower than that of the closest competitor.

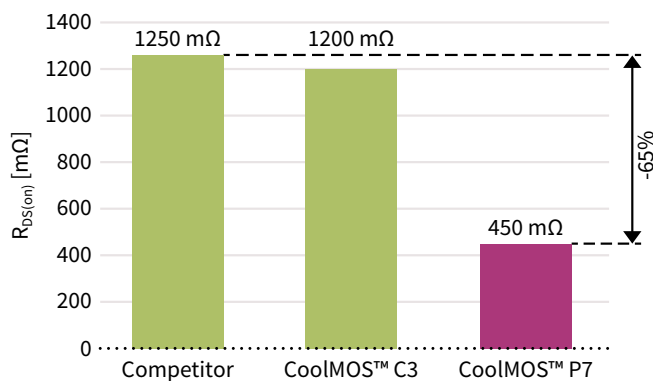

Best-in-class DPAK $R_{DS(on)}$

Customer benefits

- > Option to change from leaded to SMD packages
- > High power density
- > Lower BOM
- > Lower production cost

CoolMOS™ – high-voltage MOSFETs

800 V CoolMOS™ P7

With the 800 V CoolMOS™ P7 series, we have set a benchmark in 800 V superjunction technologies, combining best-in-class performance with remarkable ease of use. This new product family is a perfect fit for flyback-based LED driver applications. It is also suitable for PFC stages, offering a price/performance ratio to meet all market needs.

This technology optimizes key parameters to deliver best-in-class efficiency and thermal performance. As demonstrated through comparisons with a standard, commercially available 80 W LED driver, it reduces switching losses (E_{oss}) and output capacitance (C_{oss}) by more than 45 percent while significantly improving the input capacitance (C_{iss}) and gate charge (Q_G). All of which leads to a 0.5 percent increase in efficiency at light load, which helps to reduce standby power in the end application. At full load, the observed improvement is up to 0.3 percent for efficiency coupled with a 6°C drop in device temperature.

Plug and play in an 80 W LED driver from market

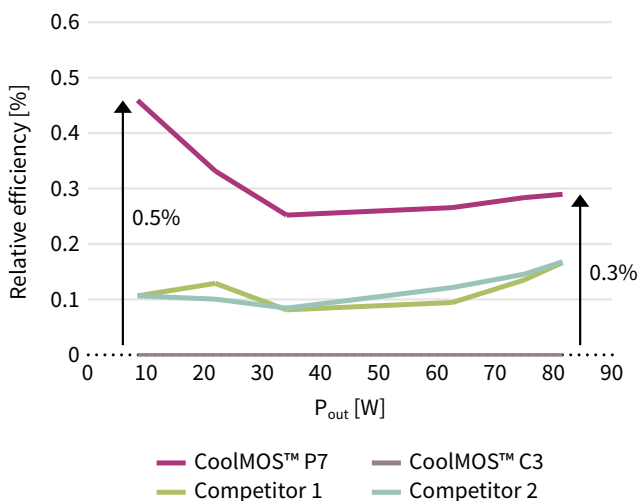

As mentioned in the introduction, the choice of MOSFET will influence system efficiency. Due to benchmark switching losses, the 800 V CoolMOS™ P7 series can achieve very high levels of system efficiency. This efficiency gain relative to market-standard products widens under dimming conditions.

Compared with the competition, the 800 V CoolMOS™ P7 technology allows designers to integrate much lower $R_{DS(on)}$ values into small and cost-effective packages such as DPAK. The same applies to even smaller and low-cost packages like SOT223. The 800 V P7 in a SOT223 package is footprint-compatible with the DPAK.

Overview of lowest DPAK $R_{DS(on)}$ for 800 V superjunction MOSFET

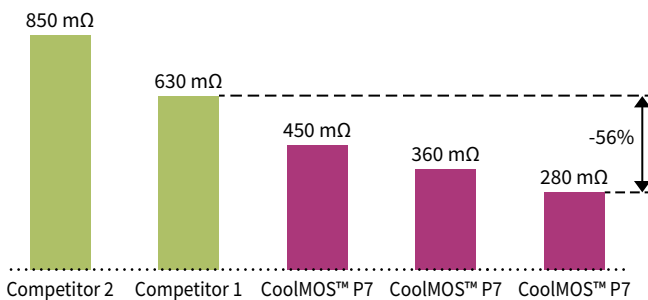

CoolMOS™ P7 sets a new benchmark in best-in-class DPAK $R_{DS(on)}$

Customer benefits

- > High power density
- > Lower BOM
- > Lower production cost

The complete P7 platform has been developed with an integrated Zener diode to protect against electrostatic discharge (ESD). This increases the overall device ruggedness up to Human Body Model (HBM) class 2.

CoolMOS™ – high-voltage MOSFETs

700 V CoolMOS™ P7

Features

- › High-performance technology
 - Low switching losses (E_{oss})
 - Highly efficient
 - Excellent thermal behavior
- › Support for high-speed switching
- › Integrated protection with Zener diode
- › Optimized $V_{GS(th)}$ (3 V) with very narrow tolerance (± 0.5 V)
- › Highly granular portfolio

There are two main use cases for 700 V LED drivers. The main one is as a PFC stage for outdoor lighting, where 600 V might be borderline. For outdoor lighting, some LED driver designs have been deploying 650 V MOSFETs due to higher surge requirements relative to indoor lighting schemes. 700 V CoolMOS™ P7 is a highly cost-effective alternative to the 650 V MOSFETs with the added bonus of extra buffer.

Benefits

- › Cost-competitive technology
- › Further efficiency gain at higher switching speeds
- › Smaller magnetic size with lower BOM
- › High ESD ruggedness up to HBM class 2
- › Easy to drive and design-in
- › Enabler for smaller form factors and high power density designs
- › Best-fit product for demanding applications

The second use case is as a single-stage flyback design for narrow-range systems with 120 V and 230 V input voltages. 800 V MOSFETs will probably remain the devices of choice for single-stage flyback designs. Rising cost pressures for some narrow-range designs may position 700 V as a cost-effective alternative to 800 V MOSFETs.

Relative efficiency @ 230 V_{AC};

$T_{amb} = 25^{\circ}\text{C}$

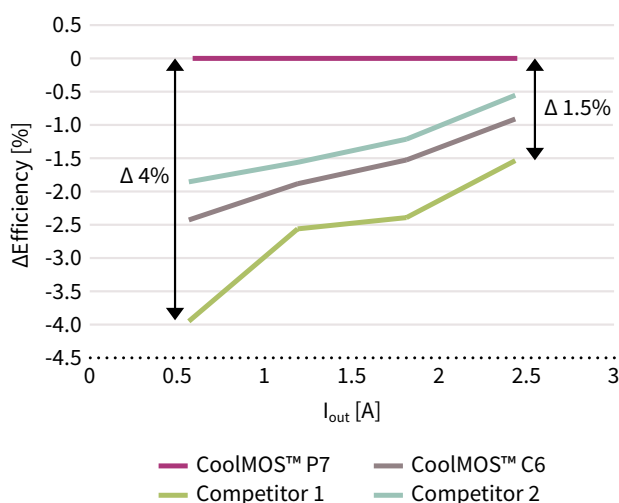

Relative temperature @ 230 V_{AC};

$T_{amb} = 25^{\circ}\text{C}$, 30 min burn-in

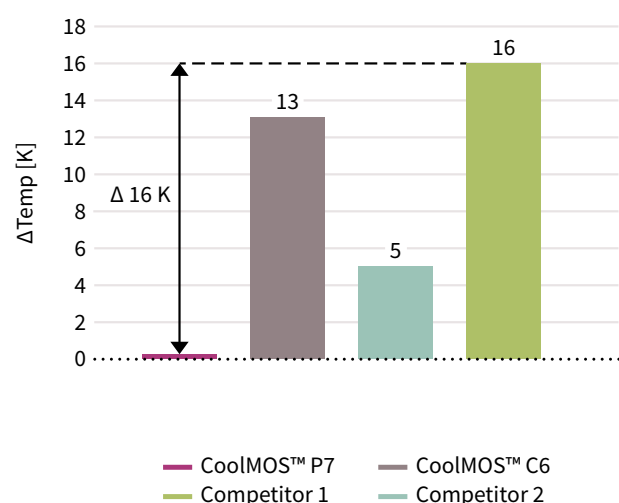

CoolMOS™ – high-voltage MOSFETs

600 V CoolMOS™ P7

The 600 V CoolMOS™ P7 can be used for very different stages within LED drivers.

- > PFC stage
- > Half-bridge stage
- > Buck stage

It offers the highest efficiency and improved power density due to significant reduction in gate charge (Q_G) and switching losses (E_{OSS}) levels, coupled with optimized $R_{DS(on)}$.

The carefully selected integrated gate resistors enable very low ringing tendency. The body diode is exceedingly robust

Features

- > Suitable for hard and soft switching (PFC and LLC) due to outstanding commutation ruggedness
- > Optimized balance between efficiency and ease of use
- > Significant reduction of switching and conduction losses leading to low MOSFET temperature
- > Excellent ESD robustness > 2 kV (HBM) for all products
- > Better $R_{DS(on)}$ /package combinations than the competition
- > Large portfolio with granular $R_{DS(on)}$ values, qualified for a variety of industrial and consumer applications

against hard commutation, making it suited to hard- and soft-switching topologies such as LLC.

In addition, excellent ESD capability helps to improve the manufacturing quality.

The 600 V CoolMOS™ P7 family offers a wide range of $R_{DS(on)}$ /package combinations, including THD and SMD devices, with $R_{DS(on)}$ scaling from 24 to 600 mΩ. This device offers the most competitive price/ performance ratio of all 600 V CoolMOS™ offerings.

Above 600 mΩ, a 600 V CoolMOS™ CE is recommended.

Benefits

- > Ease of use and fast design-in thanks to low ringing tendency and suitability for PFC and PWM stages
- > Improved efficiency and simplified thermal management due to low switching and conduction losses
- > Higher manufacturing quality due to > 2 kV ESD protection
- > Increased power density by decreasing device footprint
- > Suitable for a wide variety of applications and power ranges

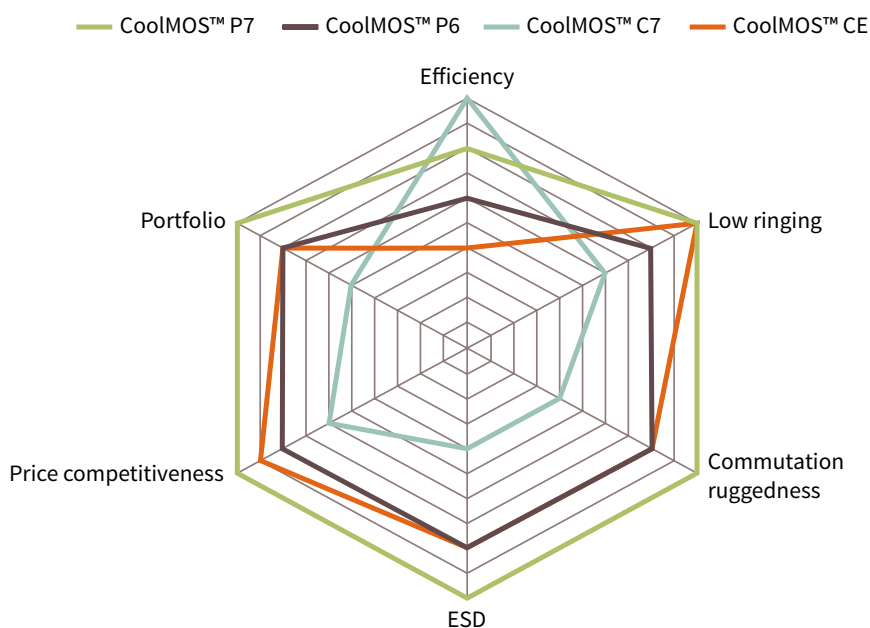

OptiMOS™ 5 – medium-voltage MOSFETs

OptiMOS™ 5 150 V for synchronous rectification

The wide OptiMOS™ portfolio ranging from 100 V to 250 V enables the highest efficiency levels in synchronous rectification. OptiMOS™ consistently sets the benchmark for key design success factors including $R_{DS(on)}$, leading to reduced power losses and improved overall efficiency.

Features

- > Ultralow reverse recovery charge
- > Suitable for low-voltage drives
- > $R_{DS(on)}$ up to 25 percent lower than next-best alternative in SuperSO8
- > Q_{rr} without compromising FOM_{gd} and FOM_{OSS}

Benefits

- > Increased commutation ruggedness
- > Significant drop in design effort
- > Optimized system efficiency

OptiMOS™ 150 V normal level

$R_{DS(on)}$ max @ $V_{GS} = 10$ V [mΩ]	TO252 (DPAK)	SuperSO8
16–30	IPD200N15N3 G $R_{DS(on)} = 20.0$ mΩ	BSC190N15NS3 G $R_{DS(on)} = 19.0$ mΩ
30–60	IPD530N15N3 G $R_{DS(on)} = 53.0$ mΩ	BSC360N15NS3 G $R_{DS(on)} = 36.0$ mΩ
		BSC520N15NS3 G $R_{DS(on)} = 52.0$ mΩ

$R_{DS(on)}$ max @ $V_{GS} = 10$ V [mΩ]	TO-263 D ² PAK	TO-263 D ² PAK 7pin	TO-262 I ² PAK	TO-220	SuperSO8 PQFN 5 x 6	PQFN 3.3 x 3.3
4.0–5.1	IPB048N15N5 $R_{DS(on)} = 4.8$ mΩ	IPB044N15N5 $R_{DS(on)} = 4.4$ mΩ	IPI051N15N5 $R_{DS(on)} = 5.1$ mΩ	IPP051N15N5 $R_{DS(on)} = 5.1$ mΩ		
5.2–11.0	IPB073N15N5 $R_{DS(on)} = 7.3$ mΩ	IPB060N15N5 $R_{DS(on)} = 6.0$ mΩ	IPI076N15N5 $R_{DS(on)} = 7.6$ mΩ	IPP076N15N5 $R_{DS(on)} = 7.6$ mΩ	BSC093N15NS5 $R_{DS(on)} = 9.3$ mΩ	
					BSC110N15NS5 $R_{DS(on)} = 11.0$ mΩ	
> 11.0					BSC160N15NS5 $R_{DS(on)} = 16.0$ mΩ	BSZ300N15NS5 $R_{DS(on)} = 30.0$ mΩ

NFC IC for configuration

NLM0010/NLM0011

Infineon's **NLM0011** is a dual-mode NFC wireless configuration IC with CLO and Pulse Width Modulation (PWM) output, primarily designed for LED applications to enable NFC programming. In addition, advanced features such as the Constant Lumen Output (CLO) as well as the on/off counting are integrated, with no need for an additional microcontroller. The **NLM0010** is a light version of the **NLM0011** without CLO function.

Features

- › Configurable Pulse Width Modulation (PWM) output
- › NFC contactless interface compliant with ISO/IEC 18000-3 mode 1 (ISO/IEC 15963)
- › Constant Lumen Output (CLO) with 8 configurable points for **NLM0011**
- › Integrated operation-time counter (OTC) and on/off counter
- › Non-volatile memory (NVM) including UID

Benefits

- › Fast and cost-effective implementation of NFC programming and CLO without the need for an additional microcontroller
- › Compatible with most analog LED driver designs using “plug-in resistor” method
- › Stable PWM output with fixed 2.8 V amplitude and $\pm 0.1\%$ duty cycle accuracy
- › Internal voltage regulator (LDO) to avoid influence of unstable external supply voltage

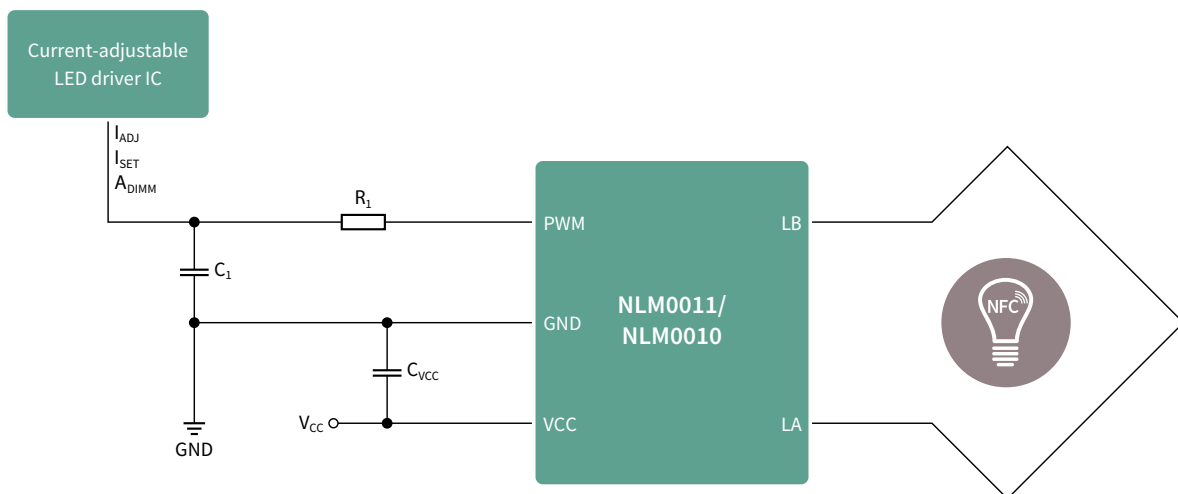

Application note

Name	Description
NLM0011	Dual-mode NFC configuration IC with PWM output and CLO function
NLM0010	Dual-mode NFC configuration IC with PWM output, without CLO function

Evaluation board

Name	Products	Description	Order number
EVAL_NLM0011_DC	NLM0011, IFX20002MBV33, BCM846SH6327XTSA1	NLM0011 evaluation kit - LED power supply with current configuration using NFC-PWM IC	SP005298736

0–10 V dimming interface IC

CDM10V – integrated analog-to-PWM converter for 0–10 V dimming

Features

- › Simplest 0–10 V dimming IC with default settings
 - 5% minimum duty cycle
 - 1 kHz PWM frequency
 - 200 μA dimmer/resistor bias current
 - Dim-to-off disabled
- › The simple one-time programmable option allows setting selection in a wide range
 - Minimum duty cycle: 1%, 2%, 5%, 10%
 - PWM output frequency: 200 Hz, 500 Hz, 1 kHz, 2 kHz
 - Dimmer/resistor bias current: 50 μA , 100 μA , 200 μA , 500 μA
 - Dim-to-off: disabled/enabled
- › Wide input V_{CC} range from 11 to 25 V
- › Transparent PWM mode
(PWM bypass mode in dim-to-off-enabled mode)

Benefits

- › Replace many external components with a single chip, reducing BOM and PCB space
- › Minimize variation from device to device thanks to embedded digital signal processing
- › Easily customizable to design requirements
- › Suitable for various V_{CC} scenarios
- › Wide input V_{CC} range from 11 to 25 V
- › Versatile in complex dimming design

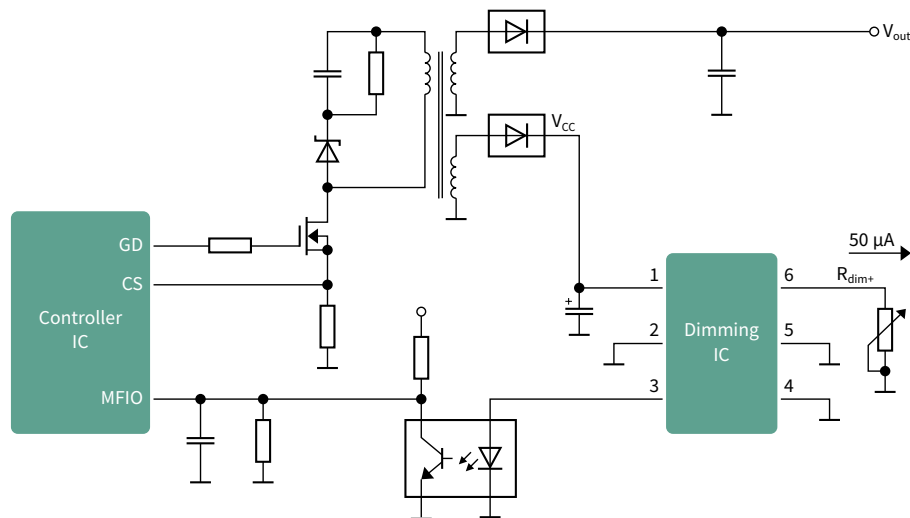

Application note

Name	Description
CoolDim10V Demoboard	40 W reference design with CDM10V isolated 0–10 V dimming interface
COOLDIM_PRG_BOARD	User manual for CDM10V programming board

Evaluation board

Name	Products	Description	Order number
COOLDIM_PRG_BOARD	CDM10V	10 V programming board for CDM10V	SP001493166
REF-XDPL8105-CDM10V	CDM10V , XDPL8105	Reference board for XDPL8105 with dimming	SP001649474
REF-XDPL8210-U35W	CDM10V , XDPL8210 , 800 V CoolMOS™ P7 , BSS169 , BSS123N	35W reference board with isolated 0 to 10 V dimming and dim-to-off operation	SP001886070

www.infineon.com/cdm10v



LED strips and signage

LED strips are being used everywhere from gas stations to cruise ships in a growing number of applications ranging from channel letters to long LED chains. In commercial applications - where product lifetime as well as a homogeneous light output are key priorities - constant

current sources have been well established for the LED strings. These current sources provide from 10 mA to 200 mA LED current compared to the mainstream range of 20 mA to 100 mA.

Linear LED driver ICs

The BCR linear LED drivers are perfectly suited for driving LED currents from 10 mA to 250 mA, making them the ideal choice for low- to mid-power LEDs in general lighting applications.

This represents the lowest-cost solution that requires an ultralow external part count and PCB space. The light output can be adjusted via an external resistor. PWM dimming is supported either by a microcontroller interface or by means of an external digital transistor.

Thanks to its negative thermal coefficient, the LED load will be protected from overheating.

The new-generation [BCR430U](#) and [BCR431U](#) drivers feature an extra-low voltage drop and a smart temperature controlling circuit.



Low-power LED driver ICs (5–65 mA)

Product type	Group	Topology	V_S (min) [V]	V_S (max) [V]	I_{out} (typ) [mA]	I_{out} (max) [mA]	Dimming	Package	P_{tot} (max) [mW]
BCR401U	LED drivers for low-power LEDs	Linear	$1.4 + V_{fLED}$	40	10	65	Digital	SC74	750
BCR401W	LED drivers for low-power LEDs	Linear	$1.2 + V_{fLED}$	18	10	60	Digital	SOT343	500
BCR402U	LED drivers for low-power LEDs	Linear	$1.4 + V_{fLED}$	40	20	65	Digital	SC74	750
BCR402W	LED drivers for low-power LEDs	Linear	$1.4 + V_{fLED}$	18	20	60	Digital	SOT343	500
BCR405U	LED drivers for low-power LEDs	Linear	$1.4 + V_{fLED}$	40	50	65	Digital	SC74	750
BCR431U	LED drivers for low-power LEDs	Linear	6	42	15	42	Digital	SOT23-6	600

Medium and high-power LED driver ICs (65–500 mA)

Product type	Group	Topology	V_S (min) [V]	V_S (max) [V]	I_{out} (typ) [mA]	I_{out} (max) [mA]	Dimming	Package	P_{tot} (max) [mW]
BCR430U	LED drivers for mid-power LEDs	Linear	6	42	50	100	Digital	SOT23-6	600
BCR320U	LED drivers for mid-power LEDs	Linear	$1.4 + V_{fLED}$	$24 + V_{fLED}$	250	300	No	SC74	1000
BCR321U	LED drivers for mid-power LEDs	Linear	$1.4 + V_{fLED}$	$24 + V_{fLED}$	250	300	Digital	SC74	1000
BCR420U	LED drivers for mid-power LEDs	Linear	$1.4 + V_{fLED}$	$40 + V_{fLED}$	150	200	No	SC74	1000
BCR421U	LED drivers for mid-power LEDs	Linear	$1.4 + V_{fLED}$	$40 + V_{fLED}$	150	200	Digital	SC74	1000
BCR450	LED controllers	Linear	3	27	70	ext. switch	Digital	SC74	500
TLE4309G	LED drivers for linear high-power LEDs	Linear	4.5	24	500	500	Digital	TO263	–

Very low-cost LED driver ICs

BCR401W/ BCR402W

Features

- › Up to 500 mW power dissipation in a small SOT343 package
- › Negative thermal coefficient reduces output current at higher temperatures
- › Automotive qualified according to AEC-Q101
- › Suitable for a wide variety of applications and power ranges
- › Output current adjustable by resistor up to 60 mA
- › High-side current control
- › PWM dimmable by external transistor

Benefits

- › Driving current always under control for homogeneous light output
- › Longer lifetime of the LEDs due to reduced output current at higher temperatures (negative thermal coefficient)
- › Easy paralleling of drivers to increase current
- › Stacking of LEDs in front of driver to increase input voltage
- › Contributes to longevity and reliability of LED system

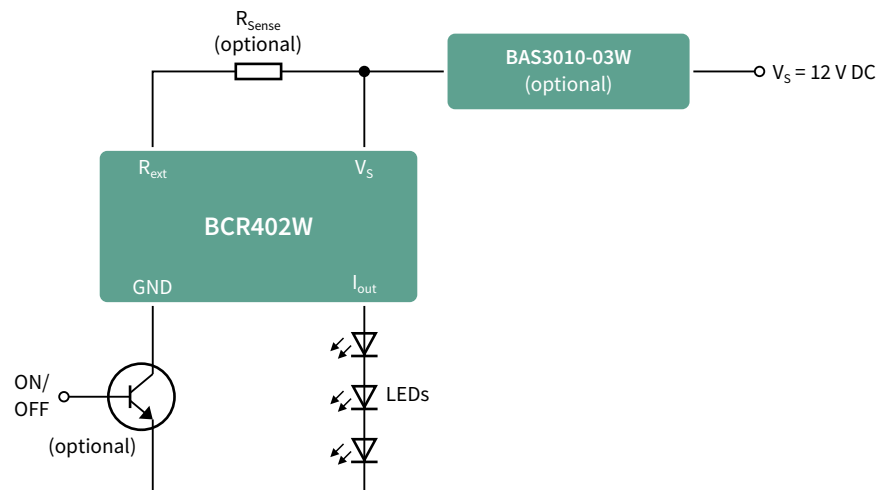

Application note

Name	Description
AN182	Comparison of resistor biasing versus BCR401W/BCR402W LED driver biasing of 12 V & 24 V DC low-current LED strip lights

Evaluation board

Name	Products	Description	Order number
BCR402W 12V LED BOARD	BCR402W BAS3010A-03W	12 V demoboard driving 3x 0.2 W LEDs in series	SP000748242
BCR402W 24V LED BOARD	BCR402W BAT64-02W	24 V demoboard driving 6x 0.2 W LEDs in series	SP000748244

Low-voltage-drop LED driver ICs

BCR430U/ BCR431U

Features

- > Max. 200 mV voltage drop at driver stage
- > Supply voltage from 6 to 42 V
- > Controls up to 100 mA LED current ([BCR430U](#))
- > Controls up to 42 mA LED current ([BCR431U](#))
- > Smart overtemperature protection

Benefits

- > Very low voltage drop allows use of more LEDs or longer strips overall, which means fewer feeding points.
- > Flexible current setting via resistor
- > Homogeneous light output
- > OTP: protecting not only the lifetime of the IC but also can be used to protect the reliability of the LED strip

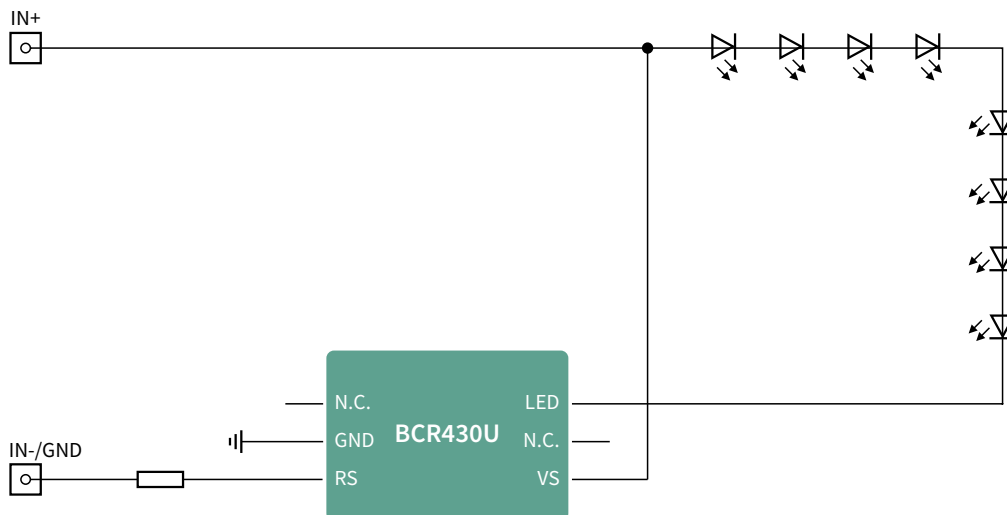

Application note

Name	Description
ER_201704_PL39_0	Engineering report linear LED driver IC BCR430U – features and performance for a 24 V/100 mA (max. LED current) solution, with explanations covering circuit and layout design for the demoboard
ER_2001_PL39_100719_BCR431U_2020-02-10	Engineering report linear LED driver IC BCR431U – features and performance for a 24 V/40 mA (max. LED current) solution, with explanations covering circuit and layout design for the demoboard
BCR431U Low voltage drop LED driver IC App Note	BCR431U – linear LED driver IC with low voltage drop – application note – operation, design guide and performance

Evaluation board

Name	Products	Description	Order number
BCR430U LED BOARD	BCR430U	Low-power demoboard with 8 LEDs, 50 mA	SP001709472
DEMO_BCR431U_LVDROP	BCR431U	Low-power demoboard with 8 LEDs, 15 mA	SP005351261

www.infineon.com/bcr430u

www.infineon.com/bcr431u

Robust LED driver ICs

BCR320U/BCR420U

Features

- > Homogeneous light output in different LED strings regardless of V_f and supply voltage
- > Easy to implement with a low component count
- > Flexibility to adjust the current via an external resistor from 10 mA up to 250 mA
- > Automotive qualified according to AEC-Q101

Benefits

- > Direct microcontroller interface for PWM dimming for [BCR421U](#) and [BCR321U](#) or dimming via PWM power of LEDs
- > Negative thermal coefficient to protect the lifetime of LEDs
- > High power dissipation capability

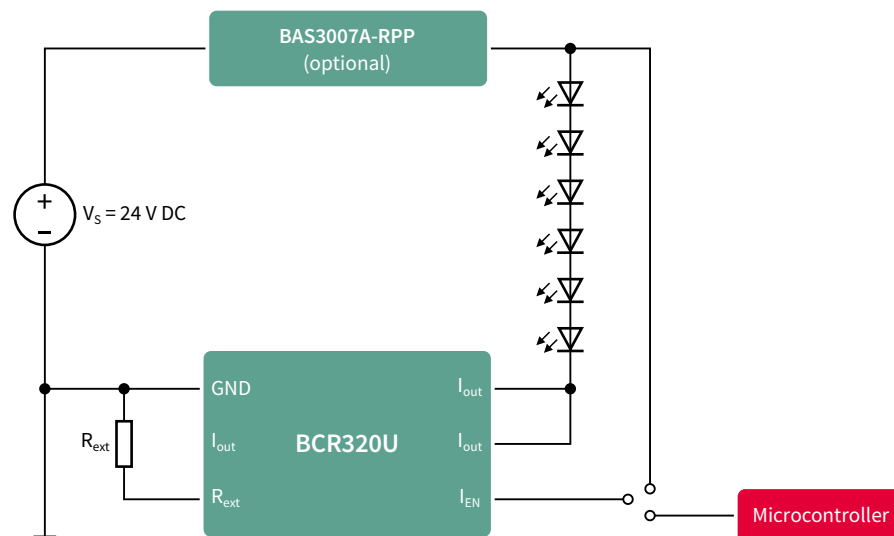

Infineon component list

Product type	Description
BCR320U/BCR321U/BCR420U/BCR421U	Medium-power LED driver
BAS3007A-RPP	Schottky bridge for reverse polarity protection (RPP)

Application note

Name	Description
AN212	Driving half-watt LEDs on a lightstrip with BCR320U , BCR321U or BCR420U , BCR421U

Evaluation board

Name	Products	Description	Order number
BCR320U HW LED BOARD	BCR320U BAS3007A-RPP	24 V BCR320U striplight demoboard driving 6x 0.5 W LEDs in series	SP000858442

BCR401U/BCR402U/BCR405U

Features

- › LED drive current preset to 10/20/50 mA
- › Output current adjustable by resistor up to 65 mA
- › Supply voltage up to 40 V
- › High-side current control
- › Up to 750 mW power dissipation in a small SC74 package
- › Negative thermal coefficient reduces output current at higher temperatures
- › Automotive qualified according to AEC-Q101

Benefits

- › Driving current always under control for homogeneous light output
- › Longer lifetime of the LEDs due to reduced output current at higher temperatures (negative thermal coefficient)
- › Easy paralleling of drivers to increase current
- › Contributes to longevity and reliability of LED system
- › High power dissipation capability

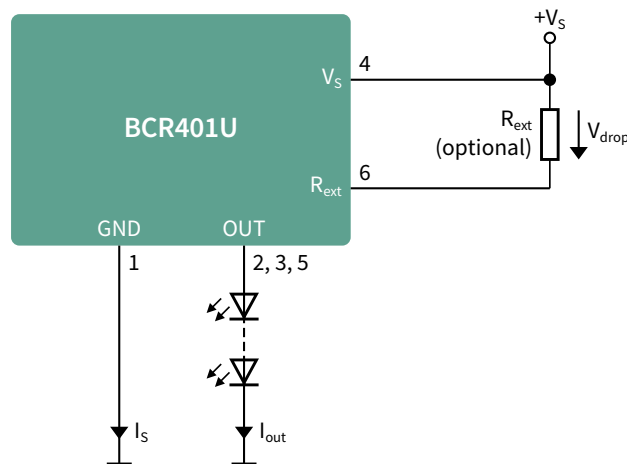
**Application note**

Name	Description
AN182	12 V and 24 V DC low-current LED striplights LED driver biasing using BCR401W/BCR402W vs. resistor biasing (AN182)
AN097	Using BCR402U at high supply voltages
AN101	LEDs from 10 mA to 700 mA driven by BCR4XX (AN101)
AN077	Thermal resistance calculation (AN077)

www.infineon.com/bcr401U

www.infineon.com/bcr402U

www.infineon.com/bcr405U

Radar sensors for presence detection and more

Passive infrared sensors – in short PIR sensors – are used in numerous lighting applications to save energy. PIR sensors detect the body heat radiated by people. While PIR sensors work well for some applications, certain weaknesses limit their suitability for other use cases. More specifically, these include the following:

- › Limited coverage
- › The opening required for the Fresnel lens complicates design and manufacturing of the lighting fixture
- › Poor sensitivity with regards to radial movements
- › No sensitivity with regards to micro movements when ambient temperature is similar to body temperature

Radar technology overcomes all of these challenges. Since the radar module can be integrated in the lighting fixture, there are no restrictions on the fixture design. In addition, the radar module enables platform solutions that can be used for different types of lighting fixtures. Radar is not temperature-dependent and also works under difficult weather conditions, including fog and rain. The high sensitivity of radar makes it suited to vital sensing applications including the detection of breathing and heart rate.

Furthermore, radar enables new functions like the detection of direction, position and speed. It can also track and count people. All of this extended functionality is enabling new use cases like identifying the usage of meeting rooms and taking the necessary actions for better use of the real estate.

Looking at the many advantages of radar technology, one might wonder why it is not widely used in lighting. In fact, radar has now started to penetrate lighting applications, but a large number of luminaire makers are simply not yet aware of the benefits of this technology. Furthermore, there are some misconceptions around pricing and ease of implementation. Radar solutions may have been expensive in the past, but large-volume deployment in the automotive industry in particular has brought this technology to a more mature, affordable space. Our radar partners already offer a portfolio of certified radar modules to ensure ease of implementation. Given the lively interest in radar solutions among lighting customers, it is likely that this portfolio of radar modules will be expanded further. On the following pages, you will find examples of radar modules offered by some of our radar partners.



Radar partner ecosystem at a glance including design house partners

EMEA		
Greenwaves		
24/60/77 GHz	DH	I
InnoSenT		
24/60/77 GHz	M + DH	I/A
NovellC		
24/60/77 GHz	DH	I/A
RFbeam		
24/60/77 GHz	M + DH	I/A

Greater China		
Cheng Tech		
24 GHz	DH	I
Entros		
24 GHz	M + DH	I/A
Honmax		
24 GHz	DH	I
KingCity		
24/60 GHz	DH	I
Nanoradar		
24 GHz	M + DH	I/A
Sensortech		
24 GHz	M + DH	I/A
RichGreenTek		
24 GHz	DH	A
TransMicrowave		
24 GHz	DH	I/A

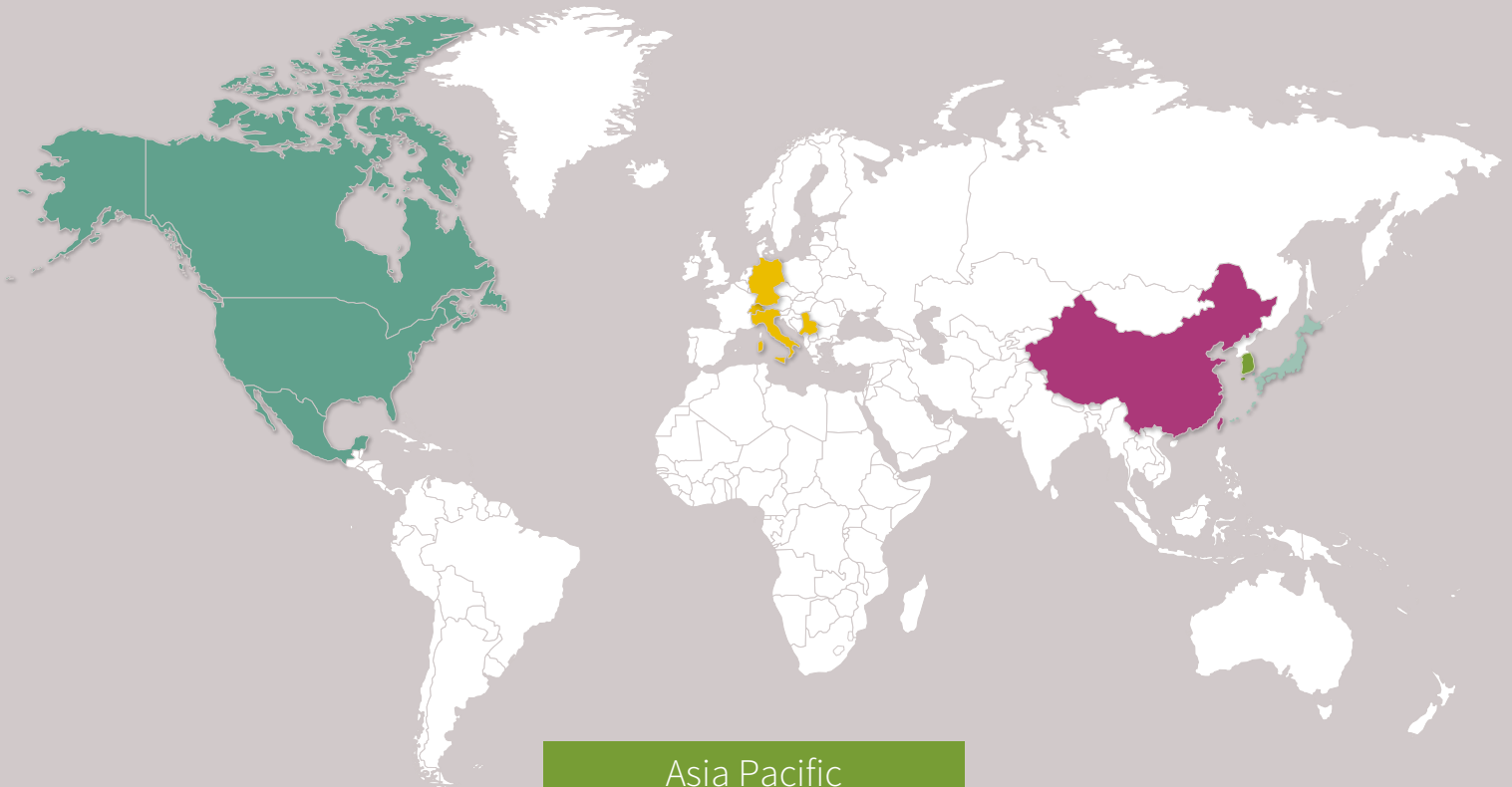

Americas		
Ancortek		
24 GHz	M + DH	I
Colorado Engineering		
24/60/77 GHz	M	I/A
Delta Mobile Systems		
24 GHz	M + DH	I/A
OmniPreSense		
24 GHz	M + DH	I

Asia Pacific		
Bitsensing Inc.		
24/60 GHz	DH	I
Digitaledge Inc.		
24/60 GHz	DH	I
Inzinious		
24 GHz	DH	I/A
M-Clavis		
24/60/77 GHz	M + DH	I
Newest one		
24 GHz	M + DH	I
Wooriro		
24 GHz	M + DH	I

Japan		
PTM		
24/60 GHz	DH	I
Sharp Takaya		
24 GHz	DH	I/A

Abbreviations: M = "Off-the-shelf" radar module provider DH = Design house/customized modules I = Industrial and consumer applications A = Automotive applications

Our partners

Our system design house partners deliver both standard products and customized solutions to fit specific lighting applications from movement detection through automatic light activation to person counting. In addition, they offer all levels of support to get your intelligent lighting system up and running as quickly and efficiently as possible. On the next pages you can gain an overview of some standard products.

K-LDx series from RF-Beam Radar module

RFbeam

RFbeam Microwave GmbH is a leading supplier of planar Radar sensors, K-band measuring equipment and engineering. Their product range covers simple low cost Doppler devices as well as state-of-the-art digital and superhet transceivers and systems. Typical applications are movement and industrial sensors, traffic supervision and analyzer systems, sport measurement equipment and many other uses.

K-LD2 certified radar module

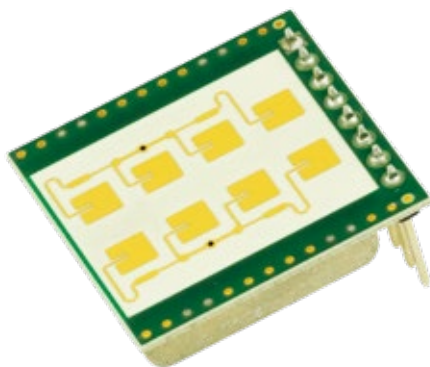

K-LD2 certified radar module

- › Presence detection including slight movements
- › Detection distance up to 15 m (humans) 30 m (cars)
- › Can be hidden in the luminaire
- › Small footprint of 25 x 25 x 6.5 mm
- › 80°/34° beam aperture
- › Sensitivity for micro movements can be adjusted
- › Wide power supply range from 3.2 to 5.5 V
- › Fully certified plug & play solution
- › Very cost-effective solution

K-LD7 certified radar module

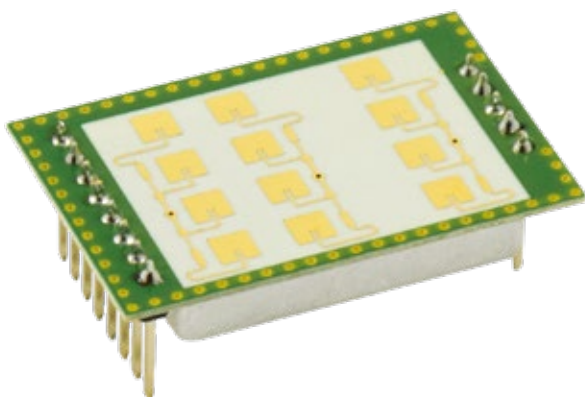

Features

- › Presence detection including slight movements
- › Add-on features like measurement of
 - Distance
 - Direction
 - Angle
- › Detection distance up to 15 m (humans) 30 m (cars)
- › Can be hidden in the luminaire
- › Small footprint of 37 x 25 x 7 mm
- › 80°/34° beam aperture
- › Sensitivity for micro movements can be adjusted
- › Wide power supply range from 3.2 to 5.5 V
- › Fully certified plug & play solution

INS-Series from InnoSenT: Motion and presence detector in one radar system



InnoSenT GmbH from Donnersdorf was founded in 1999 and is one of the world's leading companies in the field of radar technology. As a manufacturer and developer, the company supplies the full bandwidth of engineering services - from customer-specific development to series production. Thanks to the strong focus on quality and innovation, InnoSenT GmbH has been following a course to global success for many years.

INS-313X

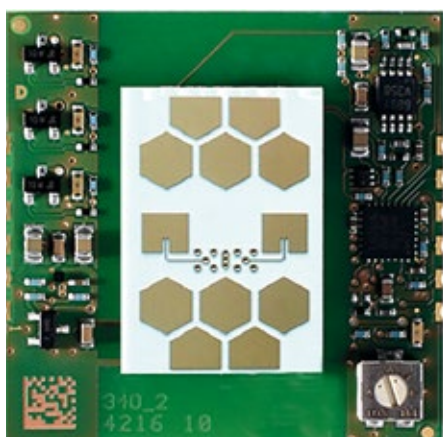

Features

- > Can be concealed behind many materials
- > Motion detection range of up to 5 m for humans
- > Detection range adjustable via potentiometer (only for advanced version INS-3130)
- > Proximity switch for object detection (distances of less than 5 cm)
- > Movement recognition with direction, velocity and signal strength over range from 1.5 to 5 m
- > Advanced version INS-3130 comes with open collector outputs
- > UART interface
- > ECO and standby mode for reduced power consumption
- > Delivered on tape and reel
- > Flat SMD design with 5 mm height

INS-333x

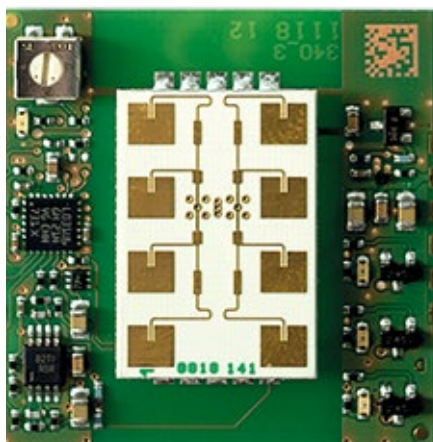

Features

- > Can be concealed behind many materials
- > Motion detection range of up to 10 m for humans
- > Detection range adjustable via potentiometer (only for advanced version INS-3330)
- > Proximity switch for object detection (distances of less than 10 cm)
- > Movement recognition with direction, velocity and signal strength over range from 2 to 10 m
- > Open collector outputs (only for advanced version INS-3330)
- > UART interface
- > ECO and standby mode for reduced power consumption
- > Delivered on tape and reel
- > Flat SMD design with 5 mm height

Radar Motion and Presence Sensor



NOVELIC is a high-tech B2B engineering, design services, and solutions company. The company provides design services for analog, AMS, digital, and RF IC design, ASIC & FPGA, embedded systems, sensor fusion, DSP, MEMS, mechanical system, sensors & multimedia signal processing, 802.11 communications, and mm-wave Radar sensor modules. The NOVELIC team has multidisciplinary in-house knowledge, allowing the company to deliver solutions for systems, hardware, software, and algorithms for various automotive, consumer, industrial, healthcare, transportation, and safety applications.

RIOT100 advantages

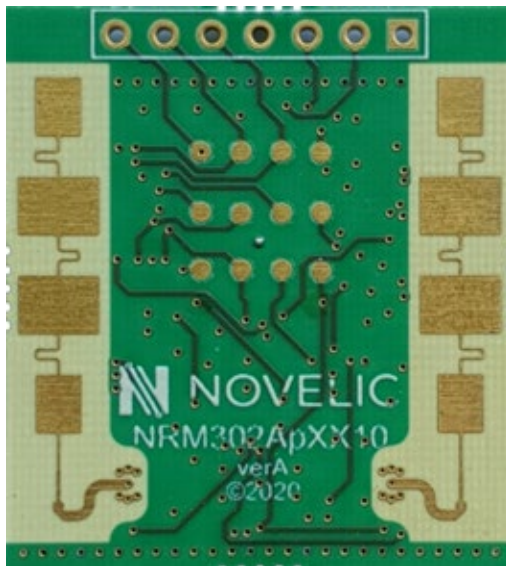

Features

- › Turnkey motion and presence sensor solution
- › No radar signal processing knowledge required
- › Distance teaching function for user-friendly detection area adjustment
- › Completely invisible integration
- › No lenses or cut-outs required
- › Completely independent of:
 - ambient and object temperature
 - light conditions
 - environment conditions
- › Ideal for high-temperature operation in luminaires
- › Anonymous detection without privacy invasion
- › License-free operation
- › Cost effective solution

Features

- › Detects humans' motion up to 15 m
- › High sensitivity presence detection mode
- › 120° field of view
- › 3.3V supply and interfaces
- › Low power consumption
- › Compact dimensions 30mm x 27mm x 6mm
- › Determines the direction of movement and object distance
- › Detects multiple objects simultaneously
- › Integrated radar signal processor
- › Digital object list data output
- › UART and I²C interface
- › Event trigger interrupts

Wireless networking enabling automation, efficiency, occupancy interaction, and safety

Bluetooth's many advantages have given rise to its now ubiquitous presence. The Bluetooth standards are maintained and advanced by the Bluetooth Special Interest Group (SIG), which as of this writing has some 33,000 members in 150 countries.

The advent of Bluetooth Mesh networking has expanded the scale and scope for lighting applications. With support for over 30,000 network nodes, Bluetooth Mesh can handle applications that span large buildings, healthcare enterprises and campuses.

A Bluetooth Mesh network topology enjoys two significant advantages: virtually unlimited scalability and high resiliency, both of which have contributed to the protocol's popularity among product design engineers. These advantages derive from the many-to-many communications that form multiple paths throughout the network from source-to-destination, as shown in Figure below.

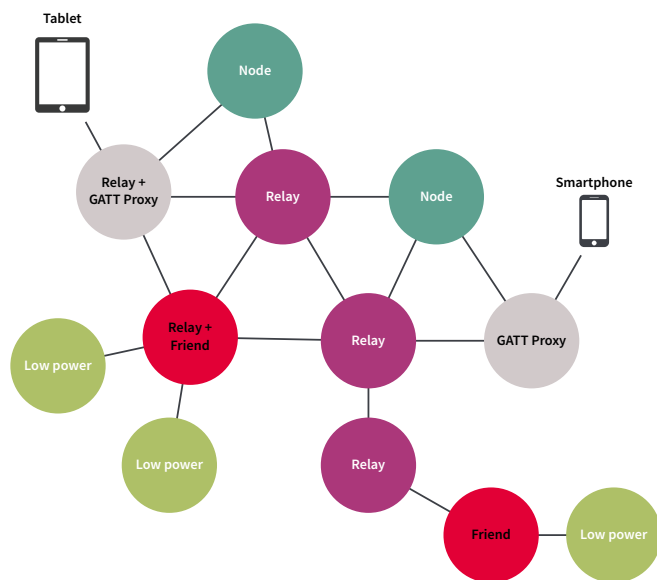

The m:m connections assure successful communications even when multiple nodes have failed or been taken out of service, whether temporarily or permanently. Putting it another way: Bluetooth Mesh networks can expand far and wide with no single points of failure.

For connectivity to enterprise and cloud applications where the Bluetooth Mesh network may need to communicate with a Wi-Fi network, a gateway functionality will be needed. For example, an enterprise efficiency and security system could be used to turn on or off certain lights relative to occupancy patterns or sensor notifications. In these situations, a host SoC combo-module that supports both Wi-Fi and Bluetooth LE networking simplifies the design effort gracefully managing wireless coexistence and the bridging of Bluetooth Mesh communications with the enterprise network.

Bluetooth LE protocol ubiquity also gives Bluetooth another important advantage: the availability of proven techniques, tools and software needed to develop new products. Hardware and software engineers interested in learning more about these resources are encouraged to review the documents and links listed in the references below.

The many resources now available make it easy to get started with Bluetooth Mesh. Proof-of-concept designs can be created quickly and affordably using inexpensive evaluation boards, IDEs and SDKs.

Offering device, smartphone, tablet and gateway interoperability and power efficient, cost effective connectivity, Bluetooth Mesh is destined to become the network of choice for a growing number of residential, commercial and industrial lighting applications.

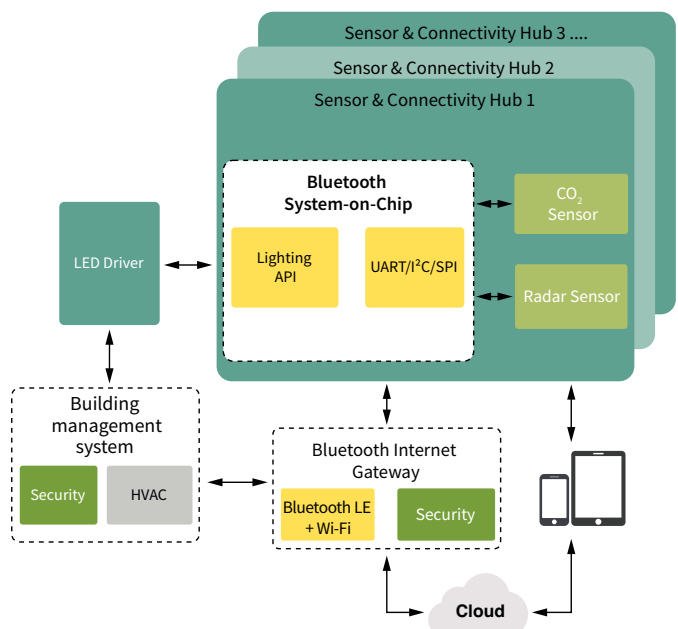

Bluetooth Mesh devices and modules

Embedding Bluetooth Mesh networking in lighting systems including luminaires, fixtures, and wall switches opens a range of system applications to manage lighting brightness or color, efficiency based on occupancy movements and correlation of lighting ecosystem components. The range and coverage of Bluetooth Mesh devices allows for low latency, whole building coverage of automation and occupancy interaction via smartphone and tablet applications as well as cloud applications for building management. Infineon provides a range of Bluetooth Mesh MCUs and certified modules that enable lighting control functionality, safety and occupancy sensor management and robust, secure, reliable networked managed solutions.

Bluetooth Mesh SoCs and certified modules: solutions and benefits

Bluetooth Mesh system-on-a-chip (SoCs) and certified modules offer a range of efficient and future-proofed upgradeable solutions:

Solutions	Benefits
Module diversity with integrated components ranging from the basic battery-powered sensor to the most sophisticated detection and safety devices	Accommodating different needs now and in future
Fully-integrated modules	<ul style="list-style-type: none"> › Accelerate time-to-market › Reducing development and manufacturing costs
Ultra-high-transmit power designs with integrated antennas	Enabling long range and unfailing node-node connections
Integrated CPU, memory (flash and RAM) and I/O	Suiting all foreseeable applications hosting

Bluetooth Mesh evaluation kit **CYBT-213043-MESH**

The Bluetooth Mesh evaluation kit (**CYBT-213043-MESH**) enables you to evaluate SIG Mesh functionality and features using the **CYBT-213043-02 module**. The **CYBT-213043-02 module** is an integrated, fully certified, 12.0 mm x 16.61 mm x 1.70 mm, programmable Bluetooth® Smart Ready module designed to reduce your time-to-market.

Utilized device: **CYW20819**

Kit contents:

- › 4x mesh evaluation boards
- › 4x USB A to micro-B cables
- › 1x quick-start guide (this document)

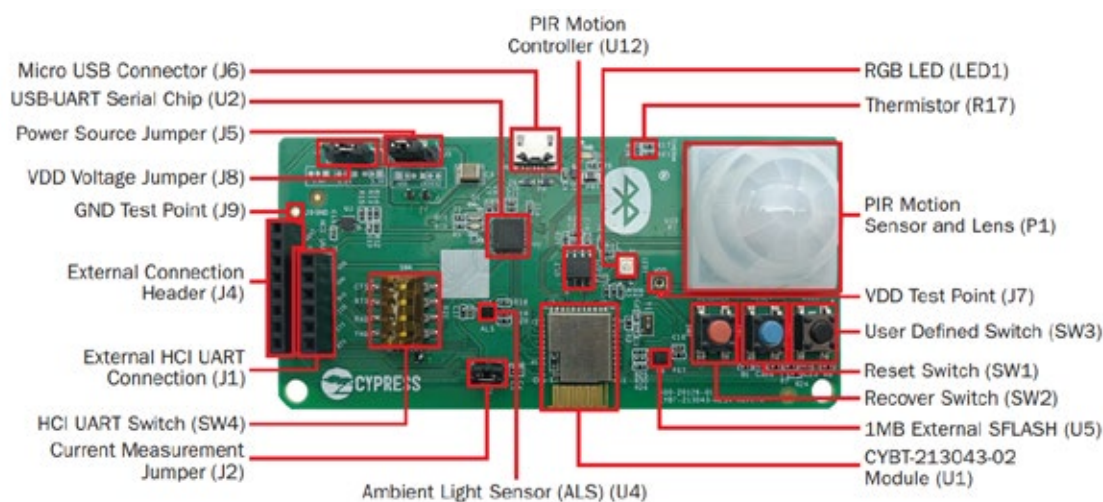





Bluetooth Mesh Networking - An Introduction for Developers
[Bluetooth-Mesh-Paving-the-Way-for-Smart-Lighting](#)
 Bluetooth-Mesh specifications:
www.bluetooth.com/specifications/mesh-specifications



Getting Started with
 Bluetooth Mesh
 (AppNote AN227069)

Selection of Bluetooth Mesh devices and modules for connected and smart lighting applications









Mesh-enabled, silicon, dual-mode Bluetooth 5.0 MCUs

	CYW20706	CYW20735	CYW20819	CYW20820	CYW20719
Product features					
TBA Processor	CM3	CM4 w/ FPU	CM4	CM4	CM4 w/ FPU
TBA Radio	-	ULP RF	ULP RF	ULP RF	ULP RF
Operating temperature	105 C	85 C	125 C planned	125 C planned	85 C
Transmit power	10 dBm Tx	10 dBm Tx	4 dBm Tx	10 dBm Tx	4 dBm Tx
Memory	-	-	256 kB Flash	256 kB Flash	1 MB Flash



Interested in more? We offer a broad silicon portfolio to support your Bluetooth Mesh design. [Explore here.](#)

Fully-certified Bluetooth modules (FCC, ISED, MIC, CE)



	<p>Load range Up to 20 dBm transmit power</p>  <p>CYBT-483056-02</p>	<p>Size and simplicity Ez Serial support enables fast time to market and 9x9 size for small form factor application</p>  <p>CYBT-353027-02</p>	
	<p>Value Balance of features for cost sensitive applications</p>  <p>CYBT-343052-02</p>	<p>Integration Fully integrated SoC with lowest power and extended range</p>  <p>CYBT-273063-02</p>	

Wi-Fi enterprise networking and internet connectivity

Wi-Fi networking is the back-bone of enterprise, retail, and home internet connectivity. Wi-Fi is the bridging medium for Bluetooth Mesh networks to enterprise networks and cloud applications capturing messaging from across the lighting installation for secure enterprise building management applications.

Wi-Fi can also be used to connect sensors and fixtures directly to enterprise or home access points for long range solutions or integrated solutions including security lighting and cameras. Infineon offers a range of secure, high performance enterprise ready Wi-Fi solutions that can be added to switches, panels, and lighting bays. These solutions can be stand-alone network nodes or offer Bluetooth Mesh Gateway services bridging Mesh-networked devices to cloud applications.

IoT Wi-Fi portfolio

Technology	Wi-Fi	Wi-Fi + MCU	Wi-Fi + Bluetooth combos
Wi-Fi 4 (802.11n)	CYW43364 SB 1x1 11n SDIO 	CYW43903 SB 1x1 11n + 160-MHz R4 CYW43907 1x1 DB 11n + 320-MHz R4	CYW43439* SB 1x1 11n + BT5.2 SDIO/SPI CYW43012 ULP DB 1x1 11n + BT5.1 SDIO/SPI WLPGA/WLCSP 
	Wi-Fi 5 (802.11ac)		CYW54907 1x1ac DB + 320-MHz R4 
			CYW54591 DB 2x2 11ac, RSDB, BT5.1 PCIe/SDIO



Infineon's Wi-Fi portfolio provides high-performance, flexible connectivity for Linux, Android, and RTOS. Many of the Wi-Fi + Bluetooth combos are supported on Infineon's WICED Wi-Fi and ModusToolbox Software Development Kits (SDK) which provide code examples, tools and development support.

Infineon's Wi-Fi and Bluetooth combos use production-ready, fully-certified Wi-Fi + Bluetooth combo modules based on both Linux and RTOS based platforms. Many of the Wi-Fi + Bluetooth combos are supported on Infineon's WICED Wi-Fi and ModusToolbox Software Development Kits (SDK) which provide code examples, tools and development support for **easier and faster development.**

*Coming soon

**For more information on this product, contact our [product support](#).

Wi-Fi enterprise networking and internet connectivity

		
CYW43907: MCU + Wi-Fi	PSoC or 3rd party MCU: PSoC or 3rd-party MCU running RTOS 3rd-party SoC running Linux OS	P/N: CY8CKIT-06S2-43012 PSoC 6: Ultralow-power dual-core MCU
CYW20719: Dedicated Bluetooth 5.1 MCU	CYW43439*: 1x1n Wi-Fi + Bluetooth combo SoC	CYW43012 (Murata Type 1LV): Dedicated low-power Wi-Fi + Bluetooth 5 combo SoC

We offer a broad platform portfolio to support your Bluetooth Mesh gateway. [Explore more here.](#)

IoT Wi-Fi portfolio

A global Wi-Fi module partner ecosystem enables support and development for your IoT application.

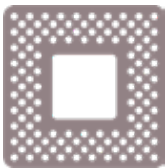

Design, build and sell RF Modules with limited software and hardware certification support

Module makers



*Coming soon

OPTIGA™ Trust M

Turnkey security solution optimized for connected devices

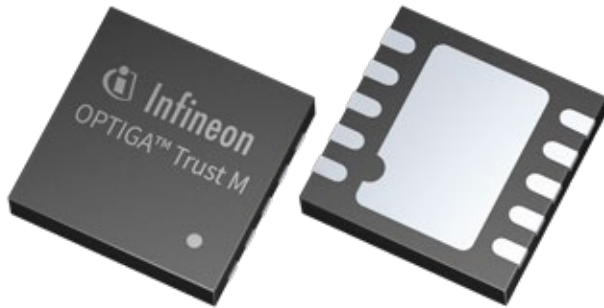

The OPTIGA™ Trust M is a high-end security solution that provides an anchor of trust for connected IoT devices, giving every IoT device its own unique identity. OPTIGA™ Trust M offers a wide range of security features, making it ideal for industrial and building automation applications, smart homes and connected consumer devices.

The turnkey setup with full system integration minimizes design, integration, and deployment effort.

Features

- › CC EAL6+ (high) certified controller
- › Up to 10kB user memory
- › 2C interface with Shielded Connection
- › Cryptographic support:
 - ECC: NIST curves up to P-521, Brainpool r1 curve upto 512
 - RSA® up to 2048
 - AES key up to 256 , HMAC up to SHA512
 - TLS v1.2 PRF and HKDF up to SHA512
- › Crypto ToolBox commands for SHA-256, ECC and RSA® Feature, AES, HMAC and Key derivation
- › OPTIGA™ Trust M Software Framework on Github
- › Configurable device security monitor, 4 Monotonic up counters
- › Protected update of data, key and metadata objects
- › Hibernate for zero power consumption
- › Temperature: -25°C to 85°C and -40 to 105°C
- › Lifetime of up to 20 years for industrial automation and infrastructure

Benefits

- › **Secured zero-touch provisioning:** secured, fast, and easy access to any major cloud service provider thanks to pre-provisioned certificates
- › **Easy integration:** turnkey set-up with full system integration, reference designs, application notes and a wide range of use cases to minimizes your design, integration and deployment effort
- › **Future-proof security:** OPTIGA™ Trust M provides a toolbox supporting the most advanced cryptographic schemes to help customers withstand todays and future security challenges
- › **MIT licensed software:** the open source framework allows customers to benefit from direct support from developers as well as from regular updates on new versions and features

Where to buy

Infiniteon distribution partners and sales offices:

www.infineon.com/WhereToBuy

Service hotline

Infiniteon offers its toll-free 0800/4001 service hotline as one central number, available 24/7 in English, Mandarin and German.

- > Germany 0800 951 951 951 (German/English)
- > China, mainland 4001 200 951 (Mandarin/English)
- > India 1 800 572 4924 (English)
- > USA 1-866 951 9519 (English/German)
- > Other countries 00* 800 951 951 951 (English/German)
- > Direct access +49 89 234-0 (interconnection fee, German/English)

*Please note: Some countries may require you to dial a code other than "00" to access this international number.
Please visit www.infineon.com/service for your country!

www.infineon.com

Published by
Infineon Technologies Austria AG
9500 Villach, Austria

© 2022 Infineon Technologies AG.
All Rights Reserved.

Please note!

This Document is for information purposes only and any information given herein shall in no event be regarded as a warranty, guarantee or description of any functionality, conditions and/or quality of our products or any suitability for a particular purpose. With regard to the technical specifications of our products, we kindly ask you to refer to the relevant product data sheets provided by us. Our customers and their technical departments are required to evaluate the suitability of our products for the intended application.

We reserve the right to change this document and/or the information given herein at any time.

Additional information

For further information on technologies, our products, the application of our products, delivery terms and conditions and/or prices, please contact your nearest Infineon Technologies office (www.infineon.com).

Warnings

Due to technical requirements, our products may contain dangerous substances. For information on the types in question, please contact your nearest Infineon Technologies office.

Except as otherwise explicitly approved by us in a written document signed by authorized representatives of Infineon Technologies, our products may not be used in any life-endangering applications, including but not limited to medical, nuclear, military, life-critical or any other applications where a failure of the product or any consequences of the use thereof can result in personal injury.